

ASSEMBLY INSTRUCTION

ROUND EDGE BAR CART WITH MIRROR BOTTOM AND TOP

A Side Panel  2pcs	B Handle  1pc	C Front Frame  2pcs	D Back Frame  1pc
E Small Mirror  1pc	F Large Mirror  1pc	G Caster Wheel 40mm  4pcs	H Bolt 1/4" x 1/2"  16pcs
I Plastic Tube 6 x 25mm  8pcs	J Allen Wrench 1/4"  1pc	K Open Wrench 13mm  1pc	

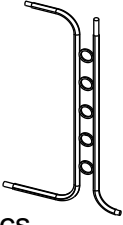
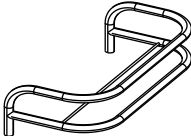
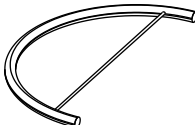
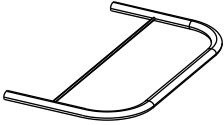
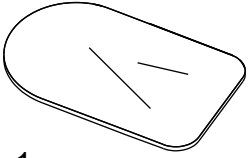
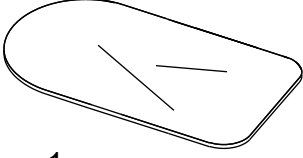
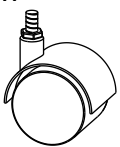
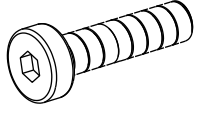
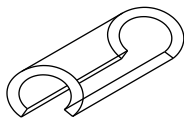
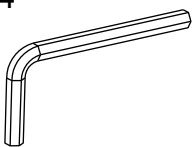
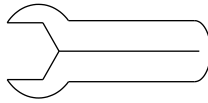
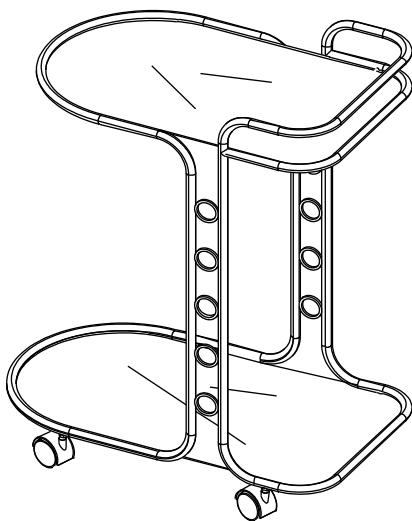

This page lists all the contents included in the box. Please take the time to identify the hardware as well as the individual components to this product. As you unpack and prepare for assembly, place the contents on a carpeted or padded area to protect them from damage.

***** Do not tighten screws & bolts until the entire unit is completely assembled.**

1 Attach Handle (B), Front Frame (C) and Back Frame (D) to Side Panel (A) by Bolt (H) and Allen Wrench (J) as shown.

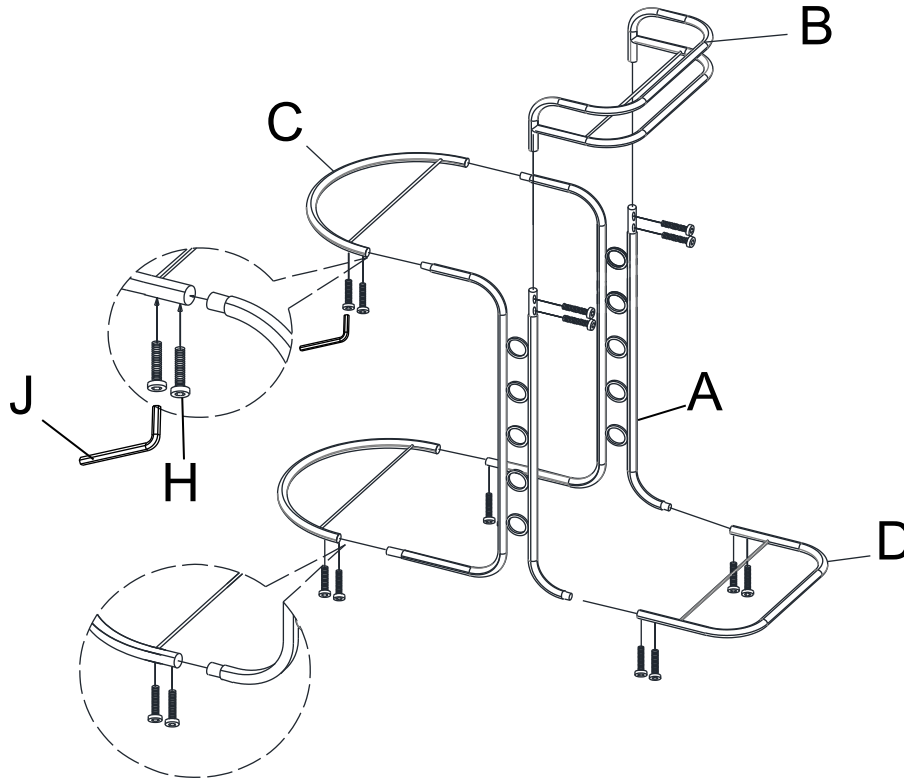

2 Attach Caster Wheel (G) to the bottom of Front Frame (C) and Back Frame (D) by Open Wrench (K). Then attach Plastic Tube (I) to Handle (B), Front Frame (C) and Back Frame (D) as shown.

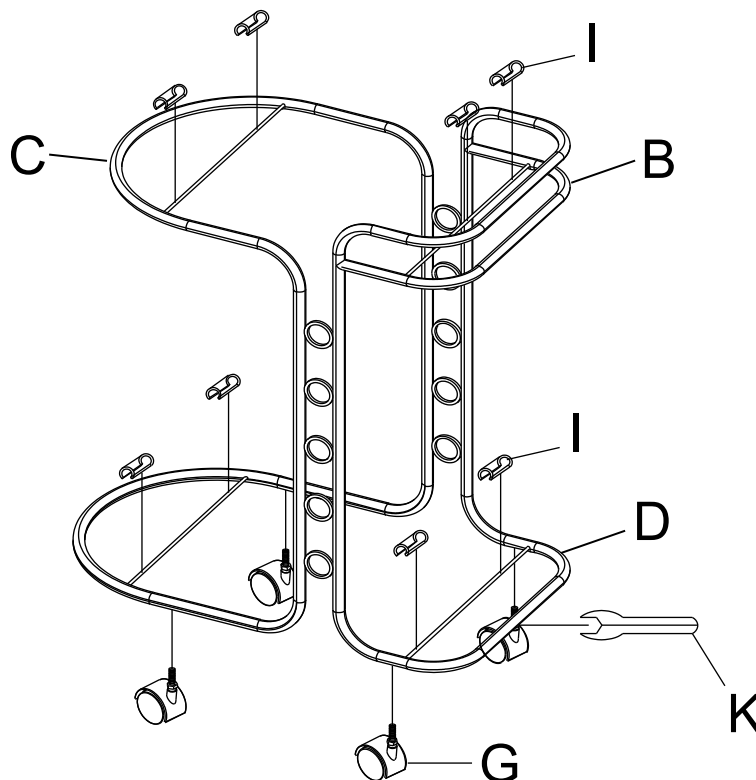

3

Place Mirror (E) and (F) to the bar cart as shown.

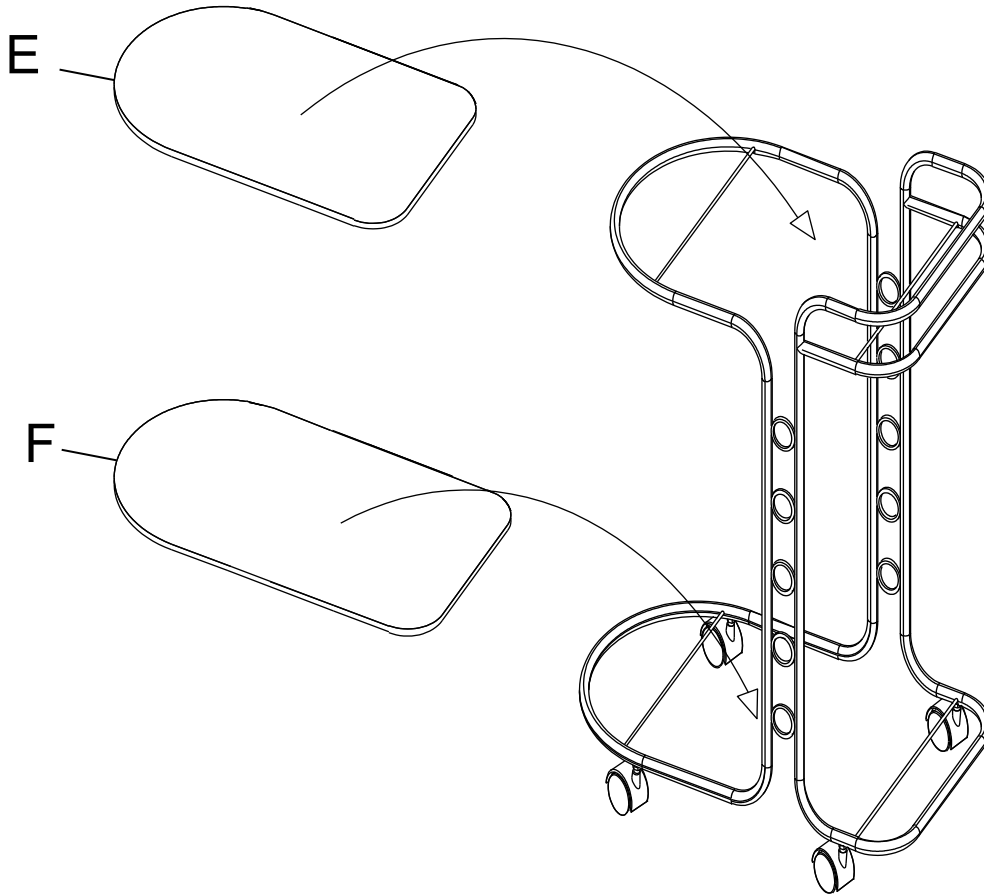

Cleaning & Care

Treat surface with care. Surface is resistant to scratches but is not scratch resistant. Clean surfaces with a dry or damp soft cloth. Do not use abrasive cleaners. Hardware may loosen over time. Periodically check that all connections are tight.