

# Plastic Drum

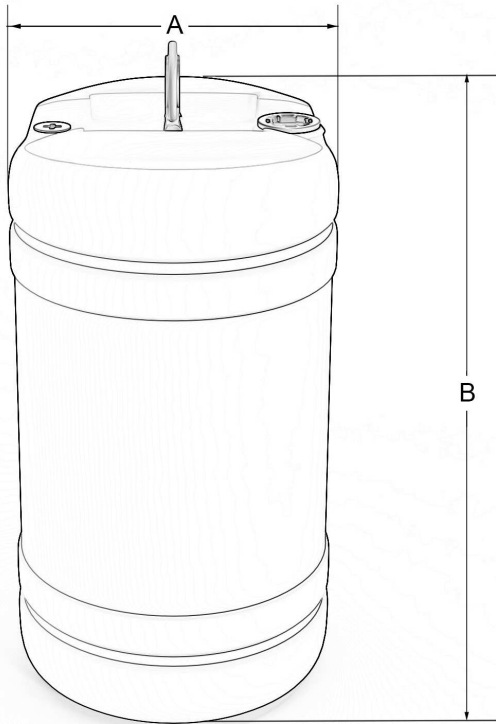

## Specifications

UN Mark(s)	1H1/Y1.9/150
Nominal Capacity	15 gal
Nominal O.D. (A)	14.5 inches
Overall Height (B)	26.1 inches
Mid Panel Height	15.6 inches
Total Weight	7.5 lbs
Body Weight	6.8 lbs
Min. Wall Thickness	0.090 inches

Body Construction	Extrusion blow molded
Handle(s)	1 Plastic handle, hinged
Resin Type	HDPE / GB1 Resin
Drum Color	Neutral
Plug #1	G2X11.5 NPS PLASTIPLUG™ EPDM
Plug #2	G3/4X14 NPS PLASTIPLUG™ PP Natural with EPDM Gasket
Special Instructions	None
Design Notes	Recycle symbol embossed on bottom.
Filling Temperature	Maximum filling temperature 160°F. When filled at this maximum temperature, drums should be allowed to cool to ambient prior to stacking. Drums filled at elevated temperatures should be vented properly to prevent vacuum formation within the drum which can compromise stacking capability.

DISTRIBUTED BY:



REF NO.:

DWG31821

DESCRIPTION:

15 Gallon HDPE TH Drum with 2" Buttress & 3/4" NPS Fittings

### DISCLAIMER

THIS INFORMATION IS PROVIDED AS A GENERAL GUIDE, INCLUDING DIMENSIONS. IT IS THE CUSTOMER'S RESPONSIBILITY TO SELECT THE PROPER CONTAINER FOR PRODUCT AND APPLICATION COMPATIBILITY.