

20.0 Liter Rectangular Tight Head with Swing Handle

Product Uses

Liquid Products

Product Codes

Container: **RTH Series**

Description: 20L Rectangular Tighthead

Features

UN Rating: 3H1/Y1.8/100
 Nominal capacity: 5.3 USG / 20.0L
 Maximum capacity: 5.8 USG / 22.0 L
 Tare weights: 2.74 lbs / 1.24 kgs

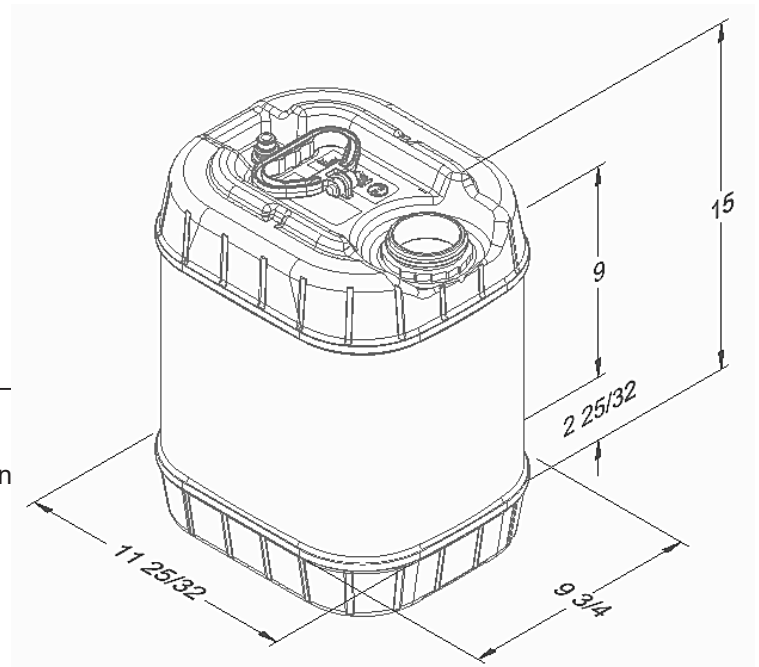

Colors

Standard: White, Black, Blue and Natural
 Custom: Available at manufacturer's discretion

Decorating Options

Maximum Label Area:
 Perimeter: 38-1/4" x 8-3/4" H
 See Salesperson for Options

Shipping Data

Qty. per floor spot: 112
 Gross Weight (lbs./kgs)*: 268 / 121
 Length (in./cm.): 48 / 122
 Width (in./cm.): 35.3 / 90
 Height (in./cm.): 108.5 / 275.6

Containers

Estimated truckload quantity of 3,360 containers**

Notes: *Weight does not include pallet / packaging
 **Truckload quantity based on 53' trailer

Materials

FDA approved materials
 Resin: Body: High-Density Polyethylene (HDPE)
 Handle/Pin: High-Density Polyethylene (HDPE)

Optional Carrying Handle

Swing Handle with Pin

DISTRIBUTED BY:



REF NO.:

DWG31106

DESCRIPTION:

20 Liter HDPE Square Tight Head Pail, 70 mm, 6 TPI with Swing Handle

DISCLAIMER

THIS INFORMATION IS PROVIDED AS A GENERAL GUIDE, INCLUDING DIMENSIONS. IT IS THE CUSTOMER'S RESPONSIBILITIES TO SELECT THE PROPER CONTAINER FOR PRODUCT AND APPLICATION COMPATIBILITY.