



Manufactured by:
Backyard Discovery
3305 Airport Drive, Pittsburg, KS 66762
800-856-4445

Basepoint Business Centre: Rivermead Drive, Westlea, Swindon SN5 7EX Phone: 0800-118-2476
J.P. Coenstraat 7, The Bridge, The Hague, 2595 WP, Netherlands Phone: 08005678990

ACACIA POTTING TABLE

MODEL # : 2107038



Please visit www.backyarddiscovery.com
For the most up to date assembly manual, to register your product, or to order
replacement parts *Para obtener instrucciones en español, visite*
www.backyarddiscovery.com



**INSTALLATION
SERVICES
AVAILABLE!**
See inside for details

OWNER'S MANUAL - BASIC SETUP DIMENSIONS & ASSEMBLY NOTES

It is critically important that you start with square and level footings, concrete pad or deck to attach your structure

- Pay close attention to the items needed for each step. Make sure you are using the correct hardware for each step. Using incorrect hardware may result in improper assembly

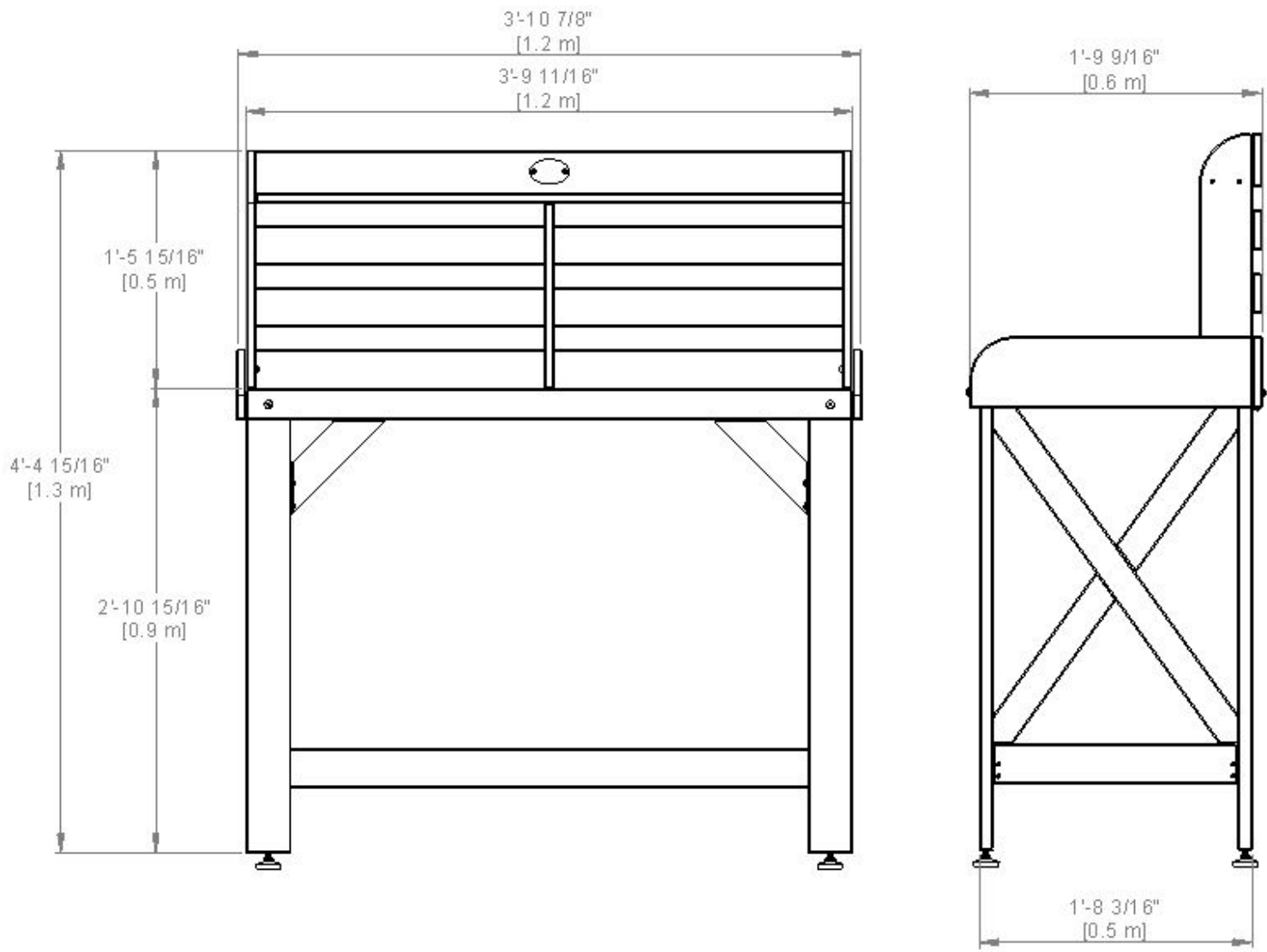

OWNER'S MANUAL - PARTS IDENTIFICATION

Wood Components (Not to Scale)

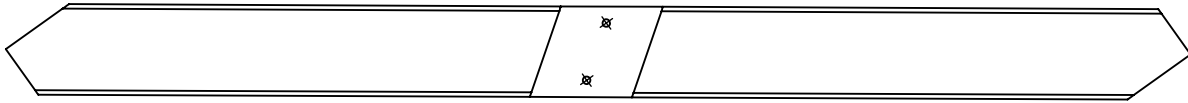

CB2 | CROSS BRACE-W4L15972
(x2) | 1 1/16"x2 3/8"x30 7/8" (27x60x784)

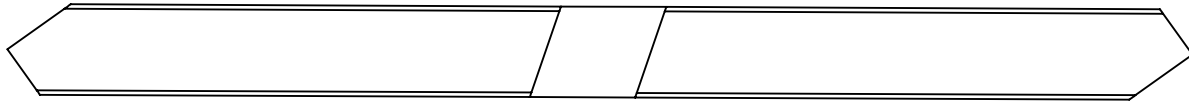

CB1 | CROSS BRACE-W4L15973
(x2) | 1 1/16"x2 3/8"x30 7/8" (27x60x784)

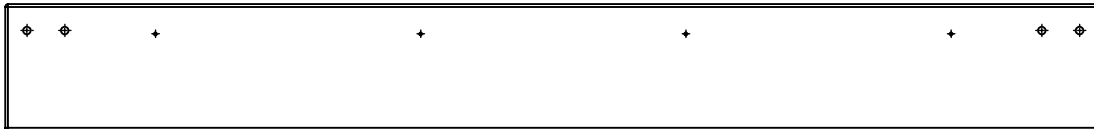

BP3 | BACK PANEL BOARD-W4L15967
(x1) | 11/16"x5 1/4"x45 11/16" (18x134x1160)

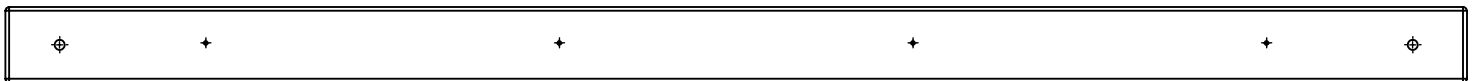

FB1 | FRONT BRACE-W4L15970
(x1) | 11/16"x2 3/8"x45 11/16" (18x60x1160)

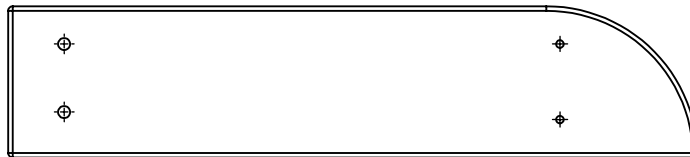

BP7 | BACK SHELF UPRIGHT-W4L15965
(x2) | 11/16"x3 15/16"x17 15/16" (18x100x456)



BP5 | BACKING BOARD-W4L15969
(x1) | 11/16"x3 15/16"x45 11/16" (18x100x1160)

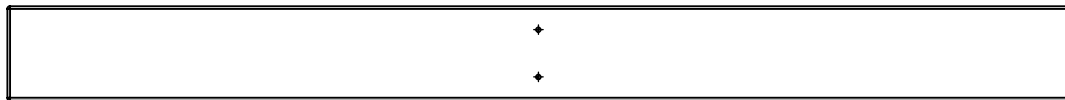

BP4 | TOP SHELF BOARD-W4L15968
(x1) | 11/16"x3 15/16"x44 1/4" (18x100x1124)



BP2 | BACK SHELF MIDDLE UPRIGHT -W4L15966
(x1) | 11/16"x3 15/16"x14" (18x100x356)



BP6 | BACK BOARD-W4L16230
(x2) | 11/16"x3"x45 11/16" (18x76x1160)

OWNER'S MANUAL - PARTS IDENTIFICATION

Wood Components (Not to Scale)

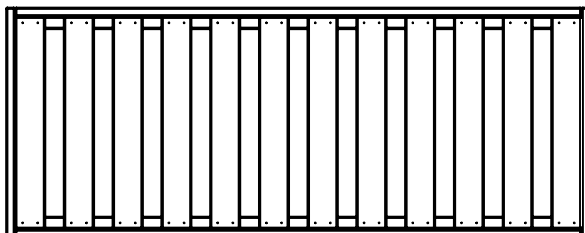

BP1 | BOTTOM PANEL ASSEMBLY-W2A03363
(x1) | 3"x18 1/16"x45 11/16" (76x458x1160)

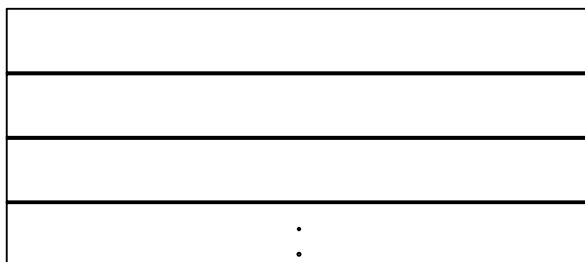

TP1 | TOP PANEL ASSEMBLY-W2A03356
(x1) | 1 5/8"x20 3/16"x45 11/16" (42x512x1160)



SR1 | LEFT TOP PANEL SKIRT ASSEMBLY-W2A03361
(x1) | 11/16"x5 1/4"x21 9/16" (18x134x548)

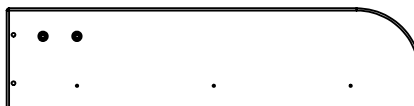

SR2 | RIGHT TOP PANEL SKIRT ASSEMBLY-W2A03362
(x1) | 11/16"x5 1/4"x21 9/16" (18x134x548)

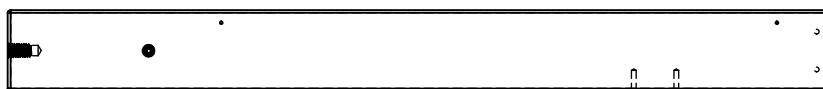

BL2 | BACK LEG LEFT ASSEMBLY-W2A03357
(x1) | 1 1/16"x3 3/8"x34 3/8" (27x86x873)

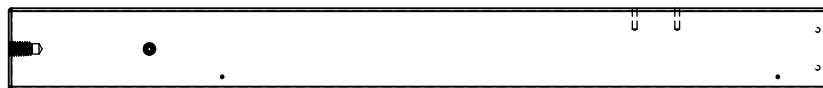

BL1 | BACK LEG RIGHT ASSEMBLY-W2A03358
(x1) | 1 1/16"x3 3/8"x34 3/8" (27x86x873)



FL2 | FRONT LEG LEFT ASSEMBLY-W2A03359
(x1) | 1 1/16"x3 3/8"x34 3/8" (27x86x873)



FL1 | FRONT LEG RIGHT ASSEMBLY-W2A03360
(x1) | 1 1/16"x3 3/8"x34 3/8" (27x86x873)

OWNER'S MANUAL - PARTS IDENTIFICATION

Hardware Components (Not to Scale)

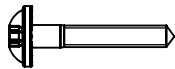

H100403 | LAG SCREW WH BLK
(x7) | 1/4 x 1 1/2

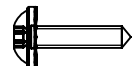

H100460 | LAG SCREW WH BLK
(x4) | 1/4 x 1

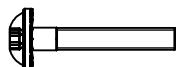

H100406 | BOLT WH BLK
(x4) | 1/4 x 1 1/2

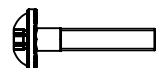

H100397 | BOLT WH BLK
(x4) | 1/4 x 1 1/4



H100405 | WASHER LOCK EXT
(x16) | 6x15 BLK

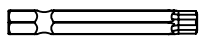

H100147 | TORX BIT
(x1) | T-30

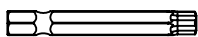

H100879 | TORX BIT
(x1) | T-20



H100886 | SCREW TFH BLK
(x4) | 8 x 1



H100878 | SCREW TFH BLK
(x16) | 8 x 1 1/2



H100889 | SCREW TFH BLK
(x32) | 8 x 1 3/4



H101082 | SCREW TWH BLK
(x4) | 8 x 1



H101090 | SCREW TWH BLK
(x9) | 8 x 1 3/4



H100408 | SCREW PWH BLK
(x2) | 8 x 1/2

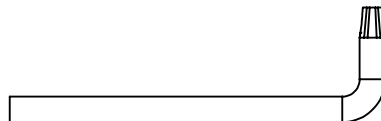

H100114 | TORX WRENCH
(x1) | T-30

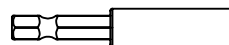

H101100 | MAGNETIC DRIVER
(x1)

OWNER'S MANUAL - PARTS IDENTIFICATION

Accessory Components (Not to Scale)



A100241 | BYD ID TAG
(1)

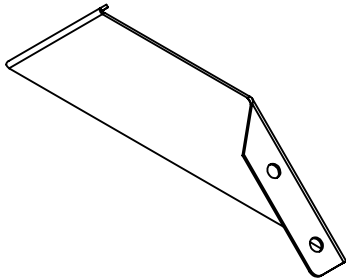

A4M01297 | METAL ANGLE BRACE
(x1)

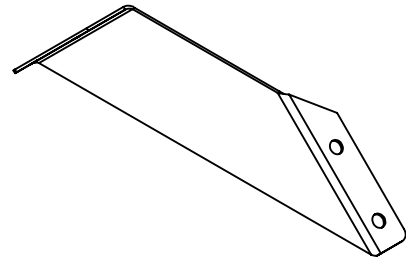

A4M01298 | METAL ANGLE BRACE
(x1)

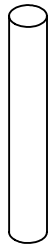

H101099 | DOWEL
(x1) | 5MM

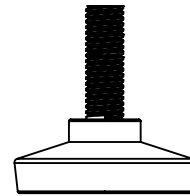

A6P00481 | ADJUSTABLE FOOT
(x4)

PRE-ASSEMBLY STEP 1 - TOOLS REQUIRED



Cordless Drill or
Electric Drill



Drill Attachments:
Phillips Head



Phillips Screw Driver

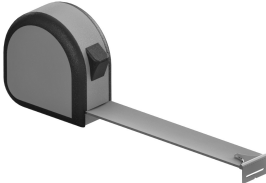

Tape Measure



Claw Hammer

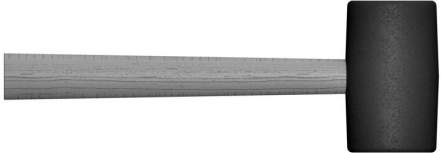

Rubber Mallet -
Optional

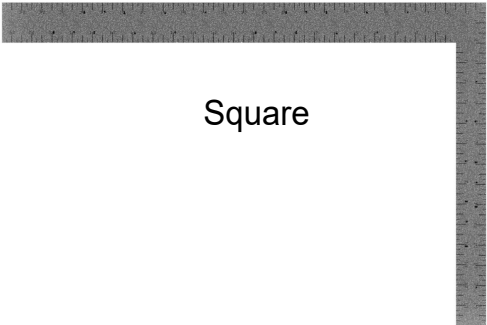

Square



Level 24"

PRE-ASSEMBLY STEP 2 - SORTING PARTS

It is critical for ease of assembly that you take the time to sort and organize the wood and hardware.

WOOD PARTS:

- Organize wood parts by the three-digit, alpha-numeric number stamped on each board (ex. P01).
- If there are multiple boards with the same stamped number, stack those pieces together.
- Stamps can be found on the flat surface of the boards or on the end of the boards.
- Allow yourself plenty of room - the wood pieces can take up a significant amount of space.

NOTE: CARTONS ARE NOT ORGANIZED BY BOARD NUMBER.



HARDWARE PARTS:

- We recommend that you have a separate table to organize the hardware.
- Hardware bags are printed with a seven-digit, alpha-numeric part number.
- You can organize your hardware by part number or group by hardware type (i.e. bolts, nuts, etc.).
- During assembly you only need to reference the last four digits of the number.

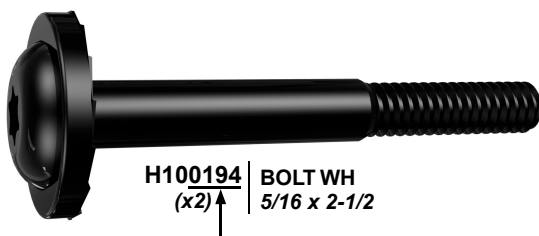

STEP 1 - TABLE ASSEMBLY



FL2 | FRONT LEFT LEG ASSEMBLY-W2A03359
(x1) | 1 1/16"x3 3/8"x34 3/8" (27x86x873)



BL2 | BACK LEG LEFT ASSEMBLY-W2A03357
(x1) | 1 1/16"x3 3/8"x34 3/8" (27x86x873)

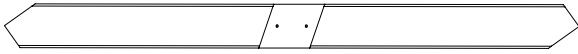

CB1 | CROSS BRACE-W4L15973
(x2) | 1 1/16"x2 3/8"x31" (27x60x787)



FL1 | FRONT LEG RIGHT ASSEMBLY-W2A03360
(x1) | 1 1/16"x3 3/8"x34 3/8" (27x86x873)



BL1 | BACK LEG RIGHT ASSEMBLY-W2A03358
(x1) | 1 1/16"x3 3/8"x34 3/8" (27x86x873)

QTY.	PART NUMBER	DESCRIPTION
4	H101090	SCREW TWH 8 X 1 3/4 BLK

NOTES:
COMPLETE THIS STEP 2 TIMES.

BE SURE TO MATCH BL1 WITH FL1
AND BL2 WITH FL2.

TIP:
PLACE LEGS AND CROSS BRACE
ON A FLAT SURFACE. TOP AND
BOTTOM OF EACH LEG SHOULD
BE ALONG THE SAME PLANE.

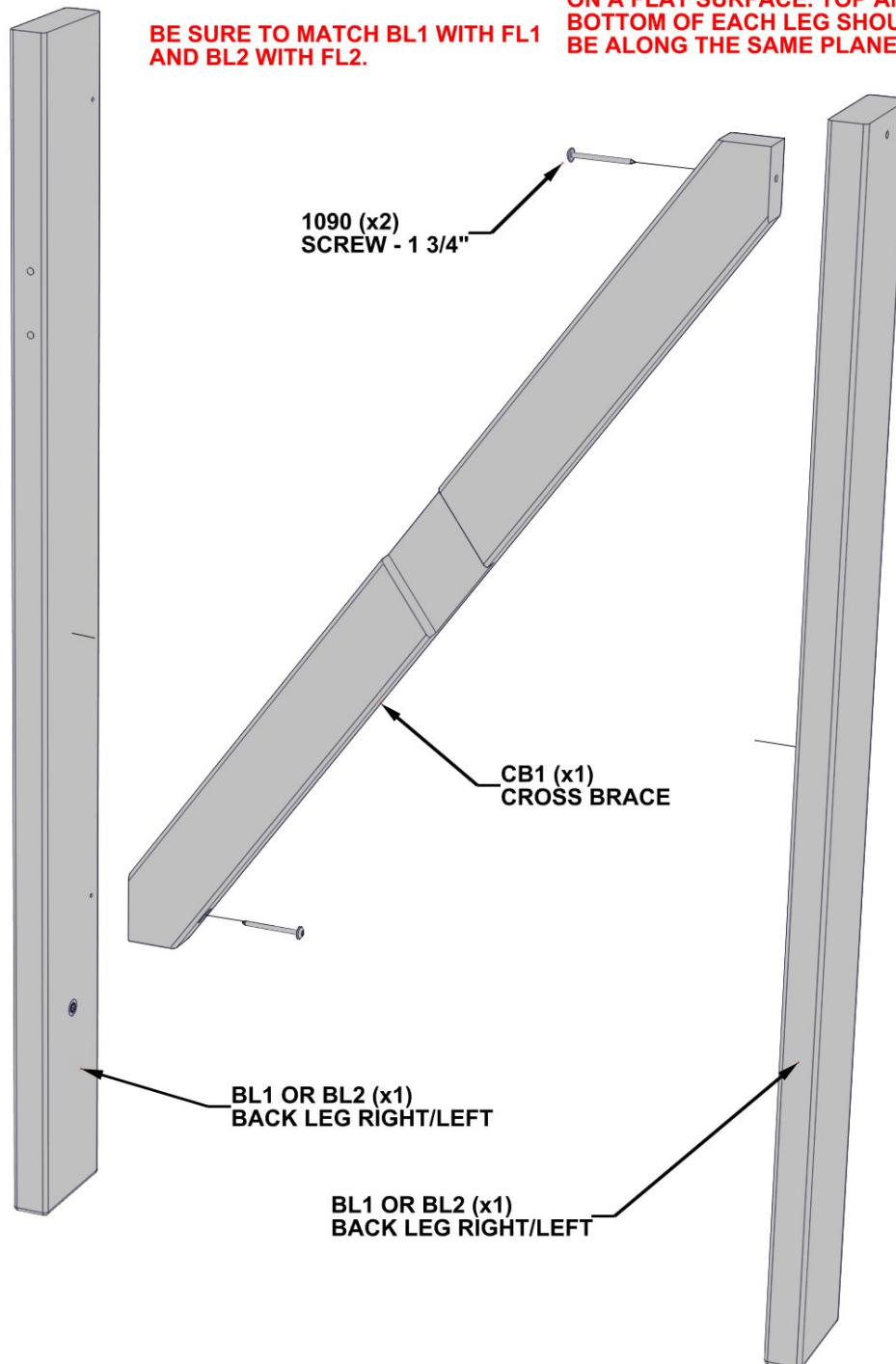

STEP 2 - TABLE ASSEMBLY

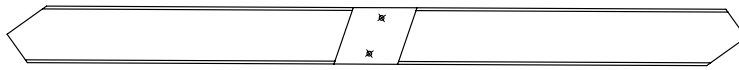

CB2 | CROSS BRACE-W4L15972
 (x2) | 1 1/16"x2 3/8"x30 7/8" (27x60x784)

QTY.	PART NUMBER	DESCRIPTION
4	H100886	SCREW TFH 8 X 1 BLK
4	H101090	SCREW TWH 8 X 1 3/4 BLK

NOTES:
 COMPLETE THIS STEP 2 TIMES.

BE SURE TO MATCH BL1 WITH FL1
 AND BL2 WITH FL2.

TIP:
 PLACE LEGS AND CROSS BRACE
 ON A FLAT SURFACE. TOP AND
 BOTTOM OF EACH LEG SHOULD
 BE ALONG THE SAME PLANE.

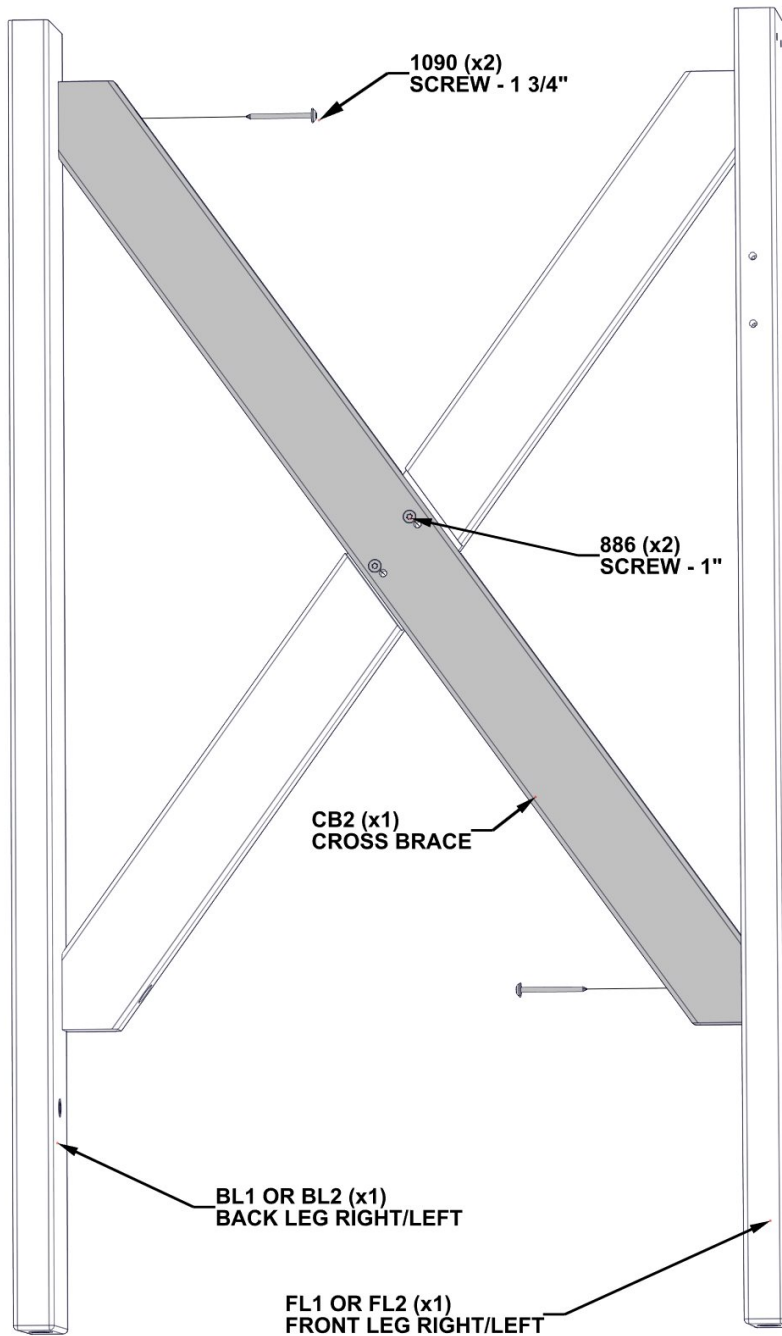

STEP 3 - TABLE ASSEMBLY

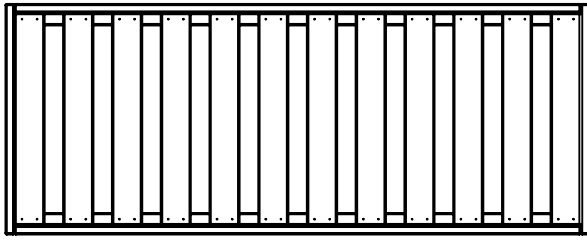

BP1 | BOTTOM PANEL ASSEMBLY-W2A03363
 (x1) | 3"x18 1/16"x45 11/16" (76x458x1160)

QTY.	PART NUMBER	DESCRIPTION
4	H100406	BOLT WH 1/4 X 1 1/2 BLK
4	H100405	WASHER LOCK EXT 6X15 BLK

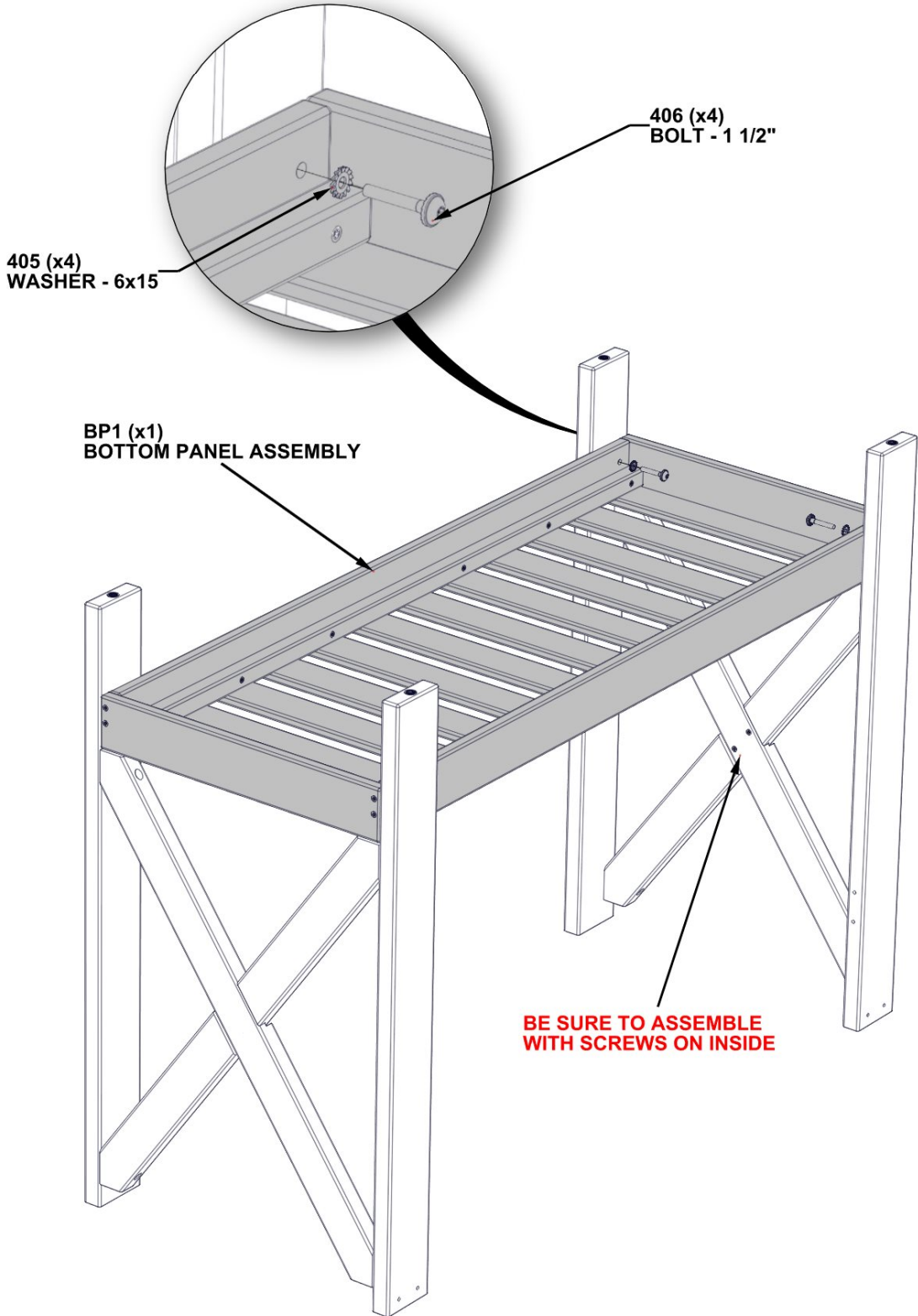

STEP 4 - TABLE ASSEMBLY

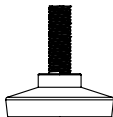

A6P00481
(x4) | **ADJUSTABLE FOOT**

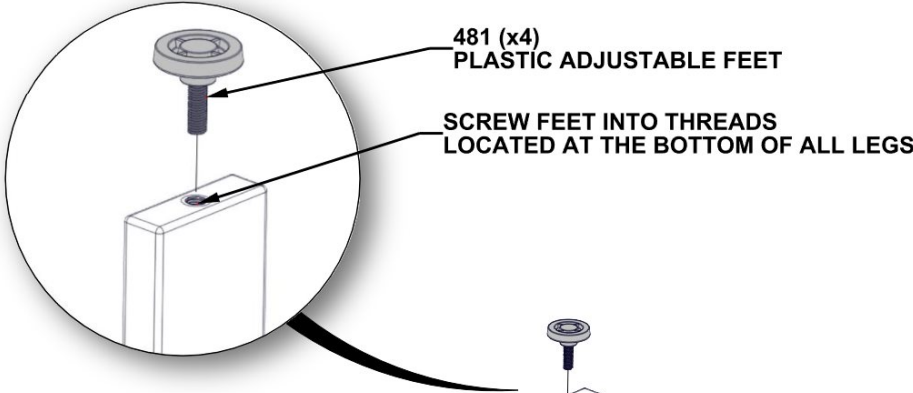

481 (x4)
PLASTIC ADJUSTABLE FEET

SCREW FEET INTO THREADS
LOCATED AT THE BOTTOM OF ALL LEGS

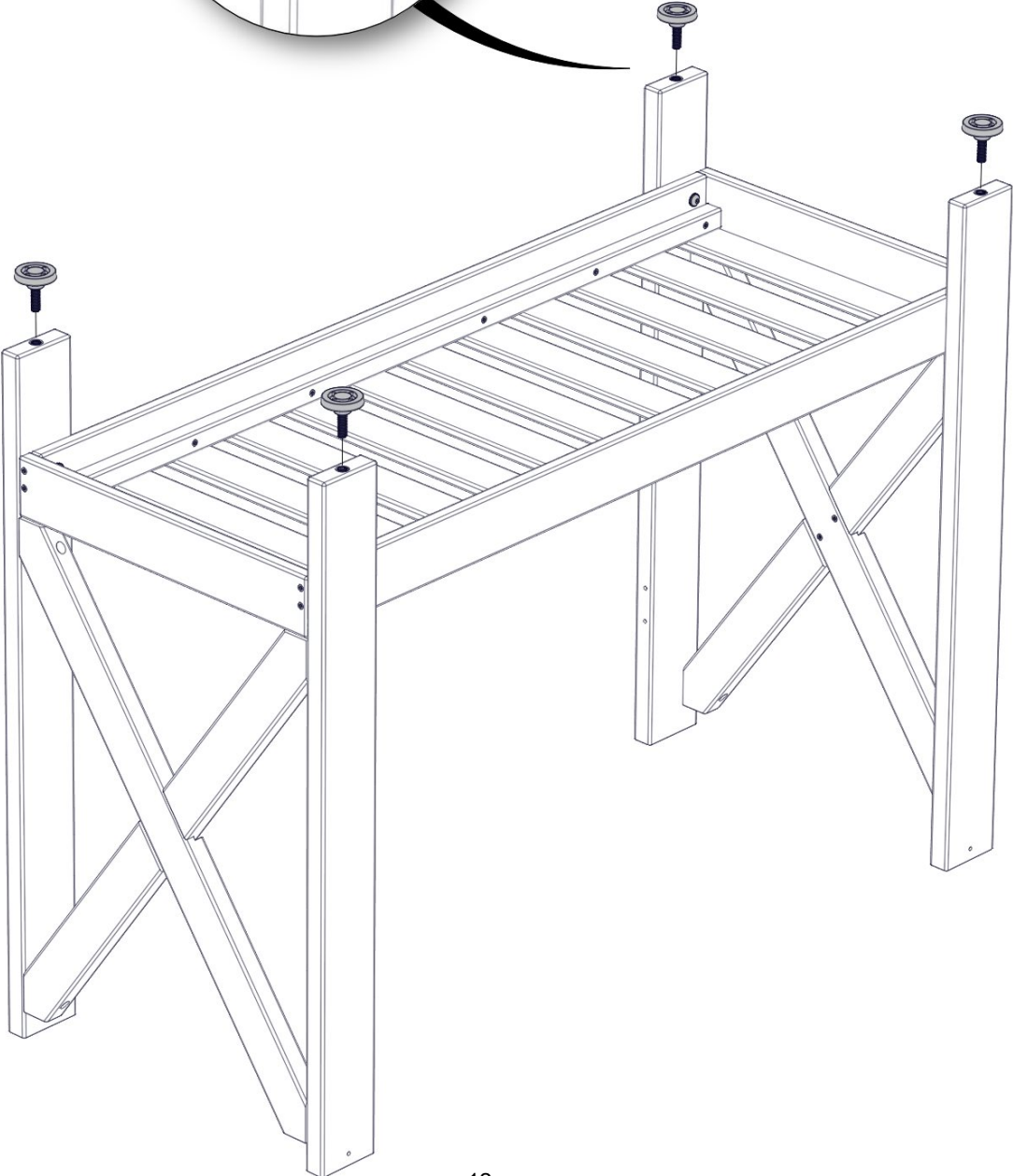

STEP 5 - TABLE ASSEMBLY

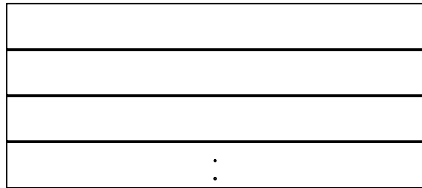

TP1 | TOP PANEL ASSEMBLY-W2A03356
 (x1) | 1 5/8"x20 3/16"x45 11/16" (42x512x1160)

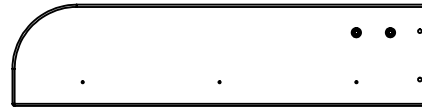

SR1 | LEFT TOP PANEL SKIRT ASSEMBLY-W2A03361
 (x1) | 11/16"x5 1/4"x20 7/8" (18x134x530)

QTY.	PART NUMBER	DESCRIPTION
3	H100878	SCREW TFH 8 X 1 1/2 BLK

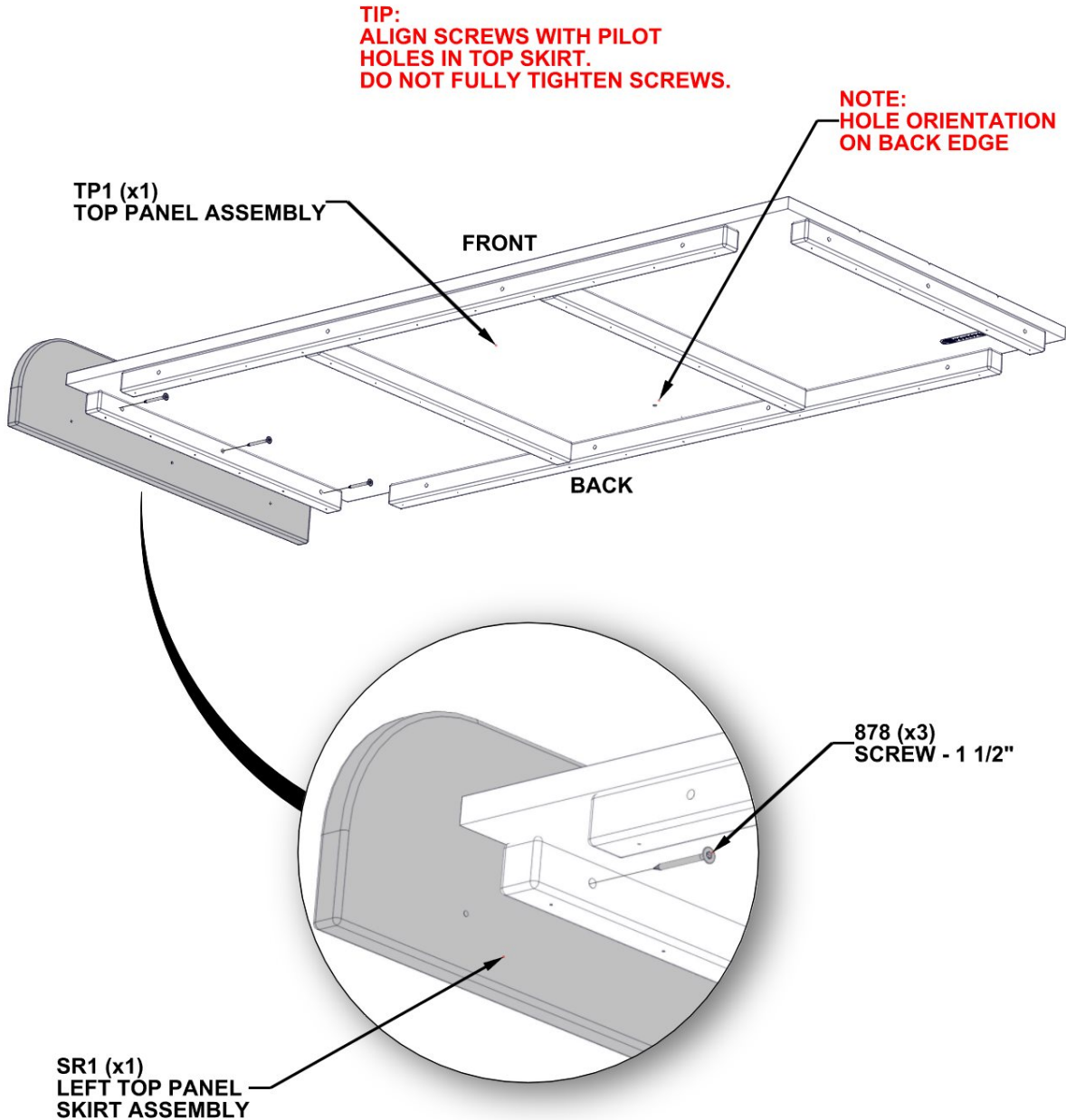

STEP 6 - TABLE ASSEMBLY



SR2 | RIGHT TOP PANEL SKIRT ASSEMBLY-W2A03362
(x1) | 11/16"x5 1/4"x20 7/8" (18x134x530)

QTY.	PART NUMBER	DESCRIPTION
3	H100878	SCREW TFH 8 X 1 1/2 BLK

TIP:
ALIGN SCREWS WITH PILOT
HOLES IN TOP SKIRT.
DO NOT FULLY TIGHTEN SCREWS.

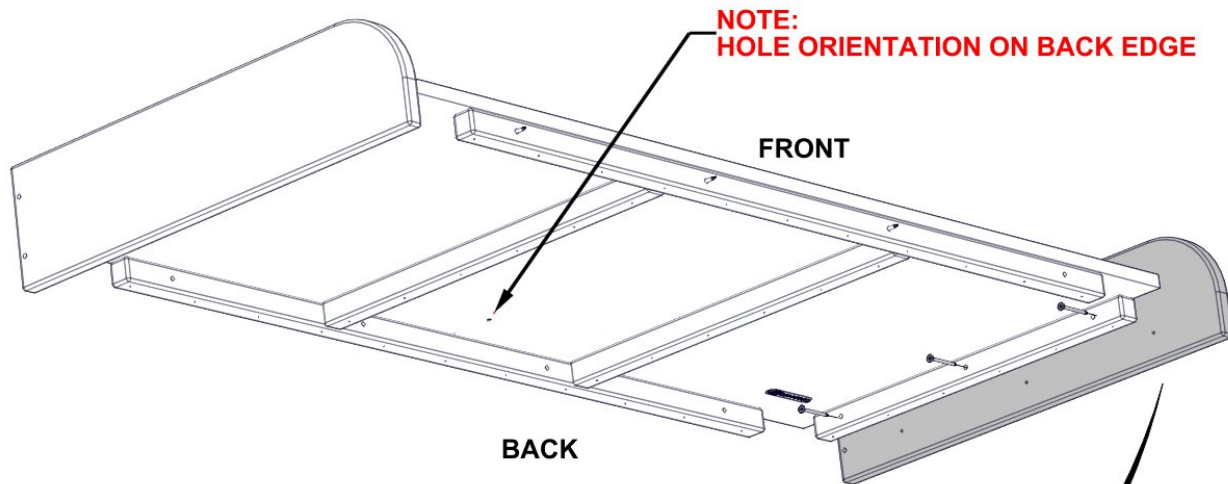

878 (x3)
SCREW - 1 1/2"

SR2 (x1)
RIGHT TOP PANEL
SKIRT ASSEMBLY

STEP 7 - TABLE ASSEMBLY



BP3 | BACK PANEL BOARD-W4L15967
(x1) | 11/16"x5 1/4"x47 1/16" (18x134x1196)

QTY.	PART NUMBER	DESCRIPTION
4	H100889	SCREW TFH 8 X 1 3/4 BLk

NOTE:
ALIGN SCREWS WITH PILOT HOLES.
MAKE SURE EDGES ARE FLUSH.
DO NOT FULLY TIGHTEN SCREWS.

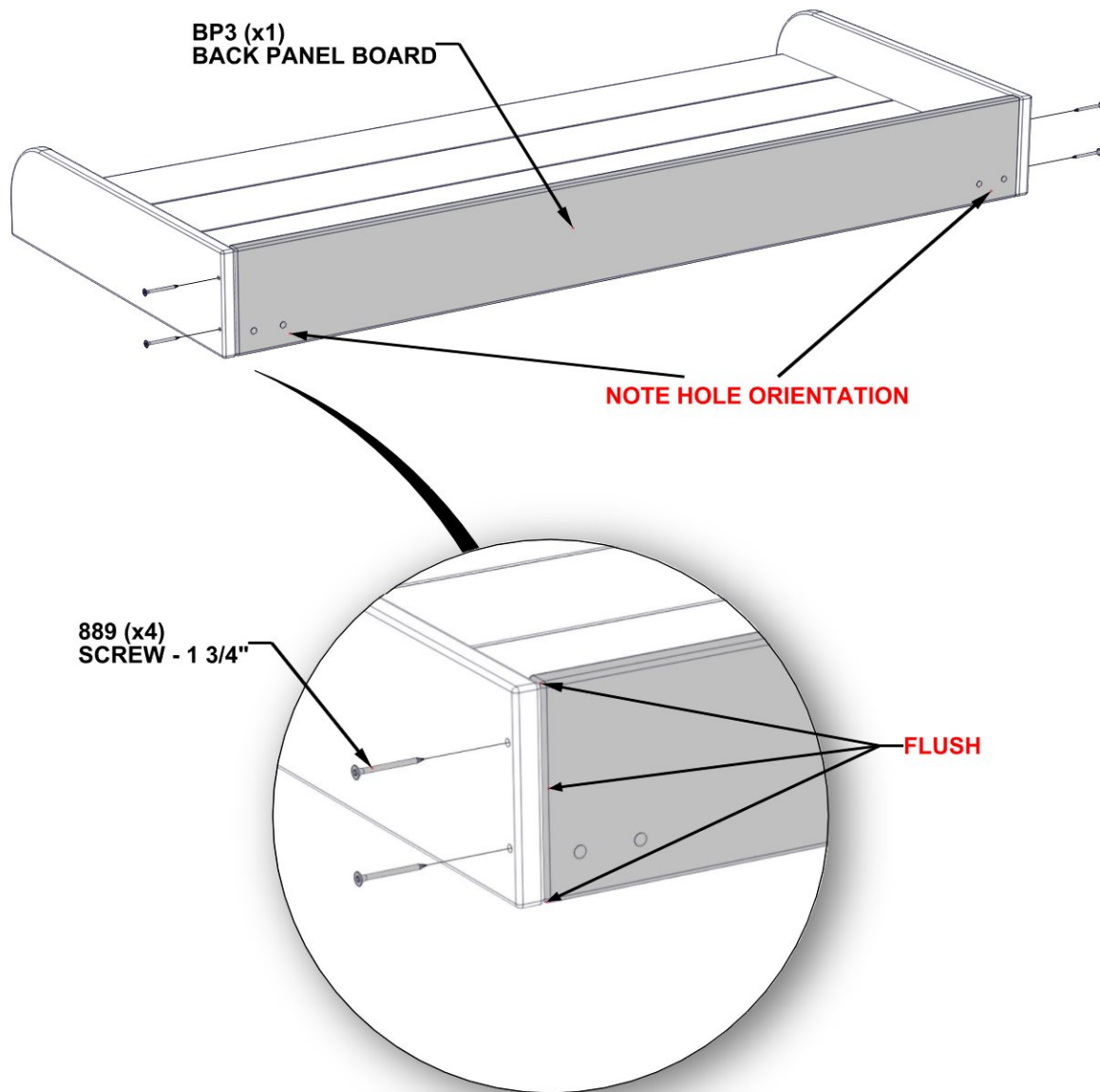

STEP 8 - TABLE ASSEMBLY

QTY.	PART NUMBER	DESCRIPTION
4	H100878	SCREW TFH 8 X 1 1/2 BLK

**TIP: ALIGN SCREWS WITH PILOT HOLES IN BACK PANEL.
FULLY TIGHTEN ALL SCREWS
FROM PREVIOUS STEPS.**

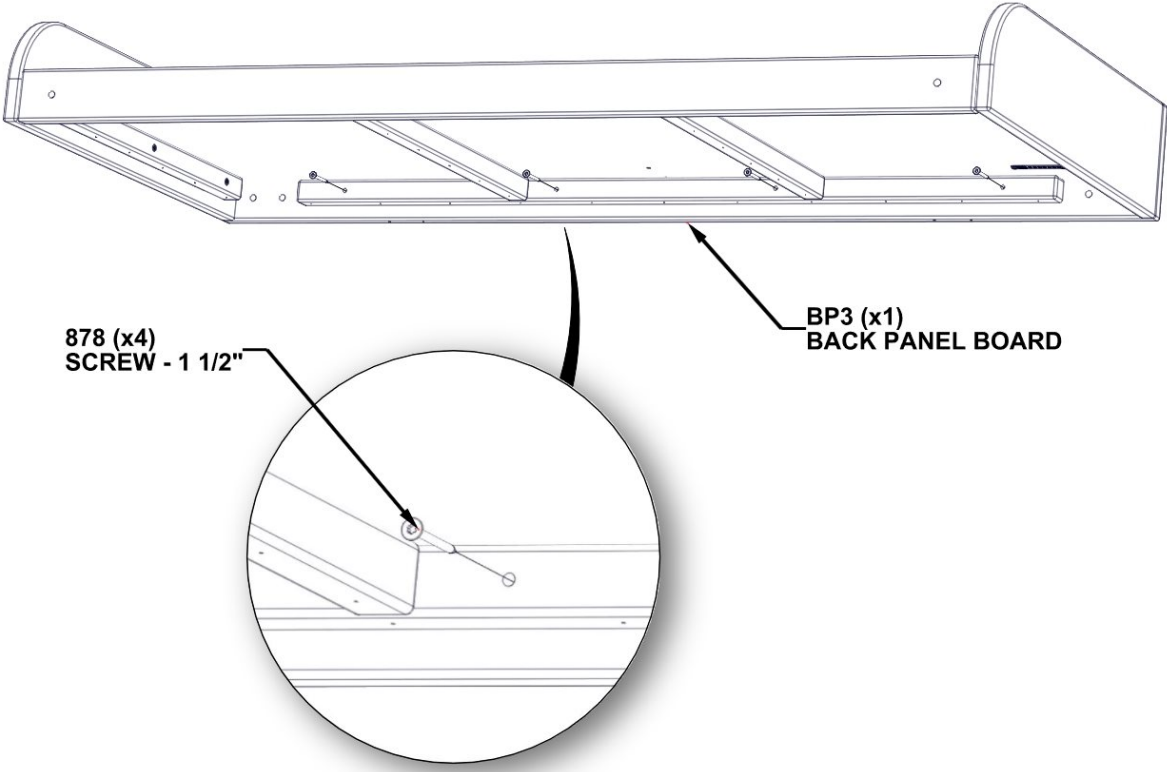

STEP 9 - TABLE ASSEMBLY



FB1 | FRONT BRACE-W4L15970
(x1) | 11/16"x2 3/8"x45 11/16" (18x60x1160)

QTY.	PART NUMBER	DESCRIPTION
4	H100878	SCREW TFH 8 X 1 1/2 BLK

NOTE:
ALIGN SCREWS WITH PILOT HOLES.

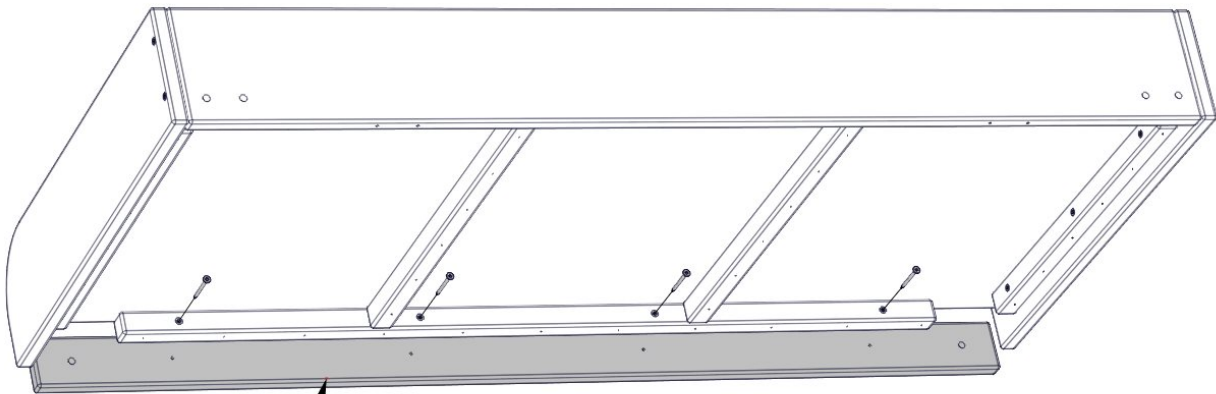

FB1 (x1)
FRONT BRACE

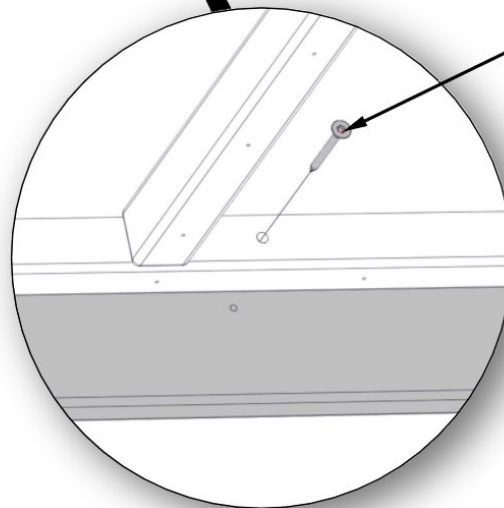

878 (x4)
SCREW - 1 1/2"

STEP 10 - TABLE ASSEMBLY

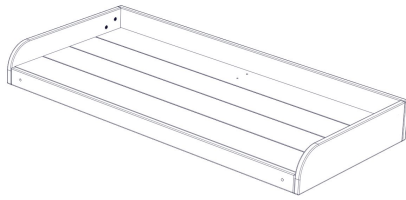

TOP PANEL ASSEMBLY

QTY.	PART NUMBER	DESCRIPTION
6	H100403	LAG SCREW WH 1/4 X 1 1/2 BLK
6	H100405	WASHER LOCK EXT 6X15 BLK

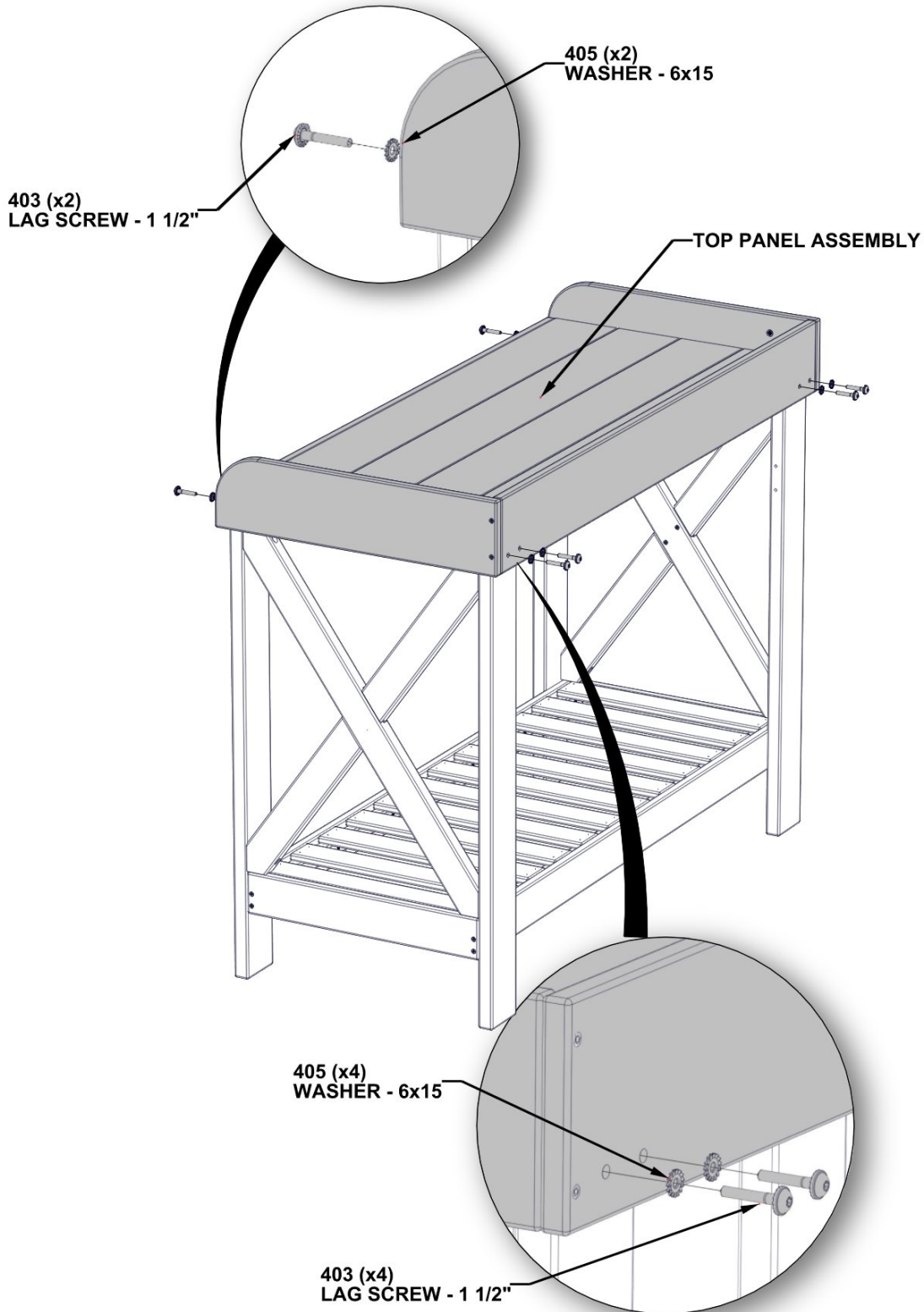

STEP 11 - TABLE ASSEMBLY



BP7 | BACK SHELF UPRIGHT-W4L15965
 (x2) | 11/16"x3 15/16"x17 15/16" (18x100x456)

QTY.	PART NUMBER	DESCRIPTION
4	H100397	BOLT WH 1/4 X 1 1/4 BLK
4	H100405	WASHER LOCK EXT 6X15 BLK

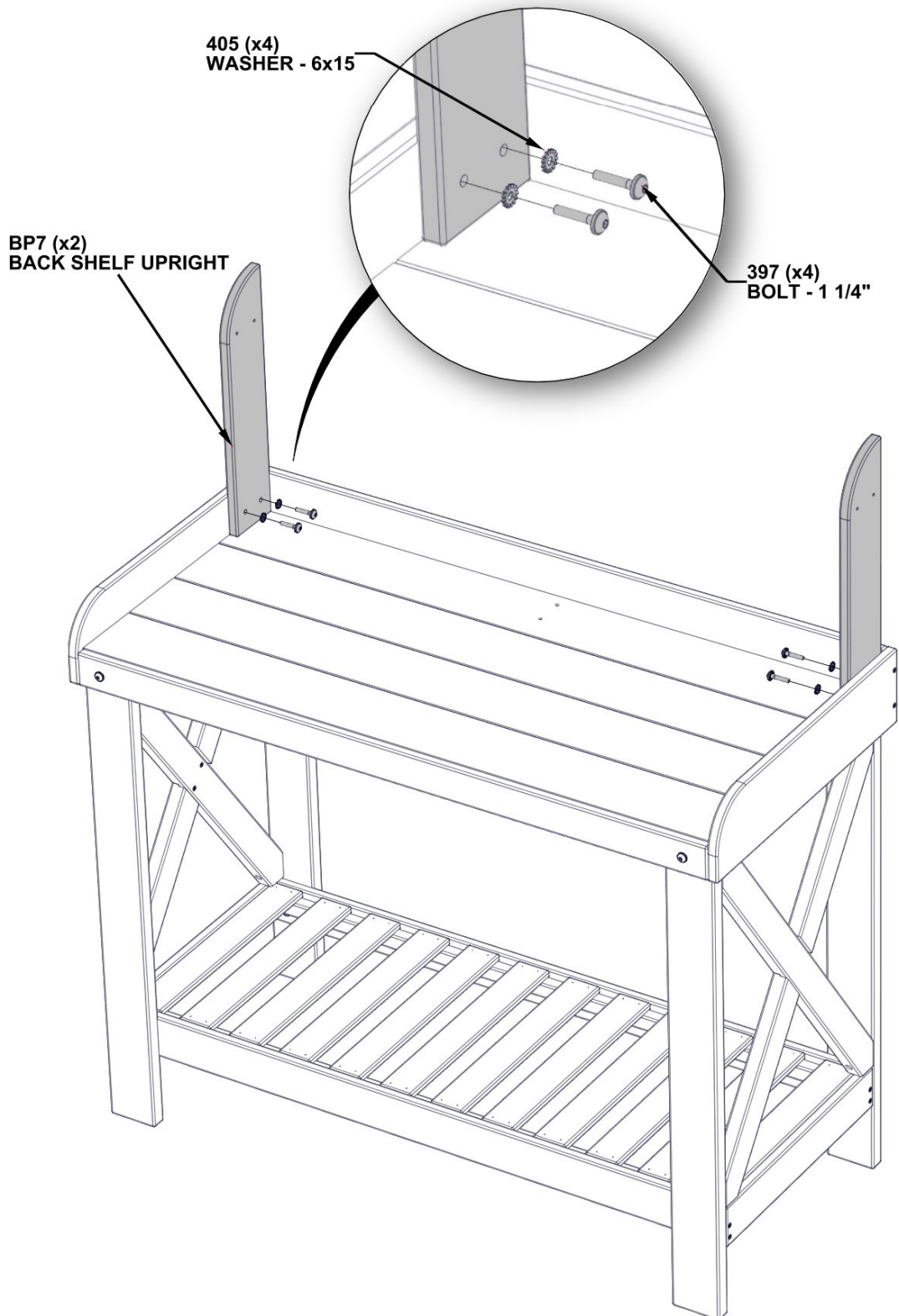

STEP 12 - TABLE ASSEMBLY



BP2 | BACK SHELF MIDDLE UPRIGHT -W4L15966
(x1) | 11/16"x3 15/16"x14" (18x100x356)



H101099 | DOWEL
(x1) | 5MM

QTY.	PART NUMBER	DESCRIPTION
1	H100889	SCREW TFH 8 X 1 3/4 BLk

NOTE:
INSERT DOWEL INTO HOLE. PLACE
BP2 OVER DOWEL, ALIGNING PILOT HOLE.
SCREW FROM BOTTOM SIDE UP.

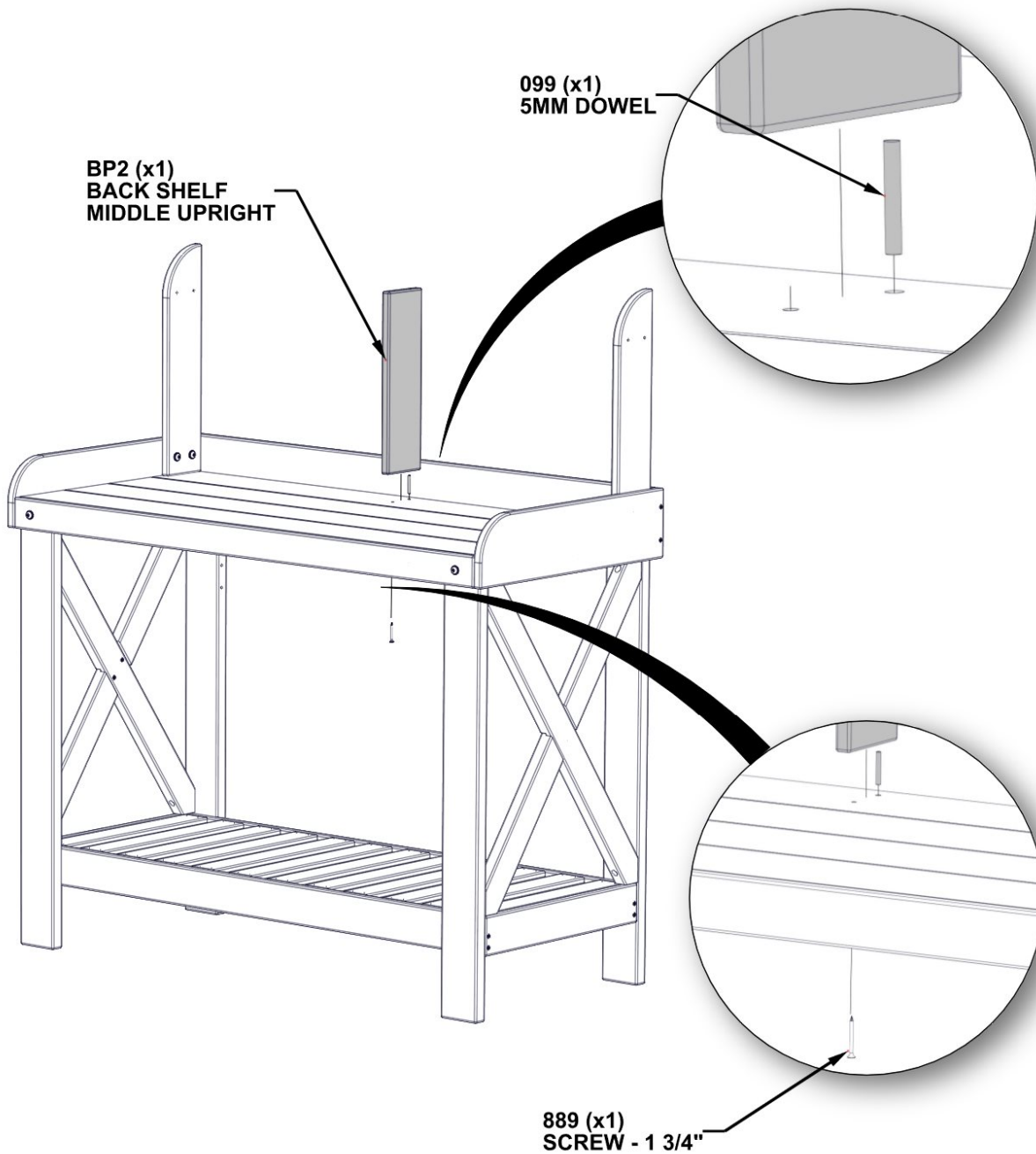

STEP 13 - TABLE ASSEMBLY



BP4 | TOP SHELF BOARD-W4L15968
(x1) | 11/16"x3 15/16"x44 1/4" (18x100x1124)

QTY.	PART NUMBER	DESCRIPTION
6	H100889	SCREW TFH 8 X 1 3/4 BLK

TIP:
ALIGN PILOT HOLES TO CENTER BP4

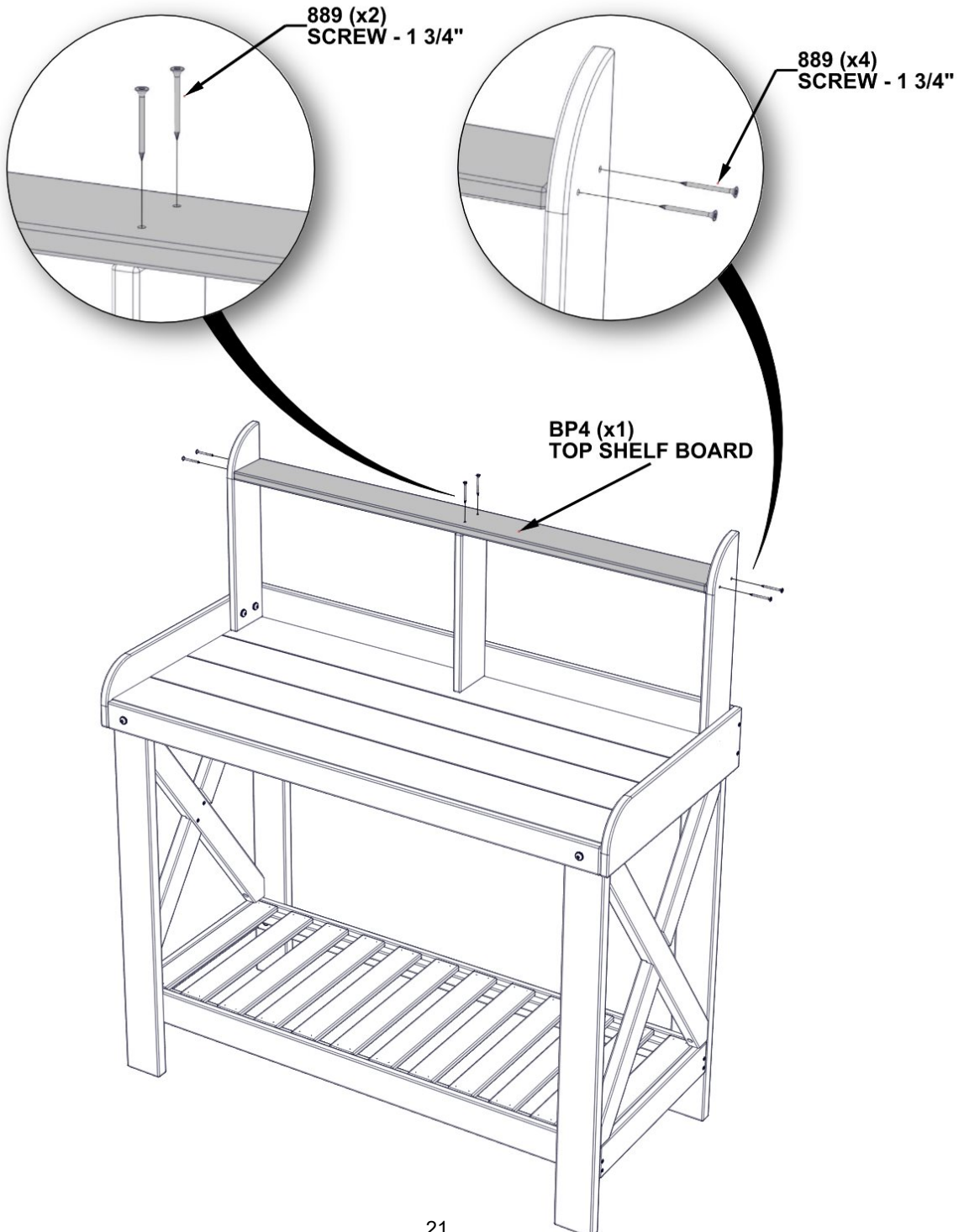

STEP 14 - TABLE ASSEMBLY



BP5 | BACKING BOARD-W4L15969
 (x1) | 11/16"x3 15/16"x45 11/16" (18x100x1160)

QTY.	PART NUMBER	DESCRIPTION
8	H100889	SCREW TFH 8 X 1 3/4 BLk

NOTE:
 ALIGN PILOT HOLES IN BP5.
 MAKE SURE EDGES ARE FLUSH
 BEFORE INSERTING SCREWS.

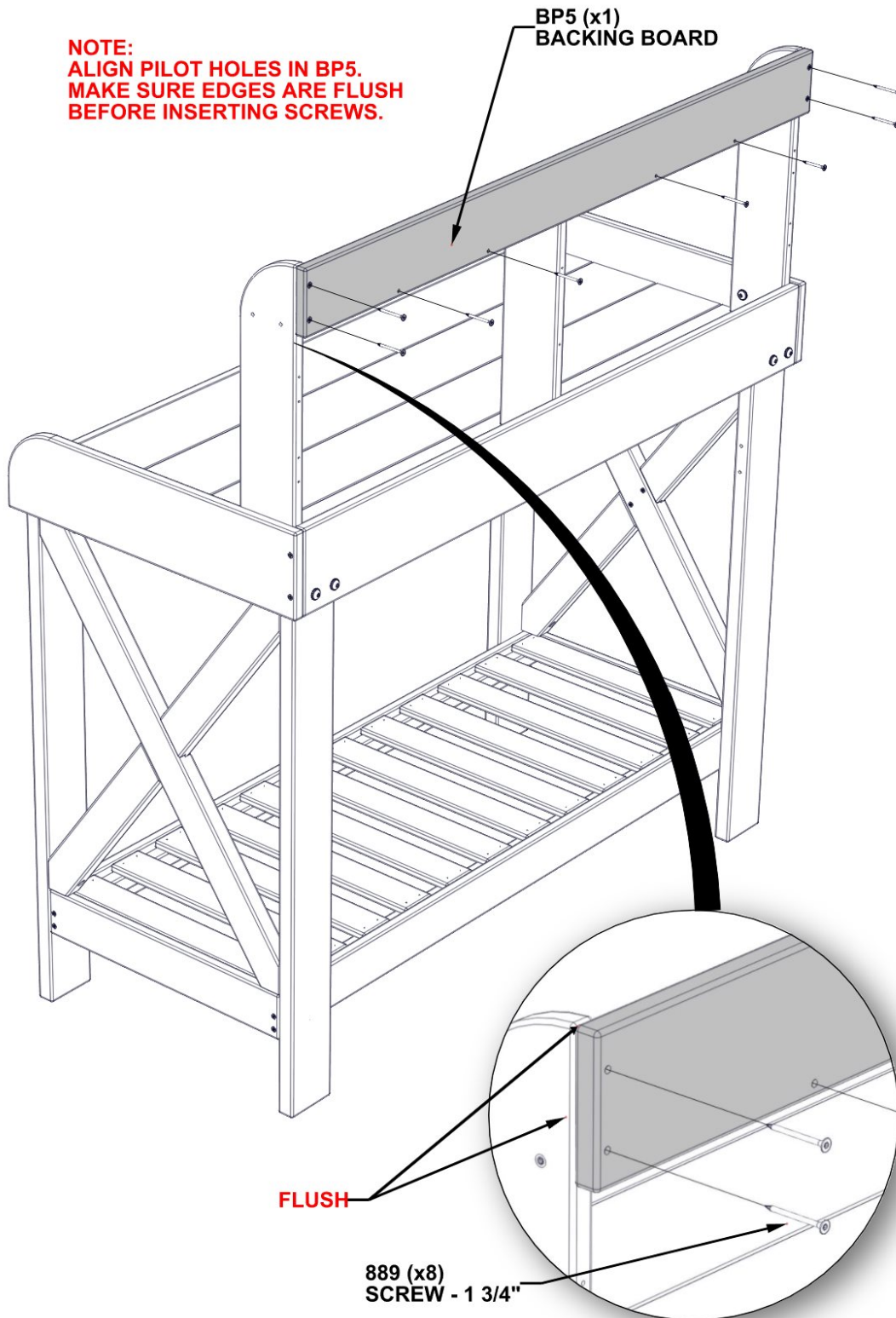

STEP 15 - TABLE ASSEMBLY



BP6 | BACK BOARD-W4L16230
(x2) | 11/16"x3"x45 11/16" (18x76x1160)

QTY.	PART NUMBER	DESCRIPTION
10	H100889	SCREW TFH 8 X 1 3/4 BLK

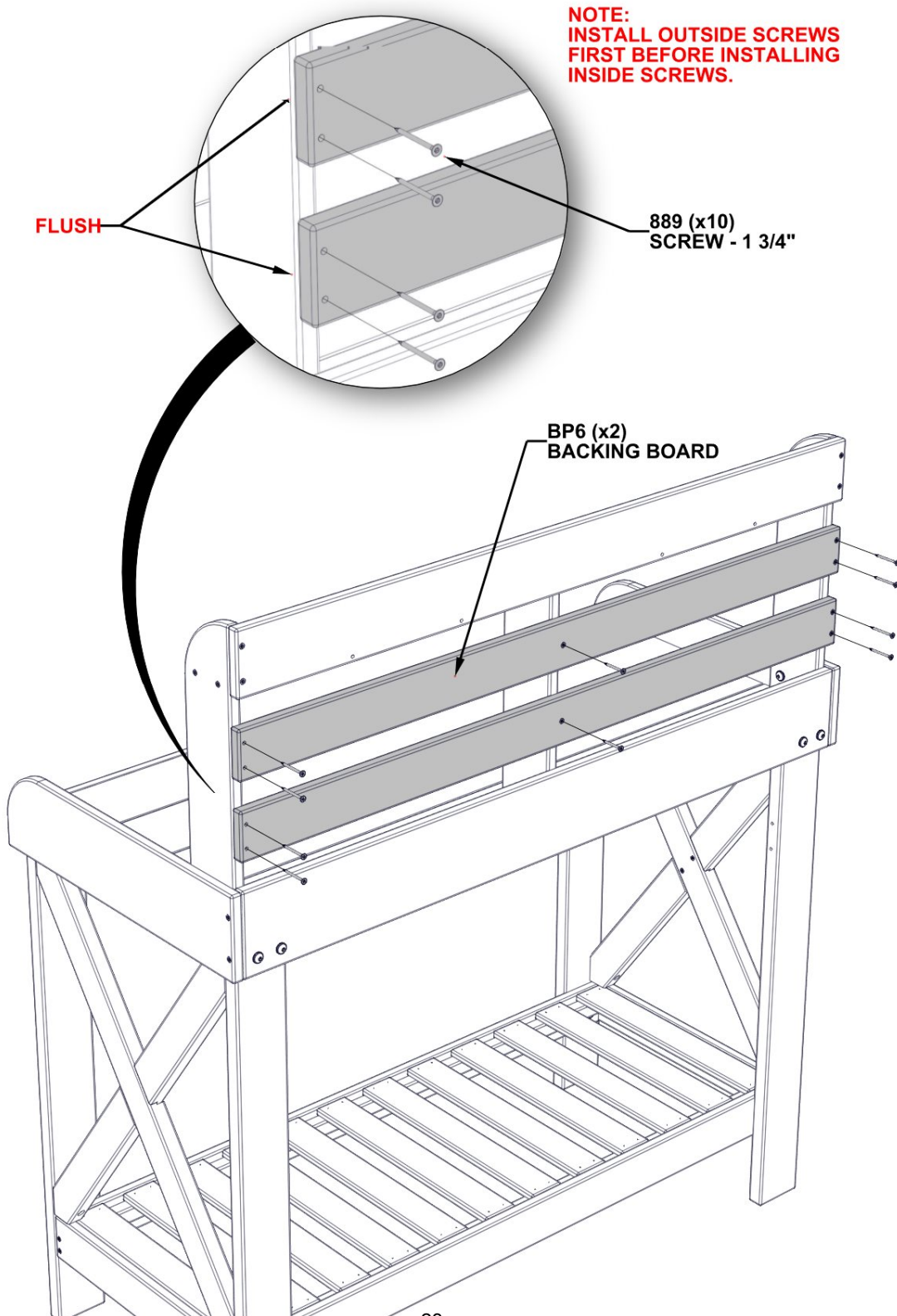

STEP 16 - TABLE ASSEMBLY

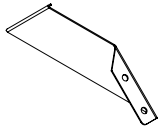

A4M01297
(x1) METAL ANGLE BRACE

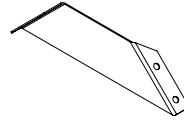

A4M01298
(x1) METAL ANGLE BRACE

QTY.	PART NUMBER	DESCRIPTION
4	H100460	LAG SCREW WH 1/4 X 1 BLK
4	H101082	SCREW TWH 8 X 1 BLK

NOTE:
SMALL HOLES IN BRACE
ATTACH TO TOP PANEL

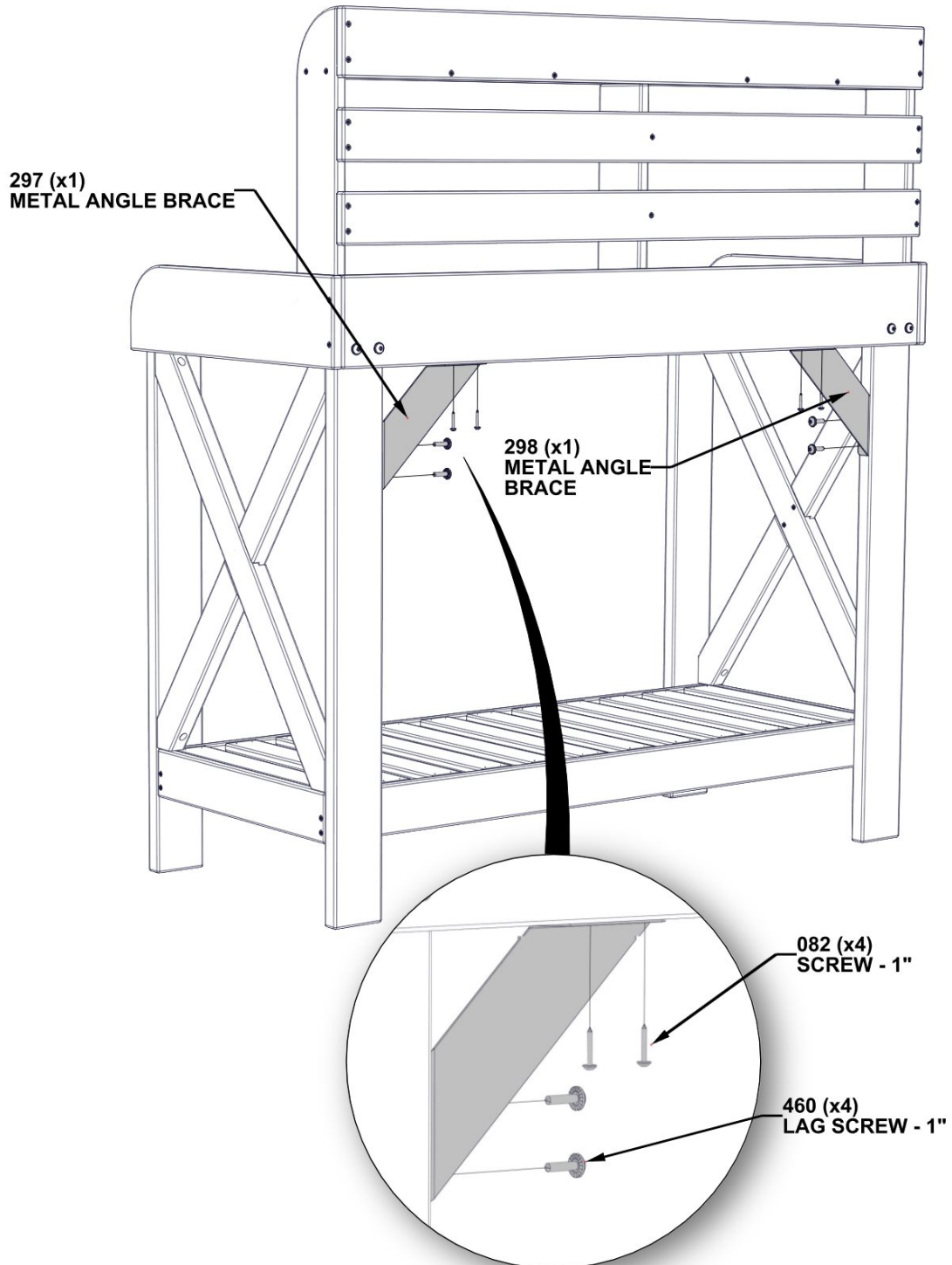

STEP 17 - TABLE ASSEMBLY



A100241
(1) | BYD ID TAG

QTY.	PART NUMBER	DESCRIPTION
2	H100408	SCREW PWH 8 X 1/2 BLK

CENTER ID TAG ON BACKING BOARD

