

2206021B-14x12 NORWOOD GAZEBO Container Loading Diagram

(1 set=6 boxes, 50 sets/40HQ, 20 pallets/ 40HQ, Gross Weight:21050kg)

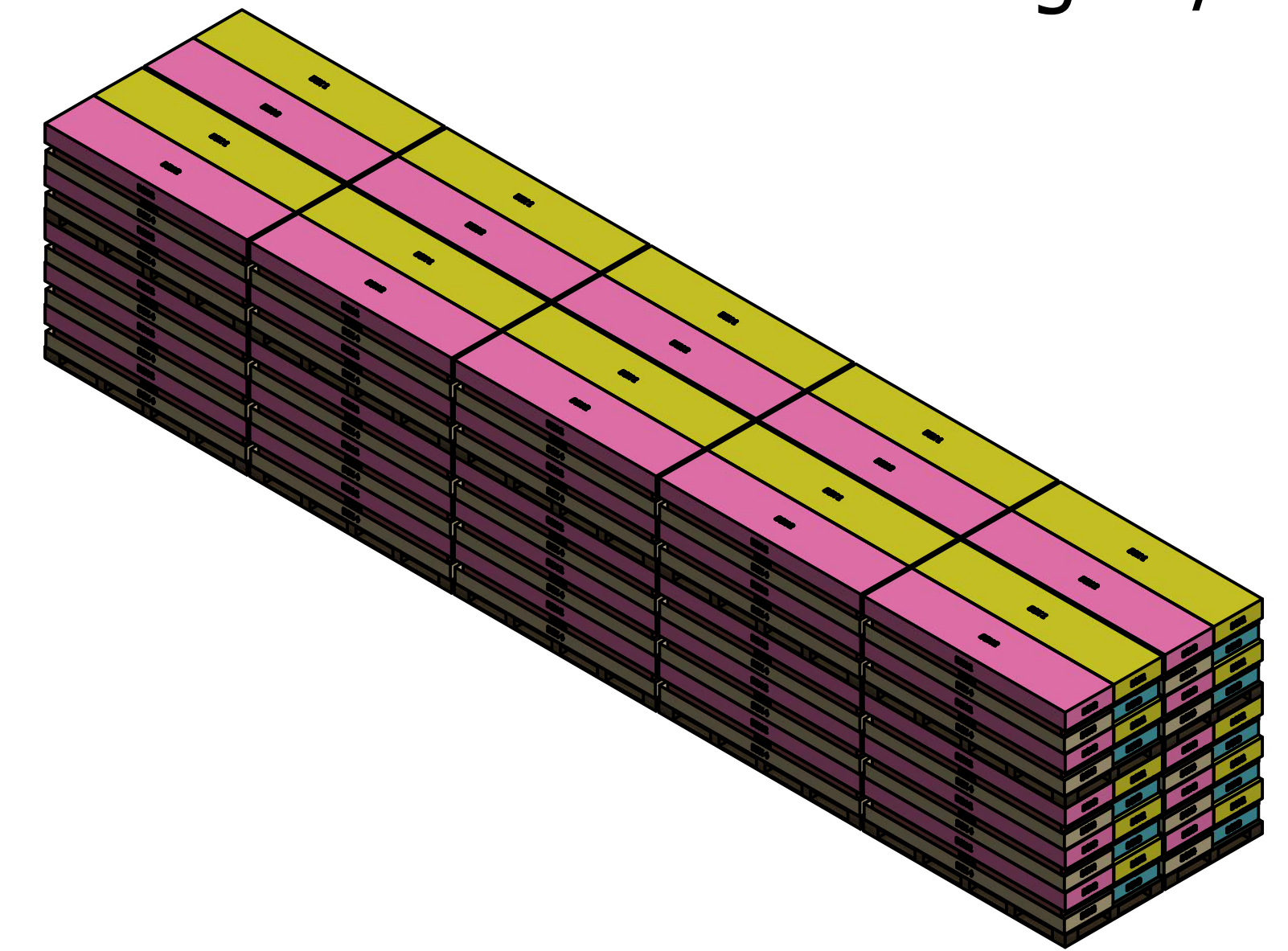

Top view

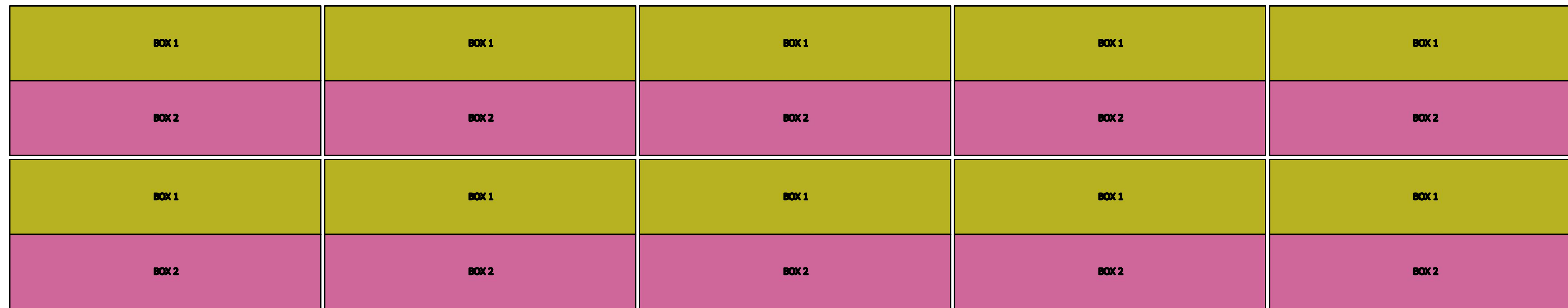

Side view

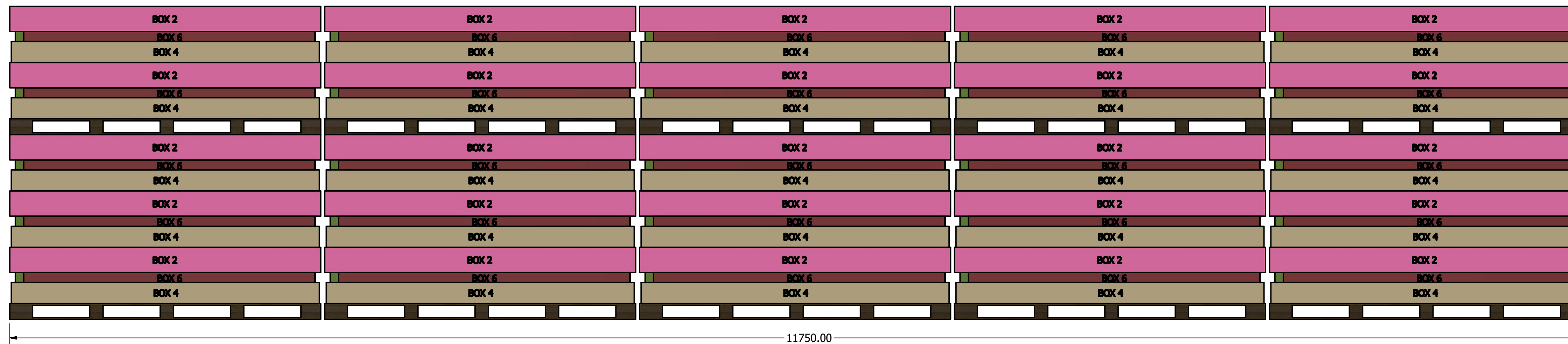

End view

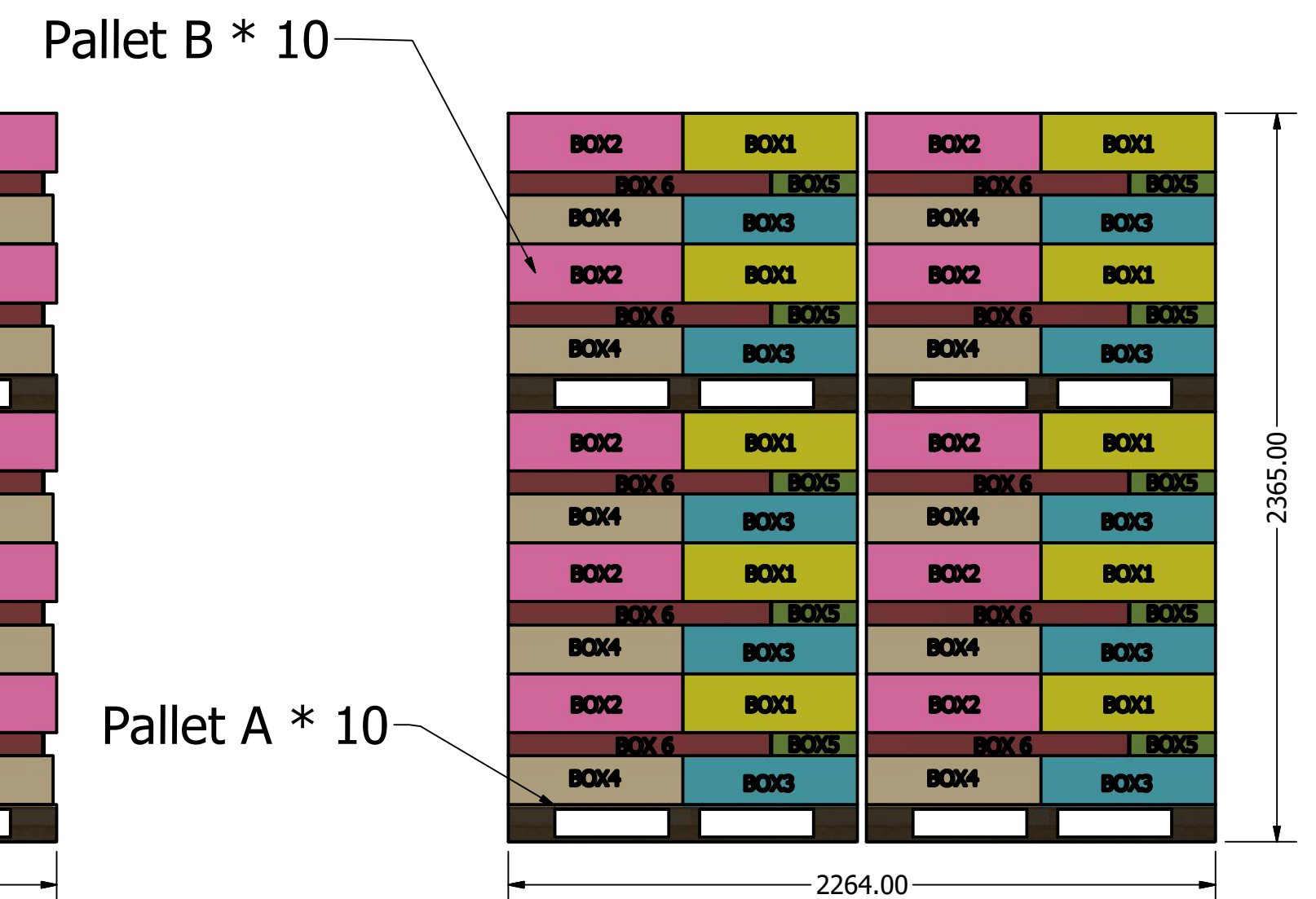

| | | | | |
|---------------|--|--------------|--------|-----|
| DRAWN Rudy | | TITLE | | |
| CHECKED | | | | |
| QA | | SIZE D | DWG NO | REV |
| MFG | | SCALE 1 / 20 | | |
| APPROVED | | SHEET 1 OF 1 | | |

Pallet A (3 sets/pallet)

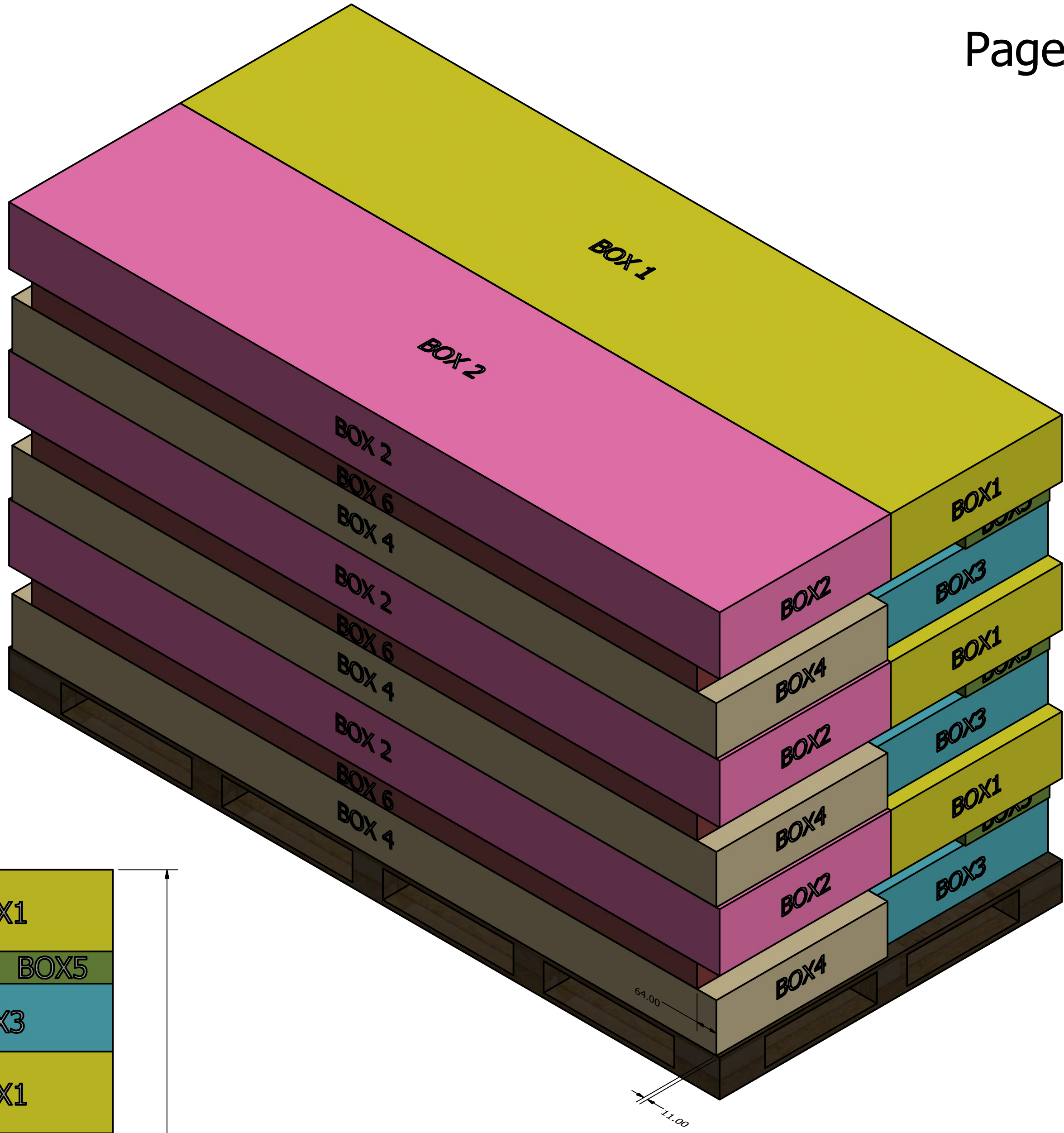
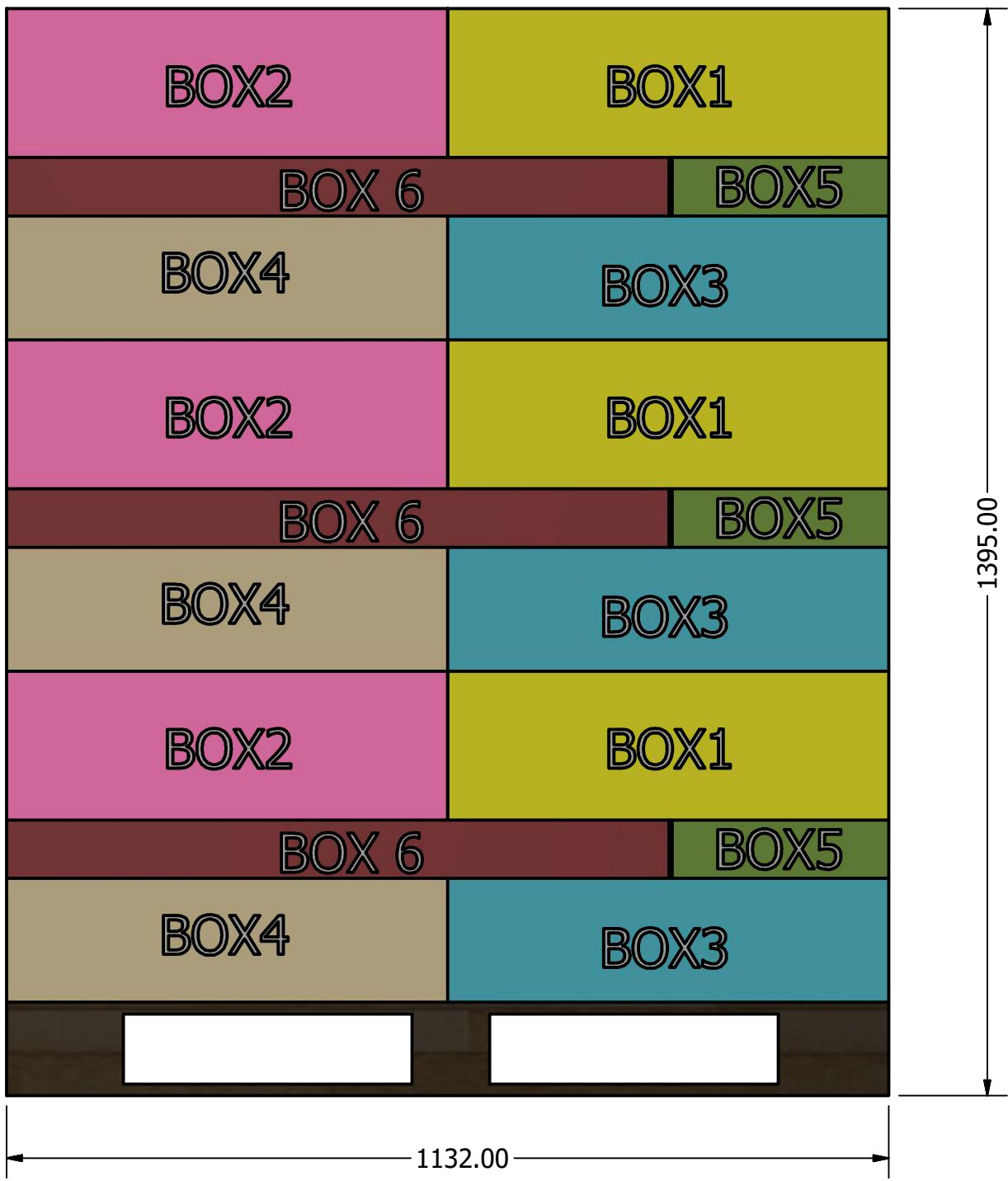
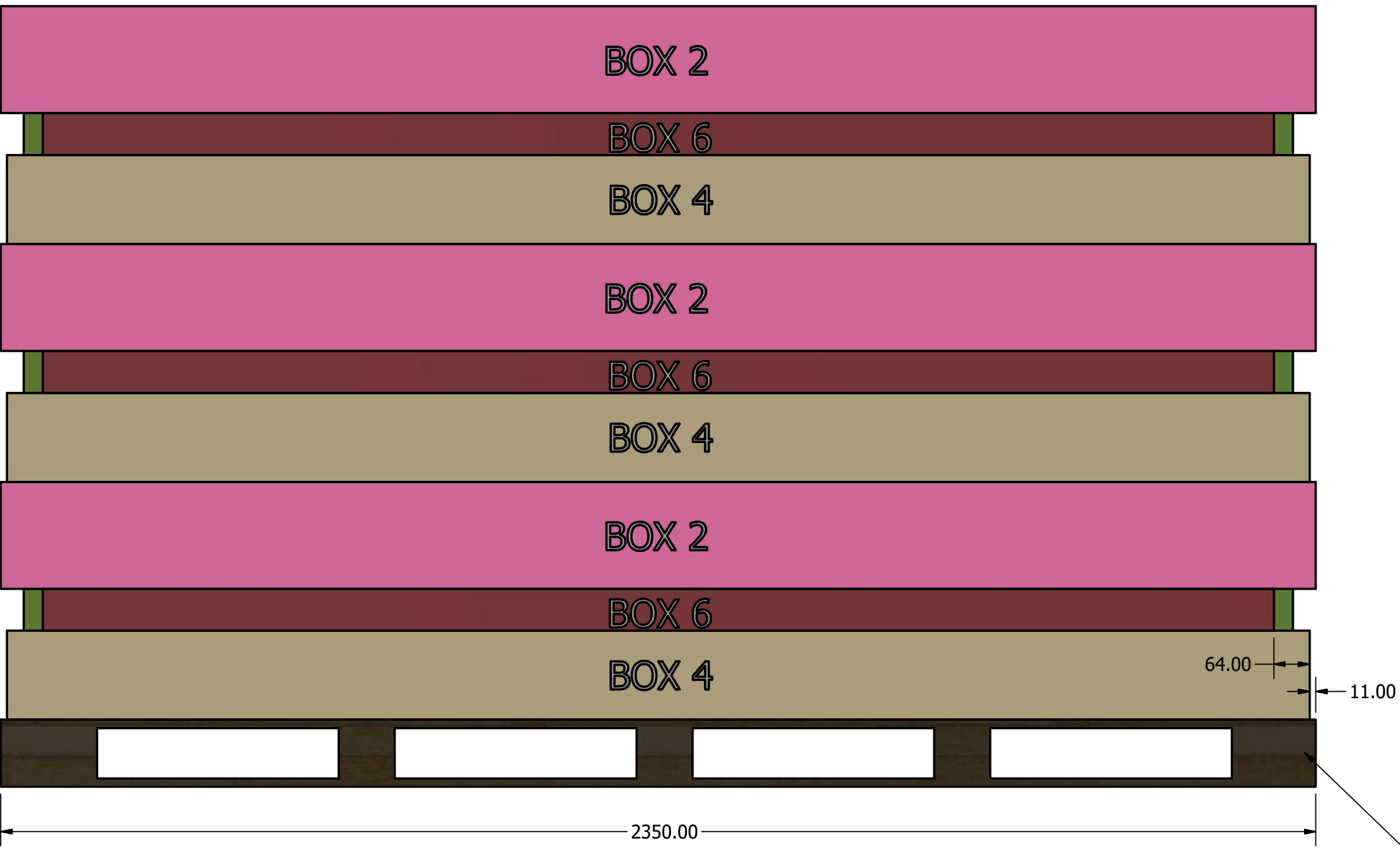
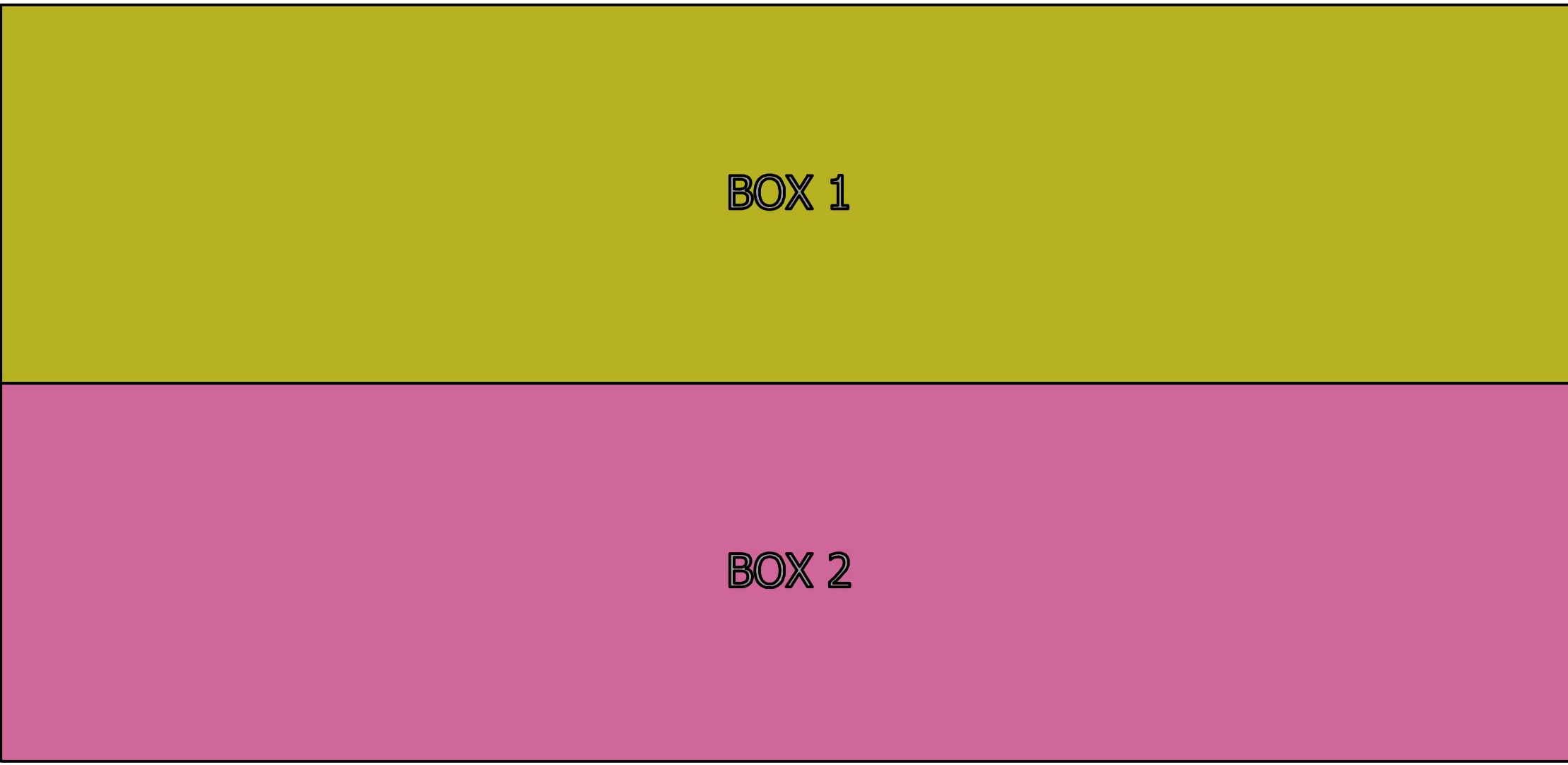

由于这款的BOX3盒子较短，为了保证这个盒子的端头和托盘接触位置能受力，这款产品用的托盘端头的横板宽度必须要达到150mm.

| | | | | |
|----------|------|-----------|--------------|----------|
| DRAWN | Rudy | 2019/8/19 | | |
| CHECKED | | | TITLE | |
| QA | | | | |
| MFG | | | | |
| APPROVED | | | | |
| | | | SIZE | DWG NO |
| | | | D | Pallet A |
| | | | SCALE | REV |
| | | | 1 : 8 | |
| | | | SHEET 1 OF 1 | |

Pallet A (2 sets/pallet)

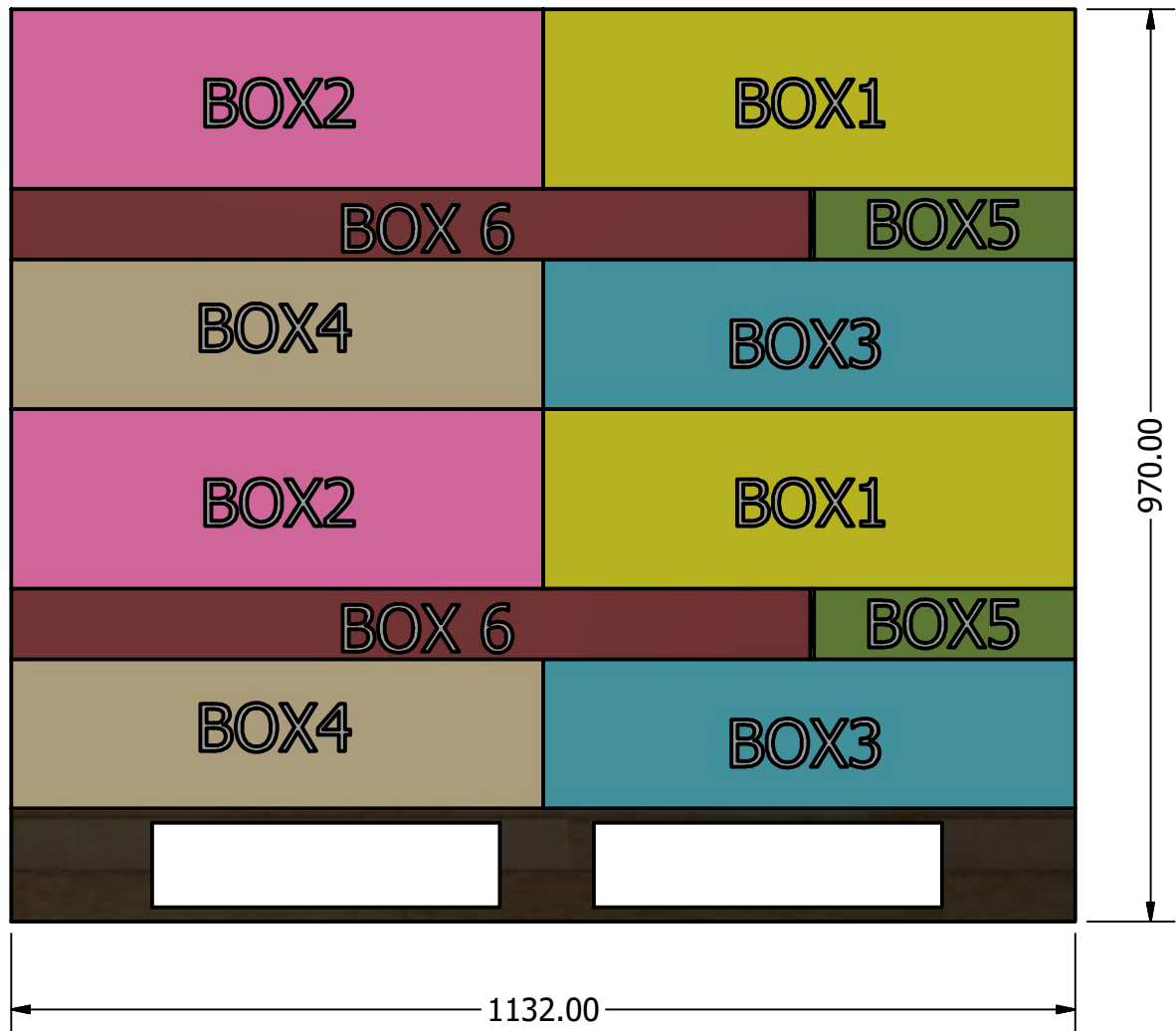
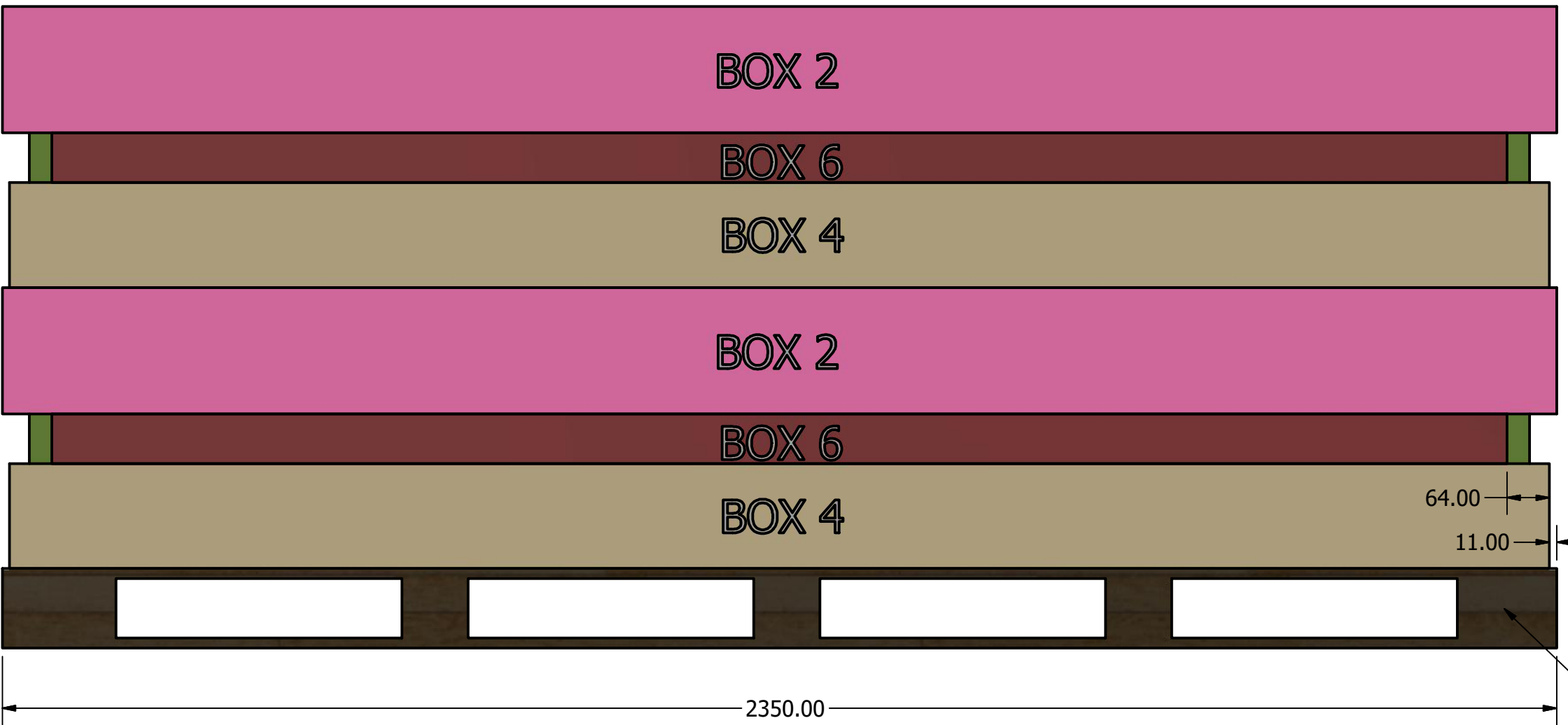
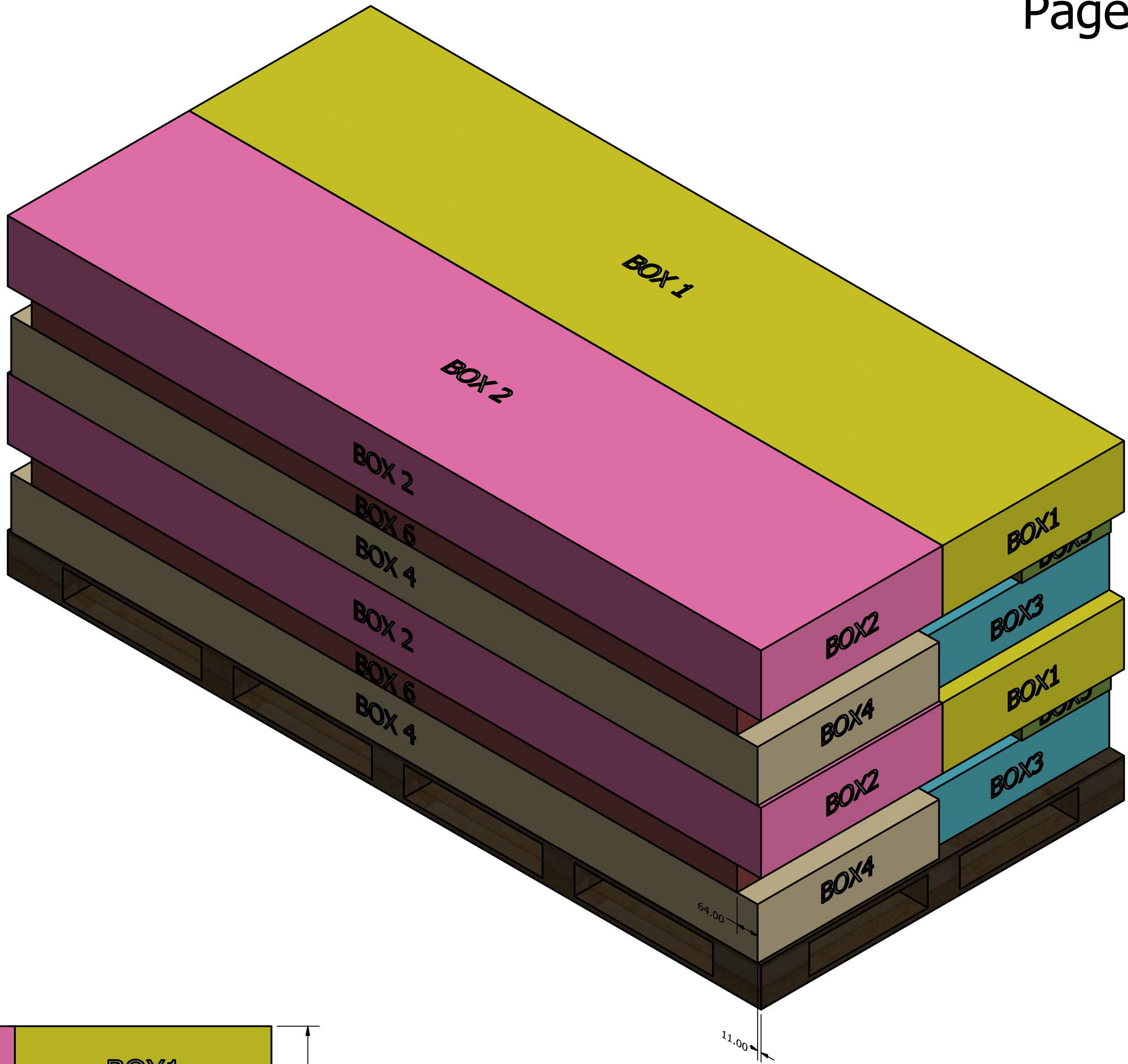
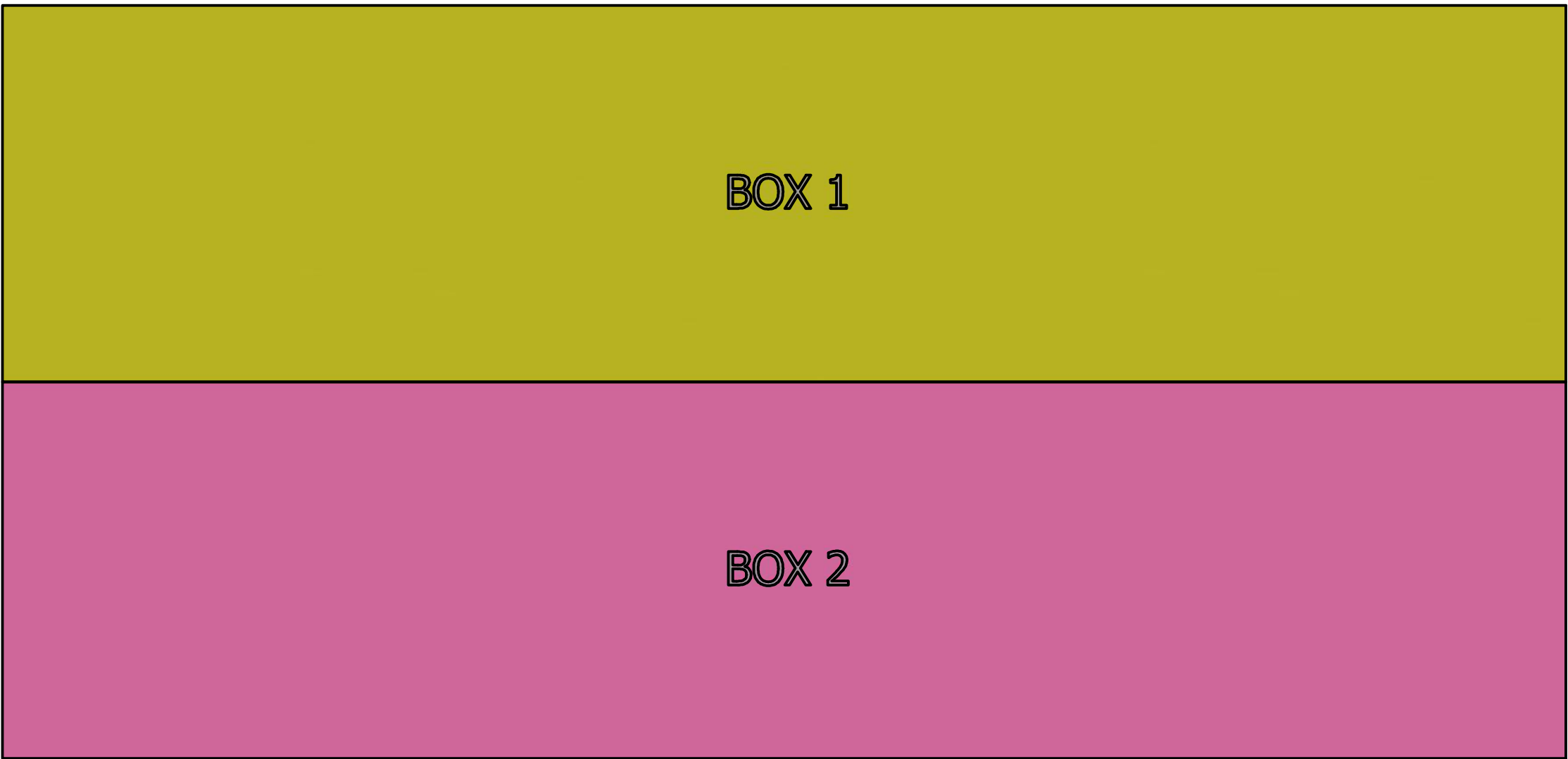

由于这款的BOX3盒子较短, 为了保证这个盒子的端头和托盘接触位置能受力, 这款产品用的托盘端头的横板宽度必须要达到150mm.

| | | | | |
|----------|------|-----------|--------------|----------|
| DRAWN | Rudy | 2019/8/19 | TITLE | |
| CHECKED | | | | |
| QA | | | | |
| MFG | | | | |
| APPROVED | | | | |
| | | | SIZE | DWG NO |
| | | | D | Pallet A |
| | | | SCALE | 1 / 8 |
| | | | SHEET 1 OF 1 | |

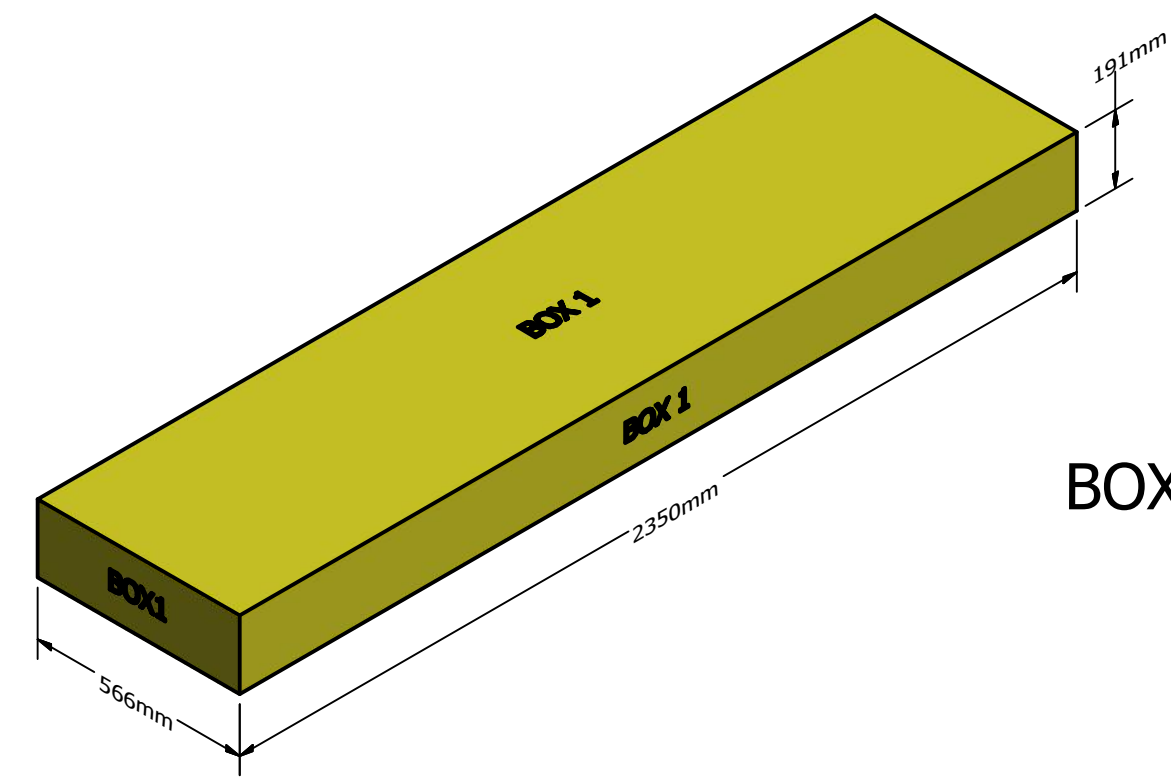

BOX1: 77kg

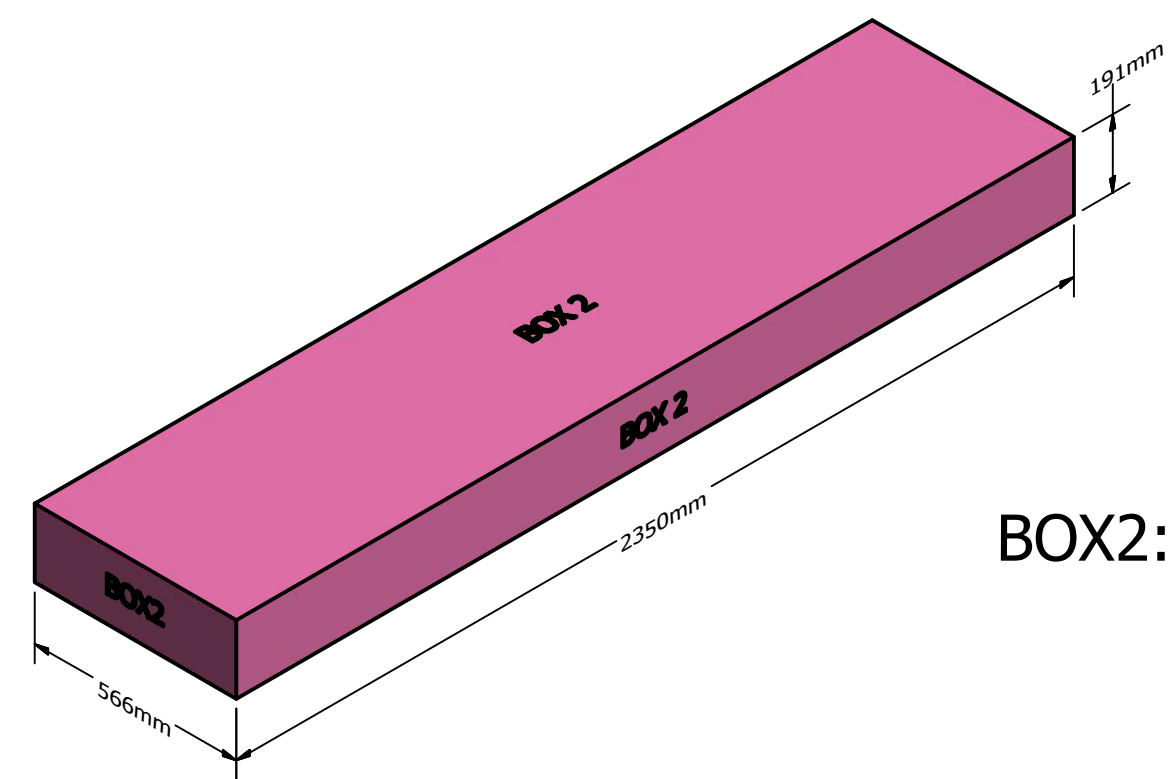

BOX2: 92kg

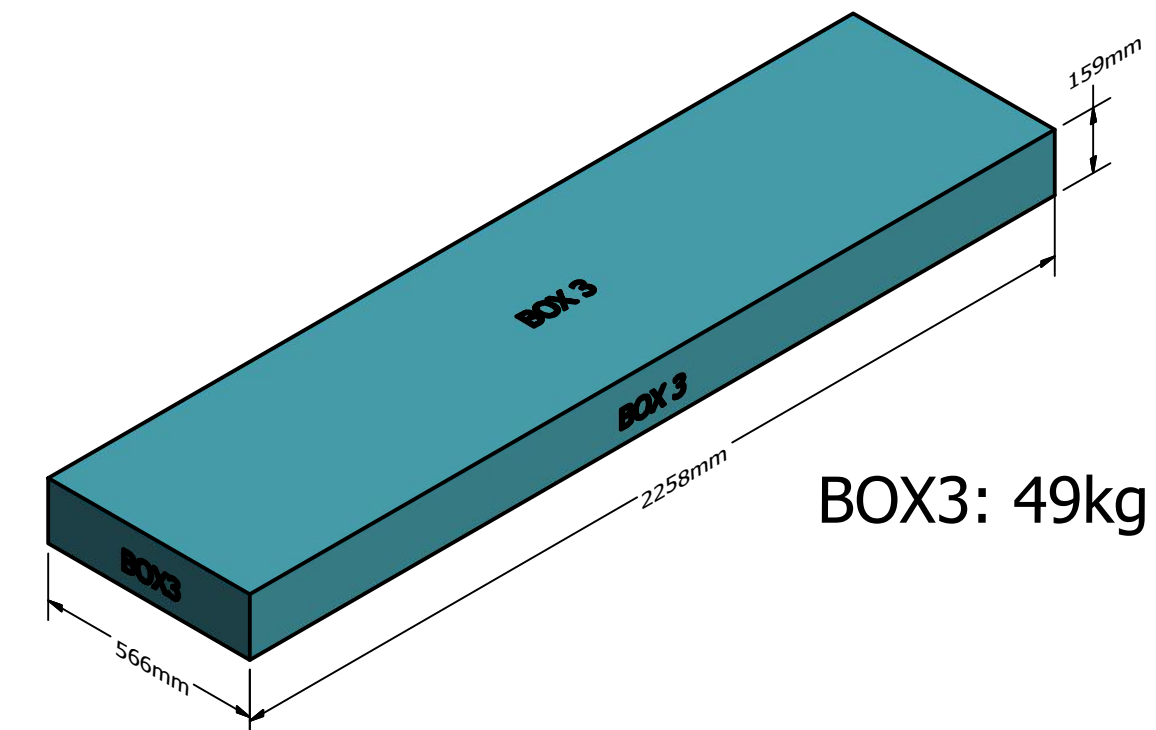

BOX3: 49kg

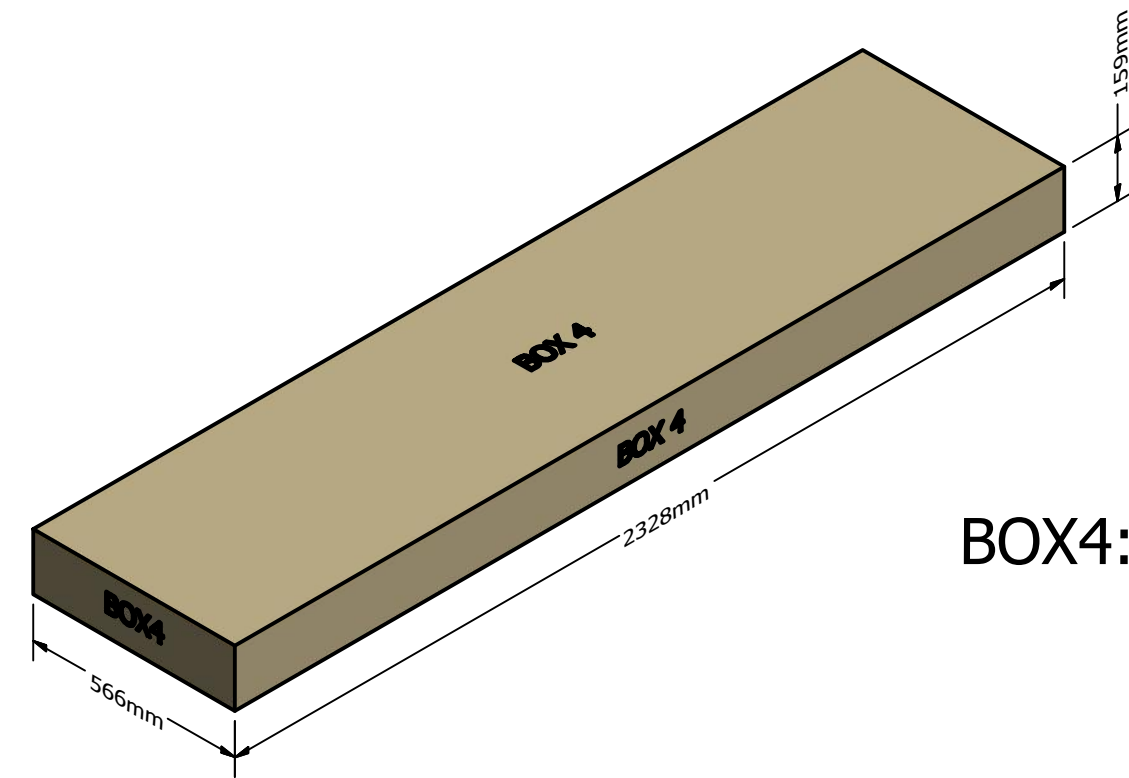

BOX4: 67kg

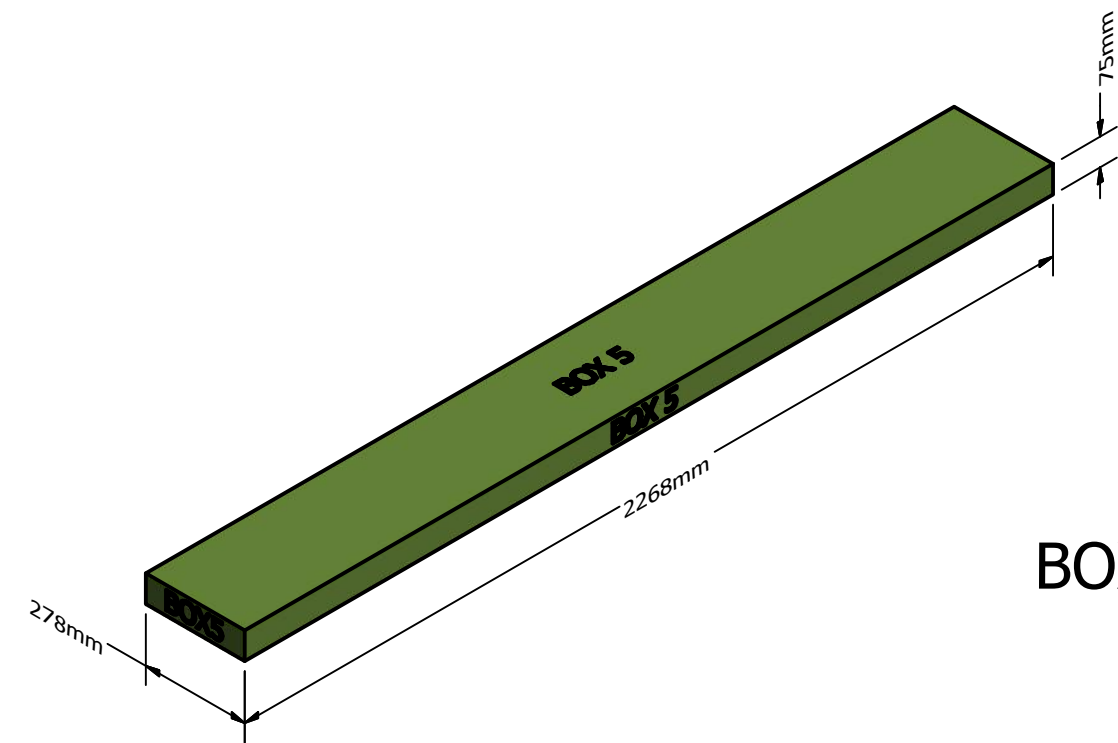

BOX5: 20kg

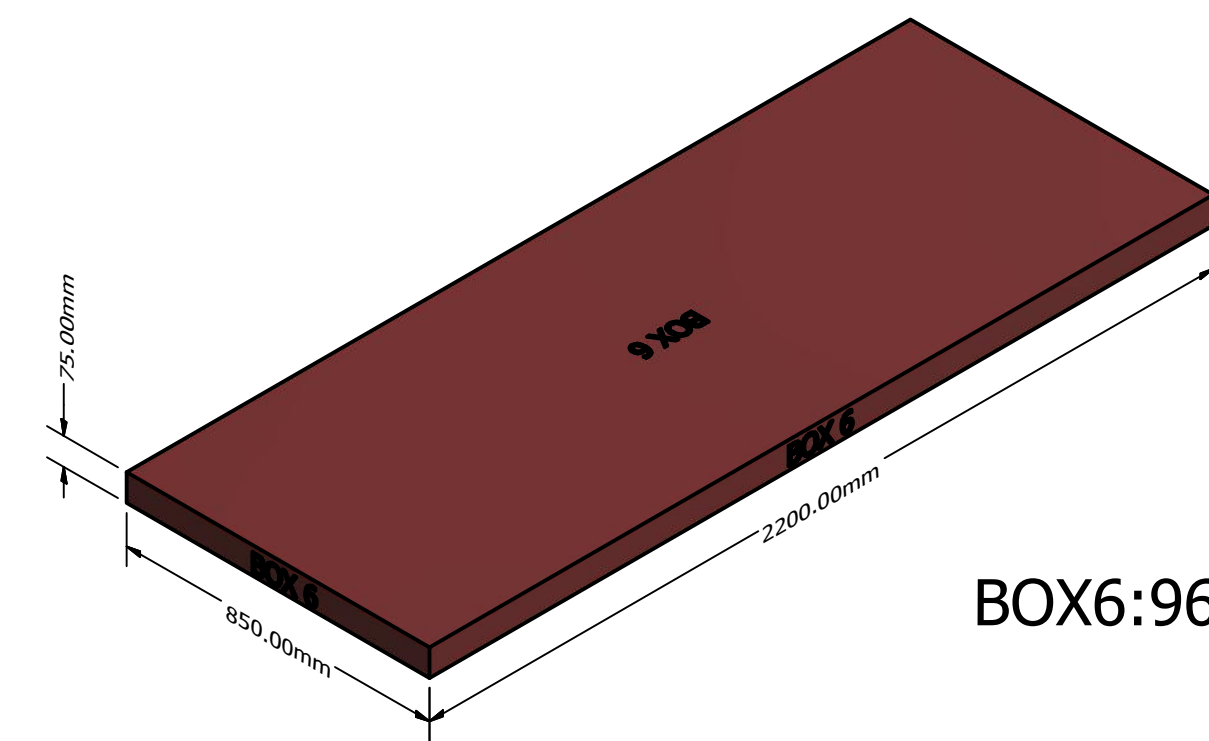

BOX6: 96kg

| | | | |
|---------------|-----------|-----------------|-------------------------|
| DRAWN Rudy | 2019/8/19 | | |
| CHECKED | | TITLE | |
| QA | | | |
| MFG | | | |
| APPROVED | | | |
| | | SIZE D | DWG NO Pallet A (详细) |
| | | SCALE 1 / 15 | REV |
| | | SHEET 1 OF 1 | |