

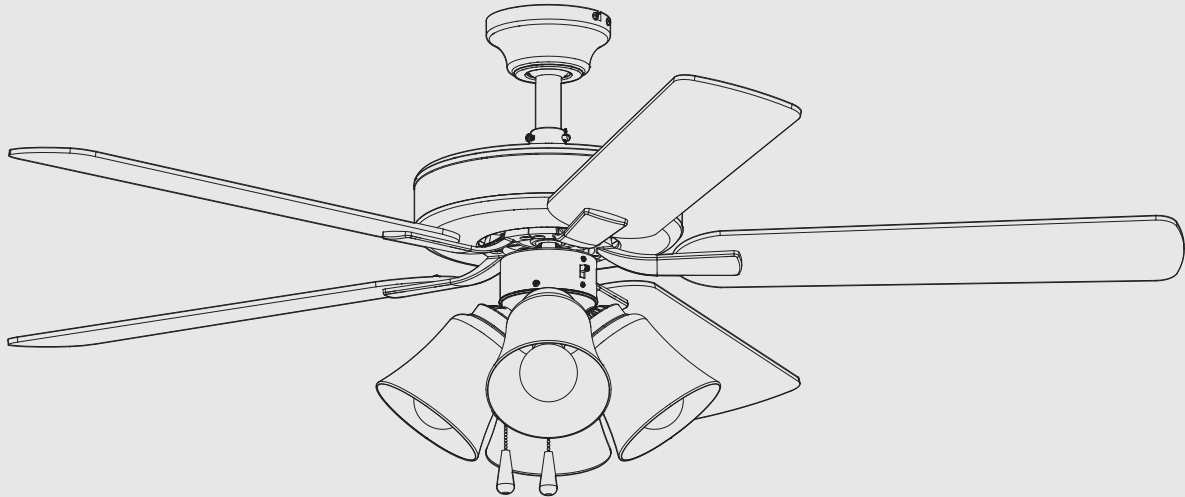

Ceiling Fan Installation Manual



30-Year Limited Warranty

Progress Lighting fan motors are warranted to the END USER to be free of electrical and/or mechanical defects for a period of 30 (thirty) years from date of sale. Pull chain switches, reverse switches, capacitors and metal finishes are warranted for a period of 1 year. Warping of wooden or plastic blades is not covered by this warranty.

The END USER has the option of returning the defective fan to the place of purchase during the first 30 days for a replacement. After 30 days, the purchaser MUST contact Progress Lighting for repair or replacement. The END USER also bears the responsibility for all costs in the removal, shipping and reinstallation of fans or parts for repair or replacement.

Progress Lighting will not assume liability or responsibility for damages (including incidental or consequential) caused by improper installation or operation of the unit or its component parts, or by the failure of supporting hardware not supplied by Progress Lighting. This warranty is given in lieu of all other guarantees, whether expressed or implied, and is voided in cases of abuse, misuse or improper handling, negligence, shipping damage, unauthorized repairs (made or attempted) or unusual application.

Some states do not allow limitations on how long an implied warranty lasts or the exclusion or limitations of incidental or consequential damages, so the above limitations and exclusions may not apply to you. This warranty gives you specific rights and you may have other rights which vary from state to state.

Date Purchased _____

Store Purchased _____

Model No. P250085

Serial No. _____

Vendor No. 111017

UPC 785247264384

785247264391

785247264407



Safety Rules	1
Unpacking Your Fan	2
Installing Your Fan	3
Operating Your Fan	9
Care of Your Fan	10
Troubleshooting	10
Specifications	11

Table of Contents

READ AND SAVE THESE INSTRUCTIONS

1. To reduce the risk of electric shock, insure electricity has been turned off at the circuit breaker or fuse box before beginning.
2. All wiring must be in accordance with the National Electrical Code ANSI/NFPA 70-1999 and local electrical codes. Electrical installation should be performed by a qualified licensed electrician.
3. **CAUTION:** To reduce the risk of personal injury, use only the screws provided with the electrical box.
4. The outlet box and support structure must be securely mounted and capable of reliably supporting 35 lbs. (15.9 kg). Use only UL Listed outlet boxes marked “Acceptable for Fan Support of 35 lbs. (15.9 kg) or less.”
5. The fan must be mounted with a **minimum of 7 feet clearance** from the trailing edge of the blades to the floor.
6. Do not operate reversing switch while fan blades are in motion. Fan must be turned off and blades stopped before reversing blade direction.
7. Avoid placing objects in path of the blades.
8. To avoid personal injury or damage to the fan and other items, be cautious when working around or cleaning the fan.
9. Do not use water or detergents when cleaning the fan or fan blades. A dry dust cloth or lightly dampened cloth will be suitable for most cleaning.
10. After making electrical connections, spliced conductors should be turned upward and pushed carefully up into electrical box. The wires should be spread apart with the grounded conductor and the equipment-grounding conductor on one side of the electrical box and ungrounded conductor on the other side of the electrical box.
11. Electrical diagrams are for reference only. Light kits that are not packed with the fan must be UL Listed and marked suitable for use with the model fan you are installing. Switches must be UL General Use Switches. Refer to the instructions packaged with the light kits and switches for proper assembly.
12. All set screws must be checked and retightened where necessary before installation.

WARNING

TO REDUCE THE RISK OF FIRE, ELECTRIC SHOCK OR PERSONAL INJURY, MOUNT TO OUTLET BOX MARKED “ACCEPTABLE FOR FAN SUPPORT OF 35LBS. (15.9 KG) OR LESS”, AND USE SCREWS PROVIDED WITH THE OUTLET BOX.

WARNING

TO REDUCE THE RISK OF PERSONAL INJURY, DO NOT BEND THE BLADE BRACKETS (ALSO REFERRED TO AS (“FLANGES”)) DURING ASSEMBLY OR AFTER INSTALLATION. DO NOT INSERT OBJECTS IN THE PATH OF THE BLADES.

WARNING

TO REDUCE THE RISK OF SHOCK, THIS FAN MUST BE INSTALLED WITH AN ISOLATION WALL CONTROL/SWITCH.

1. Safety Rules

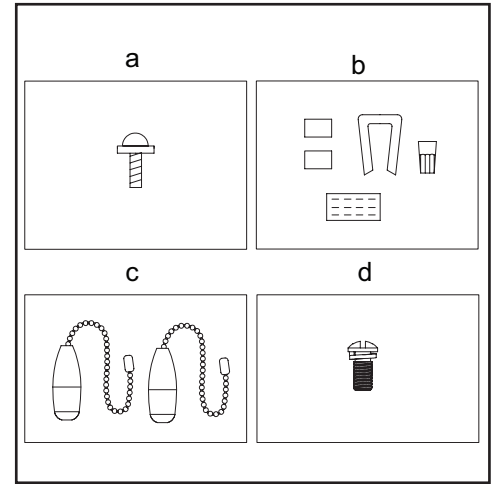
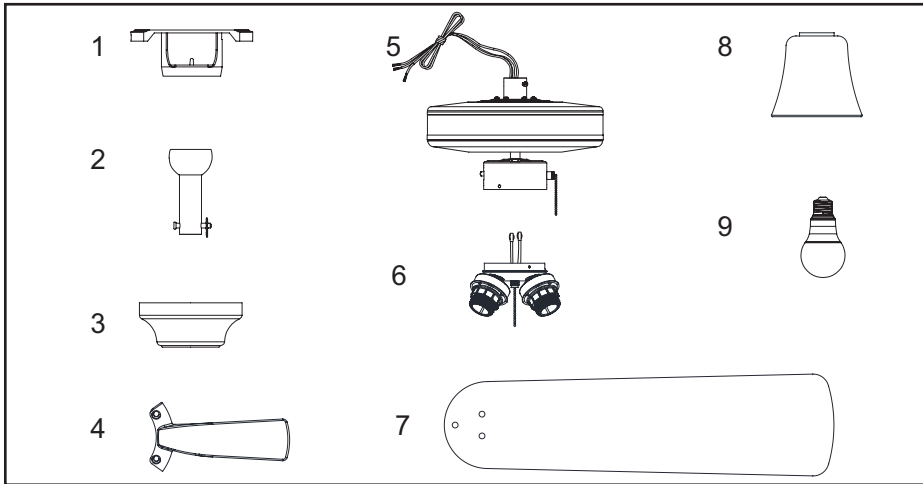

Unpack your fan and check the contents. You should have the following items:

- | | | |
|--|-----------------------|--|
| 1. Mounting Bracket (inside canopy) | 5. Fan Motor Assembly | a. Mounting hardware
(16 blade attachment screws) |
| 2. 4.25" Ball/Downrod Assembly (hanger pin and locking pin pre-attached) | 6. Light Kit | b. Electrical hardware & Balancing kit (3 plastic wire connectors, blade balancing kit) |
| 3. Canopy | 7. Blades (5) | c. Pull chain (2) |
| 4. Blade Arms (5) | 8. Glass Shades (4) | d. Extra blade bracket screw |
| | 9. Bulbs (4) | |

2. Unpacking Your Fan

Tools Required

Phillips screw driver or straight slotted screw driver, adjustable wrench, step ladder, and wire cutters.



Mounting Options

If there isn't an existing electrical box, then read the following instructions. **Disconnect the power by removing fuses or turning off circuit breakers.**

Secure the electrical box directly to the building structure. Use appropriate fasteners and building materials. The electrical box and its support must be able to fully support the moving weight of the fan (at least 35 lbs.). **Do not use plastic electrical boxes.**

WARNING

TO REDUCE THE RISK OF FIRE, ELECTRIC SHOCK OR PERSONAL INJURY, MOUNT TO OUTLET BOX MARKED "ACCEPTABLE FOR FAN SUPPORT OF 35LBS. (15.9 KG) OR LESS", AND USE SCREWS PROVIDED WITH THE OUTLET BOX. ELECTRICAL BOXES COMMONLY USED FOR THE SUPPORT OF LIGHTING FIXTURES MAY NOT BE ACCEPTABLE FOR FAN SUPPORT AND MAY NEED TO BE REPLACED. CONSULT A QUALIFIED ELECTRICIAN IF IN DOUBT.

Figures 1, 2, and 3 are examples of different ways to mount the electrical box.

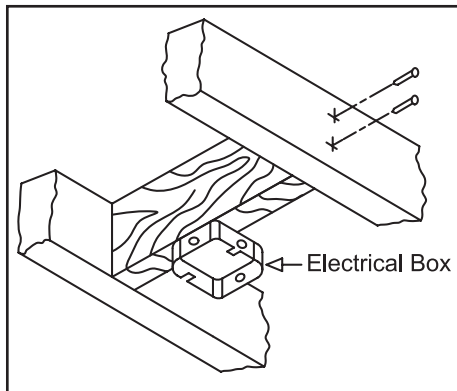

Figure 1

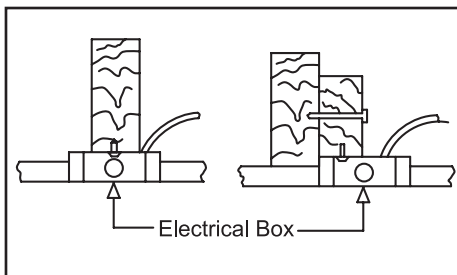

Figure 2

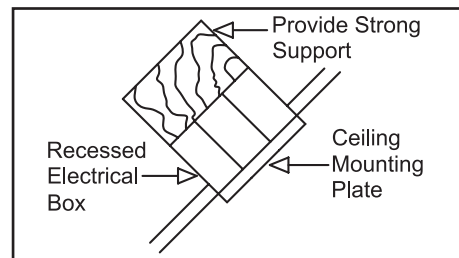

Figure 3

Note: You may need a longer downrod to maintain proper blade clearance when installing on a steep, sloped ceiling. **The maximum angle allowable is 30°.** If the canopy touches downrod, remove the decorative canopy bottom cover and turn the canopy 180° before attaching the canopy to the mounting bracket.

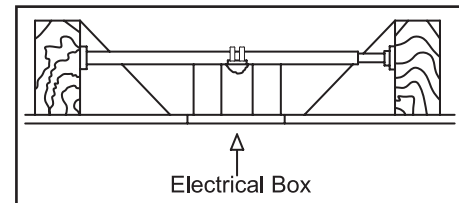

Figure 4

To hang your fan where there is an existing fixture but no ceiling joist, you may need an installation hanger bar as shown in Figure 4.

3. Installing Your Fan

Hanging the Fan

REMEMBER to turn off the power. Follow the steps below to hang your fan properly.

NOTE: This fan is recommended for standard ceiling mount using the downrod provided with this fan. When using standard ceiling installation with the 4.25 inch downrod provided, the distance from the ceiling to the bottom of the fan blades will be approximately 10.4 inches.

Standard Ceiling Mounting

1. Remove the mounting bracket from the canopy by loosening the four screws on the top of the canopy. Remove the two non-slotted screws and loosen the slotted screws. This will enable you to remove the mounting bracket. (Figure 5)
2. Remove the hanger pin and locking pin from downrod assembly.
3. Make sure the slot openings are on top. Route the wires through the canopy and then through the ball/downrod assembly. (Figure 6)
4. Loosen, but do not remove, the set screws on the collar on the top of the motor housing.

5. Align the holes at the bottom of the downrod with the holes in the collar on top of the motor housing. (Figure 6)
Carefully insert the hanger pin through the holes in the collar and downrod. Be careful not to jam the hanger pin against the wiring inside the downrod. Insert the locking pin through the hole near the end of the bolt until it snaps into its locked position, as noted in the circle inset of Figure 6.
6. Re-tighten the set screws on the collar on top of the motor housing.
7. Make sure that the canopy is oriented correctly.
8. Proceed to “Installing the Fan” section.

WARNING

FAILURE TO PROPERLY INSTALL SET SCREWS AS NOTED IN STEP 6 COULD RESULT IN FAN LOOSENING AND POSSIBLY FALLING.

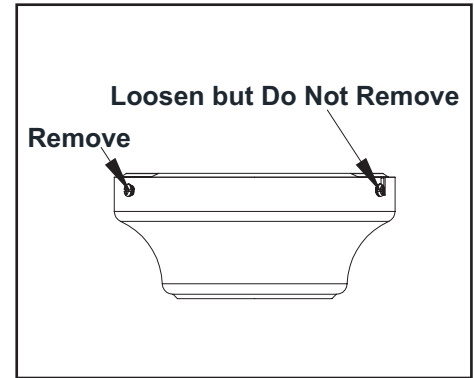

Figure 5

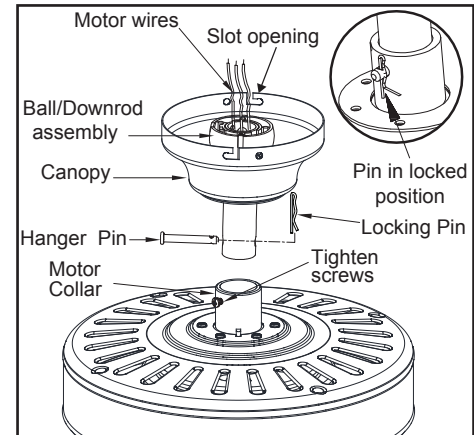

Figure 6

Installing Fan to the Electrical Box

CAUTION

WHEN MOUNTING THE FAN ON A SLOPED CEILING, THE STANDARD BALL/DOWNROD MOUNTING METHOD MUST BE USED. THE MOUNTING BRACKET MUST BE MOUNTED SO THAT THE SLOT OPENINGS ARE ON THE LOWER SIDE BY SLIDING THE MOUNTING BRACKET FROM THE TOP DOWN.

1. Pass the 120-volt supply wires through the center hole in the ceiling mounting bracket as shown in Figure 7.
2. Install the ceiling mounting bracket on the electrical box by using the mounting screws provided with the electrical box. Note that the flat side of the mounting bracket is toward the electrical box. (Figure 7)
3. Tighten the two screws on the electrical box securely.
4. Carefully lift the fan assembly up to the ceiling mounting bracket. Make sure the tab on the mounting bracket is properly seated in the groove in the hanger ball. (Figure 8)

WARNING

WHEN USING THE STANDARD BALL/DOWNROD MOUNTING, THE TAB IN THE RING AT THE BOTTOM OF THE MOUNTING BRACKET MUST REST IN THE GROOVE OF THE HANGER BALL. FAILURE TO PROPERLY SEAT THE TAB IN THE GROOVE COULD CAUSE DAMAGE TO WIRING.

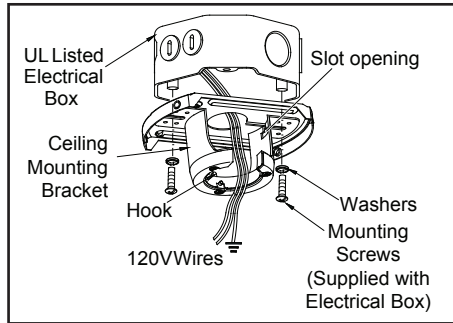

Figure 7

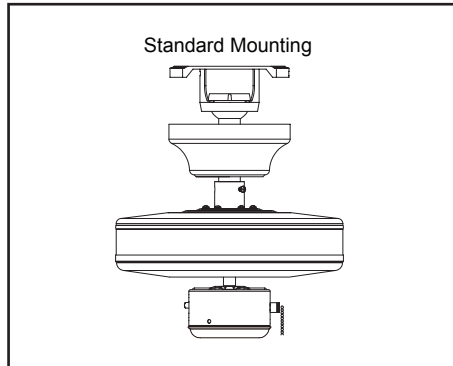

Figure 8

Making the Electrical Connections

REMEMBER to disconnect the power. If you feel you do not have enough electrical wiring knowledge or experience, have your fan installed by a licensed electrician.

Follow the steps below to connect the fan to your household wiring. Use the wire connecting nuts supplied with your fan. Secure the connectors with electrical tape. Make sure there are no loose strands or connections. (Figure 9)

1. Connect the two green fan ground wires, located on the downrod and mounting bracket, to the household ground wire.
2. Connect the neutral fan (white) wire to the white neutral household wire.
3. Connect the fan supply (black and blue) wire to the black household supply wire as shown in figure 9.
4. After connecting the wires, spread them apart so that the green and white wires are on one side of the outlet box and the black wire is on the other side.
5. Turn the wire connecting nuts upward and push the wiring into the outlet box.

NOTE

USE THE WIRE CONNECTORS SUPPLIED WITH YOUR FAN. SECURE THE CONNECTORS WITH ELECTRICAL TAPE AND ENSURE THERE ARE NO LOOSE STRANDS OR CONNECTIONS

WARNING

EACH WIRE NUT (WIRE CONNECTOR) SUPPLIED WITH THIS FAN IS DESIGNED TO ACCEPT UP TO ONE 12 GAUGE HOUSE WIRE AND TWO WIRES FROM THIS FAN. IF YOU HAVE LARGER THAN 12 GAUGE HOUSE WIRING OR MORE THAN ONE HOUSE WIRE TO CONNECT TO THE FAN WIRING, CONSULT AN ELECTRICIAN FOR THE PROPER SIZE WIRE NUTS TO USE.

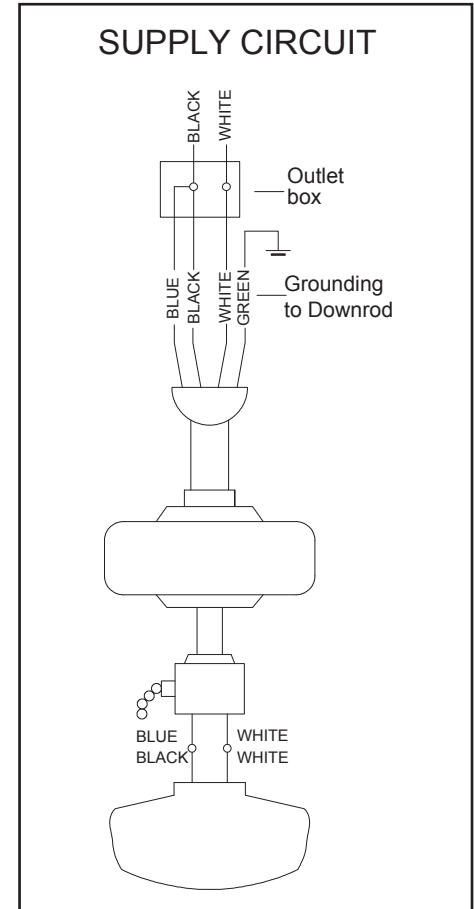

Figure 9

Finishing the Fan Installation

STANDARD CEILING MOUNTING

WARNING

WHEN USING THE STANDARD BALL/DOWNROD MOUNTING, THE TAB IN THE RING AT THE BOTTOM OF THE MOUNTING PLATE MUST REST IN THE GROOVE OF THE HANGER BALL. FAILURE TO PROPERLY SEAT THE TAB IN THE GROOVE COULD CAUSE DAMAGE TO WIRING.

1. Align the locking slots of the ceiling canopy with the two screws in the mounting bracket. Push up to engage the slots and turn clockwise to lock in place. Immediately tighten the two mounting screws firmly.
2. Install the remaining two mounting screws into the holes in the canopy and tighten firmly.
3. You may now proceed to attaching the fan blades.

Attaching the Fan Blades

NOTE: Your fan blades are reversible. Select the blade finish which best accentuates your decor.

1. Attach blade to blade bracket using screws shown in Figure 10. Repeat for the two remaining screws.
2. Tighten each screw securely.

3. Fasten the blade assembly to the motor by aligning the screw holes on the bottom of the fan motor with the holes on the blade arm, and tightening the motor screws. Please note that the motor screws are preattached into the blade brackets. (Figure 11)
4. Repeat steps 1,2 & 3 for the remaining blades.

Blade Balancing

All blades are grouped by weight. Because natural woods vary in density, the fan may wobble even though the blades are weight matched.

The following procedure should correct most fan wobble. Check after each step.

1. Check that all blade screws are secure.
2. Most fan wobble problems are caused when blade levels are unequal. Check this level by selecting a point on the ceiling above the tip of one of the blades. Measure from a point on the center of each blade to the point on the ceiling. Measure this distance as shown in Figure 12. Rotate the fan until the next blade is positioned for measurement. Repeat for each blade. Measurements deviation should be within 1/8". Run the fan for 10 minutes.
3. Make sure that canopy is tightened securely to ceiling mounting bracket and that the ceiling mounting bracket is tightened securely to the electrical box.
4. Interchanging two adjacent blades can redistribute the weight and possibly result in the smoother operation.
5. Use the enclosed Blade Balancing Kit if the blade wobble is still noticeable.

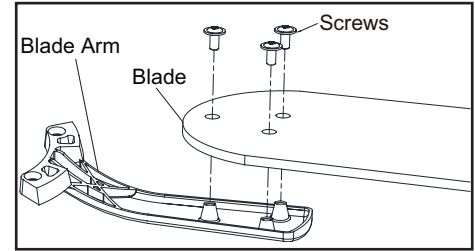

Figure 10

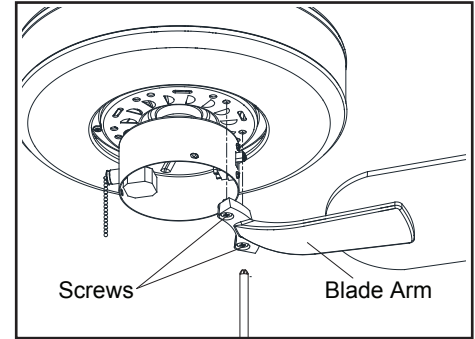

Figure 11

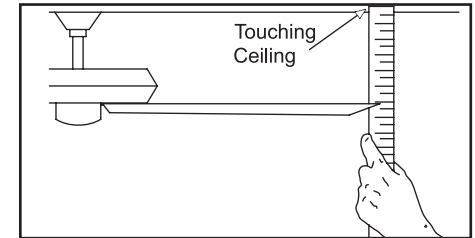

Figure 12

Installing the Light Kit

WARNING

TO REDUCE THE RISK OF ELECTRIC SHOCK, DISCONNECT THE ELECTRICAL SUPPLY CIRCUIT TO THE FAN BEFORE INSTALLING THE LIGHT FIXTURE.

1. Remove the three screws on the switch cup cover of the light kit fitter assembly.
2. Connect the wires from the light kit fitter assembly to the wires from the switch cup of the fan-motor assembly by connecting the molded adaptor plugs together (blue to black, white to white). Carefully tuck all wires and splices into the switch cup.
3. Align the three holes in the switch cup cover of the light kit fitter assembly with the three holes in the switch cup of the fan-motor assembly. Make sure the notch in the switch cup cover of the light kit fitter assembly clears the reversing switch in the switch cup of the fan-motor assembly. Position the light kit fitter assembly and re-install the three screws that were removed in first step to secure the light kit fitter assembly. (Figure 12)
4. Remove the compressing ring from the threaded socket of the light kit by turning the compressing ring counter-clockwise until it unlocks.
5. Insert the glass shade into the light kit assembly and turn the compressing ring clockwise to tighten and secure the glass shade. Repeat for the remaining shades. (Figure 13)
6. With power off, screw the LED bulbs (8.5W, provided) into the sockets. (Figure 14)
7. Attach the pull chain extensions provided to the light pull chain and fan pull chain. (Figure 15)

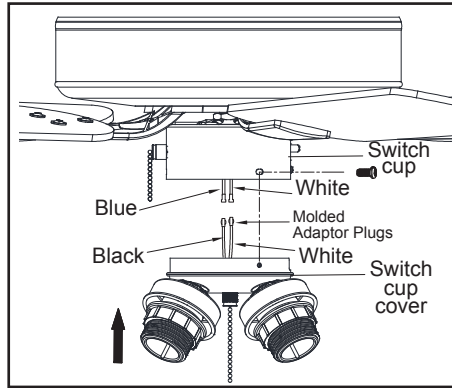

Figure 13

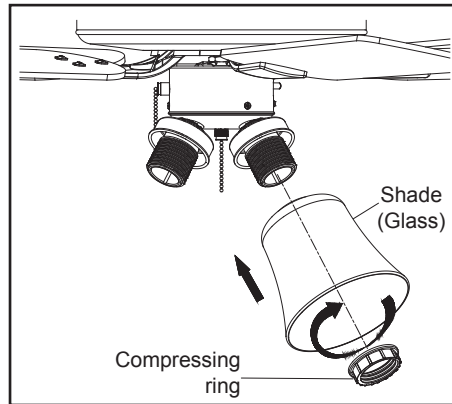

Figure 14

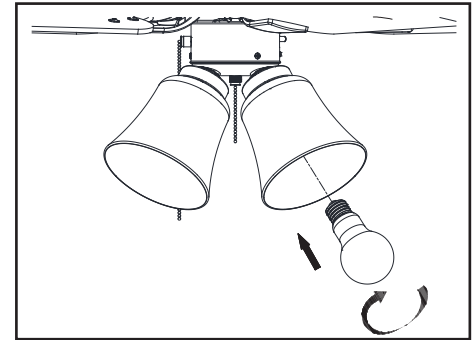

Figure 15

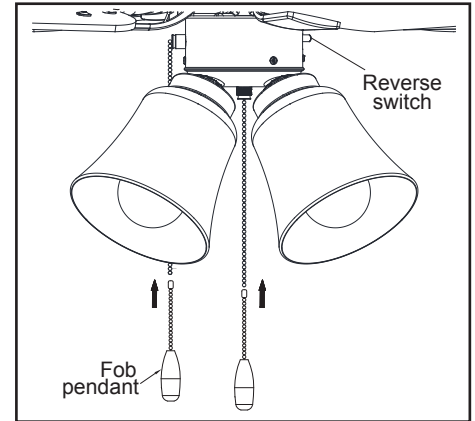

Figure 16

Speed settings for warm or cool weather depend on factors such as room size, ceiling height, number of fans, and so on.

The fan shipped from the factory with the reverse switch positioned to circulate air downward. If airflow is desired in the opposite direction, turn your fan off and wait for the blades to stop turning, then slide the reverse switch (located on the switch housing, refer to figure 16) to opposite position, and turn fan on again. The fan blades will turn in the opposite direction and reverse airflow.

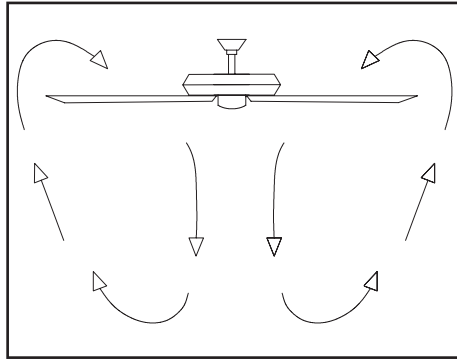

Figure 17

Warm weather - (Forward) A downward air flow creates a cooling effect as shown in Figure 17. This allows you to set your air conditioner on a higher setting without affecting your comfort.

Cool weather - (Reverse) An upward air flow moves warm air off the ceiling as shown in Figure 18. This allows you to set your heating unit on a lower setting without affecting your comfort.

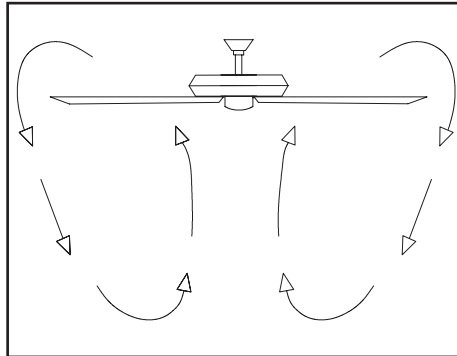

Figure 18

9. Operating Your Fan

Care of Your Fan

Here are some suggestions to help you maintain your fan.

1. Because of the fan's natural movement, some connections may become loose.
Check the support connections, brackets, and blade attachments twice a year. Make sure they are secure. **(It is not necessary to remove fan from ceiling.)**
2. Clean your fan periodically to help maintain its new appearance over the years. Do not use water when cleaning, this could damage the motor, or the wood or possibly cause an electrical shock. Use only a soft brush or lint-free cloth to avoid scratching the finish. The plating is sealed with a lacquer to minimize discoloration or tarnishing.
Warning - Make sure the power is off before cleaning your fan.
3. You can apply a light coat of furniture polish to the wood for additional protection and enhanced beauty. Cover small scratches with a light application of shoe polish.
4. **There is no need to oil your fan.**
The motor has permanently lubricated sealed ball bearings.

Troubleshooting

Problem

Solution

Fan will not start

1. Check main and branch circuit fuses or breakers
2. Check line wire connections to the fan and switch wire connections in the switch housing. **CAUTION: Make sure main power is off.**

Fan sounds noisy

1. Make sure all motor housing screws are snug.
2. Make sure the screws that attach the fan blade bracket to the motor hub are tight.
3. Make sure wire nut connections are not rattling against each other or the interior wall of the switch housing.
CAUTION: Make sure power is off.
4. Allow a 24-hour "breaking in" period. Most noises associated with a new fan disappear during this time.
5. If using the Ceiling Fan light kit, make sure the screws securing the glassware are tight. Check that the light bulb is also secure.
6. Make sure the canopy is a short distance from the ceiling.
It should not touch the ceiling.
7. Make sure your electrical box is secure and rubber isolator pads were used between the mounting bracket and electrical box.

WARNING

MAKE SURE THE POWER IS OFF AT THE ELECTRICAL PANEL BOX BEFORE YOU ATTEMPT TO MAKE ANY REPAIRS. REFER TO THE SECTION, "MAKING ELECTRICAL CONNECTIONS."

10. Care of Your Fan and Troubleshooting

FAN SIZE	SPEED	VOLTS	FAN POWER CONSUMPTION (WITHOUT LIGHTS) WATTS	AIRFLOW CFM	AIRFLOW EFFICIENCY (HIGHER IS BETTER) CFM/WATT	NET WEIGHT	GROSS WEIGHT	CUBE FEET
52"	Low	120	10.62	1905	179.3	17.42	20.73	2.28
	High	120	58.14	4587	78.9	Lbs	Lbs	

©2016 Progress Lighting, Inc.
701 Millennium Blvd.,
Greenville, SC 29607
All Rights Reserved

11. Specifications