

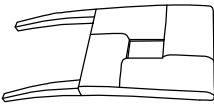

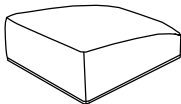





ASSEMBLY INSTRUCTION

SIDE CHAIR

A Chair Back 1pc 	B Seat 1pc 	C Front Leg 2pcs 	D Lock Washer Ø5/16"x13mm 8pcs 
E Flat Washer Ø5/16"x19mm 8pcs 	F Bolt Ø5/16"x3" 4pcs 	G Bolt Ø5/16"x2-1/2" 4pcs 	H Allen Key M5 1pc 
I Wood Dowel Ø10x30mm 1pc 			

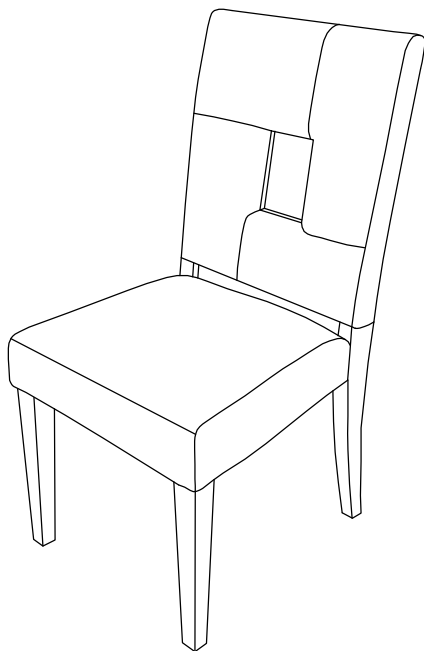

This page lists all the contents included in the box. Please take the time to identify the hardware as well as the individual components to this product. As you unpack and prepare for assembly, place the contents on a carpeted or padded area to protect them from damage.

- Put the Seat (B) on a smooth flat surface, attach Front Leg (C) to the Seat (B) using Bolt (G), Lock Washer (D) and Flat Washer (E) on both holes of Seat (B) by Allen Key (H). Turn the Allen Key (H) in Bolt (G). But not too tight. Attach Wood Dowel (I) to Seat (B) back.

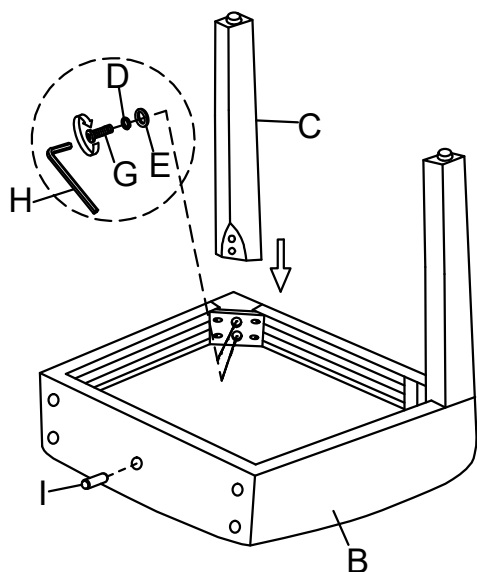

Take the Allen Key, and turn the bolts until the legs are secure.
DO NOT TIGHTEN COMPLETELY.
 Stop when you feel you are adding force to tighten the bolt.

- Put Chair Back (A) on a smooth flat surface, attach the Seat (B) to the Chair Back (A) using Bolt (F), Lock Washer (D), Flat Washer (E) in both holes of Seat (B) and Chair Back (A). Turn the Allen Key (H) in Bolt (F).

Stand chair up on an even surface and check that it is balanced. If there is a slight wobble, apply downward pressure in the corner where a leg is uneven. Keeping pressure in that corner, tighten all bolts. If balanced, apply downward pressure evenly in the center and tighten all bolts. Do not over-tighten beyond hole depth.

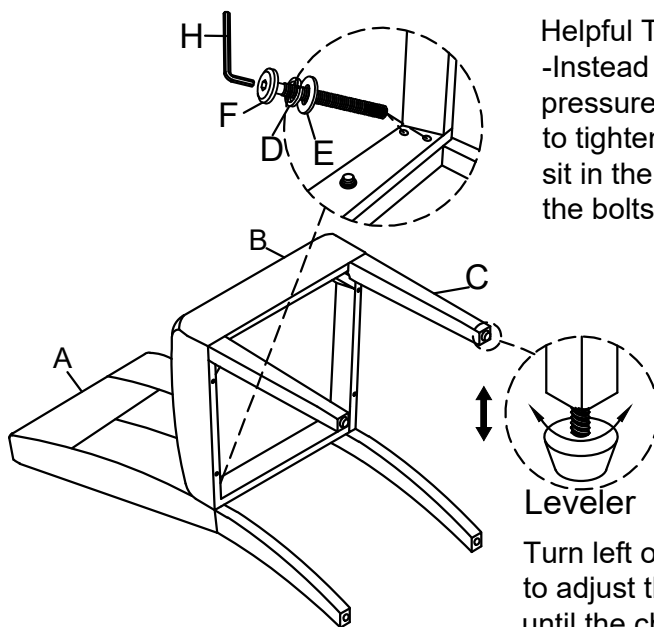

Helpful Tip:
 -Instead of applying downward pressure while reaching under to tighten bolts, have someone sit in the chair while you tighten the bolts.

Leveler
 Turn left or turn right to adjust the leveler until the chair is stabilized.

Cleaning & Care

Treat surface with care. Surface is resistant to scratches but is not scratch resistant. Clean surfaces with a dry or damp soft cloth. Do not use abrasive cleaners. Hardware may loosen over time. Periodically check that all connections are tight.