









ASSEMBLY INSTRUCTION

E612C TUFTED DINING CHAIR

A SEAT  1PC	B FRONT LEG  2PCS	C BACK LEG  2PCS	D LOCK WASHER 5/16"  8PCS
E FLAT WASHER 5/16"  8PCS	F BOLT 5/16"x2-3/8"  4PCS	G BOLT 5/16"x1-3/4"  4PCS	H ALLEN KEY 5/16"  1PC

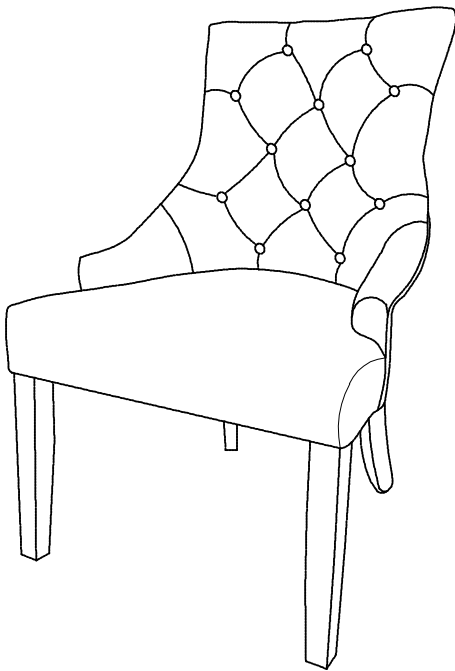

This page lists all the contents included in the box. Please take the time to identify the hardware as well as the individual components to this product. As you unpack and prepare for assembly, place the contents on a carpeted or padded area to protect them from damage.

- 1** Attach the Front legs(B) to Seat(A) with Lock washer(D) and Flat washer(E) and Bolt(F) by Allen key(H).

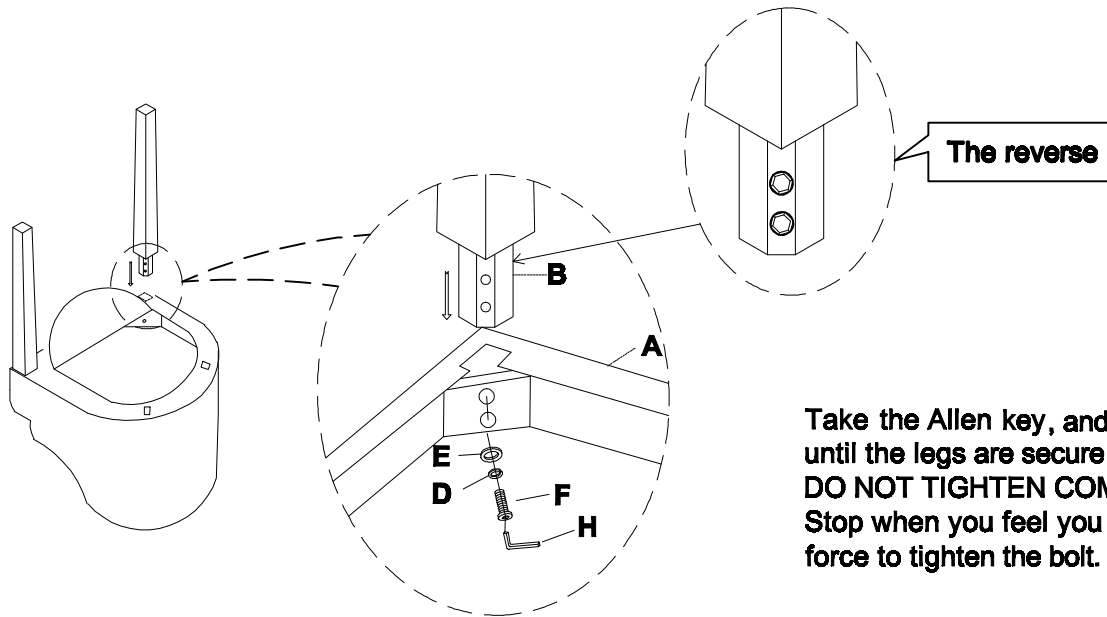

Take the Allen key, and turn the bolts until the legs are secure. **DO NOT TIGHTEN COMPLETELY.** Stop when you feel you are adding force to tighten the bolt.

- 2** Attach the Back legs(C) to Seat(A) with Lock washer(D) and Flat washer(E) and Bolt(G) by Allen key(H).

Stand chair up on an even surface and check that it is balanced. If there is a slight wobble, apply downward pressure in the corner where a leg is uneven. Keeping pressure in that corner, tighten all bolts. If balanced, apply downward pressure evenly in the center and tighten all bolts. Do not over-tighten beyond hole depth.

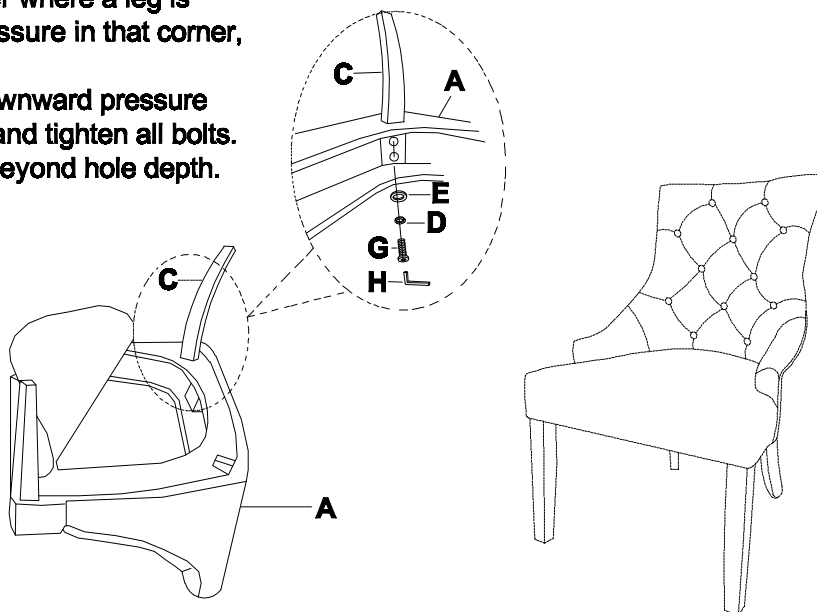

Helpful Tip:
-Instead of applying downward pressure while reaching under to tighten bolts, have someone sit in the chair while you tighten the bolts.

Cleaning & Care

Treat surface with care. Surface is resistant to scratches but is not scratch resistant. Clean surfaces with a dry or damp soft cloth. Do not use abrasive cleaners. Hardware may loosen over time. Periodically check that all connections are tight.