

SILVERBACK

60" INGROUND BASKETBALL SYSTEM

MODEL NO.
B8409



**Please Do Not Return This
Product to the Store!**

Contact Escalade® Sports customer service department at:
Phone: 1-888-USA-GOAL Toll-Free!
Fax: 1-866-873-3536 Toll-Free!
E-mail: customerservice@escaladesports.com

ESCALADE®
SPORTS

Escalade® Sports products may be manufactured and/or licensed under the following patents.
6120397, 5816957, 5769744, 5119741, 4911085, 4717157, D460140, D420563, 8414431
Additional patents may be pending. One or more of the listed patents and/or pending patents may cover specific product.

2L-7989-01

2022 Escalade® Sports

PRE-ASSEMBLY TIPS

- 1. Read this manual carefully before starting assembly.** Read each step completely before beginning each step.
- 2. Some smaller parts may be shipped inside larger parts. Check inside all parts and cartons before assembling or ordering parts.**
- 3. To make assembly easier, use the Hardware Identifier on page 8 to identify and sort all fasteners. Check all cartons for kits. All hardware may not be located in one kit.**
- 4. Do not tighten hardware until instructed to do so. If hardware is tightened too soon, mounting holes may not align and parts may not easily fit together. Leave locknuts slightly loose until you are instructed to tighten them.**
- 5. Save these instructions and your proof of purchase (receipt) in the event that the manufacturer has to be contacted for replacement parts.**

Tools required for assembly:

- 2 Capable Adults
- 50 lbs bags of concrete (x9 approximately)
- Wheel barrow
- Garden Hose/Water source
- Carpenters Level
- Pencil or other marking tool
- Masking tape
- 15ft (minimum) Tape Measure
- Step Ladder 8ft minimum (x2)
- 2 each Wrenches and/or Socket Wrenches and Sockets(deep-well sockets are recommended) (extension recommended) 13mm, 16mm, 17mm, 19mm
- 3/8" X 48" wood dowel
- Phillips Screw Driver
- Heavy Grease
- String (about 4' long)
- Cordless Drill
- 5/16" Driver (for cordless drill)

Optional Items

- 2 Medium Size Adjustable Wrenches
- 5 gal. bucket
- Hex Key socket



Please Do Not Return This Product To The Store!

Contact Escalade® Sports customer service department at:

Phone: 1-800-USA-GOAL Toll – Free !

Fax: 1-866-873-3536 Toll – Free !

E-mail: basketball@escaladesports.com

Escalade Sports

Physical Location:

817 Maxwell Ave.
Evansville, IN 47711

Mailing Address: (Correspondence Only)

PO Box 889
Evansville, IN 47706

Please visit our Website at:
www.escaladesports.com

ON-LINE TROUBLE SHOOTING TECHNICAL ASSISTANCE
ON-LINE PARTS REQUESTS FREQUENTLY ASKED QUESTIONS
ADDITIONAL ESCALADE® SPORTS PRODUCT INFORMATION



WARNING

FAILURE TO FOLLOW THESE WARNINGS MAY RESULT IN SERIOUS INJURY AND/OR PROPERTY DAMAGE.

Owner must ensure that all players know and follow these rules for safe operation of the system.

- DO NOT DUNK on this system.
- DO NOT HANG on the rim or any part of system including backboard, support braces or net.
- During play, keep players face away from the backboard, rim, and net. Serious injury could occur if teeth/face encounter backboard, rim, or net.
- Wear a mouthguard when playing to avoid dental injuries.
- Do not slide, climb, or play on pole.
- During Play, do not wear jewelry (rings, watches, necklaces, etc.). Objects may entangle in net or other areas of structure.
- Do not allow children to adjust system.
- When adjusting height, keep hands and fingers away from moving parts.
- Keep water and organic material away from pole. Pole can rust and fail.
- Check system BEFORE EACH USE for loose hardware, instability and signs of corrosion and repair before each use. Never play on damaged equipment.
- Once a month check pole and all metal parts for rust. Completely remove rust and repaint with exterior enamel. If rust has penetrated any steel part, replace that part immediately.
- Do not use this system to lift or hoist anything. The mechanism is designed to lift only the weight of the backboard and rim. Do not hang anything from the handle, rim, backboard, or lifter arms as this will damage the system and void the warranty.
- Refer to product manual for assembly instructions.

4L-7609-01

www.escaladesports.com

1-888-USA-GOAL

SAFETY INSTRUCTIONS

FAILURE TO FOLLOW THESE SAFETY INSTRUCTIONS MAY RESULT IN SERIOUS INJURY, PROPERTY DAMAGE AND WILL VOID WARRANTY.

Owner must ensure that all players know and follow these rules for safe operation of the system.

To ensure safety, do not attempt to assemble this system without following the instructions carefully. Proper and complete assembly, use and supervision is essential for proper operation and to reduce the risk of accident or injury. A high probability of serious injury exists if this system is not installed, maintained, and operated properly.

- If using a ladder during assembly, use extreme caution.
- 2 people are recommended for this operation.
- Seat the pole sections properly (if applicable). Failure to do so could allow the pole sections to separate during play.
- Before digging contact utility company to locate underground power cables, gas and water lines. Ensure there are no overhead power lines within 20 ft. (7m) radius of pole location.
- Climate, corrosion or misuse could result in system failure.
- If technical assistance is required, contact the manufacturer.
- Minimum operational height is 6'6" (1.98m) to the bottom of backboard.

*Most injuries are caused by misuse and/or not following instructions.
Use caution when using this system.*

WARNING

FAILURE TO FOLLOW THESE WARNINGS MAY RESULT IN SERIOUS INJURY AND/OR PROPERTY DAMAGE.

- DO NOT DUNK on this system.
- During play, do not wear jewelry (rings, watches, necklaces, etc.) Objects may entangle in net or other areas of structure.
- Wear mouth guard during playing to avoid dental injuries.
- Do not allow children to adjust the system.
- See pole for additional warnings.



WARNING

**DO NOT DUNK ON THIS UNIT .
DO NOT HANG FROM ANY PART OF THIS
UNIT , INCLUDING THE BACKBOARD, RIM,
SUPPORT BRACES OR NET.**

4L-8152-00

PARTS LIST (NOT ACTUAL SIZE)

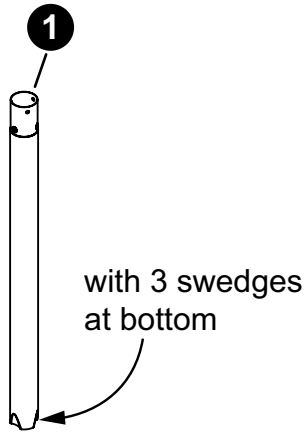

LOWER POLE
1A-7946-20
QTY. 1



TUBE, REINFORCEMENT
8S-8246-00
QTY. 1

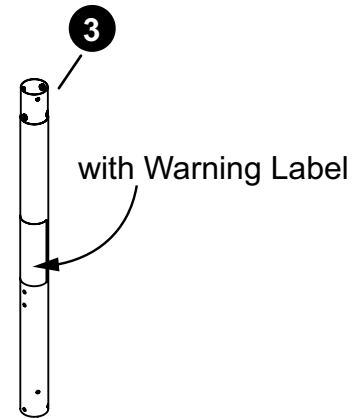

MIDDLE POLE
1A-7947-20
QTY. 1

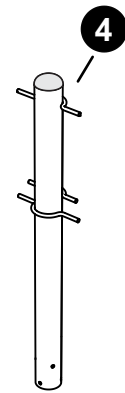

TOP POLE
1A-7948-20
QTY. 1

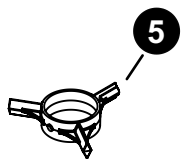

SPACER FOR REINFORCEMENT TUBE
3M-9060-00
QTY. 2



REINFORCEMENT PLATE
8S-7711-20
QTY. 1

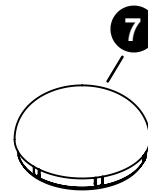

POLE CAP
3M-8997-00
QTY. 1
(Pre-assembled
to part #4)

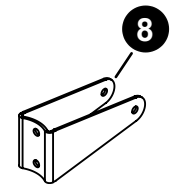

ACTUATOR BRACKET
2S-9425-20
QTY. 1

PARTS LIST (NOT ACTUAL SIZE)

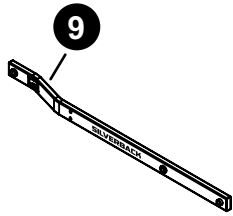

LOWER BOARD ARM ASSEMBLY RH
 (With SILVERBACK logo)
 1A-7949-20
 QTY. 1

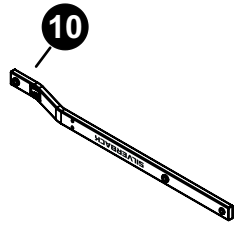

LOWER BOARD ARM ASSEMBLY LH
 (With SILVERBACK logo)
 1A-7950-20
 QTY. 1

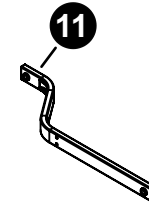

UPPER BOARD ARM ASSEMBLY
 (No logo)
 1A-7951-20
 QTY. 2

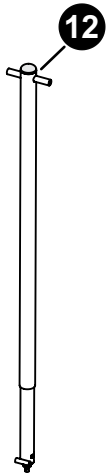

ACTUATOR
 4A-8284-00
 QTY.1



ACTUATOR COVER
 3M-9058-00
 QTY. 1
 (Pre-assembled to part #12)

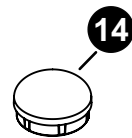

ACTUATOR COVER CAP
 3M-9059-00
 QTY. 1
 (Pre-assembled to part #13)

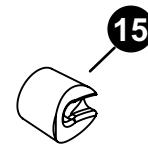

BUSHING, BOARD ARM
 3M-9057-00
 QTY. 4



HITCH PIN
 (For part #17 Crank)
 7B-6550-00
 QTY. 1

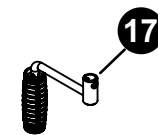

ACTUATOR CRANK ASSEMBLY
 4A-8285-00
 QTY. 1

PARTS LIST (NOT ACTUAL SIZE)

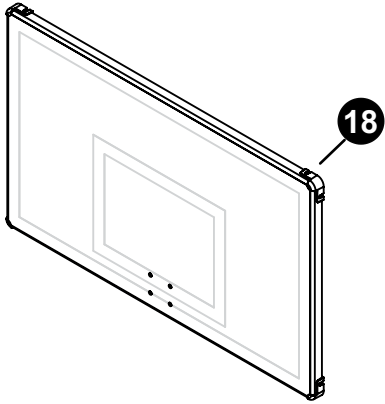

BACKBOARD ASSEMBLY, 60" x34"
4A-8677-20
QTY. 1

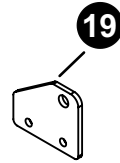

MOUNTING PLATE, BACKBOARD
2S-9421-20
QTY. 2

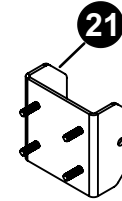

MOUNTING CHANNEL, BACKBOARD
1A-7952-20
QTY. 1

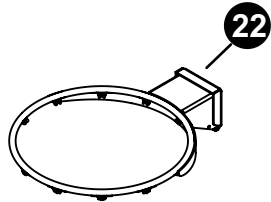

BREAK AWAY RIM ASSEMBLY
4A-8283-20
QTY. 1

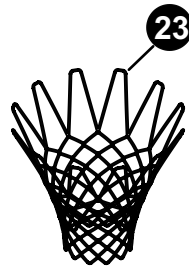

NET
3F-6010-00
QTY. 1

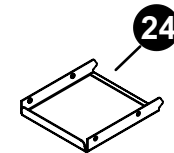

COVER PLATE
(For Rim Assembly)
2S-9422-20
QTY. 1

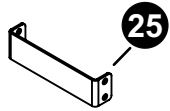

BRACE, BOARD ARM
2S-9424-20
QTY. 2

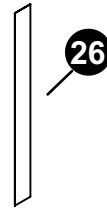

HEIGHT DECAL
4L-8635-00
QTY. 1

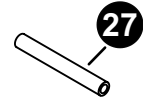

SPACER
2S-9423-00
QTY. 1
(Pre-assembled to part #12)

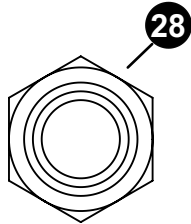

M12-1.75 HEX LOCK NUT
2B-6805-00
QTY. 8

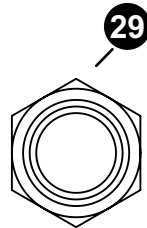

M10-1.5 HEX LOCK NUT
2B-6801-00
QTY. 6

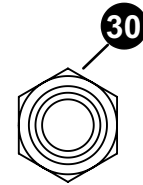

M8-1.25 HEX LOCKNUT
2B-6808-00
QTY. 12

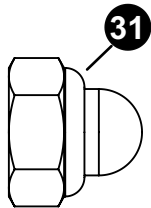

M10-1.5 HEX NUT, PROTECTIVE CAP
2B-6799-00
QTY. 1

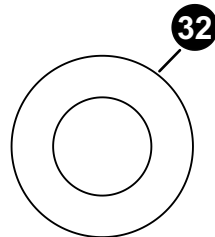

WASHER M12 X 24mm OD
2B-6804-00
QTY. 12

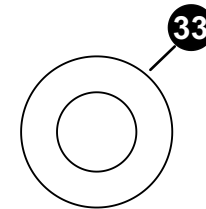

M10 WASHER
2B-6800-00
QTY. 6

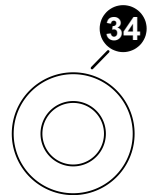

M8 WASHER
2B-6797-00
QTY. 24

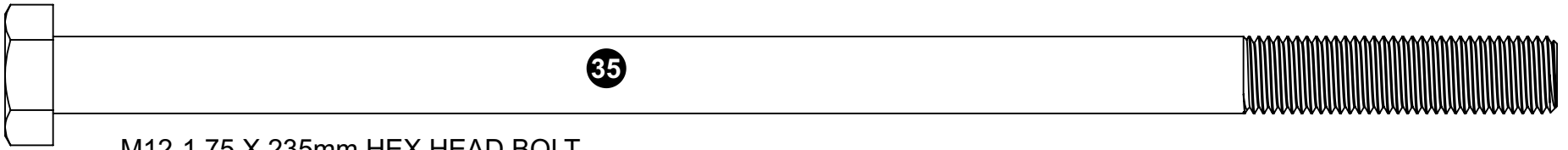

M12-1.75 X 235mm HEX HEAD BOLT
1B-7177-00
QTY. 1

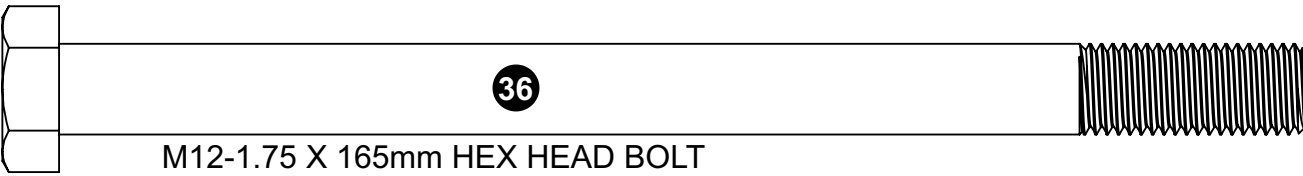

M12-1.75 X 165mm HEX HEAD BOLT
1B-7175-00
QTY. 1

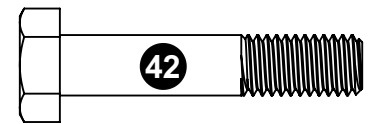

M8-1.25 X 40 HHCS ZINC
1B-7176-00
QTY. 8

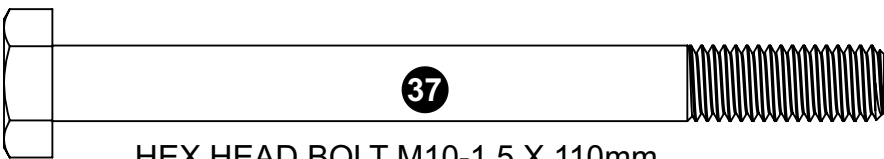

HEX HEAD BOLT M10-1.5 X 110mm
1B-7079-00
QTY. 2

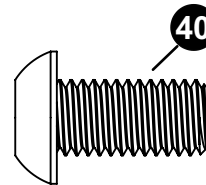

M10-1.5 X 20 BHCS STAINLESS STEEL
1B-7178-00
QTY.12

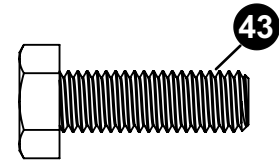

M8-1.25 X 25 HHCS
1B-7170-00
QTY. 4

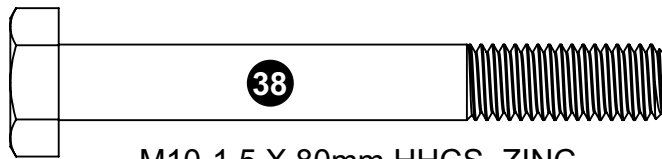

M10-1.5 X 80mm HHCS, ZINC
1B-7179-00
QTY. 1

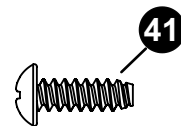

#8 X 1/2" THREAD FORMING SCREW
1B-6238-01
QTY. 7

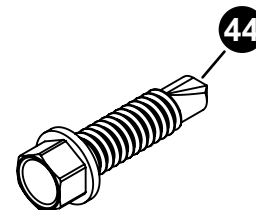

#10 X 1.0 ZINC SELF DRILLING / SELF TAPPING SCREW
1B-7039-00
QTY. 6

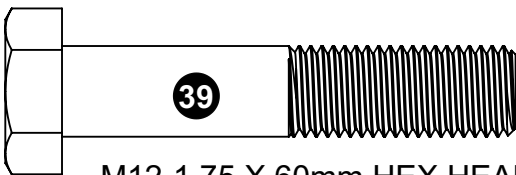

M12-1.75 X 60mm HEX HEAD BOLT
1B-7174-00
QTY. 2

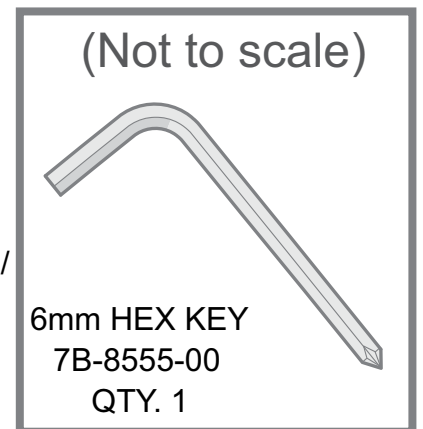

6mm HEX KEY
7B-8555-00
QTY. 1

NOTE

WITH THE HELP OF ANOTHER ADULT, SLIDE THE LOWER POLE (#1) AND MIDDLE POLE (#3) TOGETHER AS SHOWN. MAKE SURE TO LINE UP THE HOLES ON BOTH POLES.

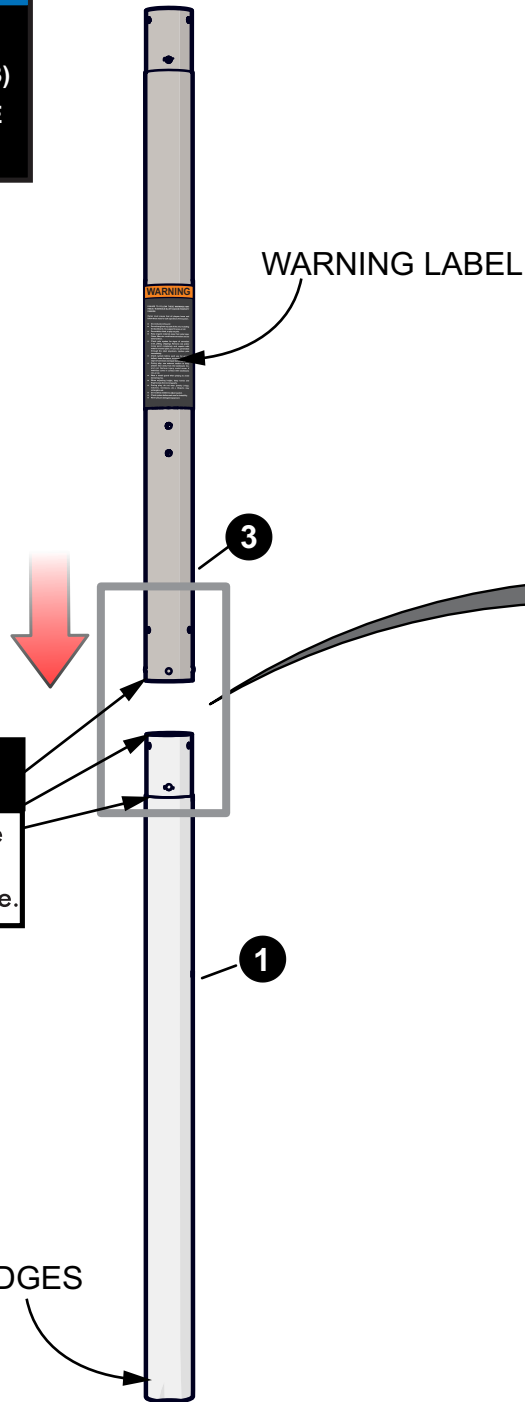

CAUTION:

PINCH POINTS! DO NOT place your hand on any of these three locations when inserting the pole.

HARDWARE NEEDED (ACTUAL SIZE)

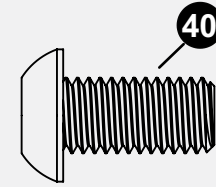

M10-1.5 X 20 BUTTON HEAD
STAINLESS STEEL BOLTS
1B-7178-00
(QTY. 6)

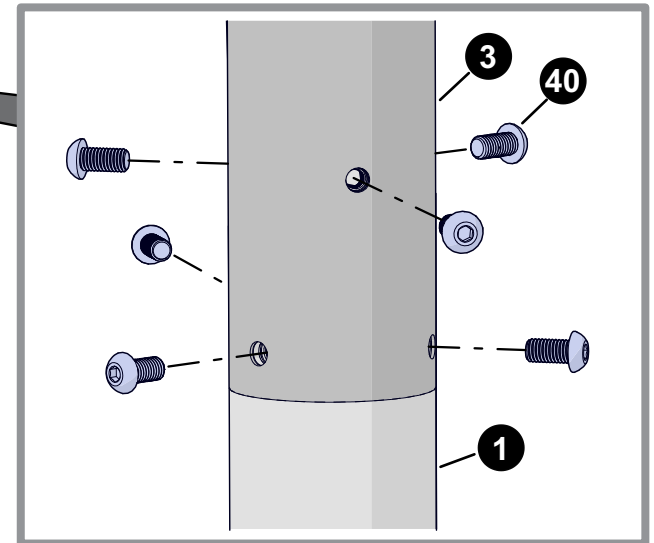

NOTE

INSERT 6 BUTTON HEAD SCREWS TO KEEP THE POLES TOGETHER AND HAND TIGHTEN THE BOLTS . DO NOT TIGHTEN WITH WRENCH.

TOOLS NEEDED

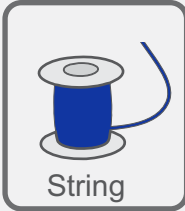
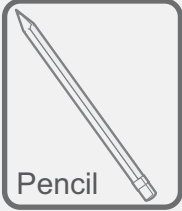

NOTE

THE FRONT OF THE POLE WILL HAVE THE WARNING DECAL AND DOUBLE HOLES. RUN A PIECE OF STRING FROM THE TOP CENTER HOLE OF THE MIDDLE POLE (A) TO THE BOTTOM CENTER HOLE (B) AND MARK THE CENTER OF THE BOTTOM POLE (#1) AS SHOWN.

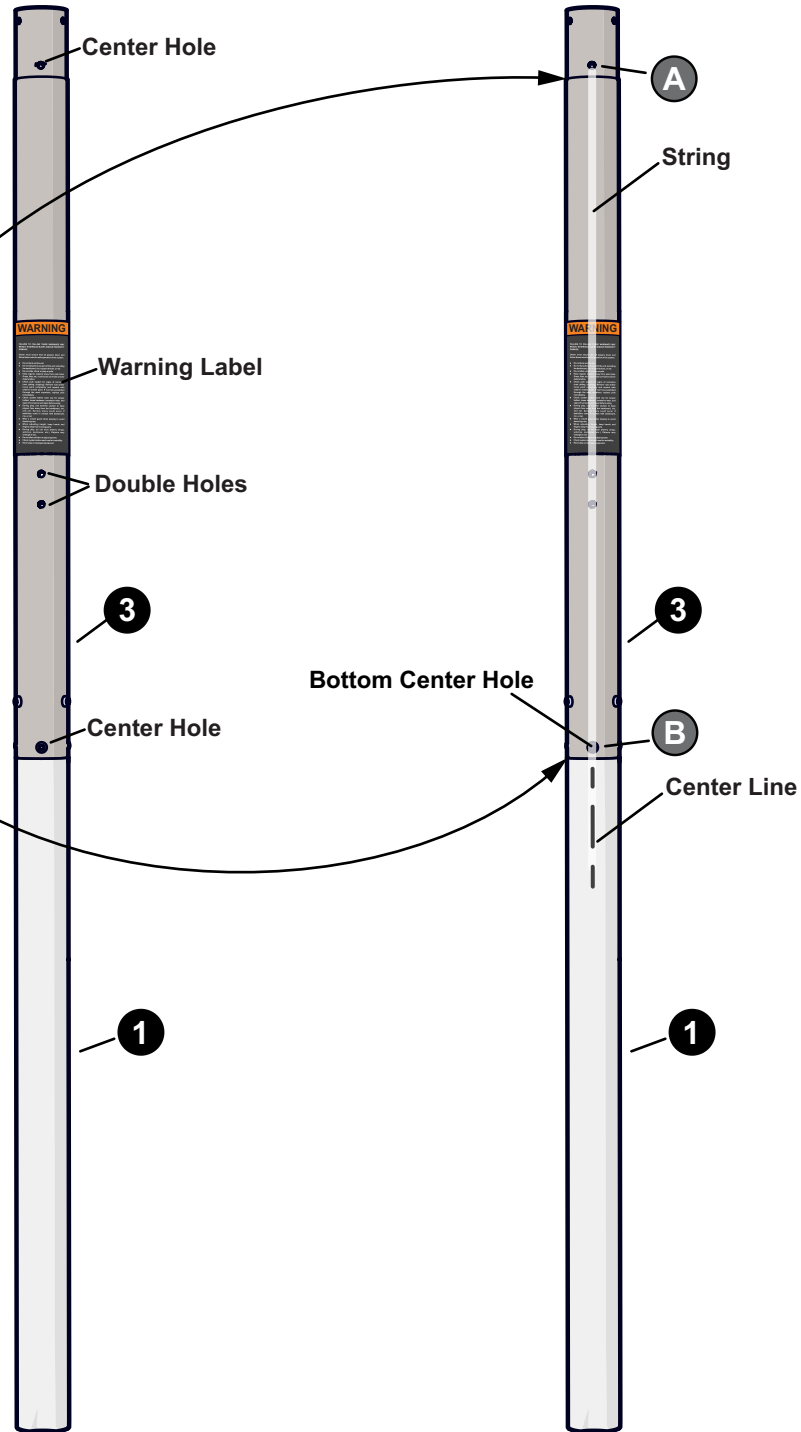

TOOLS NEEDED

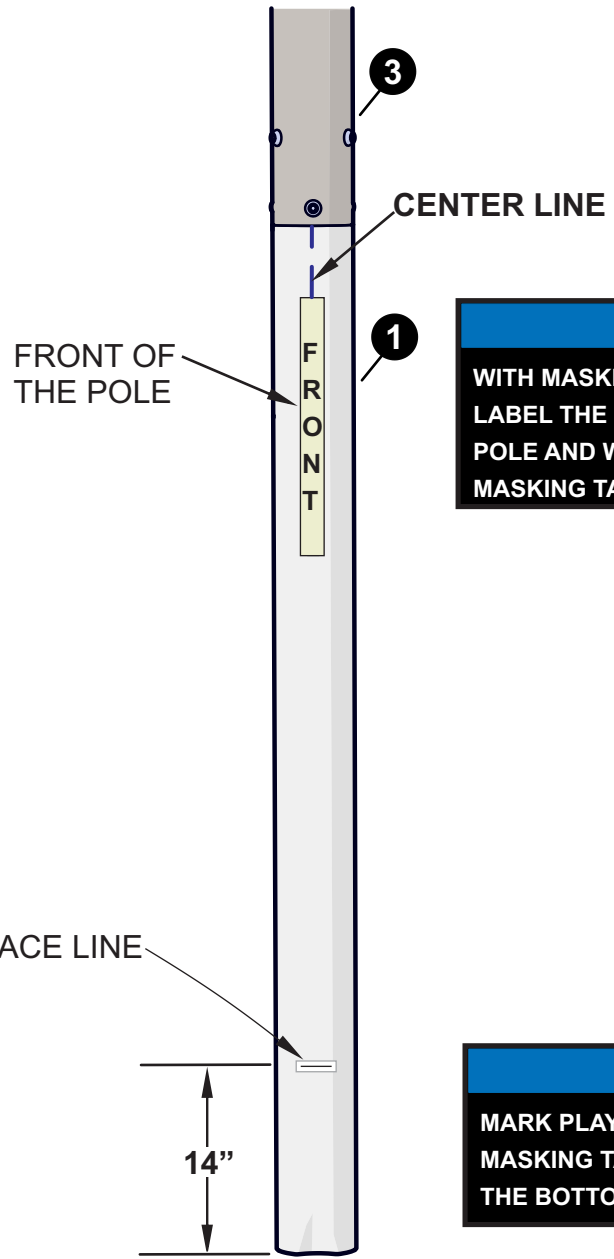
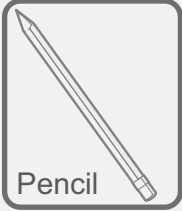

NOTE

WITH MASKING TAPE AND PENCIL, LABEL THE CENTER OF THE LOWER POLE AND WRITE "FRONT" ON THE MASKING TAPE.

NOTE

MARK PLAY SURFACE LINE WITH MASKING TAPE AND PENCIL 14" FROM THE BOTTOM OF THE POLE AS SHOWN.

NOTE

WITH THE HELP OF ANOTHER ADULT, REMOVE THE 6 BUTTON HEAD SCREWS AND TAKE THE MIDDLE (#3) AND BOTTOM (#1) POLES APART.

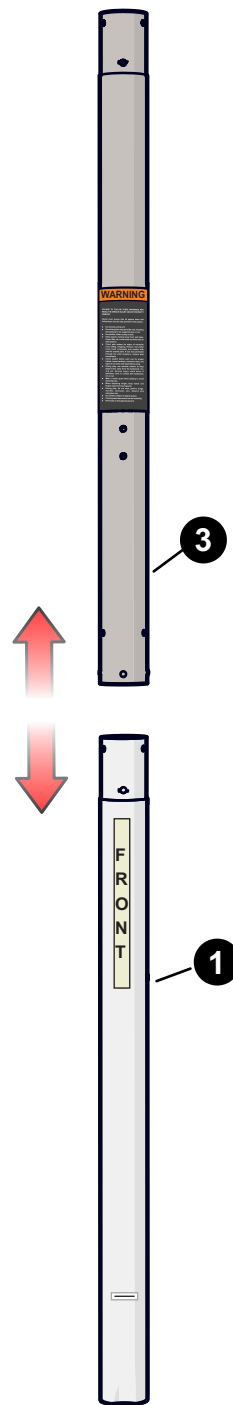

TOOL NEEDED

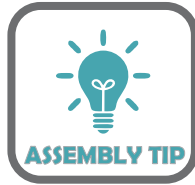

The following pages will have a picture of the **Hardware Needed** along with the Quantity, Part Number and Description. You can lay the hardware on the picture to identify the hardware.



HARDWARE NEEDED

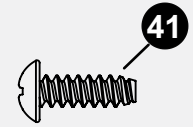

#8 X 1/2" THREAD FORMING SCREW
1B-6238-01
QTY. 2

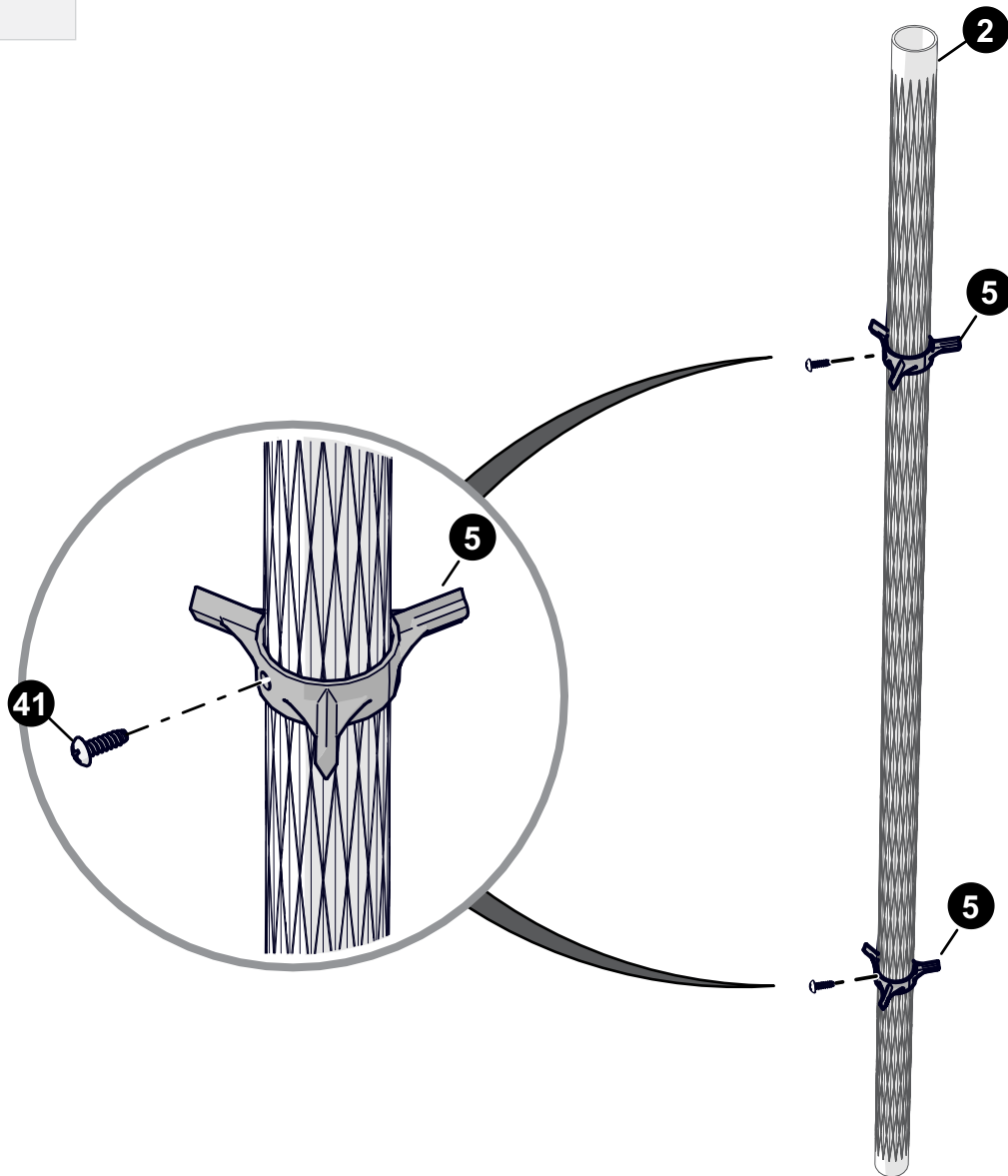

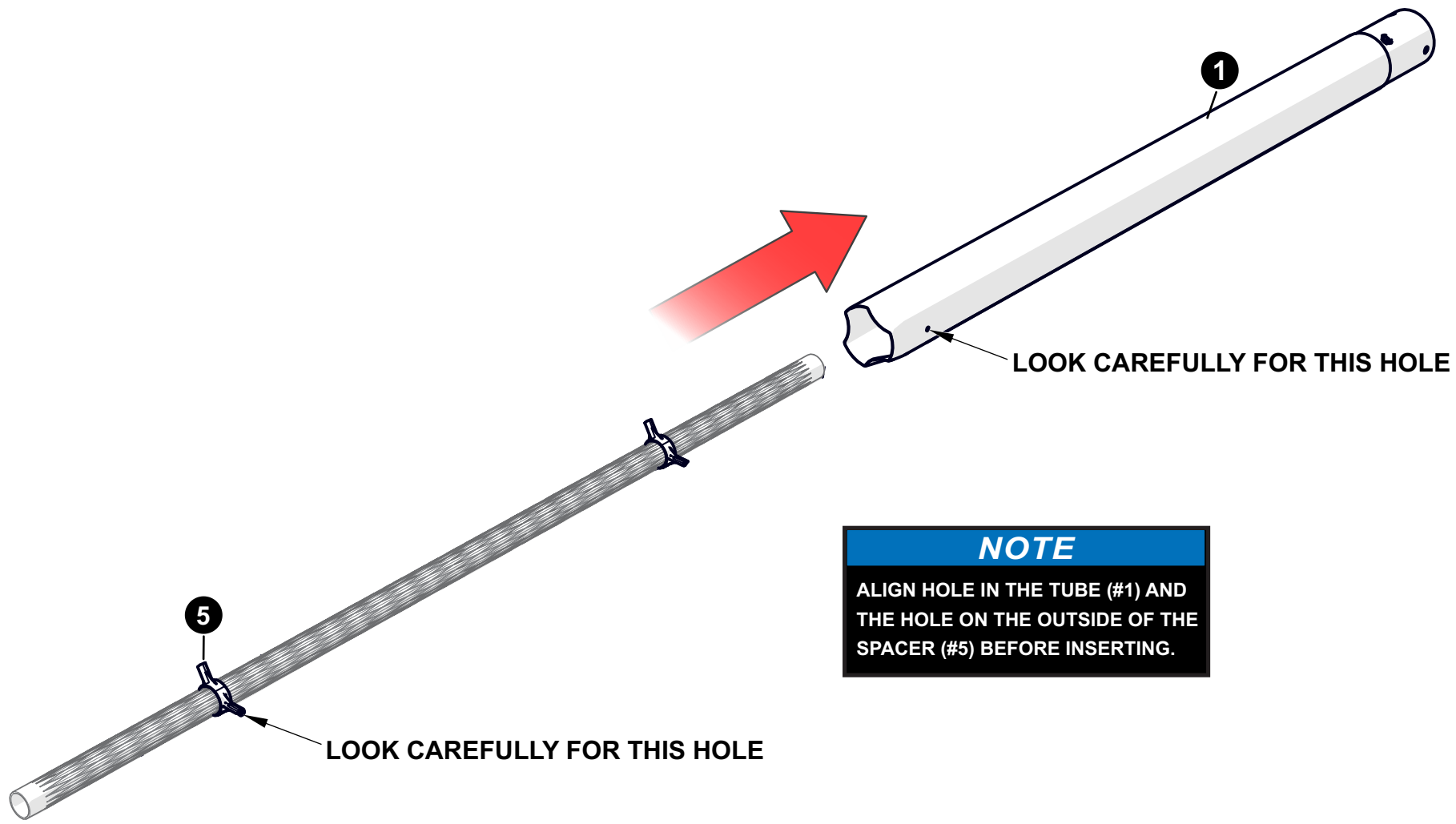

NOTE

ALIGN HOLE IN THE TUBE (#1) AND THE HOLE ON THE OUTSIDE OF THE SPACER (#5) BEFORE INSERTING.

TOOL NEEDED



HARDWARE NEEDED

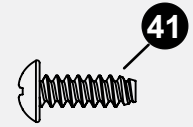

#8 X 1/2" THREAD FORMING SCREW
1B-6238-01
QTY. 1

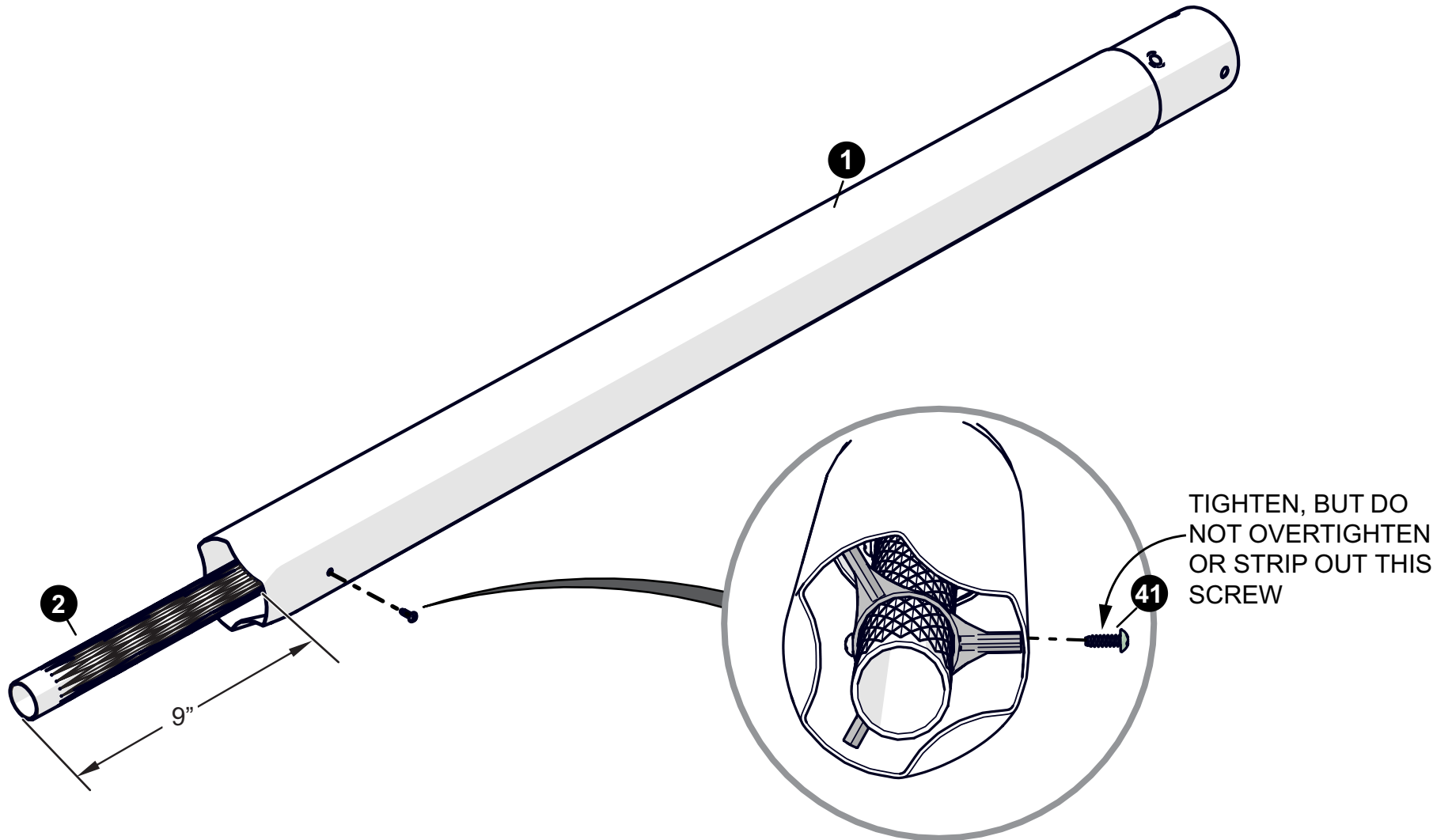

⚠ WARNING

Before digging the hole, contact your local One-Call system (dial 811) in your area.



Know what's below.
Call before you dig.
1-888-258-0808

Utility Markings

Color	Definition
Red	Electric
Yellow	Gas, Oil, Petroleum
Orange	Communication, Phone, TV
Blue	Potable Water, Irrigation
Green/Brown	Sewer
White	Proposed Dig

⚡ DANGER ⚡

Before digging hole for anchor system, check for buried power, gas, water, and telecommunication lines! Failure to do so could result in serious or fatal injury! Contact your local utility company if unsure.

Top View

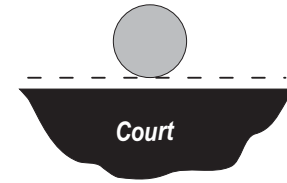

HOLE MUST BE CLOSE TO THE COURT EDGE WITHOUT MAKING CONTACT

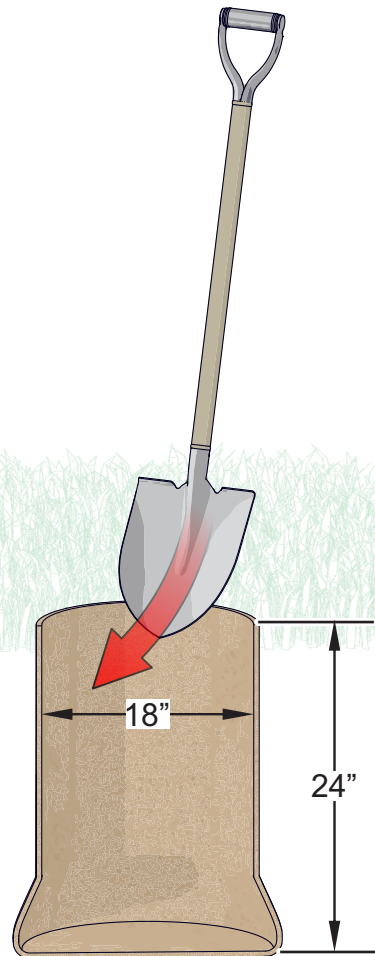

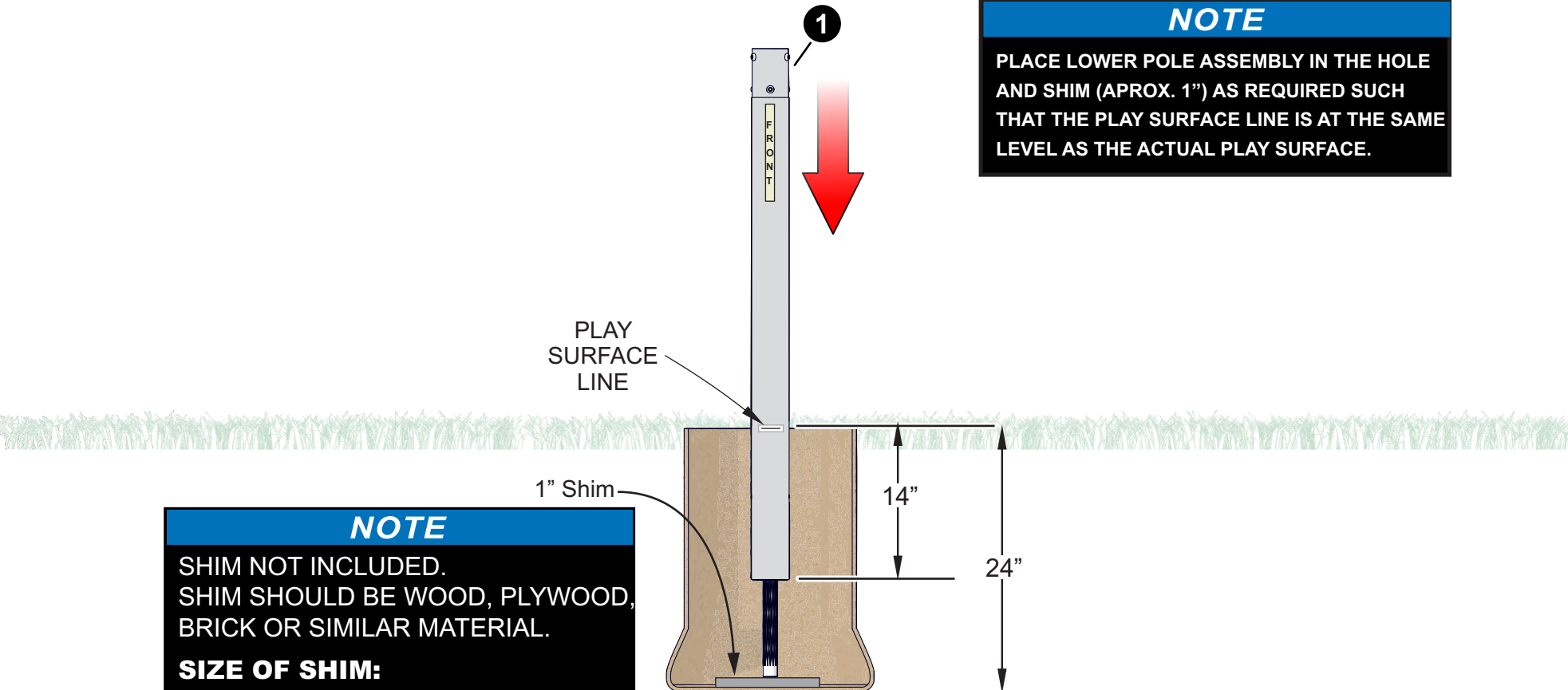

NOTE
 PLACE LOWER POLE ASSEMBLY IN THE HOLE AND SHIM (APROX. 1") AS REQUIRED SUCH THAT THE PLAY SURFACE LINE IS AT THE SAME LEVEL AS THE ACTUAL PLAY SURFACE.

NOTE
 SHIM NOT INCLUDED.
 SHIM SHOULD BE WOOD, PLYWOOD, BRICK OR SIMILAR MATERIAL.
SIZE OF SHIM:
 APPROXIMATELY 1" THICK OR NO LESS THAN 4" X 4".

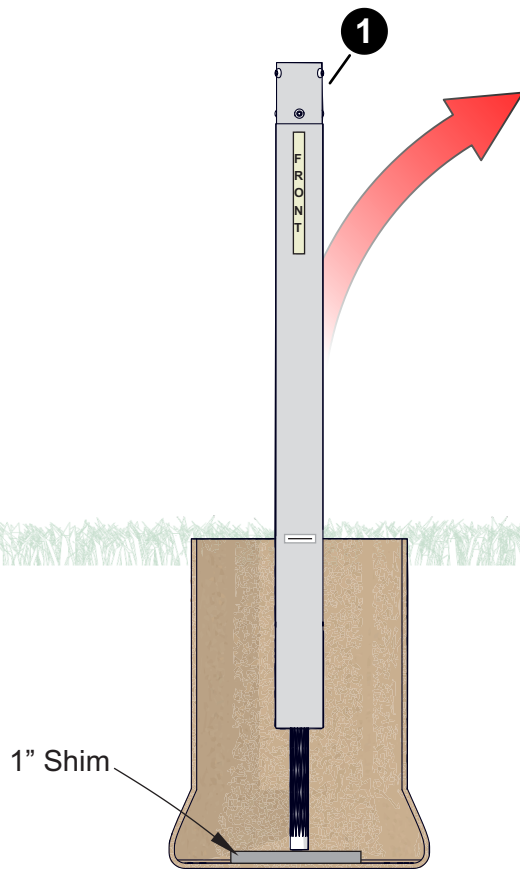

NOTE
TAKE THE BOTTOM POLE OUT BUT
LEAVE THE 1" SHIM IN PLACE.

NOTE

MIX 7 1/2 BAGS OF CONCRETE AND POUR INTO THE HOLE. IF NEEDED, MIX MORE CONCRETE UNTIL HOLE IS FILLED TO THE TOP.

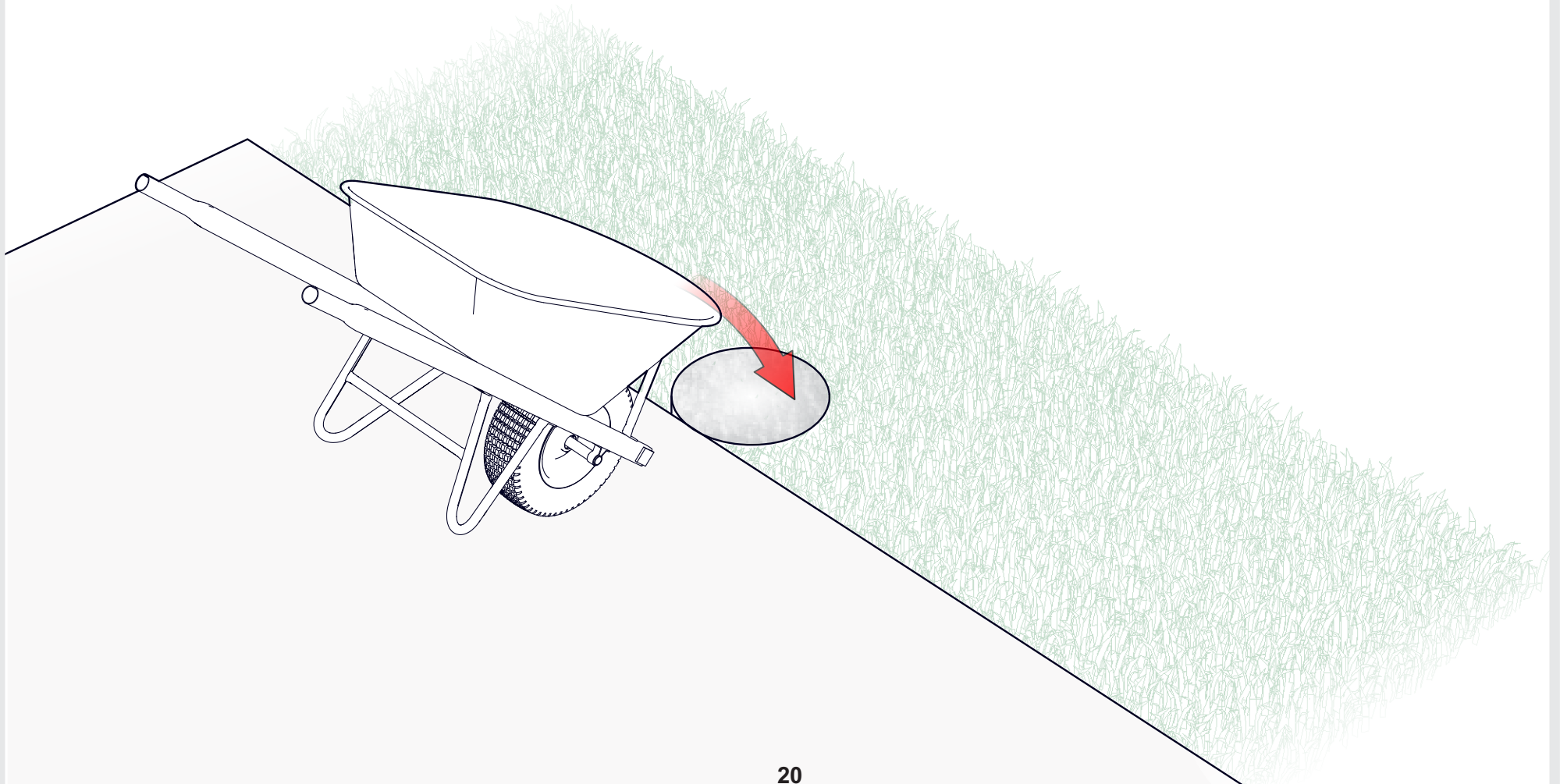

NOTE

SLOWLY LOWER POLE ASSEMBLY INTO CENTER OF HOLE UNTIL PLAY SURFACE LINE IS LEVEL WITH PLAY SURFACE. USE LEVEL TO MAKE SURE LOWER POLE ASSEMBLY IS VERTICAL. FRONT OF LOWER POLE FACES PLAYING SURFACE. SLOPE CONCRETE AWAY FROM POLE.

NOTE

“FRONT” OF POLE MUST BE EXACTLY FRONT IN RESPECT TO THE PLAYING SURFACE.

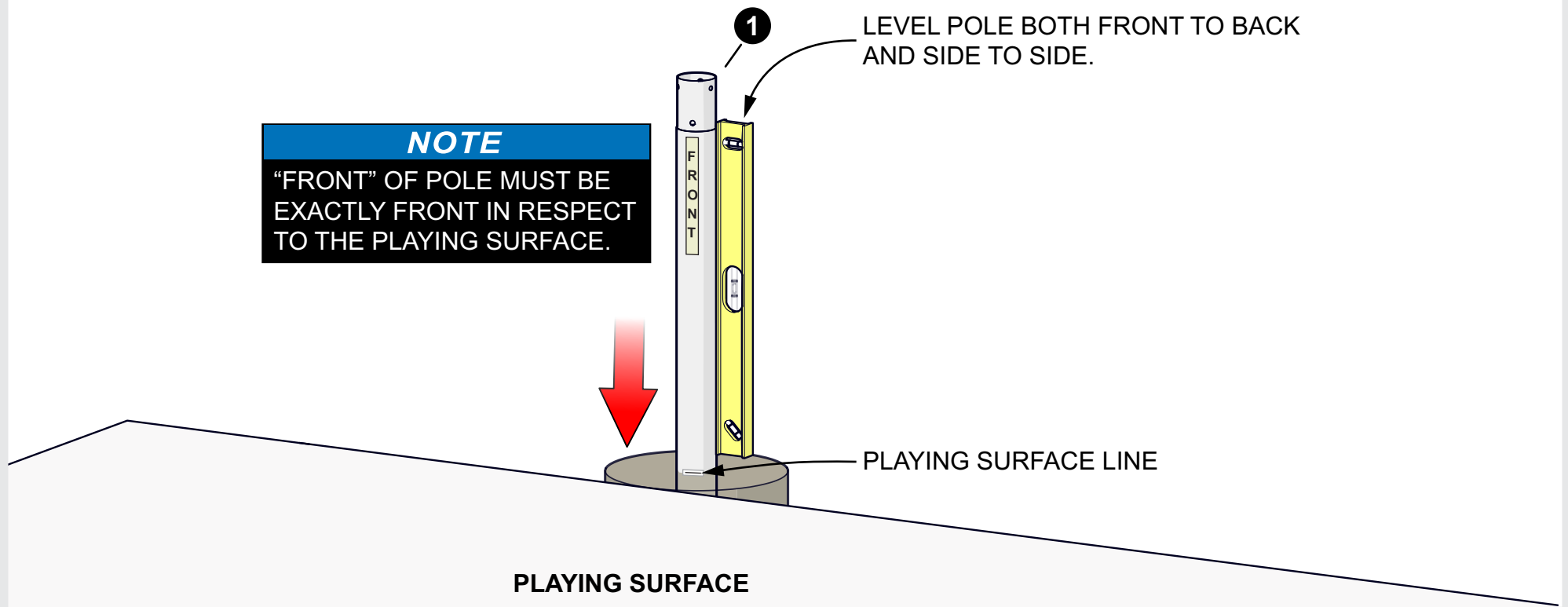

NOTE

FIXTURE LOWER POLE ASSEMBLY UNTIL CONCRETE CURES. PERIODICALLY CHECK THAT LOWER POLE ASSEMBLY IS VERTICAL AND LEVEL WITH PLAY SURFACE.

IMPORTANT!

Let concrete cure for a **MINIMUM** of 48 hours (2 days) before proceeding to the next step. In humid climates or wet weather, allow additional time for the concrete to cure. Do not install anything else until concrete is completely cured.

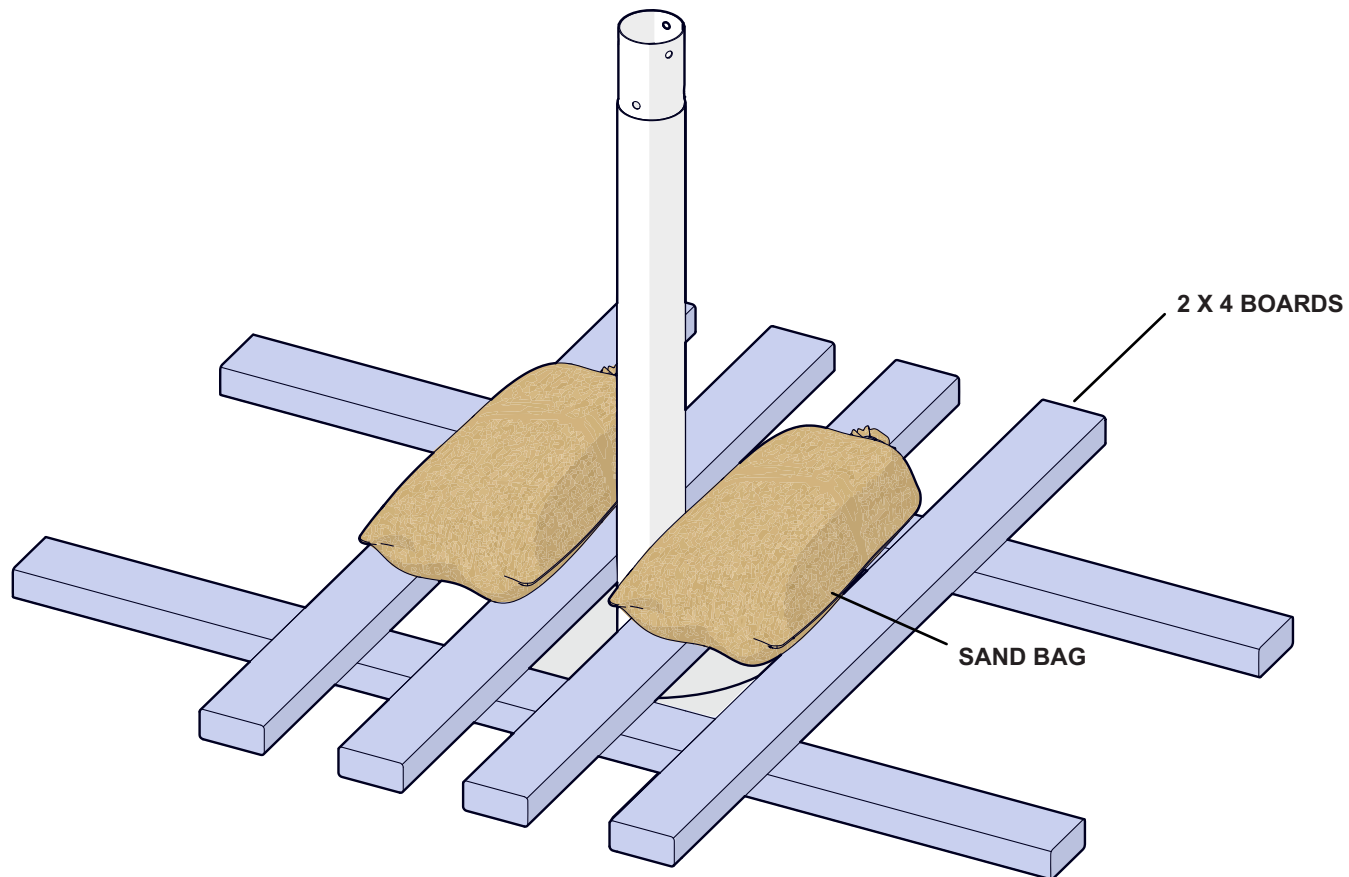

TOOLS NEEDED



&

TOOLS NEEDED



OR

TOOLS NEEDED



HARDWARE NEEDED (ACTUAL SIZE)

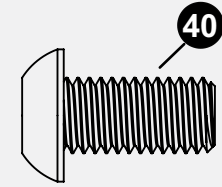

M10-1.5 X 20 BUTTON HEAD
STAINLESS STEEL BOLTS
1B-7178-00
(QTY. 6)

NOTE

COAT THREADS OF 6 BUTTON HEAD BOLTS WITH GREASE
AND INSERT INTO THREADED HOLES ON LOWER POLE.

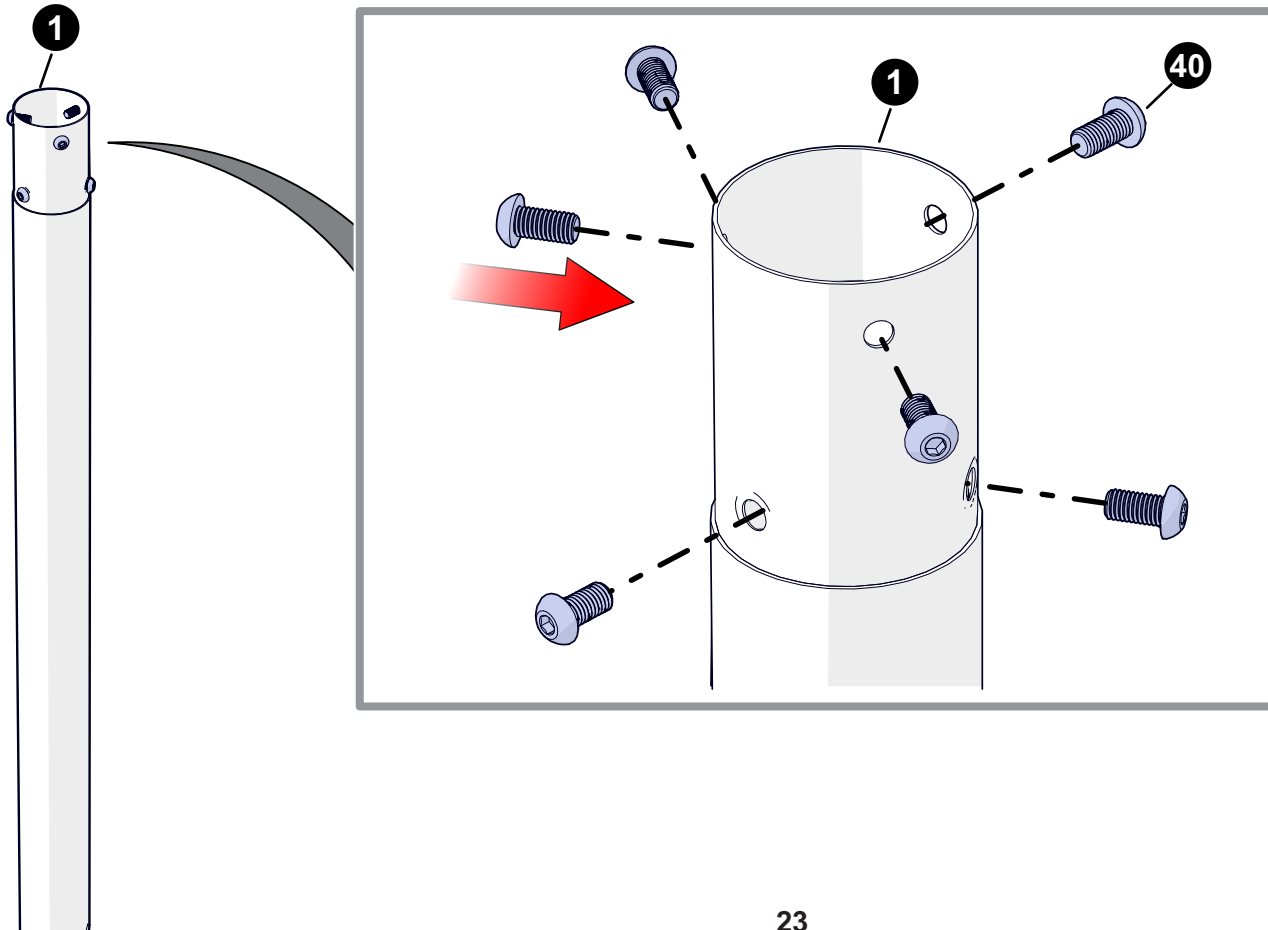

NOTE

MIX APPROXIMATELY 1/2 BAG OF CONCRETE IN A 5 GALLON BUCKET. THEN SLOWLY POUR CONCRETE INTO LOWER POLE AND REINFORCEMENT TUBE. OCCASIONALLY TAMP DOWN WITH 3/8" DOWEL TO REMOVE AIR AND MAKE SURE LOWER POLE AND REINFORCEMENT TUBE ARE FILLED. FILL TO TOP OF REINFORCEMENT TUBE. DO NOT OVER FILL.

You can continue with the installation on the next page immediately, concrete does not have to cure to continue with assembly.

NOTE

DO NOT OVERFILL LOWER POLE. ALL BOLT THREAD MUST STILL BE EXPOSED AFTER FILLING POLE WITH CONCRETE.

NOTE

3/8" X 48" WOOD DOWEL (NOT-INCLUDED) IS USED TO TAMP DOWN THE CONCRETE AND REMOVE AIR BUBBLES.

REINFORCEMENT TUBE

3/8" X 48" Wood Dowel

2

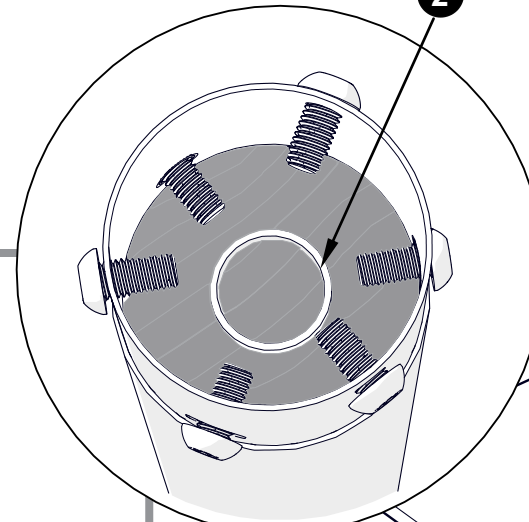

HELPFUL HINT:

WRAP POLE WITH OLD NEWSPAPER & MASKING TAPE TO HELP KEEP OUTER POLE FREE OF CONCRETE MIX.

NOTE

AFTER FILLING POLE WITH CONCRETE, QUICKLY WASH OFF ANY CONCRETE MIX ON THE OUTER POLE.

DO NOT FILL PAST THIS POINT

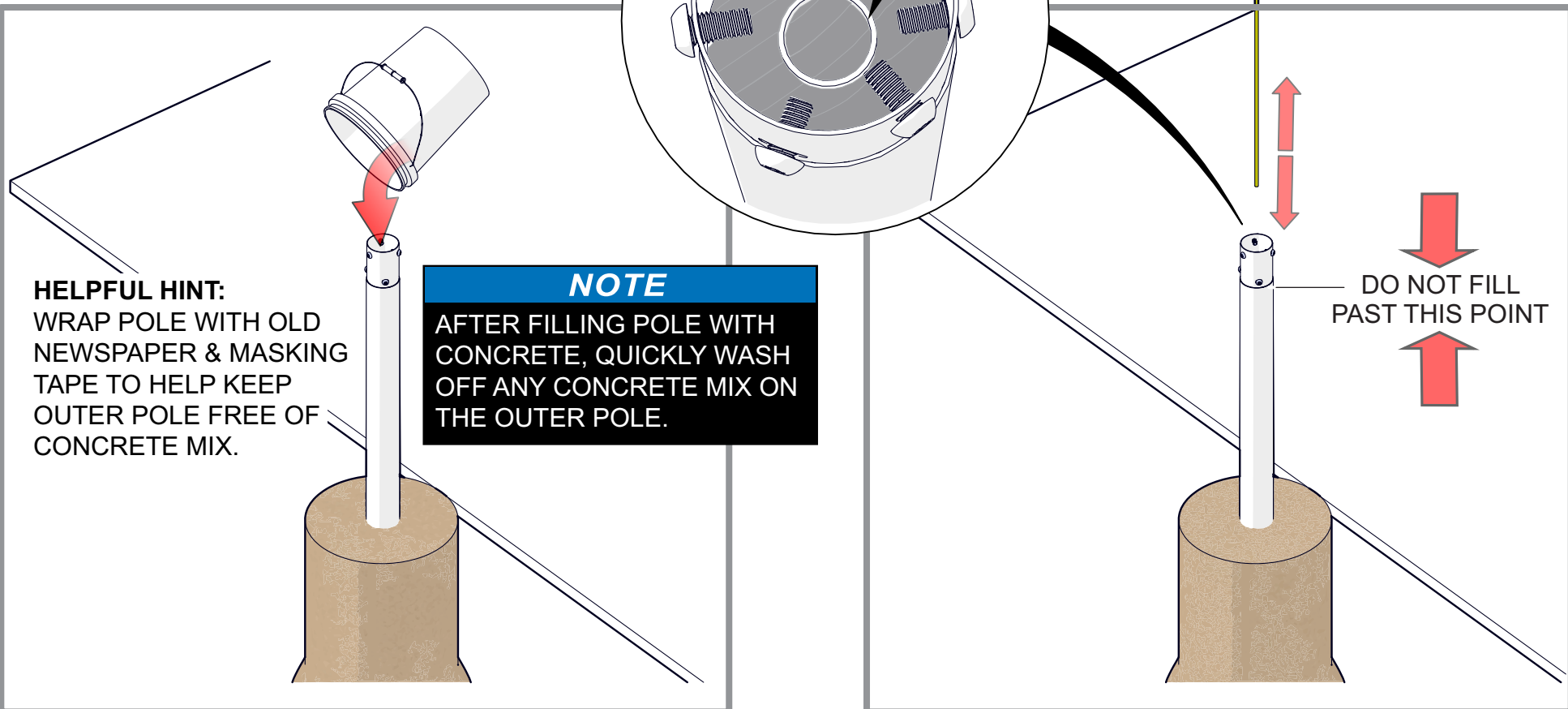

TOOLS NEEDED

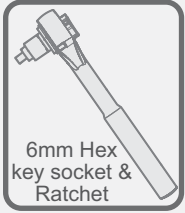

OR

TOOLS NEEDED

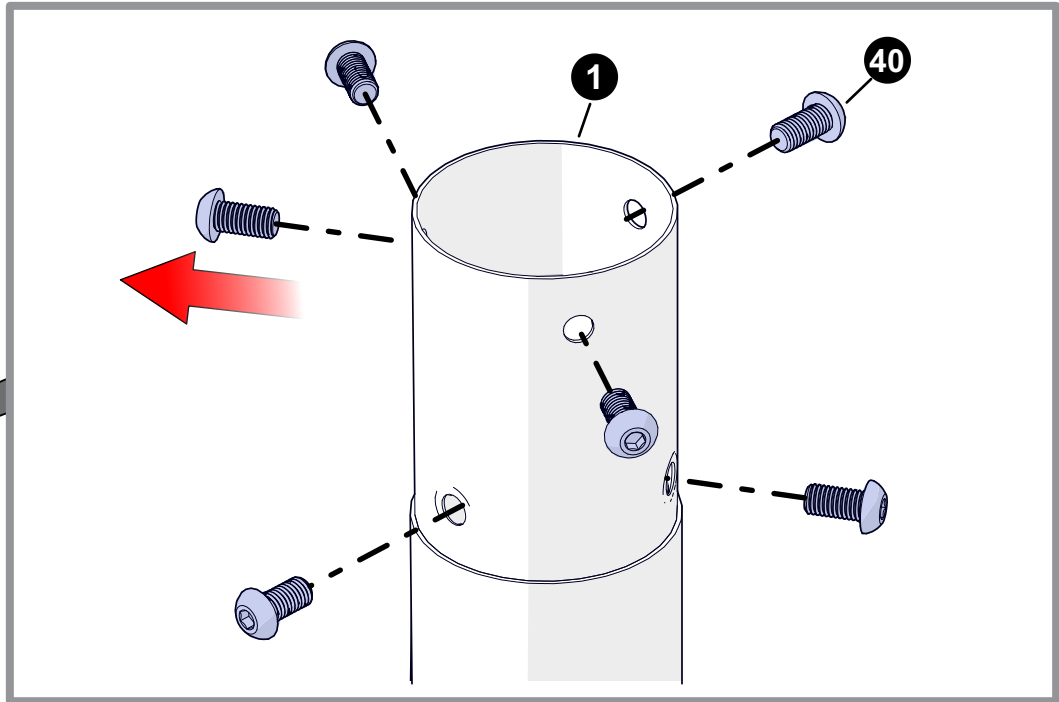

REMOVE ALL BOLTS.



TOOLS NEEDED

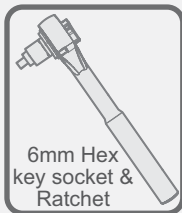

6mm Hex key socket & Ratchet

OR

TOOLS NEEDED



6mm

HARDWARE NEEDED (ACTUAL SIZE)

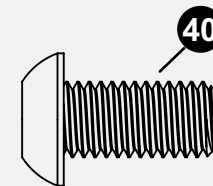

M10-1.5 X 20 BUTTON HEAD STAINLESS STEEL BOLTS
1B-7178-00
(QTY. 6)

NOTE

"FRONT" OF POLE MUST BE EXACTLY FRONT IN RESPECT TO THE PLAYING SURFACE.

IMPORTANT

WARNING LABEL FACES TOWARD THE COURT SURFACE

CAUTION:

PINCH POINTS! DO NOT place your hand on any of these three locations when inserting the pole.

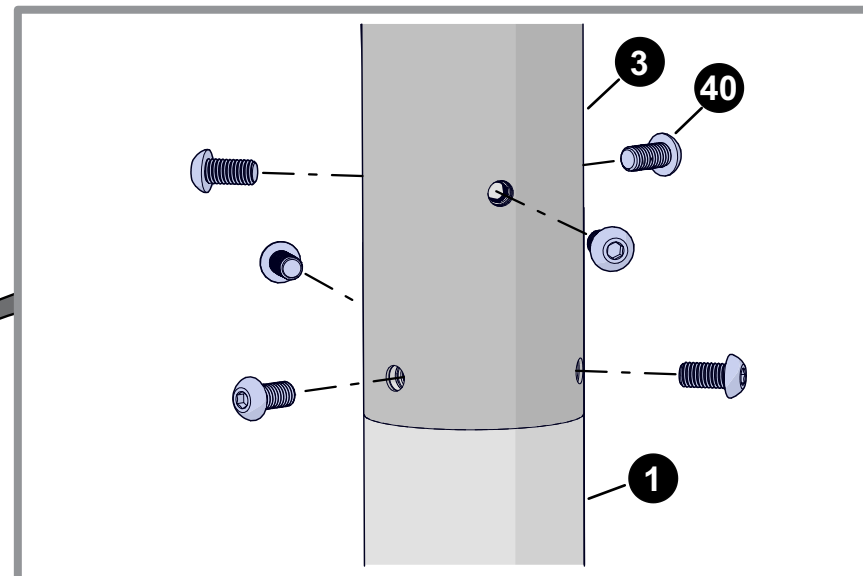
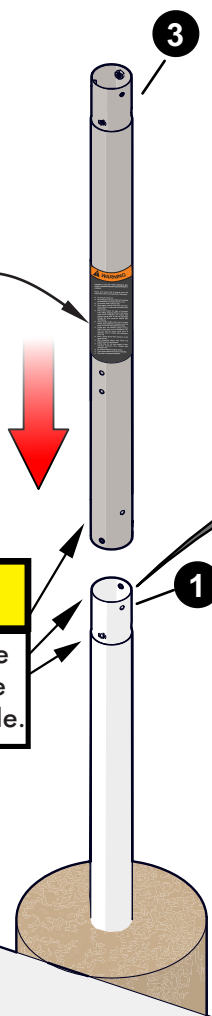

CAREFULLY INSTALL SIX #40 BOLTS - TIGHTEN.

COURT SURFACE

HARDWARE NEEDED (ACTUAL SIZE)

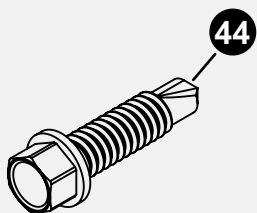

#10 X 1.0 ZINC SELF DRILLING /
SELF TAPPING SCREW
1B-7039-00
QTY. 3

TOOLS REQUIRED

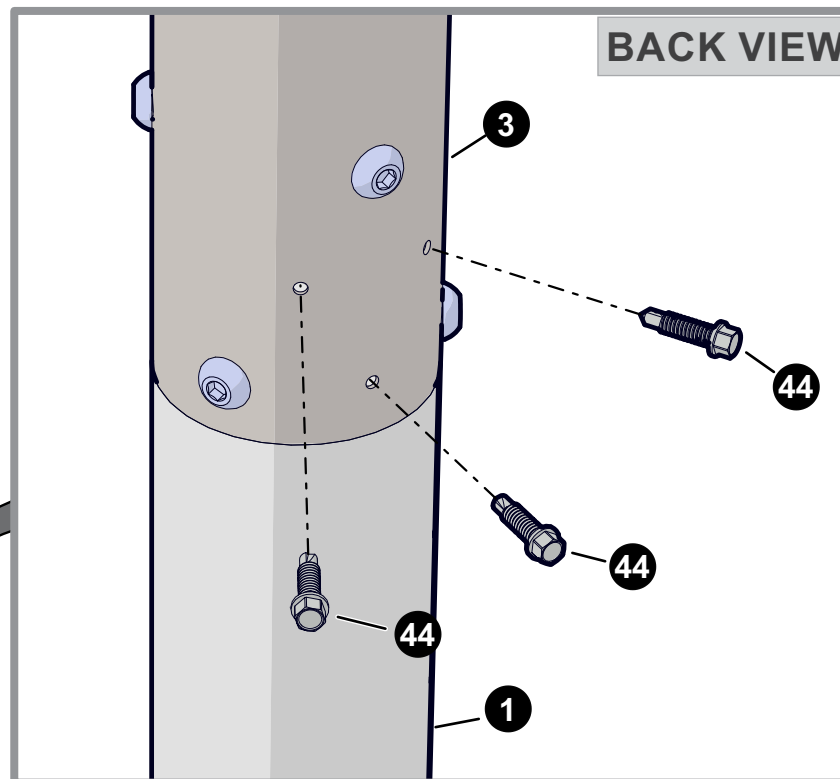
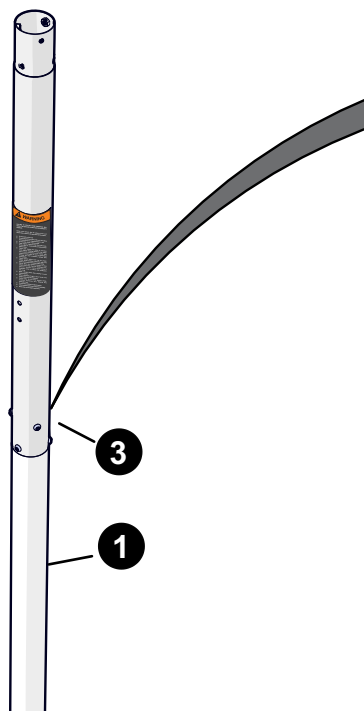
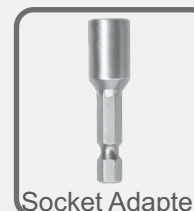
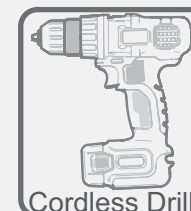

NOTE

INSERT THREE (#44) SCREWS IN THE PRE-DRILLED
HOLES IN THE BACK OF THE POLE. TIGHTEN
UNTIL TIGHT BUT DO NOT OVER-TIGHTEN.

HARDWARE NEEDED (ACTUAL SIZE)

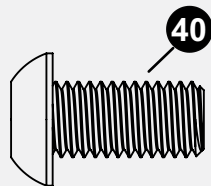

M10-1.5 X 20 BUTTON HEAD
STAINLESS STEEL BOLTS
1B-7178-00
(QTY. 6)

TOOLS NEEDED

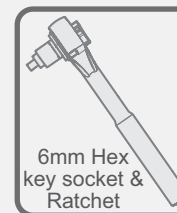

6mm Hex
key socket &
Ratchet

OR

TOOLS NEEDED



6mm

IMPORTANT
LOWER BOARD ARM PIVOT BAR
AND THE WARNING LABEL FACE
TOWARDS THE COURT SURFACE

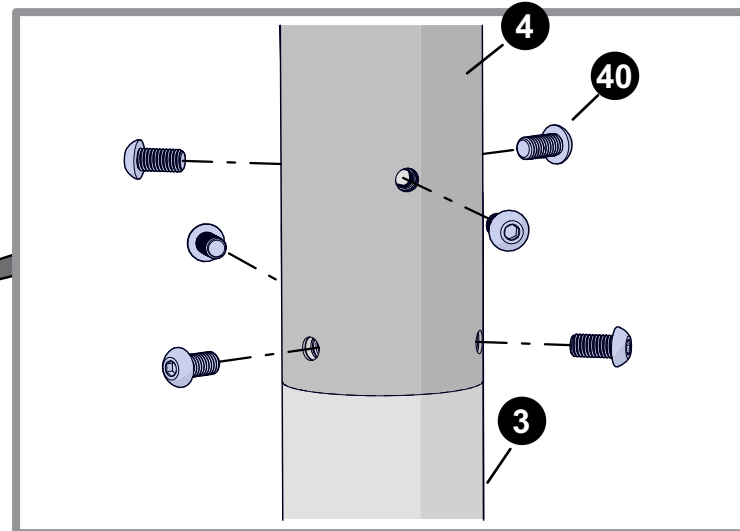
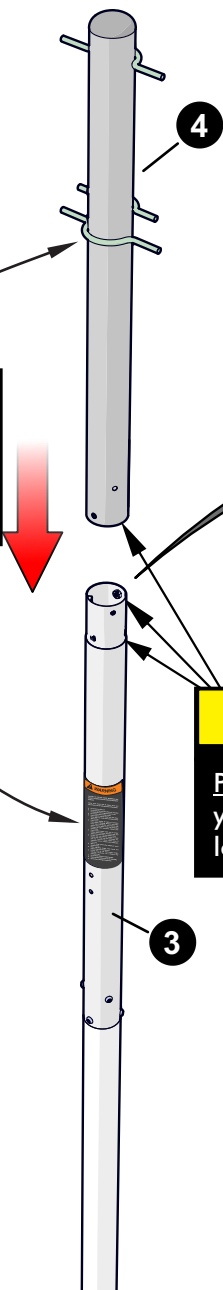

CAUTION:
PINCH POINTS! **DO NOT** place
your hand on any of these three
locations when inserting the pole.

CAREFULLY INSTALL SIX
#40 BOLTS - TIGHTEN.

HARDWARE NEEDED (ACTUAL SIZE)

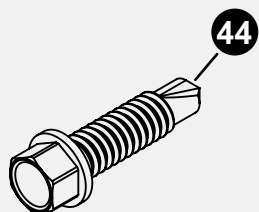

#10 X 1.0 ZINC SELF DRILLING /
SELF TAPPING SCREW
1B-7039-00
QTY. 3

TOOLS REQUIRED



Cordless Drill



Socket Adapter

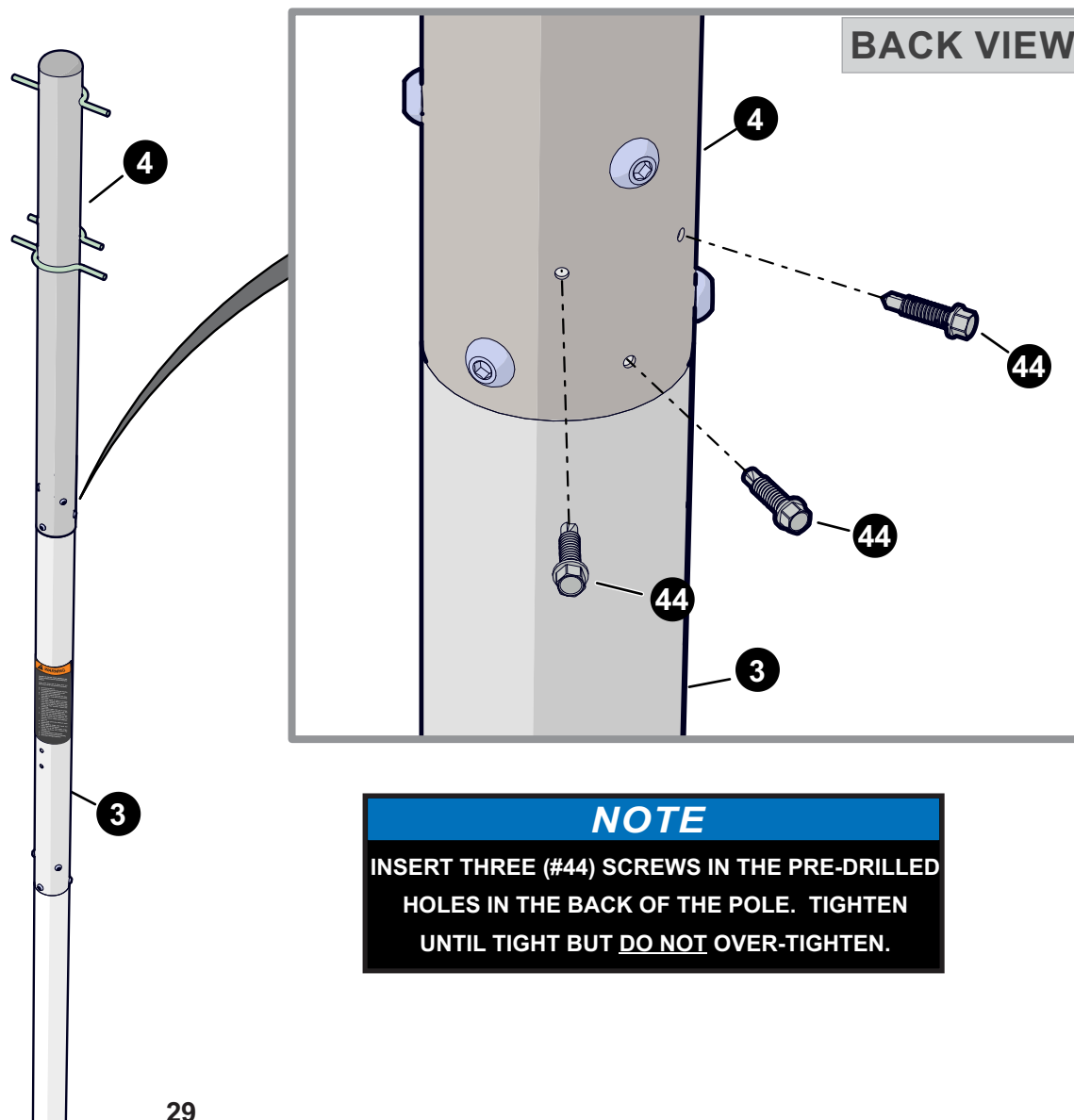

BACK VIEW

NOTE

INSERT THREE (#44) SCREWS IN THE PRE-DRILLED
HOLES IN THE BACK OF THE POLE. TIGHTEN
UNTIL TIGHT BUT DO NOT OVER-TIGHTEN.

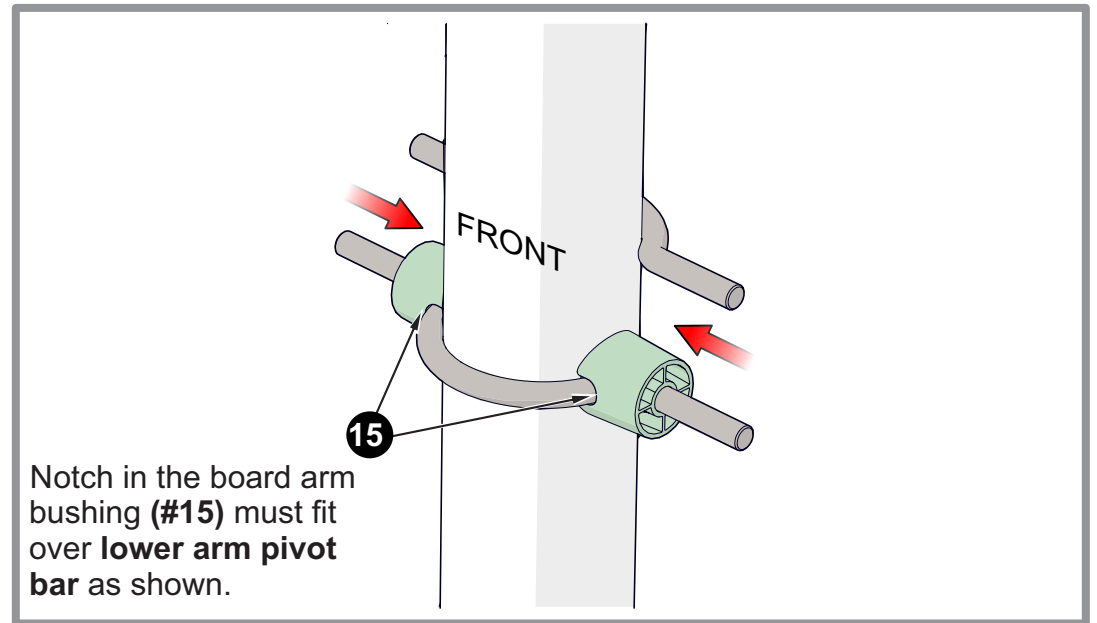
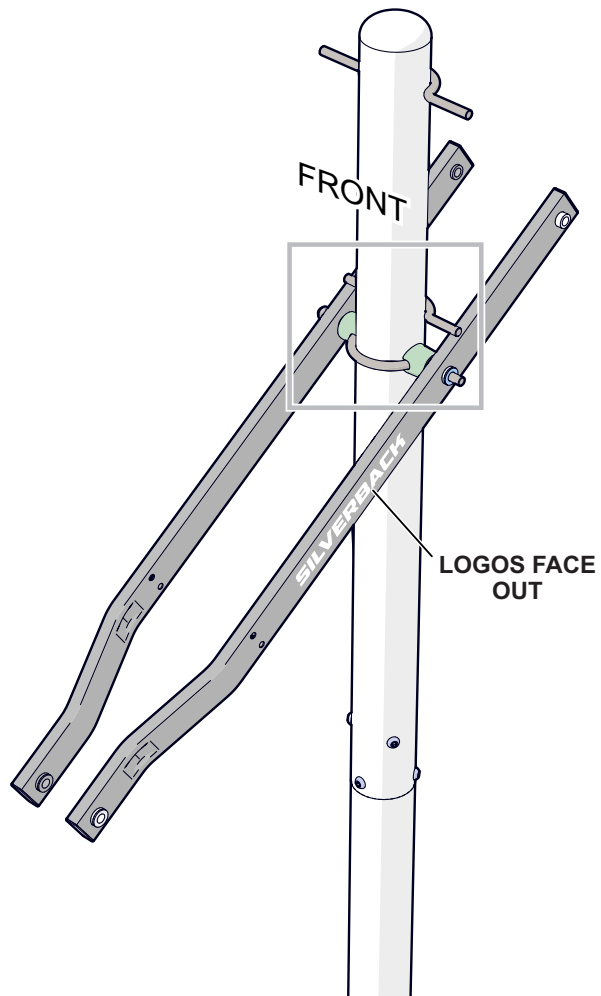

NOTE

BEFORE INSTALLING ARM MAKE SURE THAT THE PLASTIC BUSHINGS ARE PRE-INSTALLED IN THE METAL SLEEVE OF THE ARM AS SHOWN. IF PARTS ARE NOT PRE-ASSEMBLED OR IN THE BOX PLEASE CALL OUR CUSTOMER SERVICE DEPARTMENT.

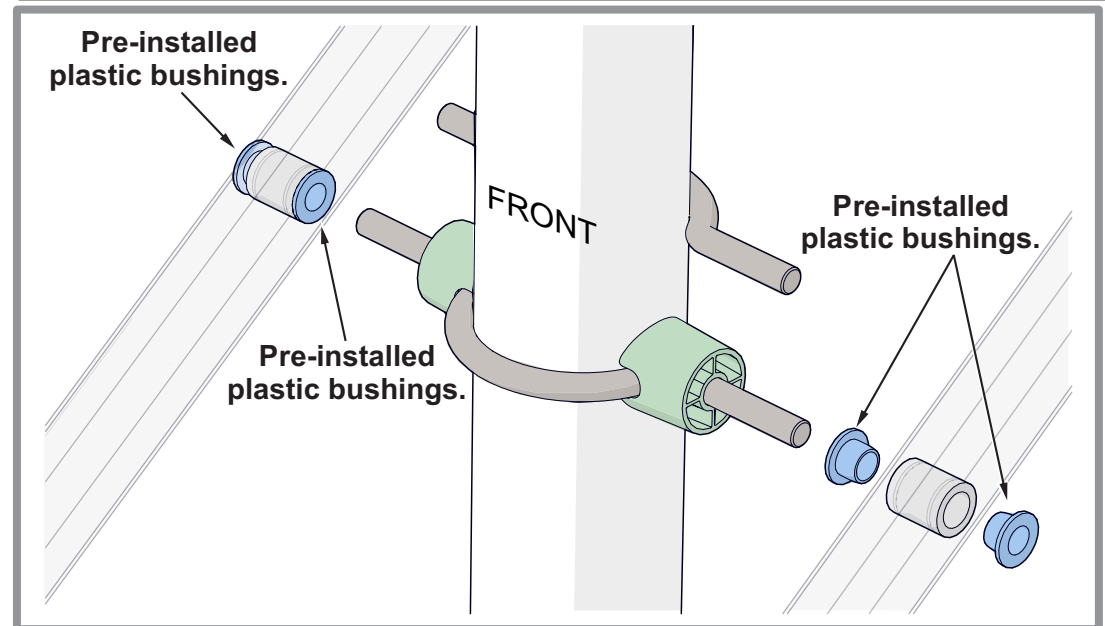

HARDWARE NEEDED (ACTUAL SIZE)

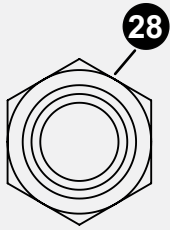

M12-1.75 HEX LOCK NUT
2B-6805-00
QTY. 2

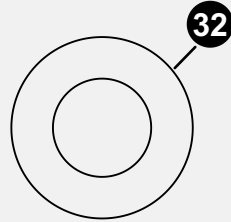

WASHER M12 X 24mm OD
2B-6804-00
QTY. 2

TOOLS NEEDED

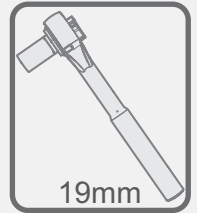

19mm

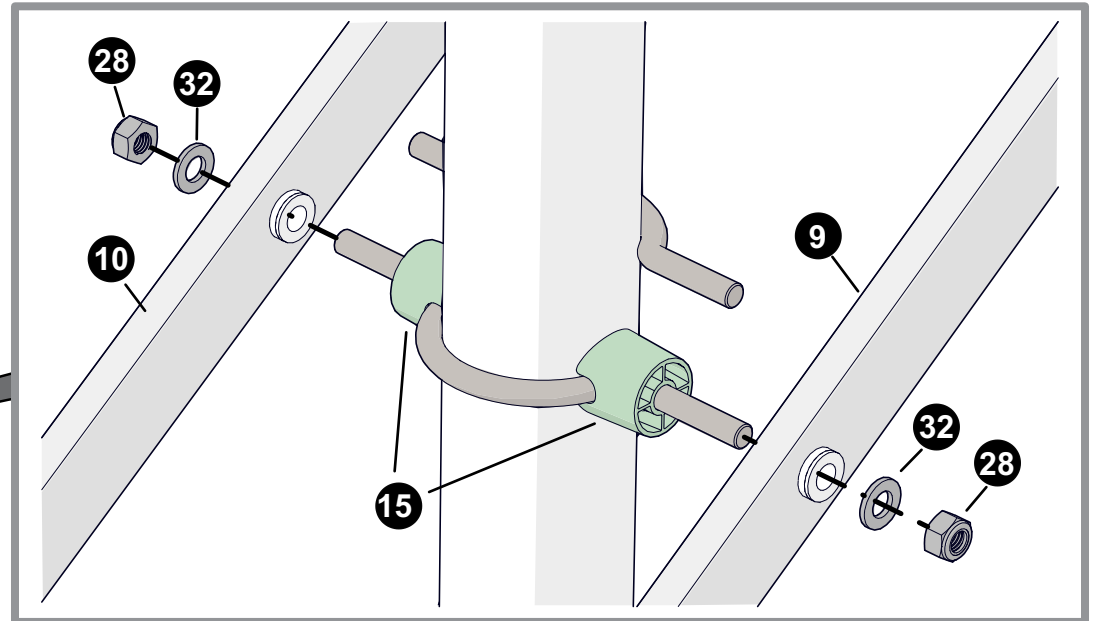
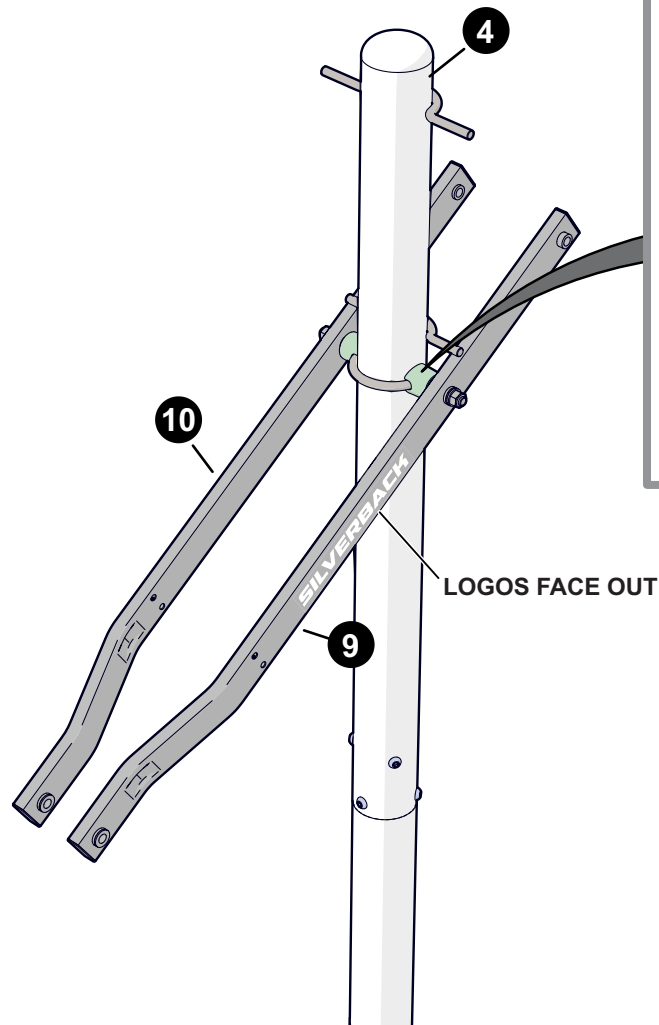

NOTE

**Tighten hardware but back off half a turn
once you feel the hardware is snug.**

TOOLS NEEDED

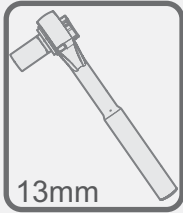
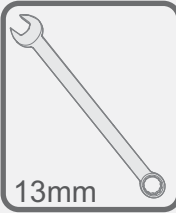

HARDWARE NEEDED (ACTUAL SIZE)

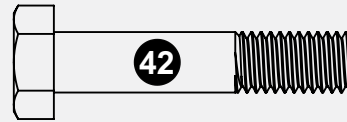

M8-1.25 X 40 HHCS ZINC
1B-7176-00
QTY. 4

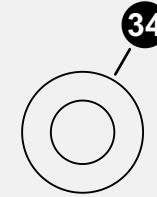

WASHER M8
2B-6797-00
QTY. 8

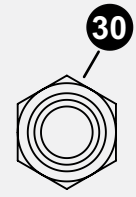

M8-1.25 HEX LOCKNUT
2B-6808-00
QTY. 4

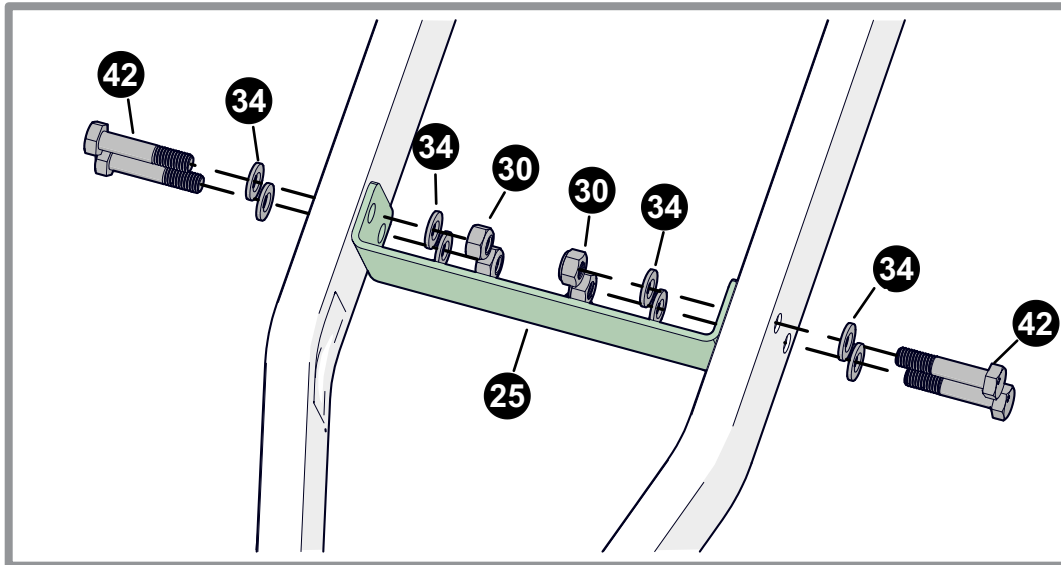

NOTE

Tighten hardware about 3/4ths of the way. Leave loose enough to attach the mounting channel (#21) on the next page.

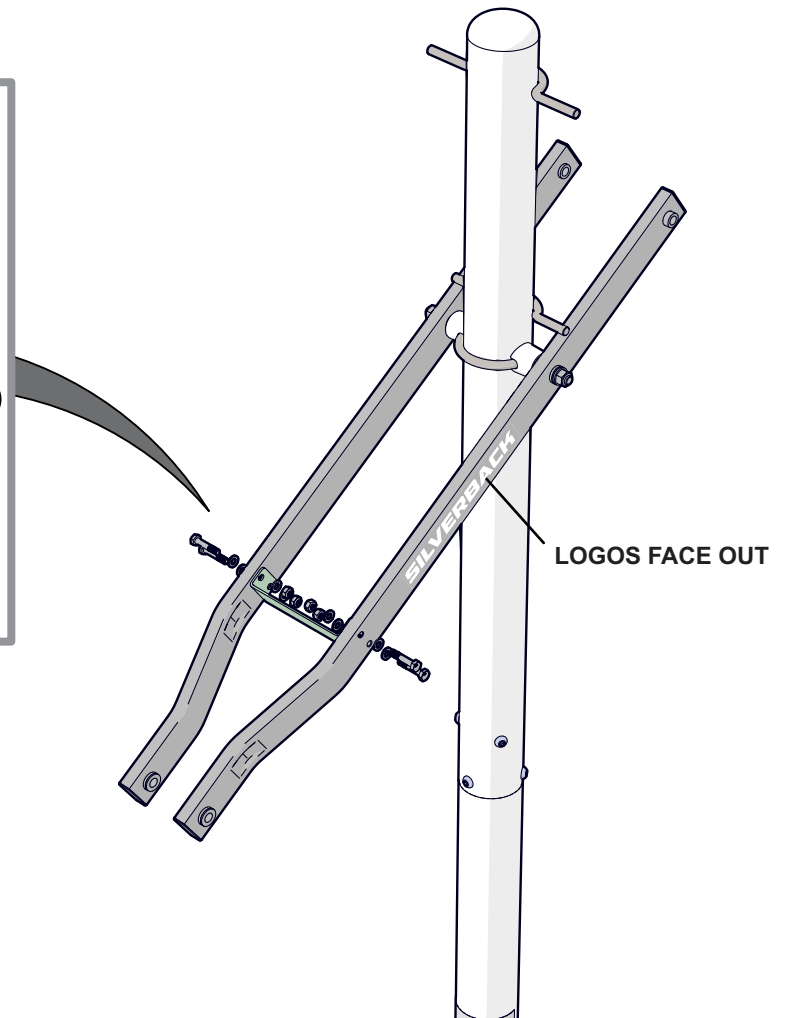

HARDWARE NEEDED (ACTUAL SIZE)

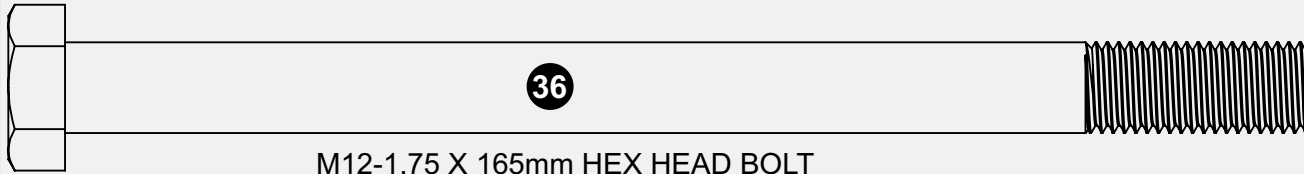

M12-1.75 X 165mm HEX HEAD BOLT
1B-7175-00
QTY. 1

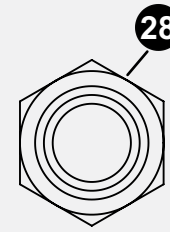

M12-1.75 HEX LOCK NUT
2B-6805-00
QTY. 1

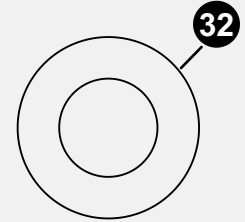

WASHER M12 X 24mm OD
2B-6804-00
QTY. 2

TOOLS NEEDED

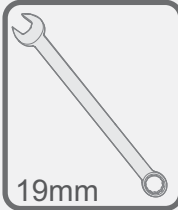

19mm

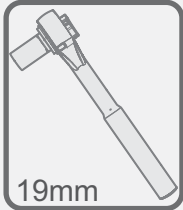

19mm

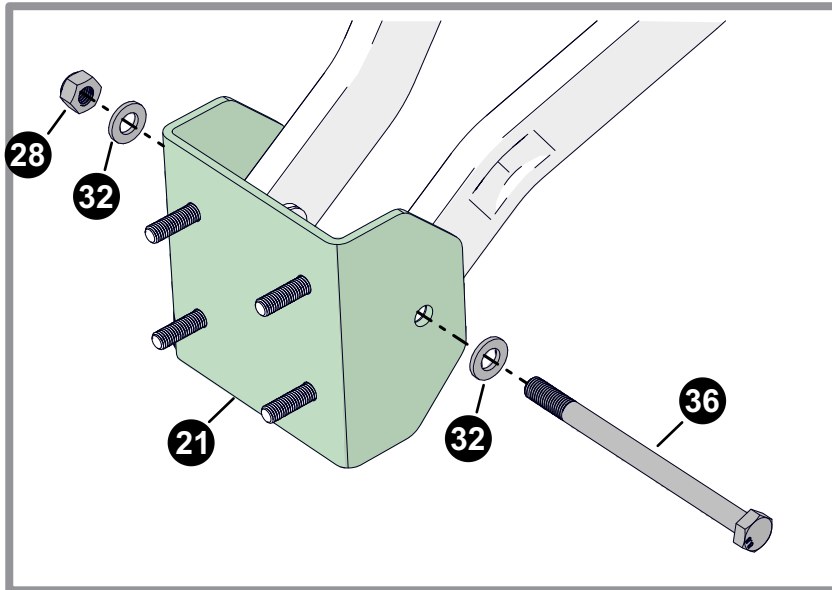

NOTE

Tighten hardware but back off half a turn once you feel the hardware is snug.

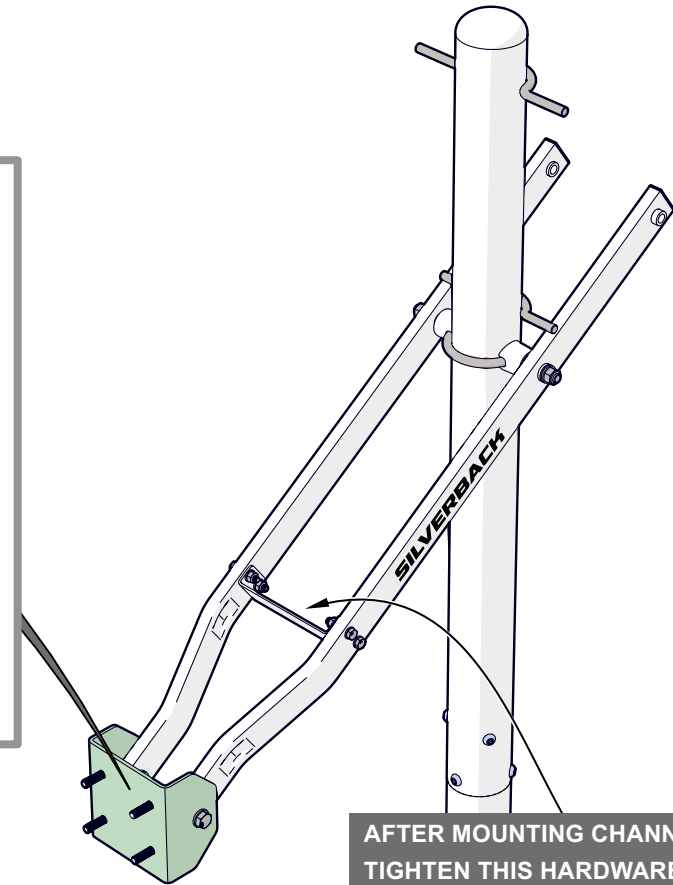

AFTER MOUNTING CHANNEL (#21), TIGHTEN THIS HARDWARE UNTIL IT IS SECURE, SNUG IS TIGHT ENOUGH.

HARDWARE NEEDED (ACTUAL SIZE)

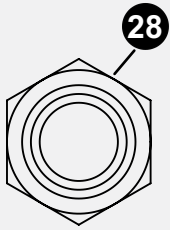

M12-1.75 HEX LOCK NUT
2B-6805-00
QTY. 2

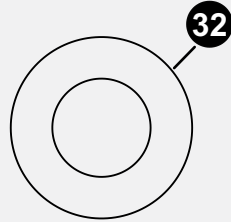

WASHER M12 X 24mm OD
2B-6804-00
QTY. 2

TOOLS NEEDED

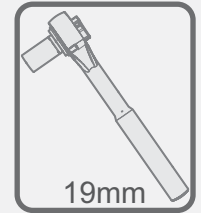

19mm

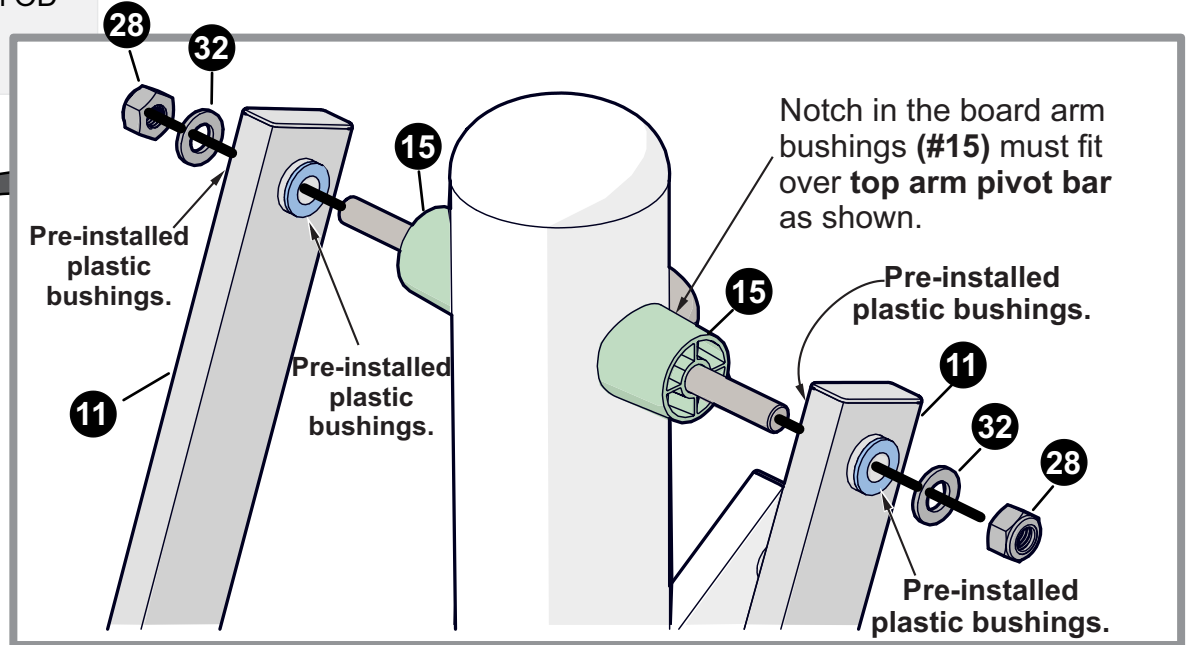
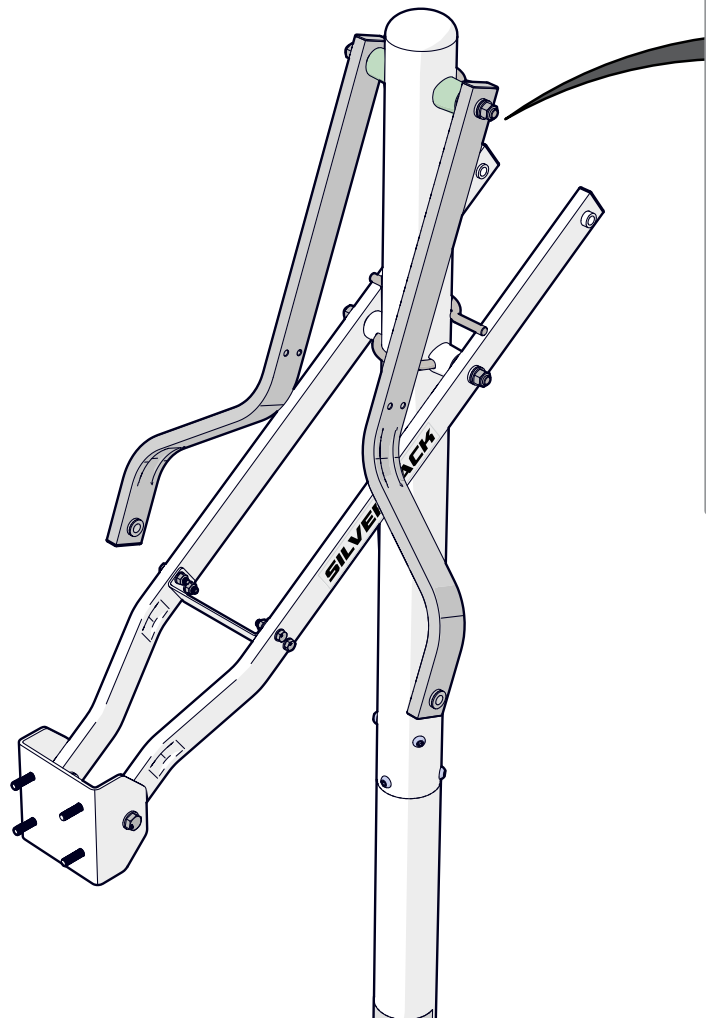

NOTE

BEFORE INSTALLING ARM MAKE SURE THAT THE PLASTIC BUSHINGS ARE PRE-INSTALLED IN THE METAL SLEEVE OF THE ARM AS SHOWN. IF PARTS ARE NOT PRE-ASSEMBLED OR IN THE BOX PLEASE CALL OUR CUSTOMER SERVICE DEPARTMENT.

NOTE

Tighten hardware but back off half a turn once you feel the hardware is snug.

TOOLS NEEDED

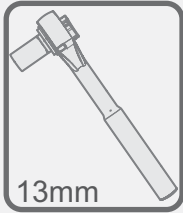
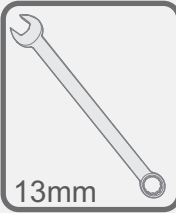

HARDWARE NEEDED (ACTUAL SIZE)

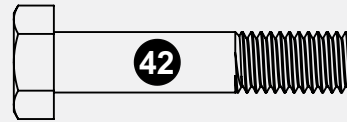

M8-1.25 X 40 HHCS ZINC
1B-7176-00
QTY. 4

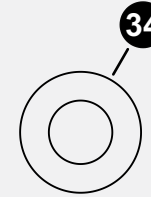

WASHER M8
2B-6797-00
QTY. 8

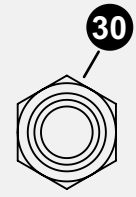

M8-1.25 HEX LOCKNUT
2B-6808-00
QTY. 4

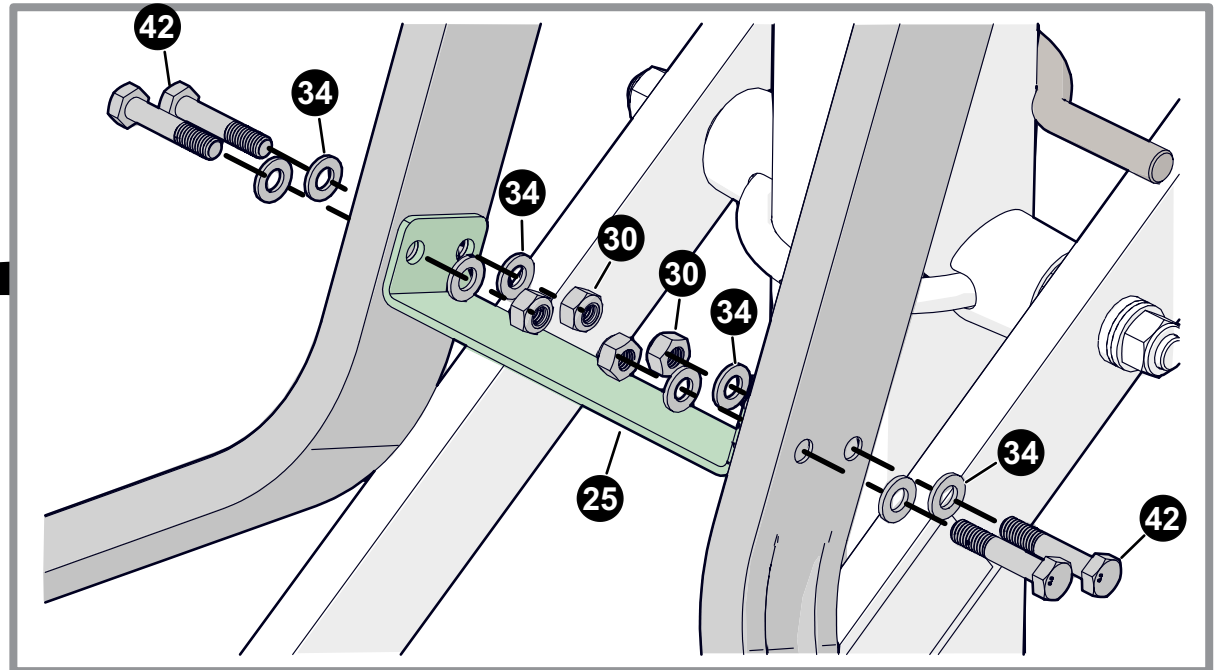
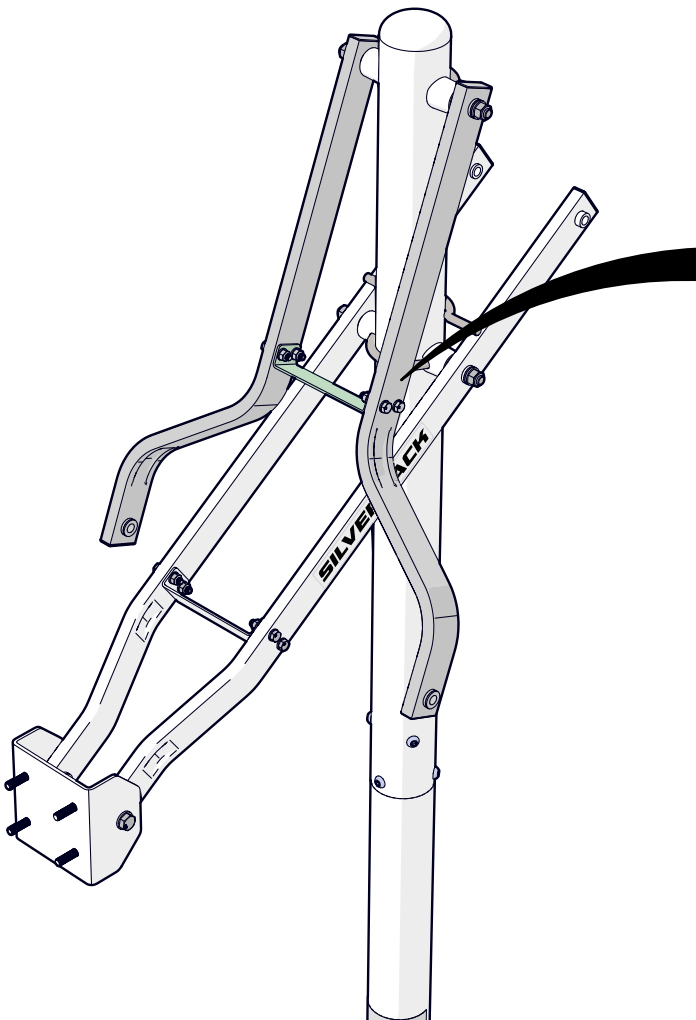

NOTE

Tighten hardware about 3/4ths of the way. Leave loose enough to attach the top arms to the backboard on page 34.

HARDWARE NEEDED (ACTUAL SIZE)

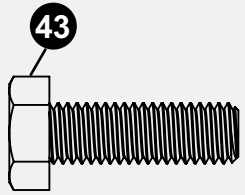

M8-1.25 X 25 HHCS
1B-7170-00
QTY. 4

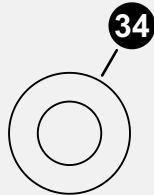

WASHER M8
2B-6797-00
QTY. 8

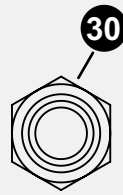

M8-1.25 HEX LOCKNUT
2B-6808-00
QTY. 4

TOOLS NEEDED

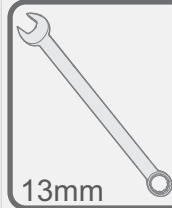

13mm



13mm

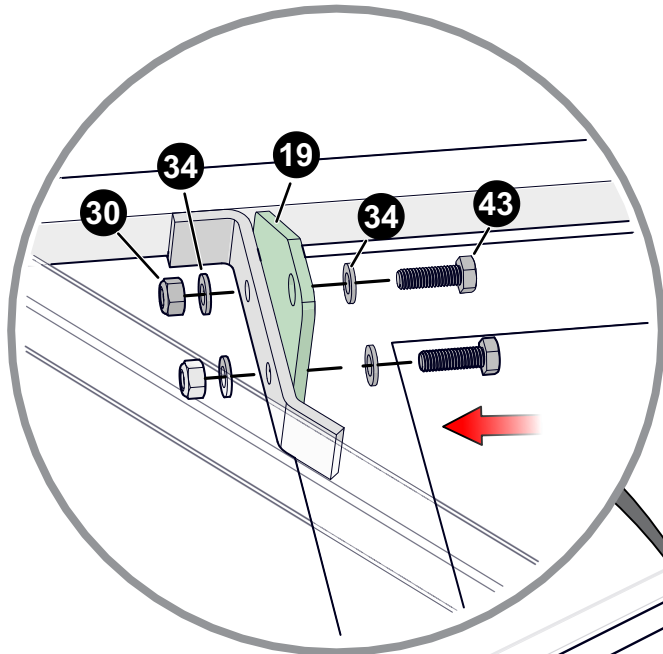

NOTE
MAKE SURE HEAD OF BOLTS ARE ASSEMBLED ON THE INSIDE OF THE BRACKET AS SHOWN IN THE DETAIL VIEWS. FULLY TIGHTEN THIS HARDWARE UNTIL SECURE.

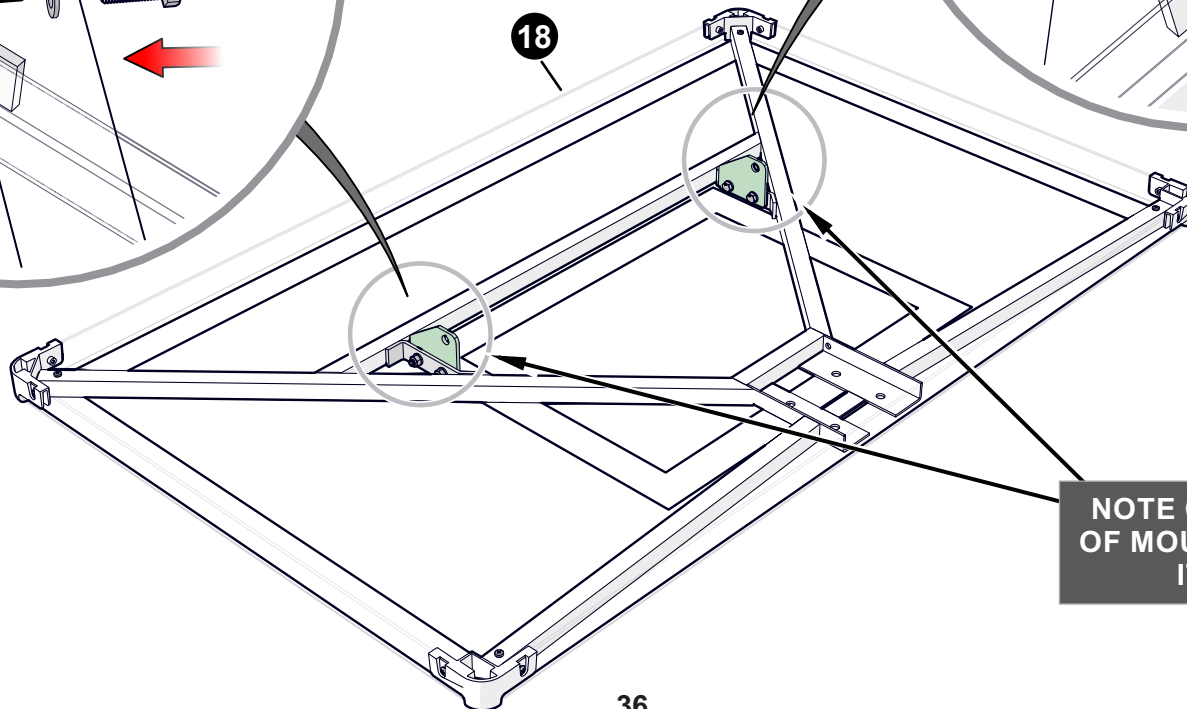
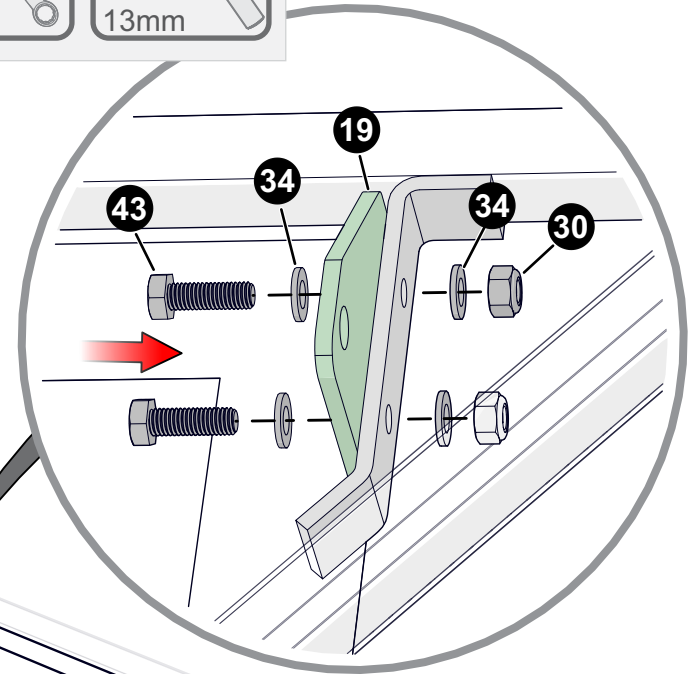

NOTE ORIENTATION OF MOUNTING PLATE ITEM #19

WARNING

USE EXTREME CAUTION WHEN STANDING ON LADDERS TO PERFORM ASSEMBLY STEPS. FOLLOW ALL WARNINGS AND CAUTIONS ON THE LADDER. FAILURE TO FOLLOW ALL THESE INSTRUCTIONS AND WARNINGS COULD LEAD TO SERIOUS PERSONAL INJURY OR PROPERTY DAMAGE.

NOTE

SLIDE BACKBOARD ONTO THREADED STUDS EXTENDING FROM BACKBOARD MOUNTING CHANNEL. HOLD IN PLACE WHILE HELPER COMPLETES NEXT STEP.

THE FOLLOWING STEPS REQUIRE 2 PEOPLE.

TOOLS NEEDED

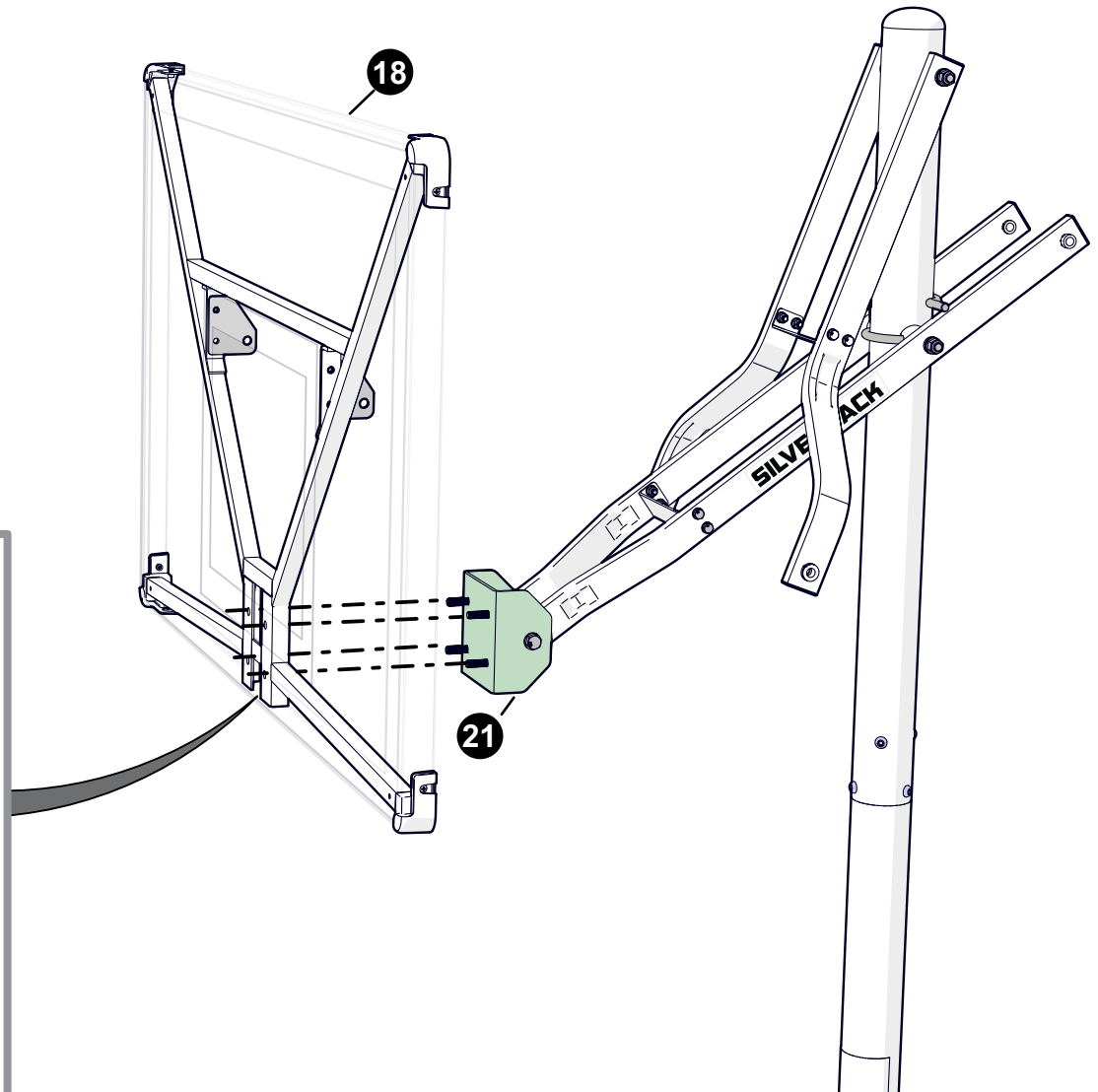
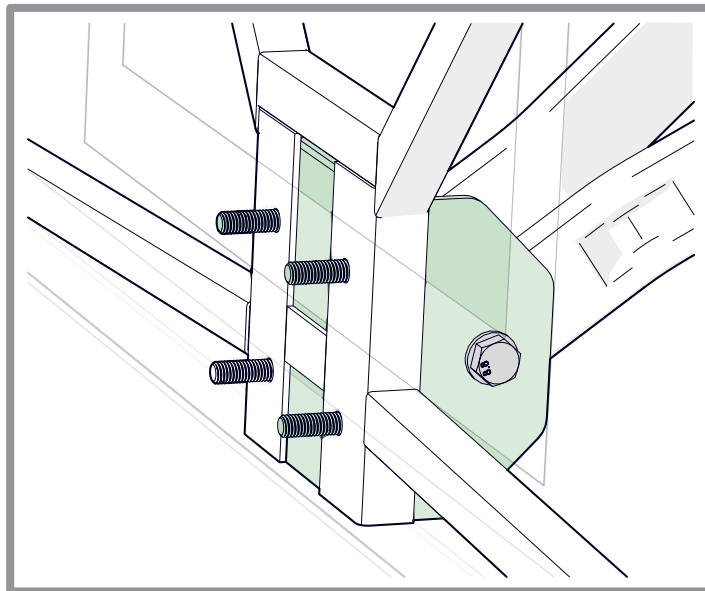

TOOLS NEEDED

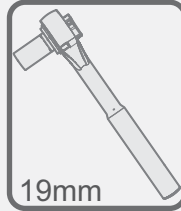
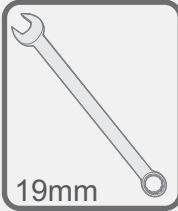

HARDWARE NEEDED (ACTUAL SIZE)

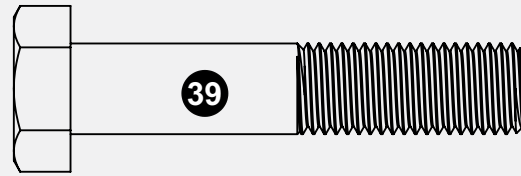

M12-1.75 X 60mm HEX HEAD BOLT
1B-7174-00
QTY. 2

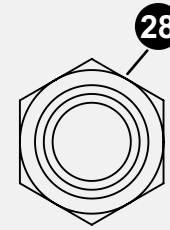

M12-1.75 HEX LOCK NUT
2B-6805-00
QTY. 2

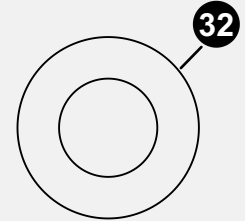

WASHER M12 X 24mm OD
2B-6804-00
QTY. 4

THE FOLLOWING STEPS REQUIRE 2 PEOPLE.

NOTE

WHILE SOME ONE IS HOLDING THE BACKBOARD IN PLACE
HAVE A HELPER ASSEMBLE THE UPPER BOARD ARMS TO
BACKBOARD MOUNTING PLATES AS SHOWN.

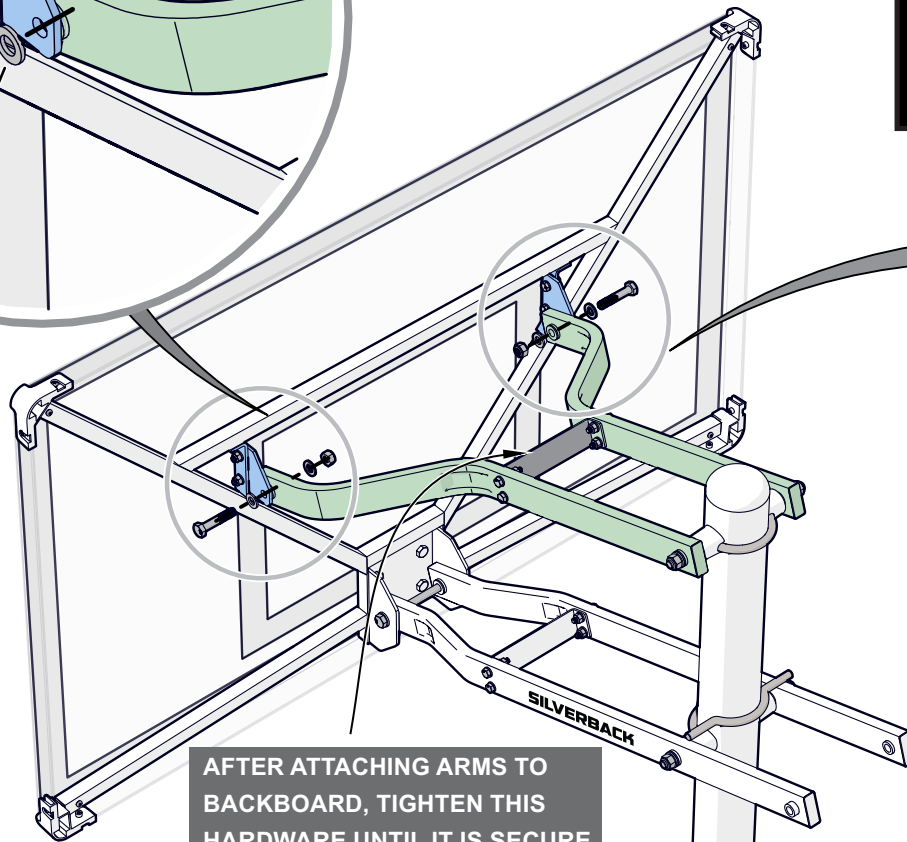
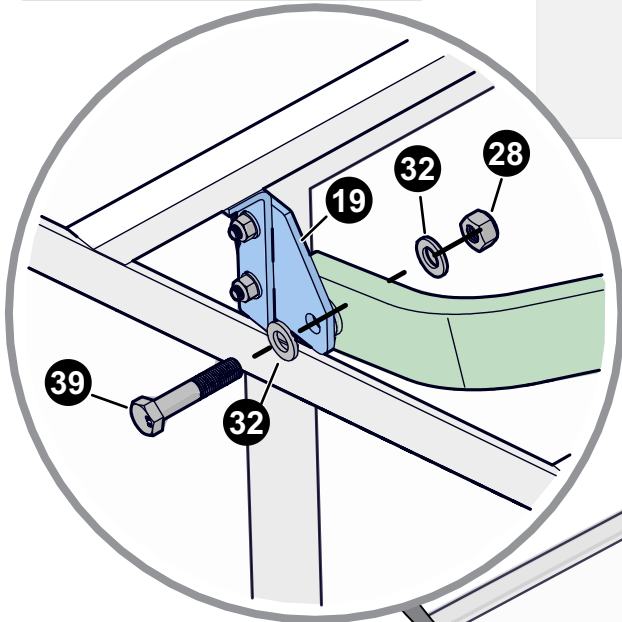

AFTER ATTACHING ARMS TO
BACKBOARD, TIGHTEN THIS
HARDWARE UNTIL IT IS SECURE,
SNUG IS TIGHT ENOUGH.

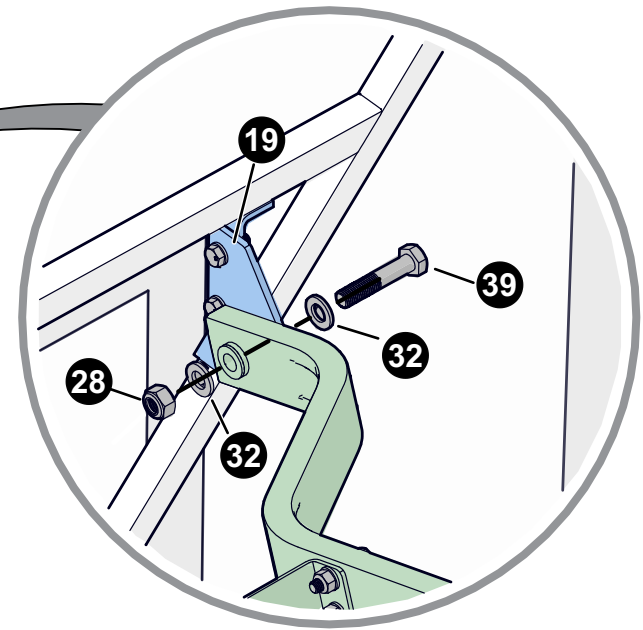

TOOLS NEEDED

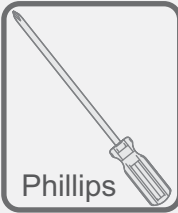

Phillips

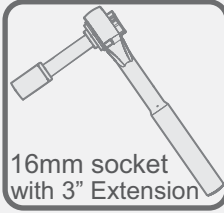

16mm socket
with 3" Extension

NOTE

TAKE PROTECTIVE COATING OFF THE
BACKBOARD BEFORE ATTACHING THE RIM.

CAUTION

NEVER USE RIM WITH COVERPLATE REMOVED!

HARDWARE NEEDED (ACTUAL SIZE)

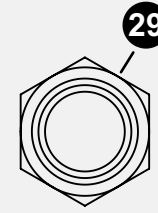

M10-1.5 HEX LOCK NUT
2B-6801-00
QTY. 4

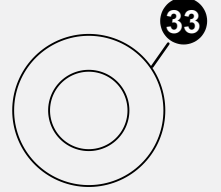

WASHER M10
2B-6800-00
QTY. 4

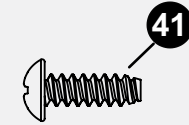

#8 X 1/2" THREAD FORMING SCREW
1B-6238-01
QTY. 4

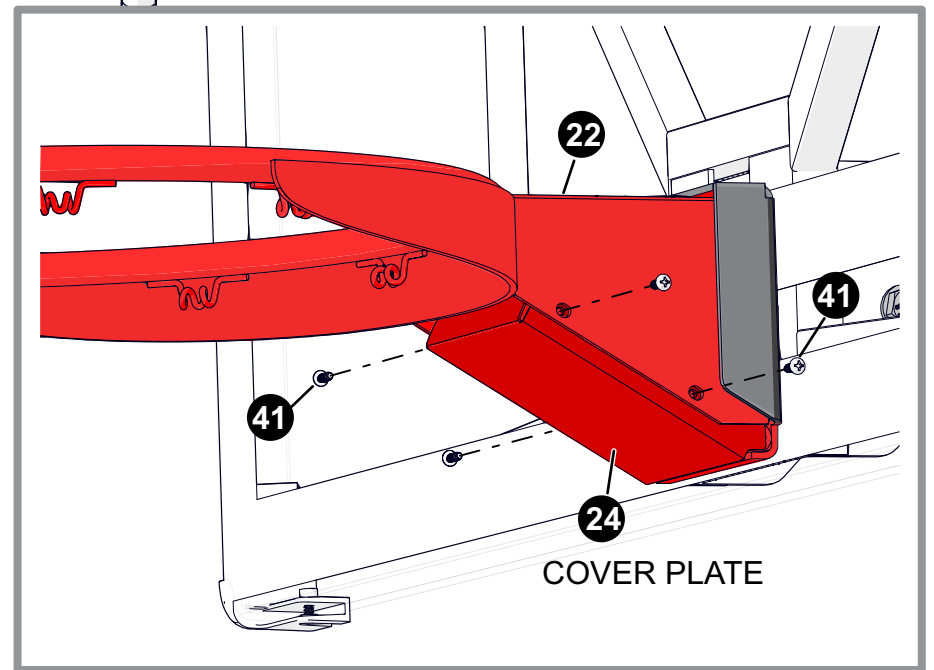
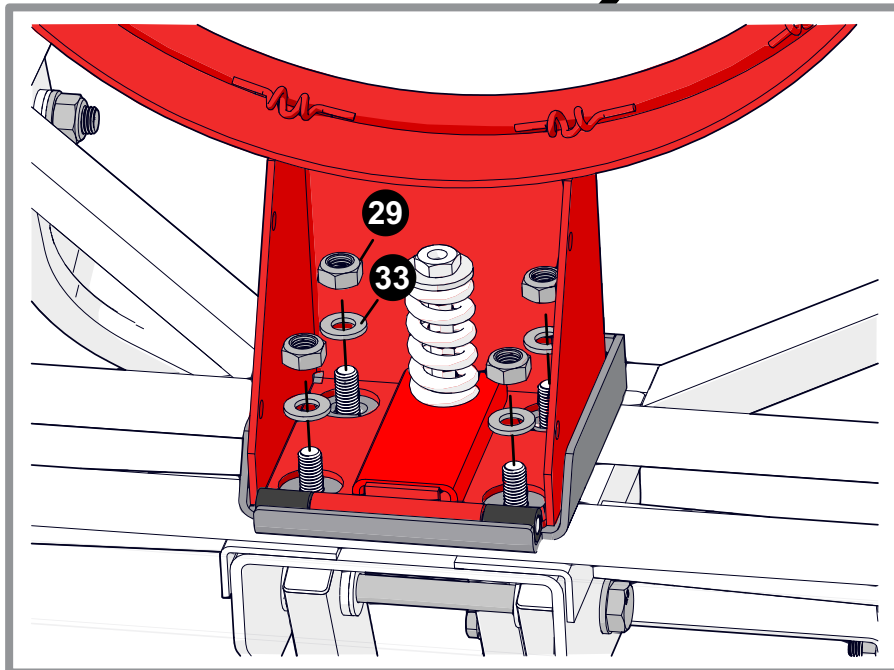
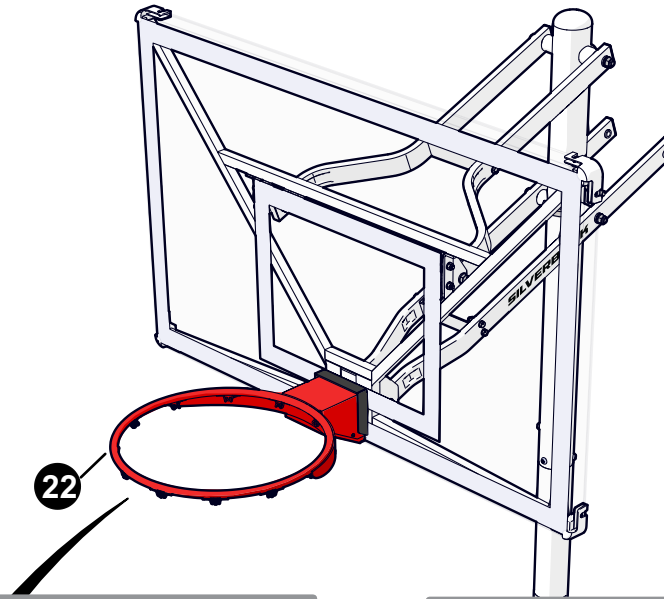

HARDWARE NEEDED (ACTUAL SIZE)

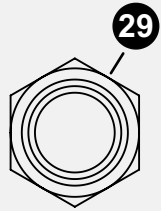

M10-1.5 HEX LOCK NUT
2B-6801-00
QTY. 2

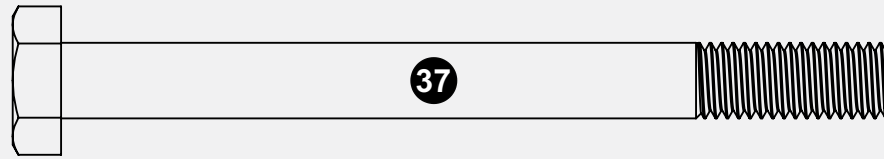

HEX HEAD BOLT M10-1.5 X 110mm
1B-7079-00
QTY. 2

TOOLS NEEDED

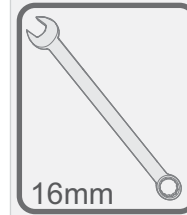

16mm

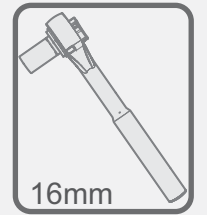

16mm

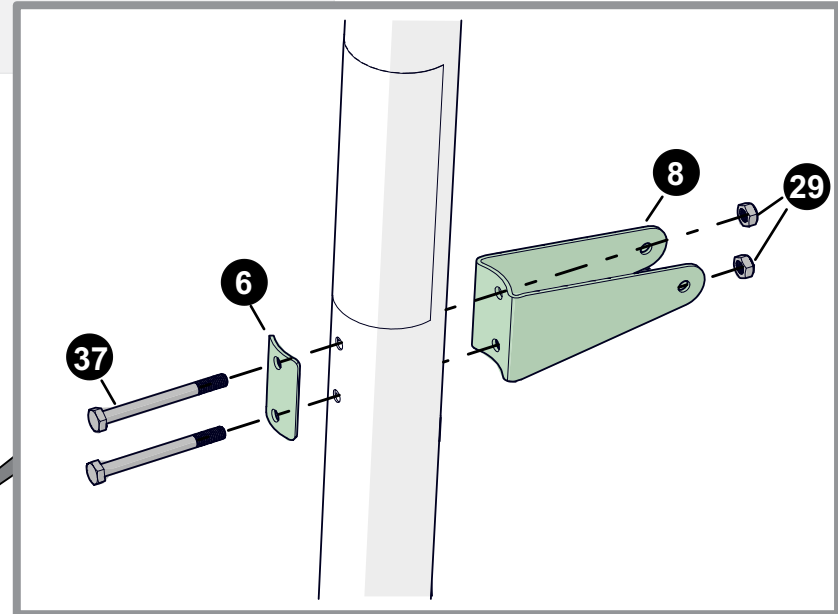
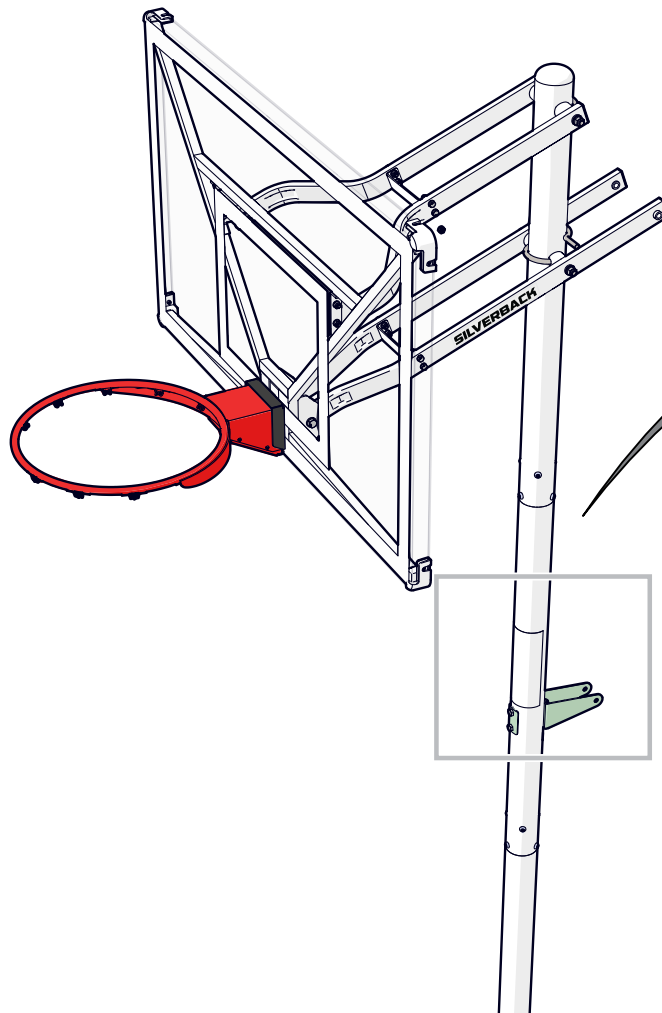

HARDWARE NEEDED (ACTUAL SIZE)

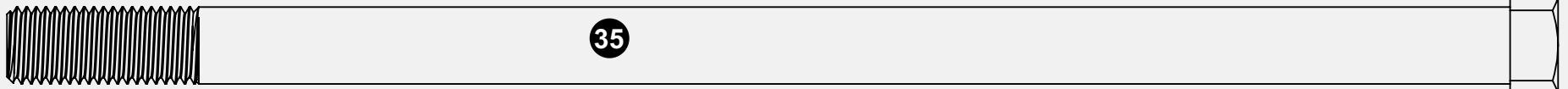

35

M12-1.75 X 235mm HEX HEAD BOLT
1B-7177-00
QTY. 1

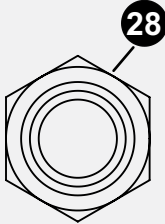

28

M12-1.75 HEX LOCK NUT
2B-6805-00
QTY. 1

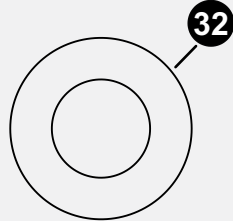

32

WASHER M12 X 24mm OD
2B-6804-00
QTY. 2

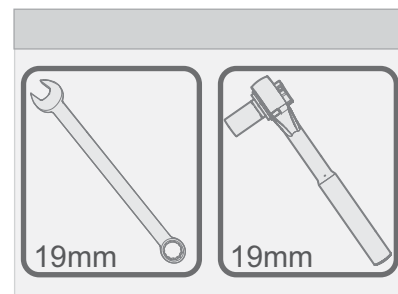
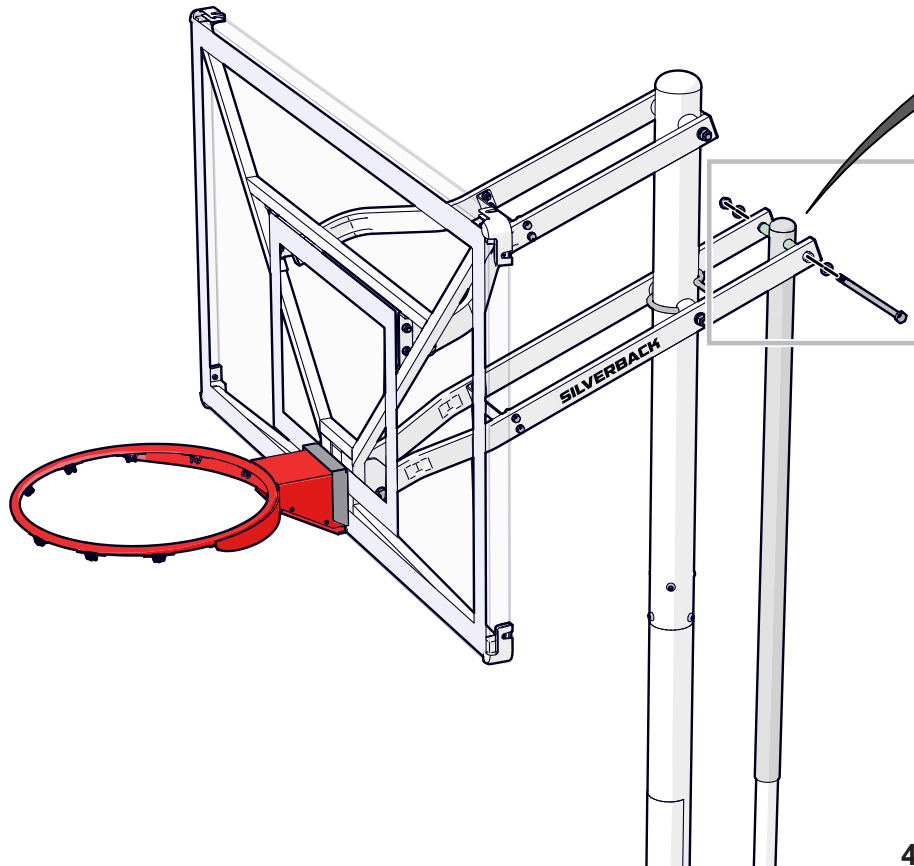
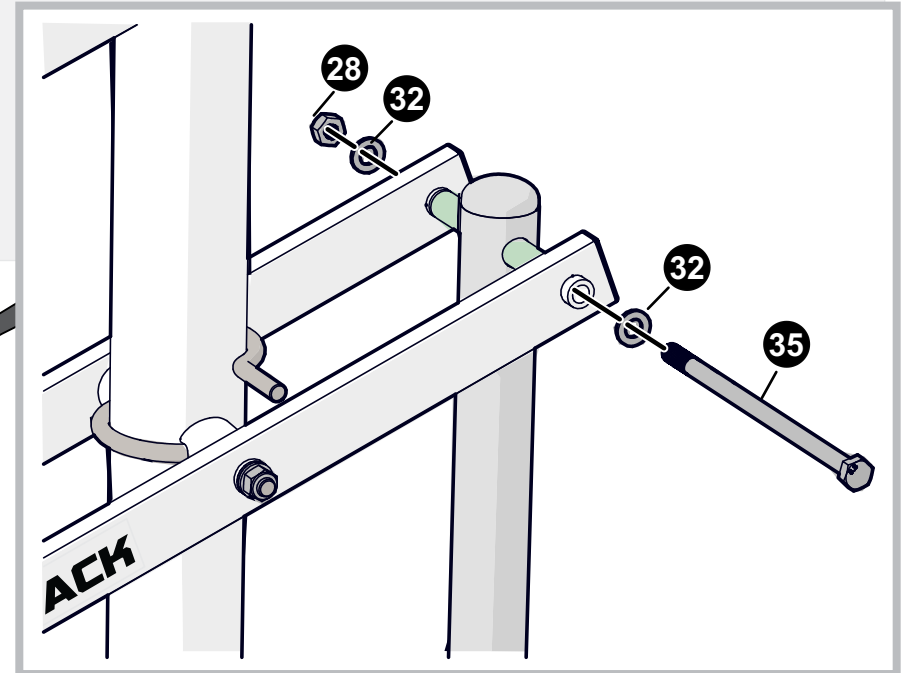

19mm

19mm

NOTE

WHEN ATTACHING ACTUATOR TO
LOWER BOARD ARMS MAKE
SURE THE HARDWARE IS SNUG.

NOTE

IF NEEDED ATTACH THE HANDLE (#17) WITH PIN (#16) AND ROTATE THE ACTUATOR UNTIL IT IS EXTENDED TO THE MAXIMUM HEIGHT AND SO THAT THE BOTTOM HOLES IN THE ACTUATOR LINE UP WITH THE ACTUATOR BRACKETS (#8).

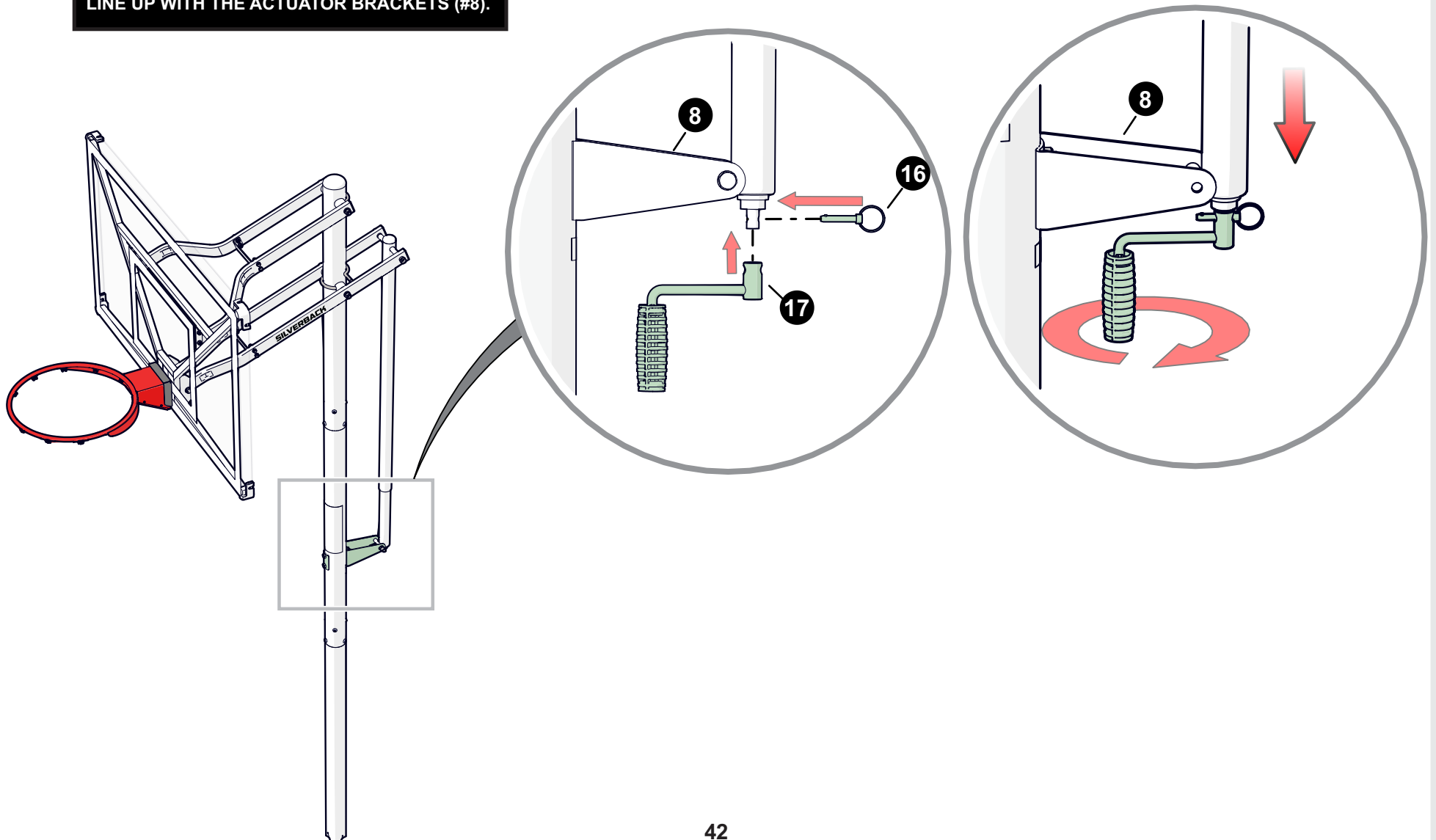

HARDWARE NEEDED (ACTUAL SIZE)

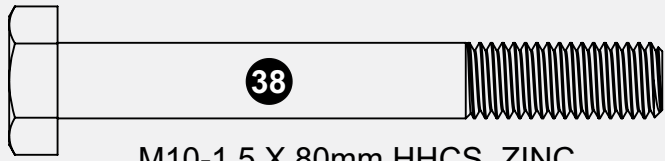

M10-1.5 X 80mm HHCS, ZINC
1B-7179-00
QTY. 1

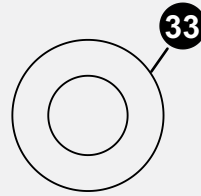

WASHER M10
2B-6800-00
QTY. 2



M10-1.5 HEX NUT, PROTECTIVE CAP
2B-6799-00
QTY. 1

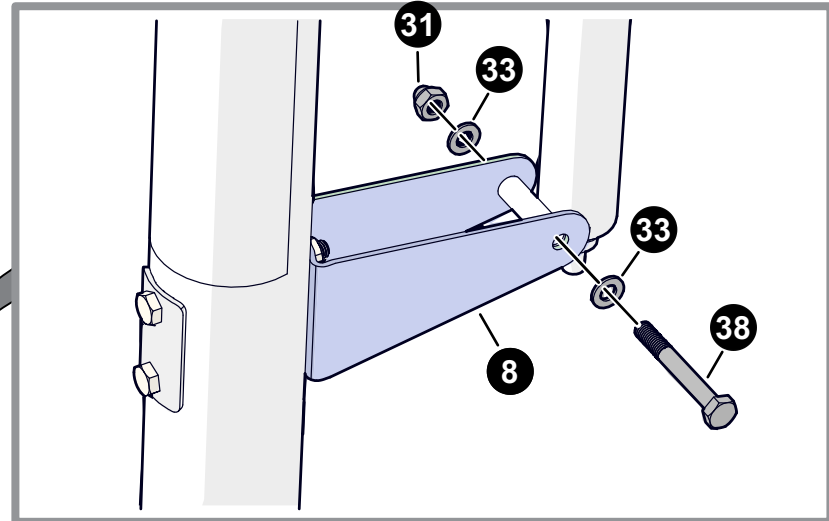
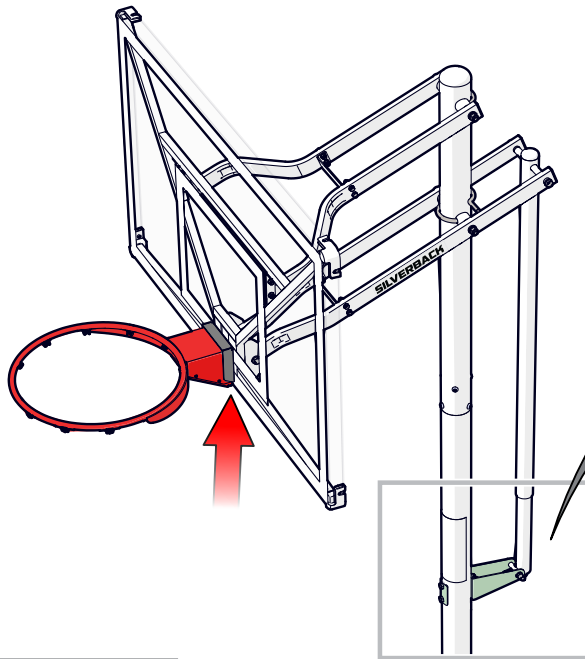

NOTE

IT MAY BE NECESSARY TO HAVE A SECOND PERSON PUSH UP ON THE BACKBOARD SO THAT THE HOLES IN THE BOTTOM OF ACTUATOR LINE UP WITH THE HOLES IN THE POST BRACKETS (# 8). DO NOT OVER-TIGHTEN WHEN ATTACHING BOTTOM OF ACTUATOR TO ACTUATOR BRACKET. ACTUATOR MUST BE ABLE TO PIVOT FREELY.

TOOLS NEEDED

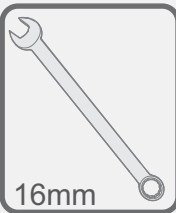

16mm

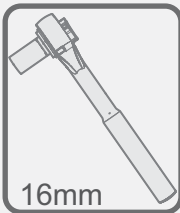

16mm

NOTE

IF NOT ALREADY INSTALLED, ATTACH
HANDLE AT THIS TIME.

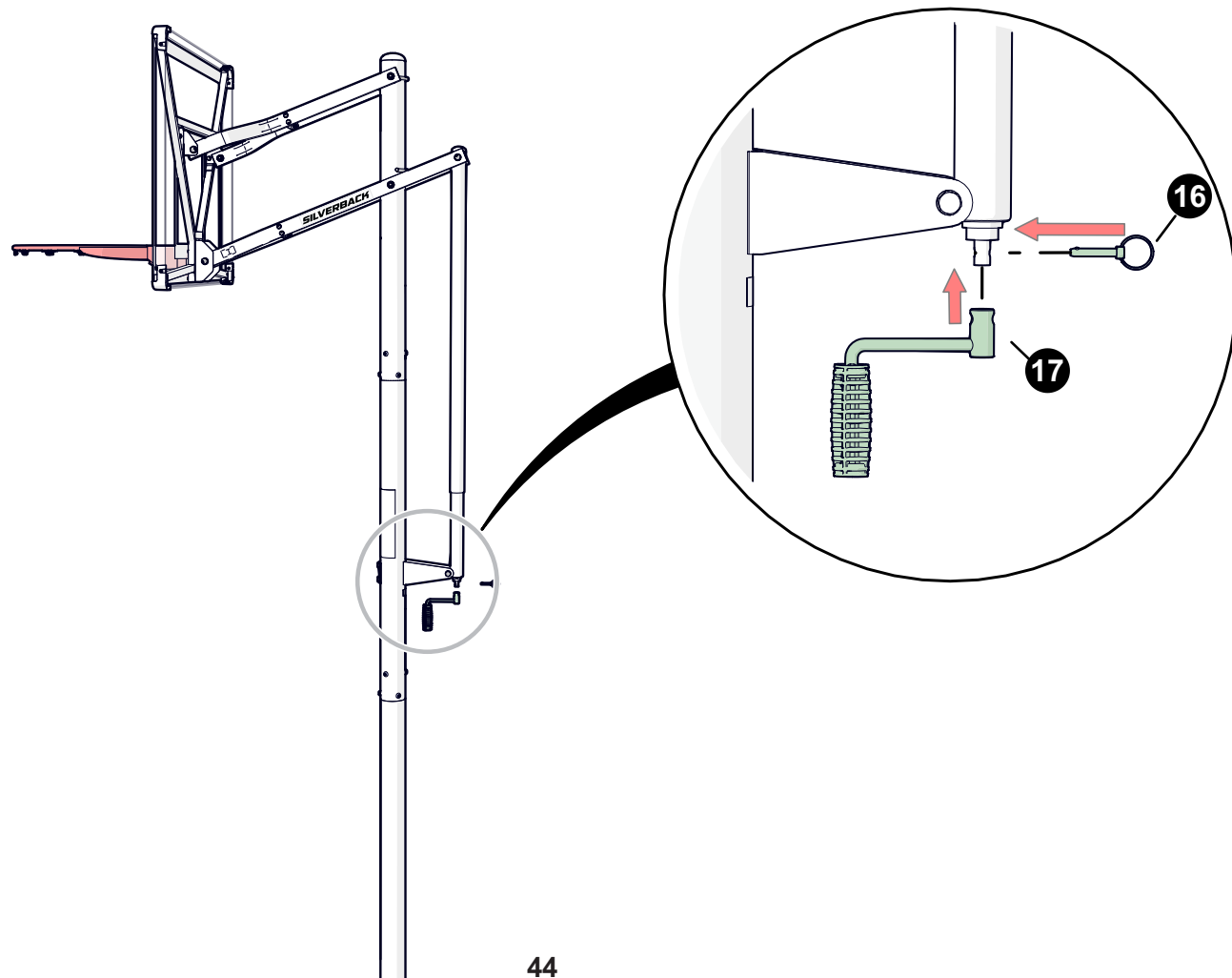

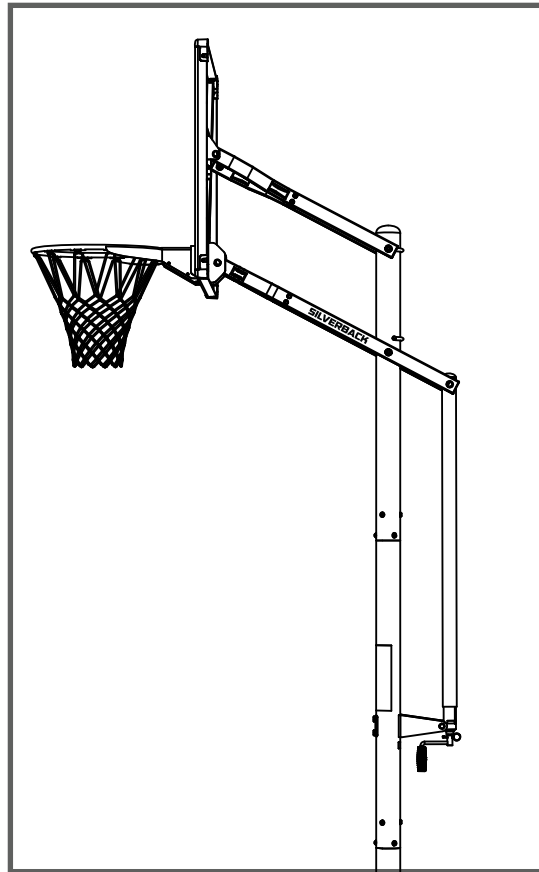
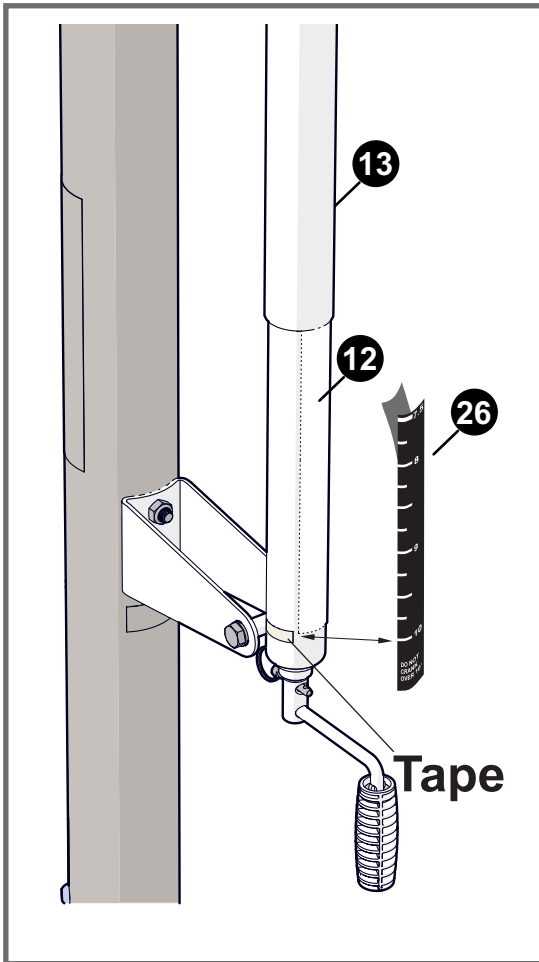

SET AT 10 FEET HIGH

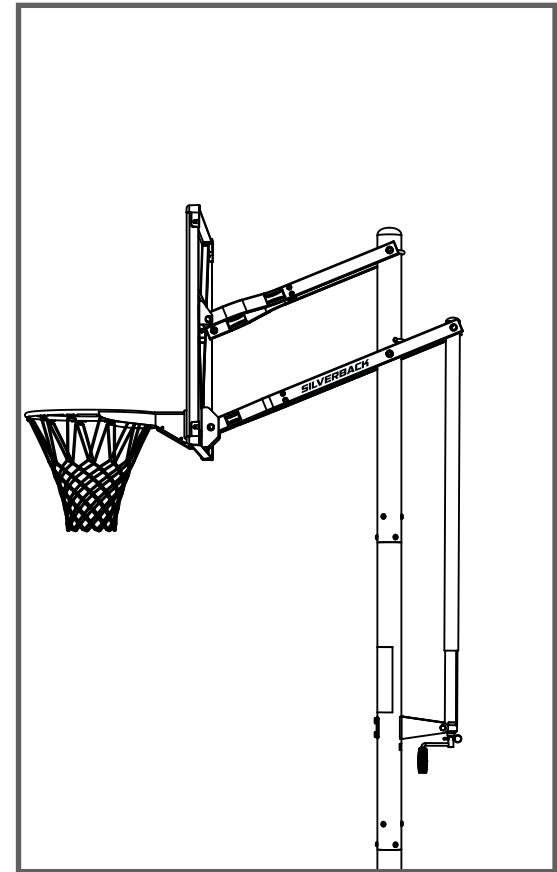

LOWER ALL THE WAY DOWN

Raise Backboard to 10 FT. regulation playing height. Measure from top of rim straight down to the playing surface.

Using tape - mark the side of the steel actuator (#12) just under the plastic actuator sleeve (#13) at this 10 ft rim height. See **Figure 1**.

Lower backboard all the way down. Do not force actuator once backboard is in its lowest position. See **Figure 2**.

Do not remove adhesive backing from height decal (#26) yet. Carefully place height decal on backside of steel actuator and line up the 10 ft mark on the tape with the 10 ft mark on the height decal. Decal should fit correctly onto the backside of the steel actuator. (If not, simply trim to fit the top of the actuator decal).

DETAIL A

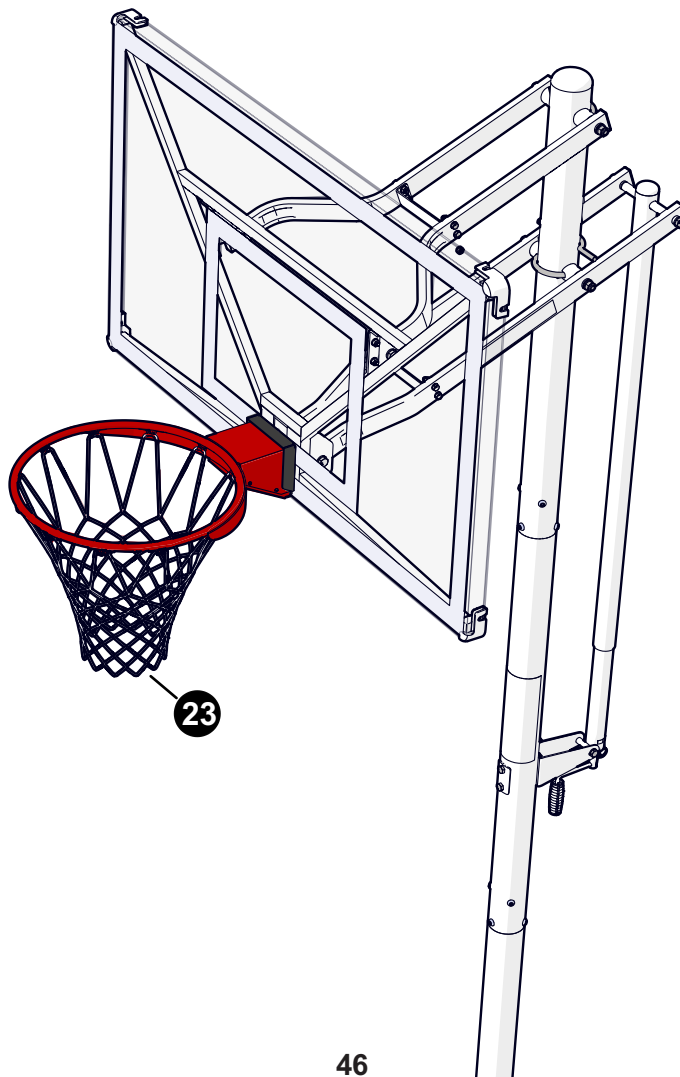
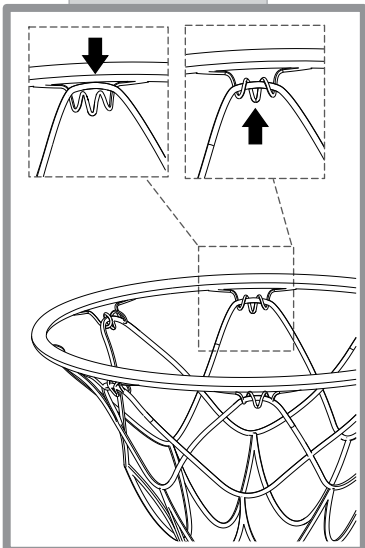

CARE INFORMATION

BACKBOARD CARE AND MAINTENANCE

Items needed to clean backboard:

- 100% cotton soft cloth, (only)
- Mild dish washing liquid for soap
- Luke warm water
- Mild plastic polish to minimize scratches

Rinse backboard with lukewarm water. Wash gently with a **100% Cotton** soft cloth, lukewarm water and **mild** soap. Do not scrub. Rinse backboard with lukewarm water again. Dry with **100% Cotton** soft cloth. To minimize scratches and minor abrasions to your backboard, apply a **mild** polish such as Johnson's Paste Wax, Novus Plastic Polish # 1 or Mirror Glaze Plastic Polish. Strong cleansers will damage backboard and void warranty.

RIM

Do not dunk or hang from the rim or any part of this system.

Rims are not warranted for any defects other than workmanship. Torn back plates, damaged springs, bent rings, damaged eye bolts, and torn or distorted rim supports result from hanging on the rim and are not warranted.

The goal should not be cranked over 10'. Adjustments of the goal should be done under adult supervision.

Wear a mouth guard when playing to avoid dental injuries.

MAINTENANCE

To ensure ease of operation, lubricate all pivot points at least every 6 months or as needed with a good lubricant such as WD-40.

RUST

Inspect your pole periodically, if rust should appear, remove loose paint, sand lightly, primer and paint with exterior flat matte finish enamel paint.

LIMITED 5 YEAR WARRANTY

This consumer warranty extends to the original consumer purchase of any Escalade® Sports Product (hereinafter referred to as the "Product").

WARRANTY COVERAGE: Escalade® Sports warrants to the original Consumer Purchaser that any Product of its manufacture is free from defects in material and workmanship. THIS WARRANTY IS VOID IF THE PRODUCT HAS BEEN DAMAGED BY ACCIDENT, UNREASONABLE USE, NEGLIGENCE, IMPROPER SERVICE, FAILURE TO FOLLOW INSTRUCTIONS PROVIDED WITH THE PRODUCT OR OTHER CAUSES NOT ARISING OUT OF DEFECTS IN MATERIAL OR WORKMANSHIP.

Subject to proper installation and normal Residential use, Escalade® Sports warrants, subject to the limitations below, to the original retail purchaser all structural components of the Silverback® System to be free of defects in material and workmanship for a period of five (5) years from the original purchase.

Merchandise must be shipped prepaid with a copy of proof of purchase to Escalade® Sports factory for examination to determine if the basketball system needs to be repaired or replaced. Any labor costs, travel expenses and any other changes involved in the removal, installation or replacement of the defective/repared parts from/to your Silverback® System will be the purchaser's responsibility. Shipping charges for replaced or warranted merchandise sent back to the customer from Escalade® Sports factory must be prepaid by the customer in advance. If not, the replacement shipment will be sent out collect.

Escalade® Sports reserves the right to examine photographs or physical evidence of merchandise claimed to be defective, and to recover said merchandise, prior to authorization of warranty claims. A "Returned Goods Authorization" number may be required, please call for details prior to the return of any photographs or merchandise.

This limited 5 year warranty is expressly in lieu of all warranties, expressed or implied, including warranties of merchantability or fitness for use. Escalade® Sports does not assume or authorize any person or representative to assume for us, any other liability in connection with the sale of our products.

The remedy of repair or replacement stated above is Escalade® Sports exclusive remedy. Escalade® Sports will not be liable for any other damages or expenses which may incur, including but not limited to incidental or consequential damages. Escalade® Sports assumes no other obligations or liability on the part of the purchaser, and Escalade® Sports neither assumes nor authorizes any other person to assume for it any other liability in connection with the goods sold.

This warranty shall not apply in any manner to parts or accessories not manufactured by Escalade® Sports.

NOT COVERED BY THIS WARRANTY

- Merchandise not intended to be in places of public assembly, such as, but not limited to, schools, parks, public or private recreational facilities.
- Any merchandise subjected to Non-residential abuse, negligence, improper installation, vandalism, acts of God, alteration of product, or any other events beyond the control of Escalade® Sports.
- Paint or rusted parts. If rust should appear, remove loose paint, sand lightly, primer and paint with exterior flat matte finish enamel paint.
- HANGING ON RIM WILL VOID THE WARRANTY: Rims are not warranted for any defects other than workmanship. Torn back plates, damaged springs, bent rings, damaged eyebolts, and torn or distorted rim supports result from hanging on the rim and are not warranted.
- Shipping charges both ways. Note: Any merchandise shipped to Escalade® Sports collect will be refused.
- Dealer service charges, labor charges and travel expenses associated with replacement of repair of warranty item.

WARRANTY DISCLAIMERS: ANY IMPLIED WARRANTIES ARISING OUT OF THIS SALE, INCLUDING BUT NOT LIMITED TO THE IMPLIED WARRANTIES OF MERCHANTABILITY AND FITNESS FOR A PARTICULAR PURPOSE, ARE LIMITED IN DURATION. ESCALADE® SPORTS SHALL NOT BE LIABLE FOR LOSS OF USE OF THE PRODUCT OR OTHER CONSEQUENTIAL OR INCIDENTAL COSTS. EXPENSES OR DAMAGES INCURRED BY THE CONSUMER OF ANY OTHER USE.

Some states do not allow the exclusion or limitation of implied warranties or consequential or incidental damages, so the above limitations or exclusions may not apply to you.

LEGAL REMEDIES: This warranty gives you specific legal rights, and you may also have other rights which may vary from state to state.

WARRANTY GUIDELINES IS REQUIRED FOR ALL WARRANTY CLAIMS

1. Proof of Purchase (original retail purchaser) is required for all warranty claims.
 2. Call or write Escalade® Sports to receive a Return Authorization # and determine specific needs.
- Phone: 1-888-USA-GOAL / Warranty Dept.
Or Write Escalade® Sports at: Escalade® Sports - P.O. Box 889, Evansville, IN 47706 - Attn: Warranty Dept.
Or E-mail us at: basketball@escaladesports.com