

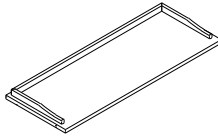

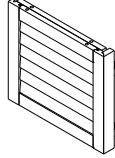

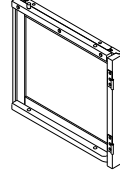

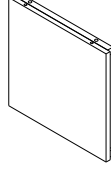
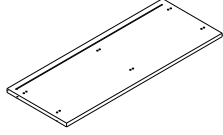
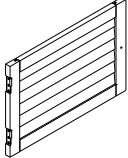
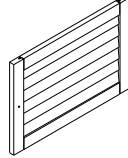
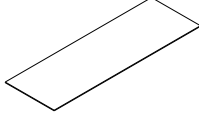
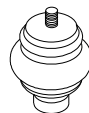

ASSEMBLY INSTRUCTION

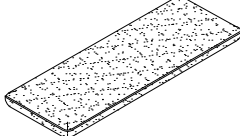
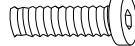
SHOES BENCH WITH CUSHION

<p>A Top Panel</p>  <p>1PC</p>	<p>B Lsf Side Frame</p>  <p>1PC</p>	<p>C Rsf Side Frame</p>  <p>1PC</p>	<p>D Middle Panel</p>  <p>1PC</p>
<p>E Bottom Panel</p>  <p>1PC</p>	<p>F Lsf Door</p>  <p>1PC</p>	<p>G Rsf Door</p>  <p>1PC</p>	<p>H Back Panel</p>  <p>1PC</p>
<p>I Bun Foot</p>  <p>4PCS</p>	<p>J Middle Leg</p>  <p>1PC</p>	<p>K Seat Cushion</p>  <p>1PC</p>	<p>L Bolt Ø1/4"x1-3/8"mm</p>  <p>12PCS</p>
<p>M Spring Washer Ø1/4"x10mm</p>  <p>12PCS</p>	<p>N Flat Washer Ø1/4"x16mm</p>  <p>12PCS</p>	<p>O Knob</p>  <p>2PCS</p>	<p>P Machine Screw Ø5/32"x7/8"mm</p>  <p>2PCS</p>
<p>Q Magnet 46x16x14mm</p>  <p>2PCS</p>	<p>R Wood Screw Ø3x14mm</p>  <p>4PCS</p>	<p>S Allen Key Ø1/4"</p>  <p>1PC</p>	<p>T Wood Dowel Ø8x30mm</p>  <p>12PCS</p>

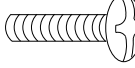
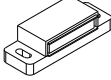
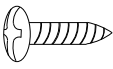

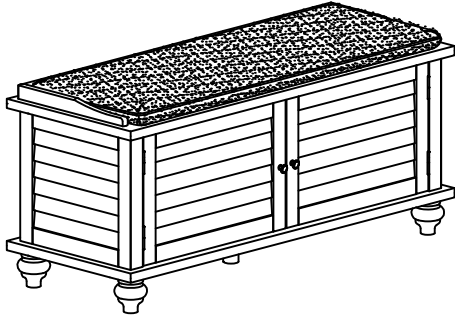
This above page lists all the contents included in the box. Please take the time to identify the hardware as well as the individual components to this product. As you unpack and prepare for assembly. Place the contents on a carpeted or padded area to protect them from damage.

1 Attach Bun Foot (I) and Middle Leg (J) to Bottom Panel (E) until they are tight.

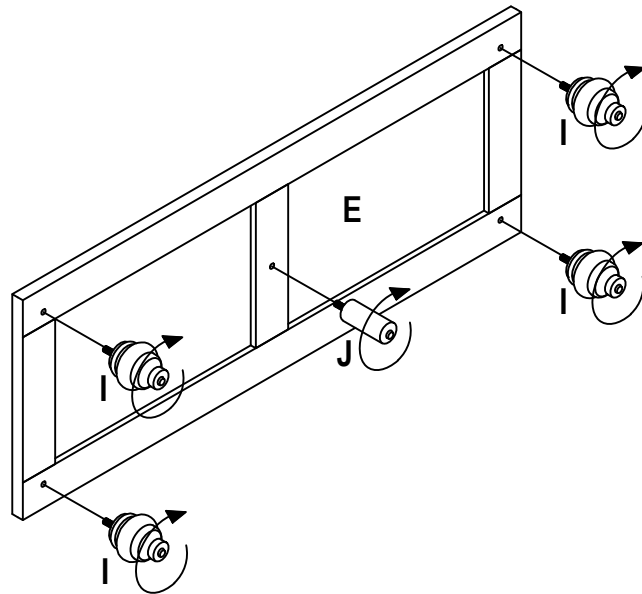

- 2** Attach Lsf Side Frame (B), Rsf Side Frame (C) and Middle Panel (D) to Bottom Panel (E) by Wood Dowel (T), Flat Washer (N), Spring Washer (M) and Bolt (L) with Allen Key (S).

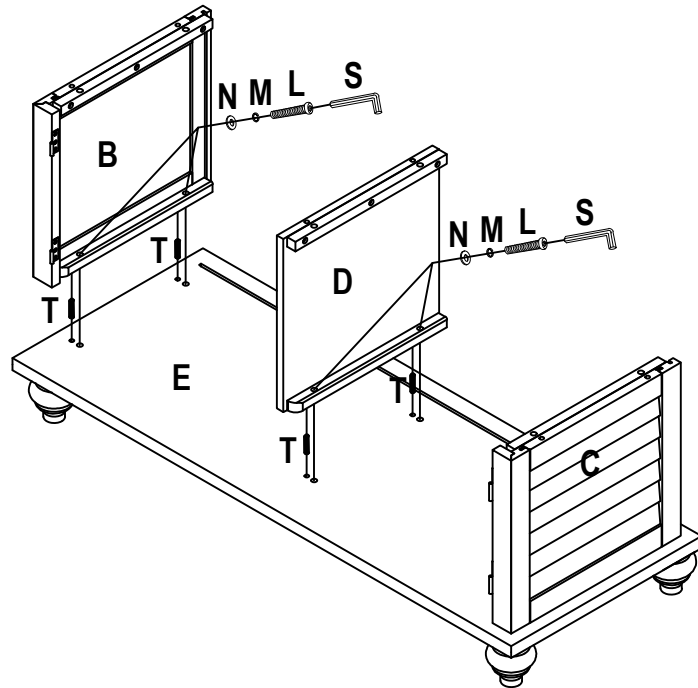

- 3** Insert Back Panel (H) into Bottom Panel (E).

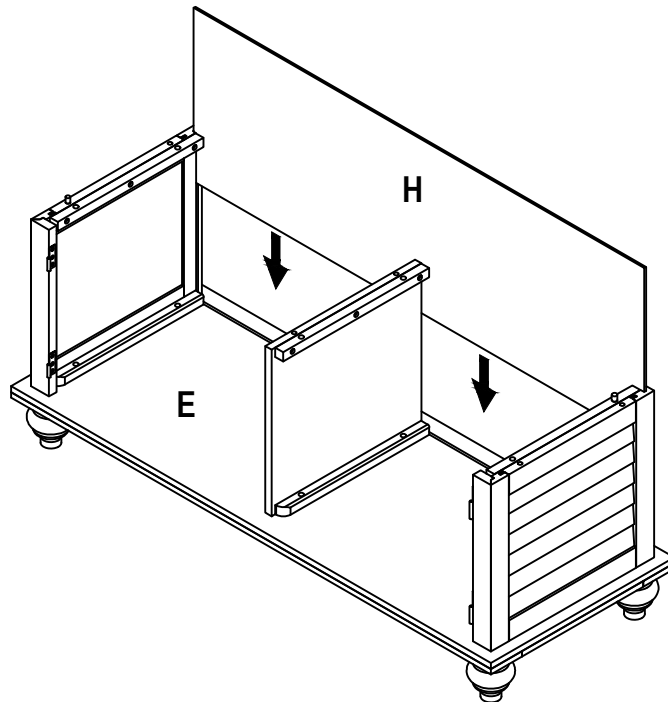

- 4** Attach Knob (O) to Lsf Door (F) and Rsf Door (G) by using Machine Screw (P) and then attach Lsf Door (F) and Rsf Door (G) to Lsf Side Frame (B) and Rsf Side Frame (C) by using pre-assembled hinger as drawing below.

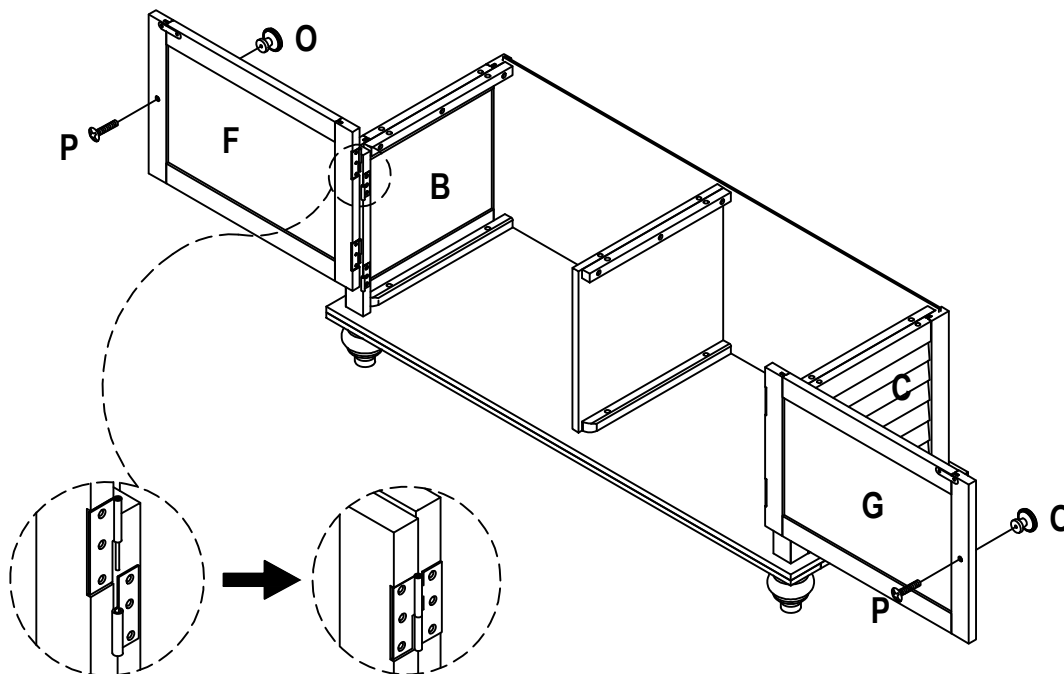

- 5** Attach Magnet (Q) to Top Panel (A) by using Wood Screw (R).

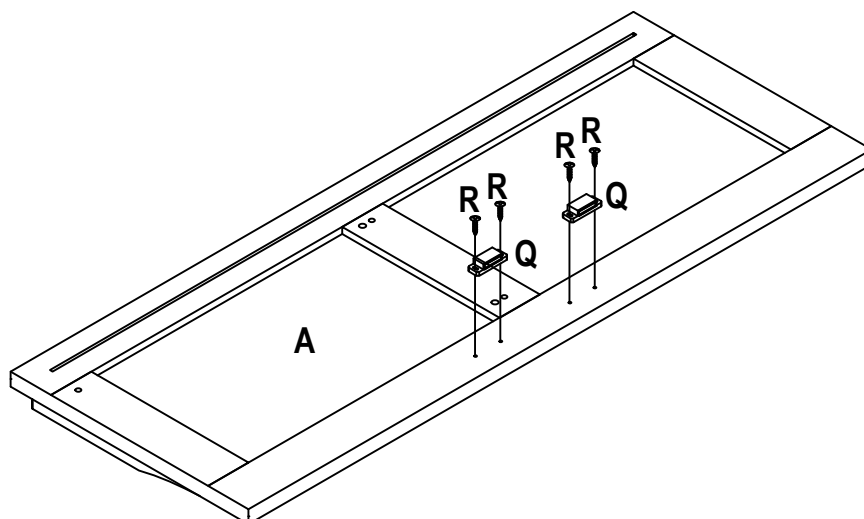

- 6** Attach Top Panel (A) to assembled Side Frame (B & C) and Middle Panel (D) by using Wood Dowel (T), Spring Washer (M), Flat Washer (N) and Bolt (L) with Allen Key (S) as drawing below.

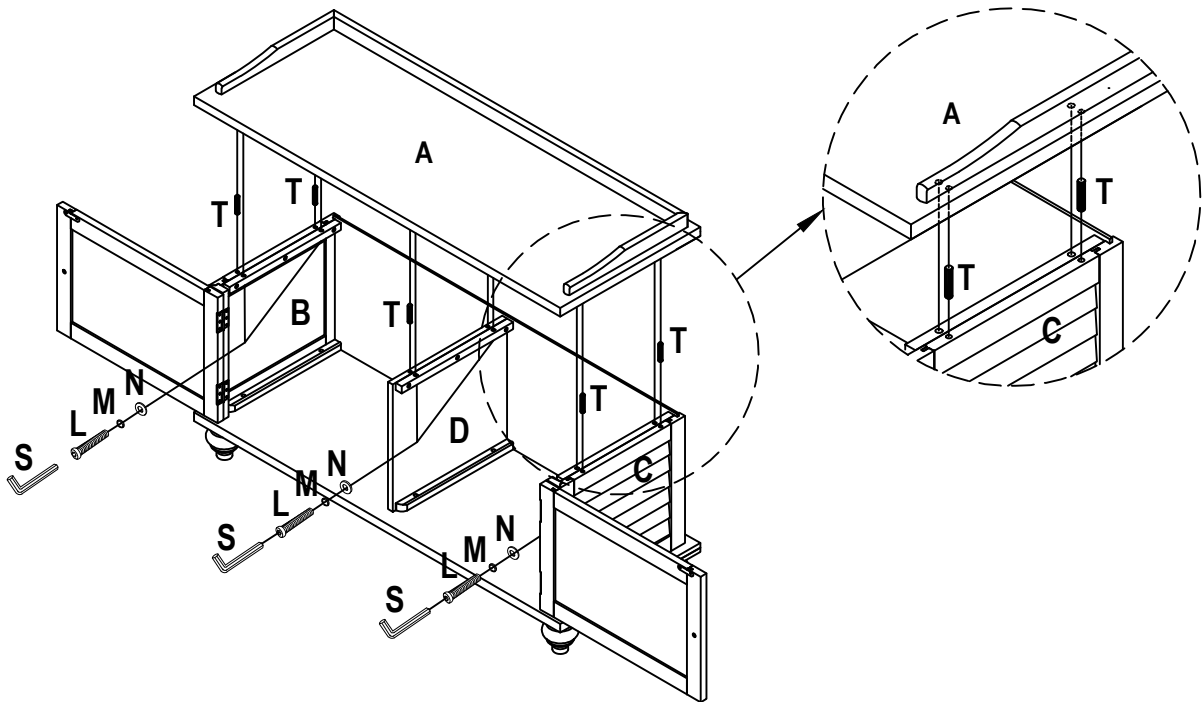

- 7** Put Seat Cushion (K) into Top Panel (A) as drawing below and then adjust the levelers on the bottom of the Middle Leg (J) to keep the level.

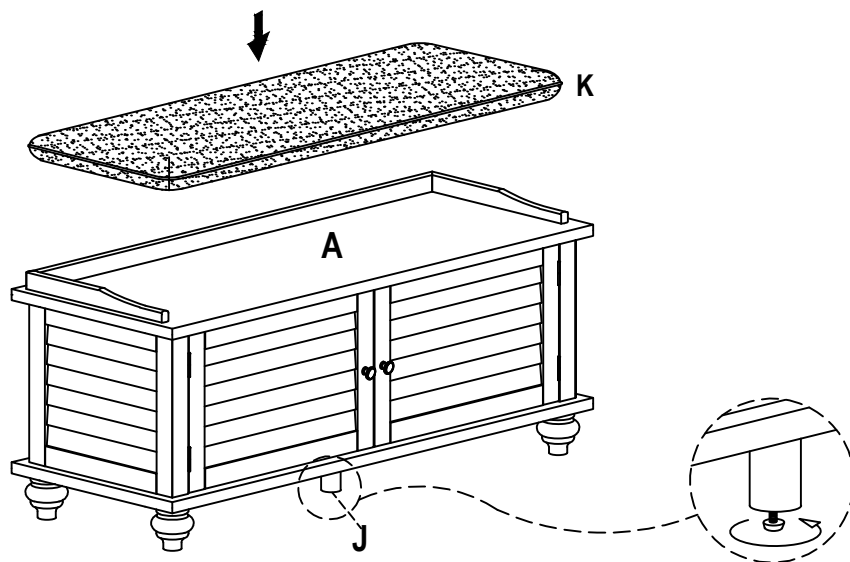

Cleaning & Care

Treat surface with care. Surface is resistant to scratches but is not scratch resistant. Clean surfaces with a dry or damp soft cloth. Do not use abrasive cleaners. Hardware may loosen over time. Periodically check that all connections are tight.