

WALKER EDISON
TM

Flynn 70" TV stand

SKU# WEFLN21704

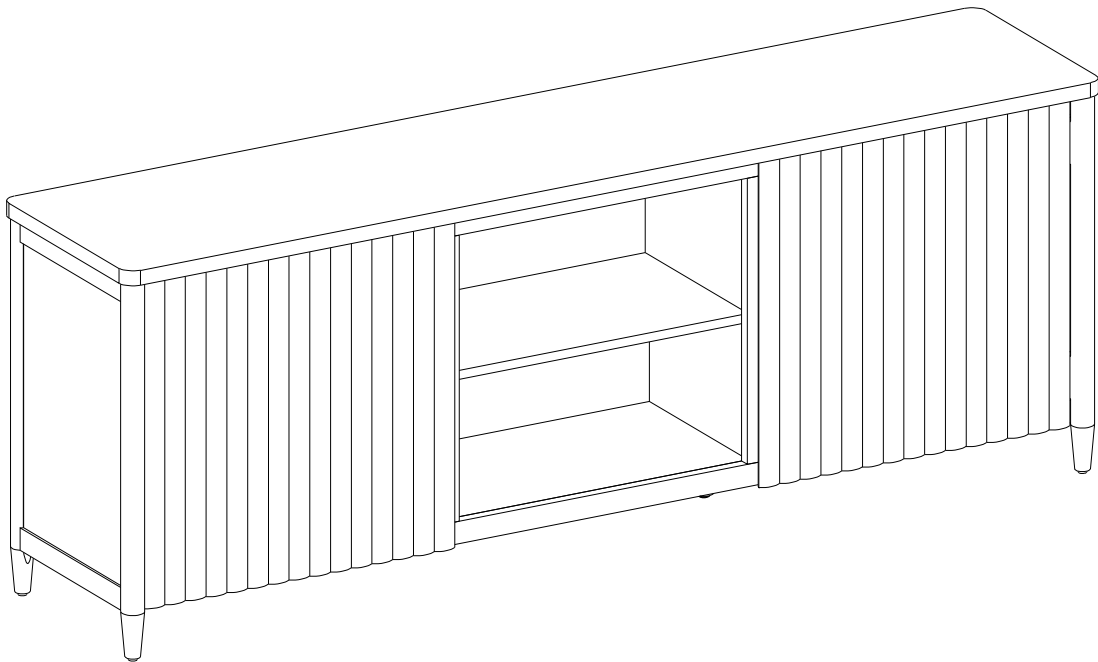

For Residential Use Only

Please visit our website for the most current instructions, assembly tips, report damage, or request parts. www.walkeredison.com



Time to get started

Set up a clean and soft workplace to get started and avoid damage during the assembly. It also helps to double-check that you've got all the pieces and parts before diving in to assembly.

Estimated time for assembly

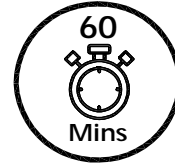

People recommended for assembly

Make it a team effort! Grab a friend for quicker, easier assembly.

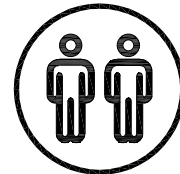

2 People Build

Tools Needed

Grab a Phillips head screwdriver to conquer this assembly



Use power tools with caution

You can cause cracking or damage to the material and easily strip the hardware. If you choose to use a power tool, your product will no longer be covered under Walker Edison's warranty.

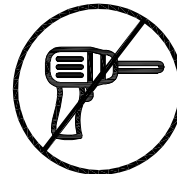

Glue is provided to secure wood dowels in place

When inserting dowels, locate the appropriate hole, place a small amount of glue in the hole, and then insert the dowel. Wipe away excess glue immediately.

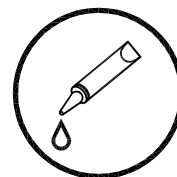

Scan to get assembly tips and help!



Parts List





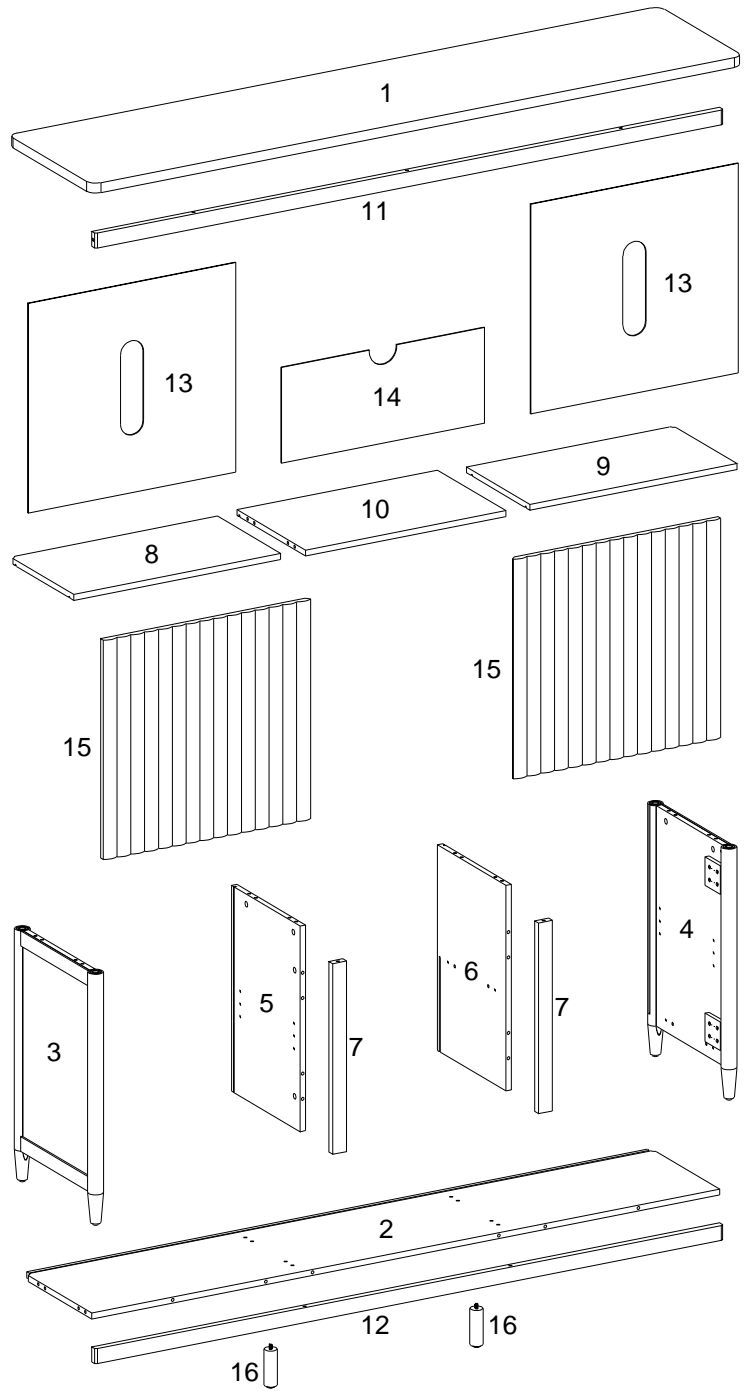

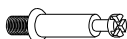

Part Number	Description	Quantity
-------------	-------------	----------

1	Top Panel	1
2	Bottom Panel	1
3	Left Side Panel	1
4	Right Side Panel	1
5	Left Middle Divider Panel	1
6	Right Middle Divider Panel	1
7	Front molding	2
8	Left Adjustable shelf	1
9	Right Adjustable shelf	1
10	Fixed divider	1
11	Front upper rail	1
12	Front bottom rail	1
13	Left / Right back panel	2
14	Middle back panel	1
15	Door panel	2
16	Middle foot	2

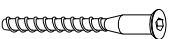

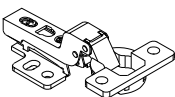



Hardware List

Part	Size	Name	Quantity
A	 8x30mm	Wooden dowel	30
B	 6x35mm	Cam bolt	29
C	 15x11mm	Cam lock	29
D	 30mm	Sticker	29
E	 6x50mm	Bolt	4
F	 M4mm	Hex Key	1
G	 35mm	Hinge	4
H	 3.5x14mm	Screw	24
J	 8x5x16mm	Shelf support pin	8
K		Plastic wedge	22
L	 3x17mm	Screw	22



Hardware List

Part	Size	Name	Quantity	
M		8x2mm	Rubber pad	4
N			Glue tube	1

*The hardware quantities listed above are required for proper assembly.
Extra hardware pieces may be included.*

Step 1

Using a screwdriver, secure Cam Bolts (B) into the designated holes on Top Panel (1)

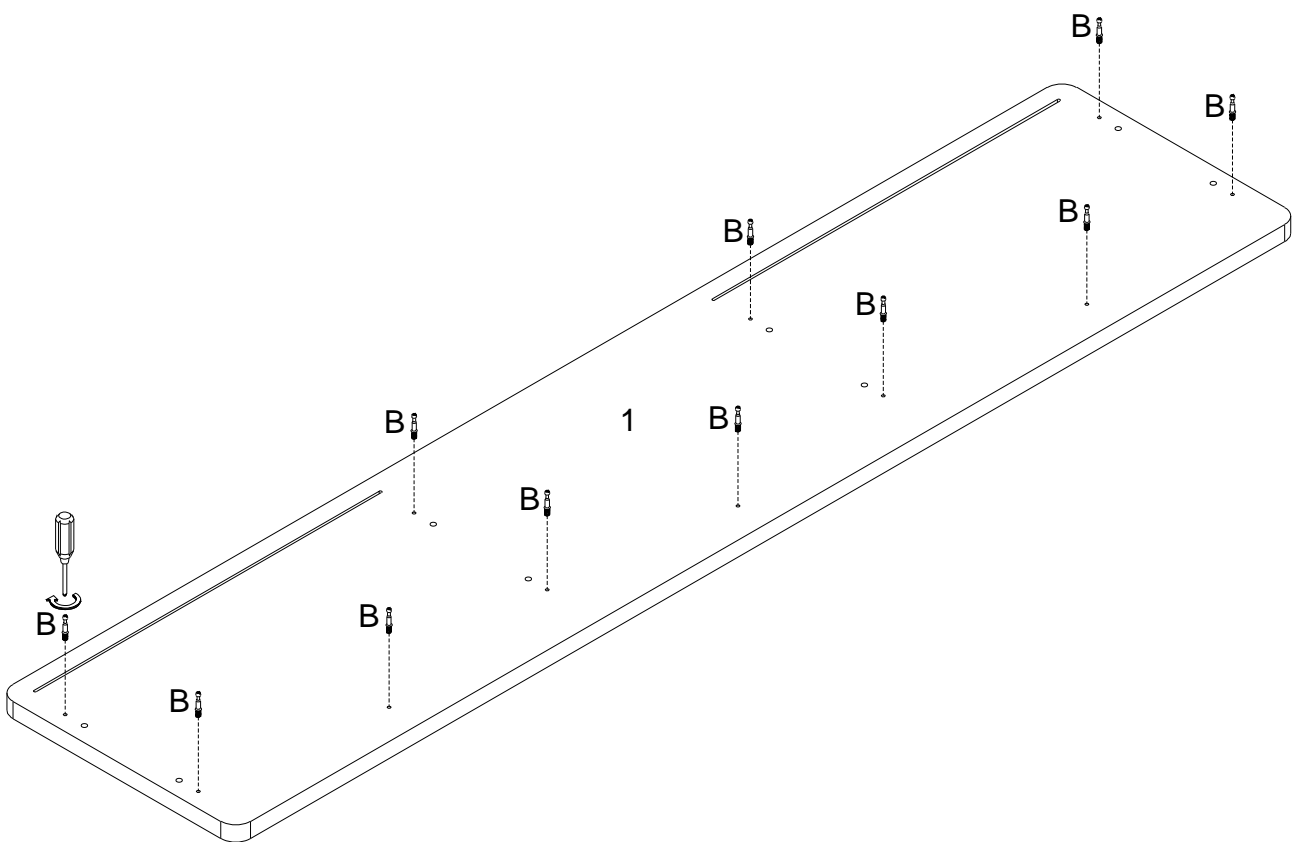

Step 2

Using a screwdriver, secure Cam Bolts (B) into the designated holes on Left Side Panel (3) and Right Side Panel (4). Insert Wooden Dowels (A) into the indicated holes, apply a small amount of Glue (N), and wipe away any excess.

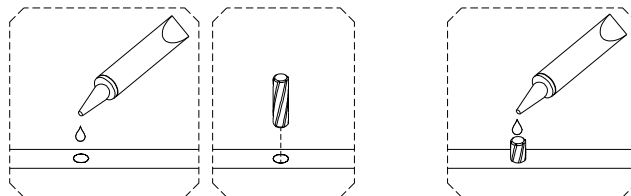
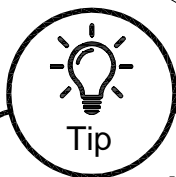
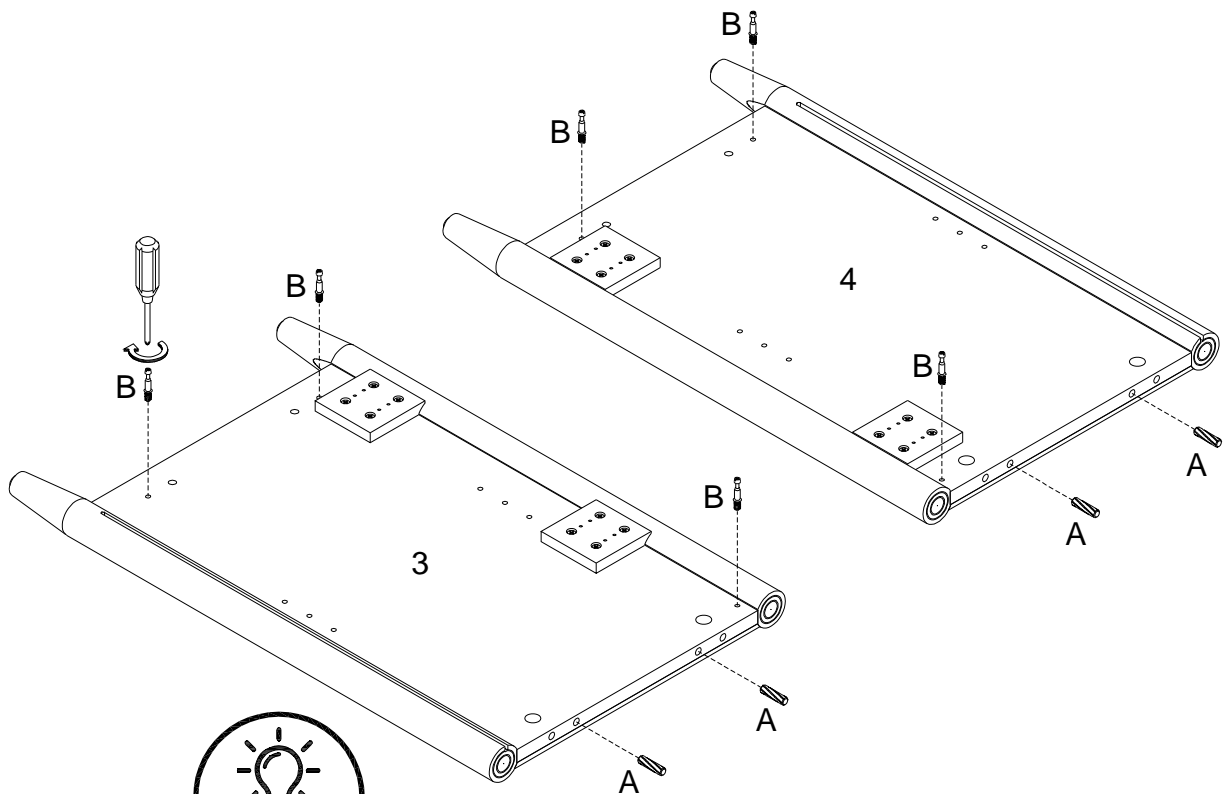

- 1: The provided glue is to secure wood dowels in place. When first inserting dowels, locate the appropriate hole for the dowel, place a small amount of glue in the hole and insert the dowel. Wipe away excess glue immediately.
- 2: In future assembly steps when dowels are necessary to attach assembly parts together, place a small amount of glue on the end of the dowel before attaching parts together. Wipe away excess glue immediately.

Step 3

Secure Cam Bolts (B) into Front Bottom Rail (12) using a screwdriver. Insert Wooden Dowels (A) into Bottom Panel (2) as shown.

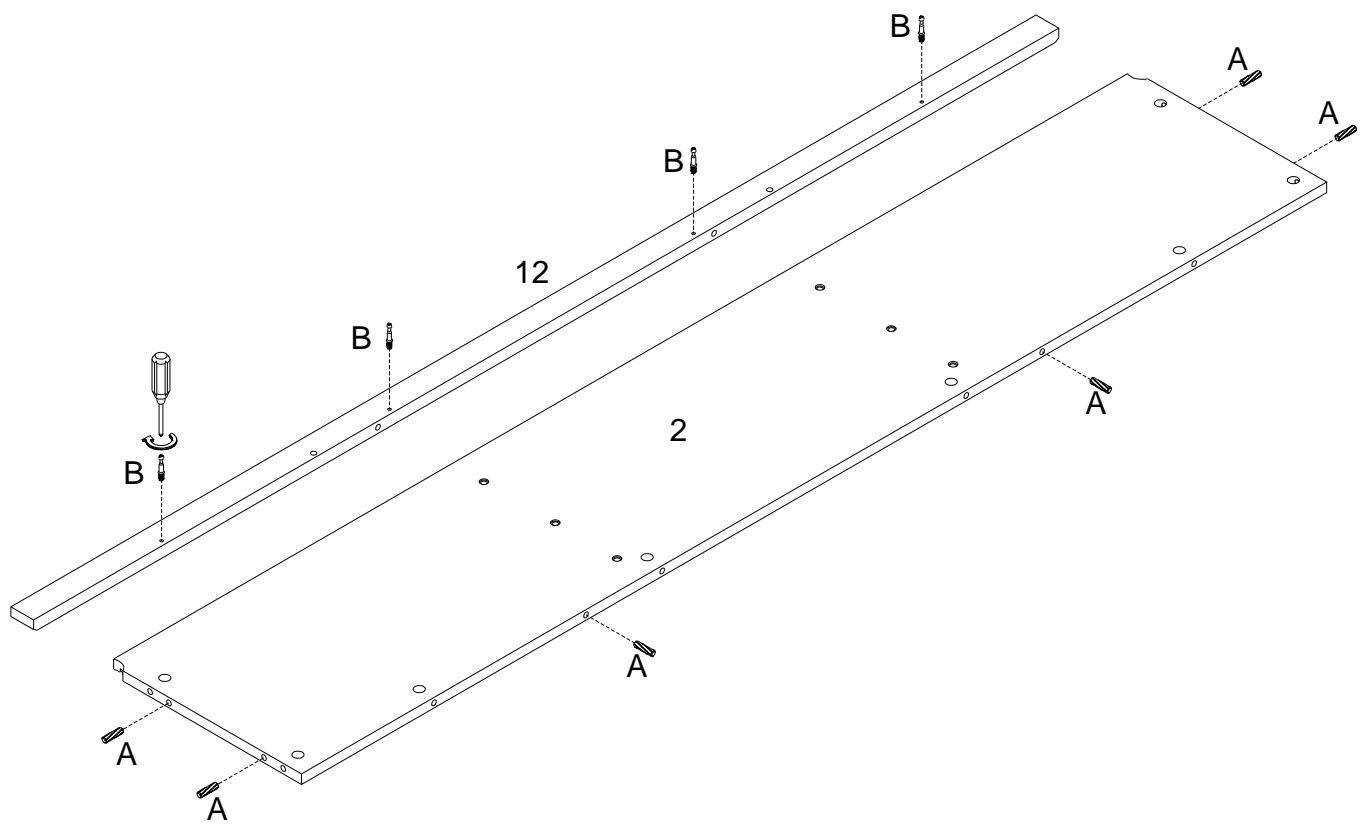

Step 4

Insert Wooden Dowels (A) into Center Divider Panel (10) as shown.

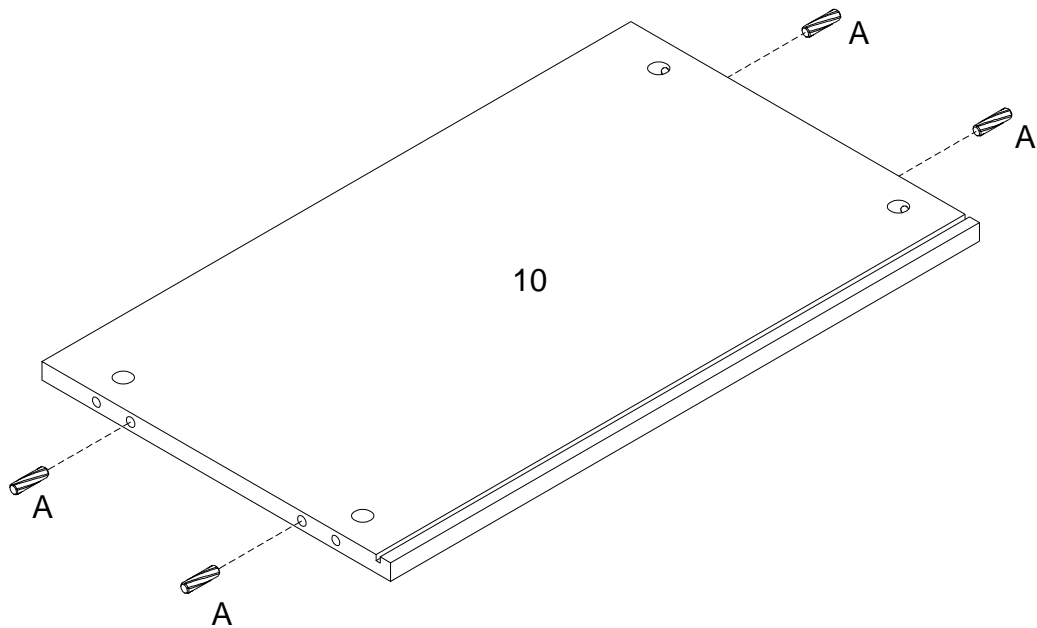

Step 5

Continue on to insert Wooden Dowels (A) into Left Divider Panel (5) and Right Divider Panel (6). Followed by securing cam bolts (B) with a screw driver into Left (5) and Right (6) Divider Panels.

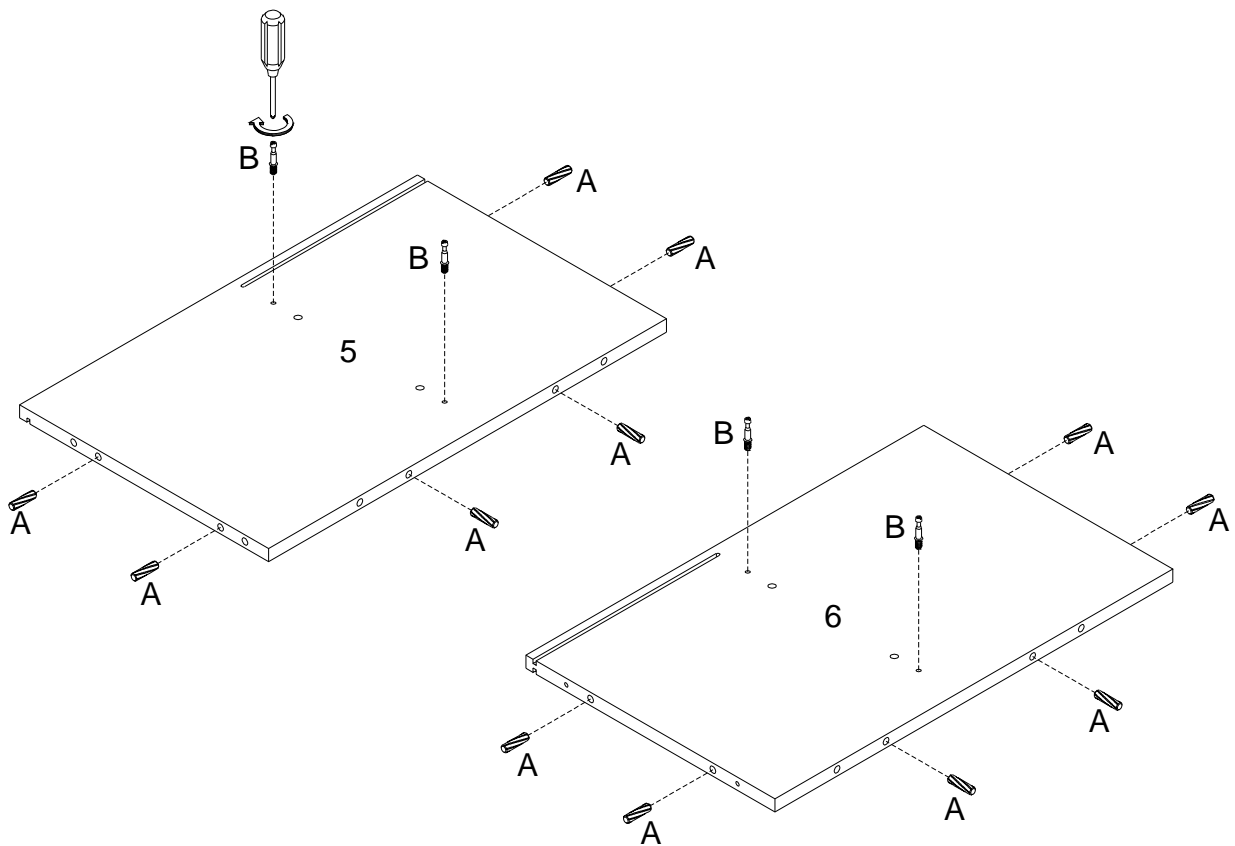

Step 6

Place Wooden Dowels (A) on each end of the Front Moldings (7). Followed by securing Cam Bolt (B) into indicated holes on Front Moldings (7)

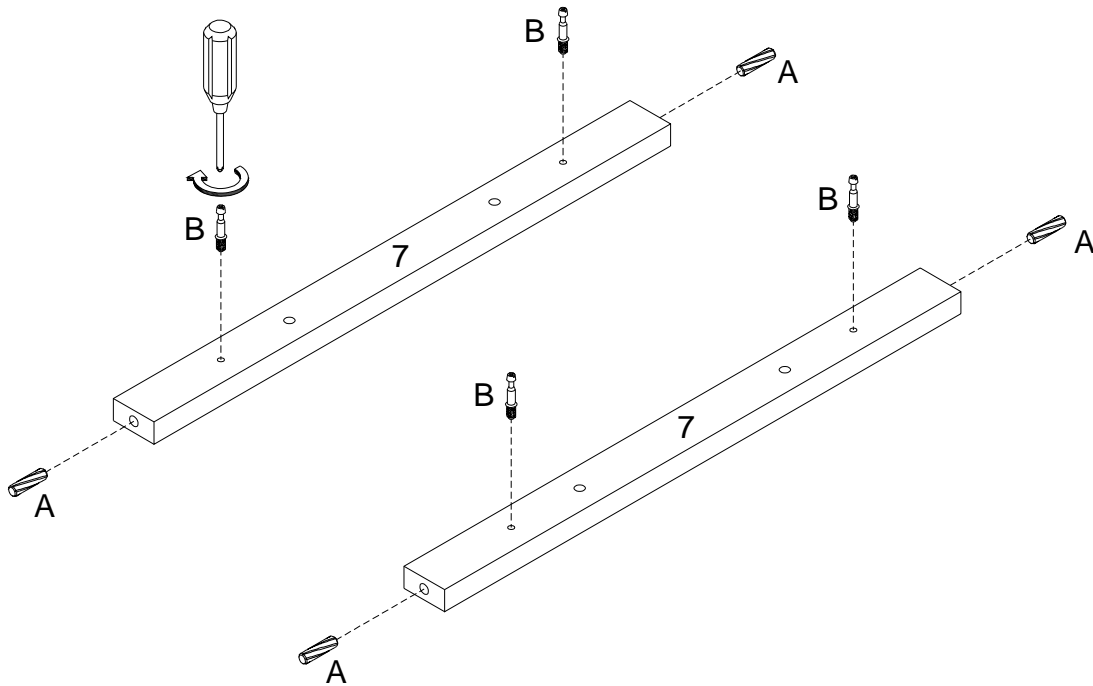

Step 7

Align Left Divider Panel (5) and Right Divider Panel (6) with Cam Bolts on Front Molding (7) and secure with Cam Locks (C)

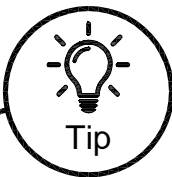
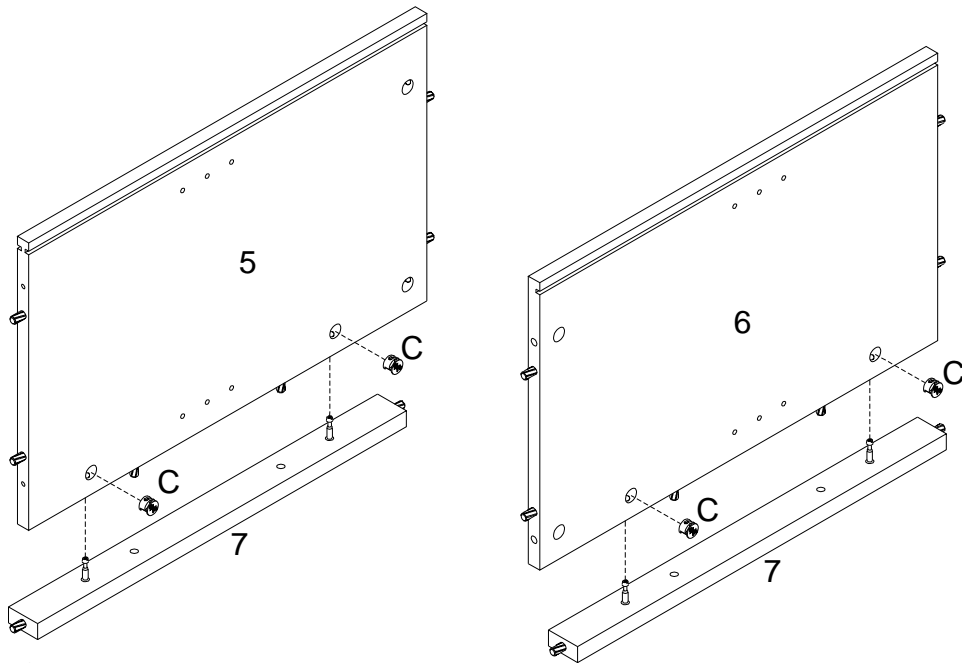

Cam Locks

Cam Locks help securely join two pieces together.
Follow these easy steps.

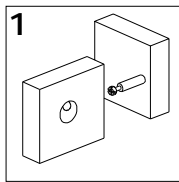

1: Insert Cam Bolt into bolt holes on the flat side. Don't over tighten!

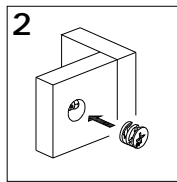

2: Fit the proper holes on the edge of the other part over the Cam Bolts. You should be able to see the cam bolts through the larger hole on the side.

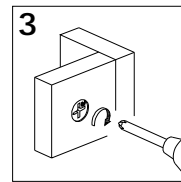

3: On the back of the Cam Lock will be a "C" shape. Insert the Cam Lock so the opening of the "C" fits over the Cam Bolt. Tighten with the screwdriver.

Step 8

Align Cam Bolts on Left Divider Panel (5) and Right Divider Panel (6) with holes in Fixed Divider Panel (10). Insert Cam Locks (C) into Fixed Divider Panel (10) and tighten with a screwdriver.

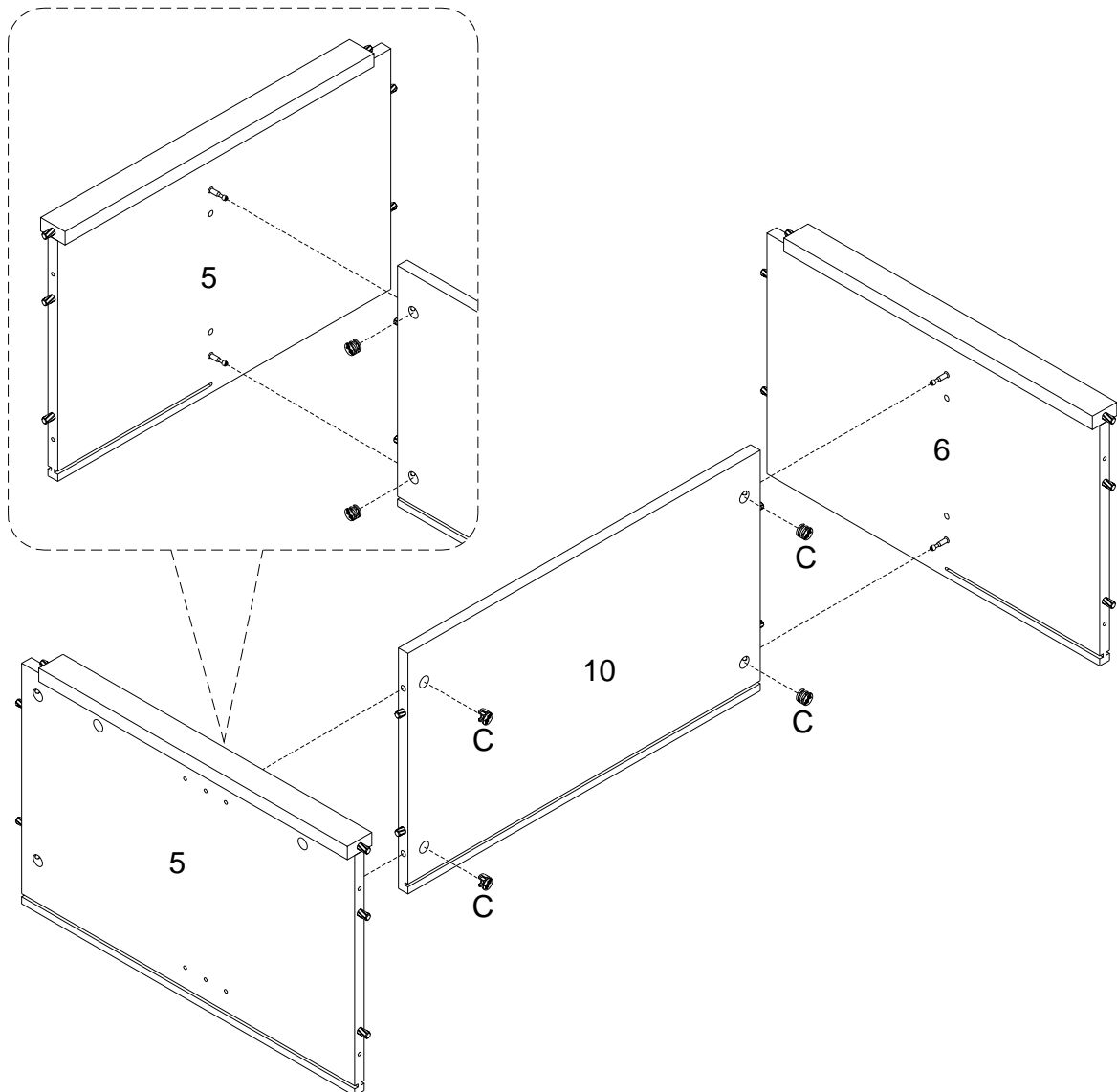

Step 9

Slide Middle Back Panel (14) into the grooves of Divider Panels (5) and (6).

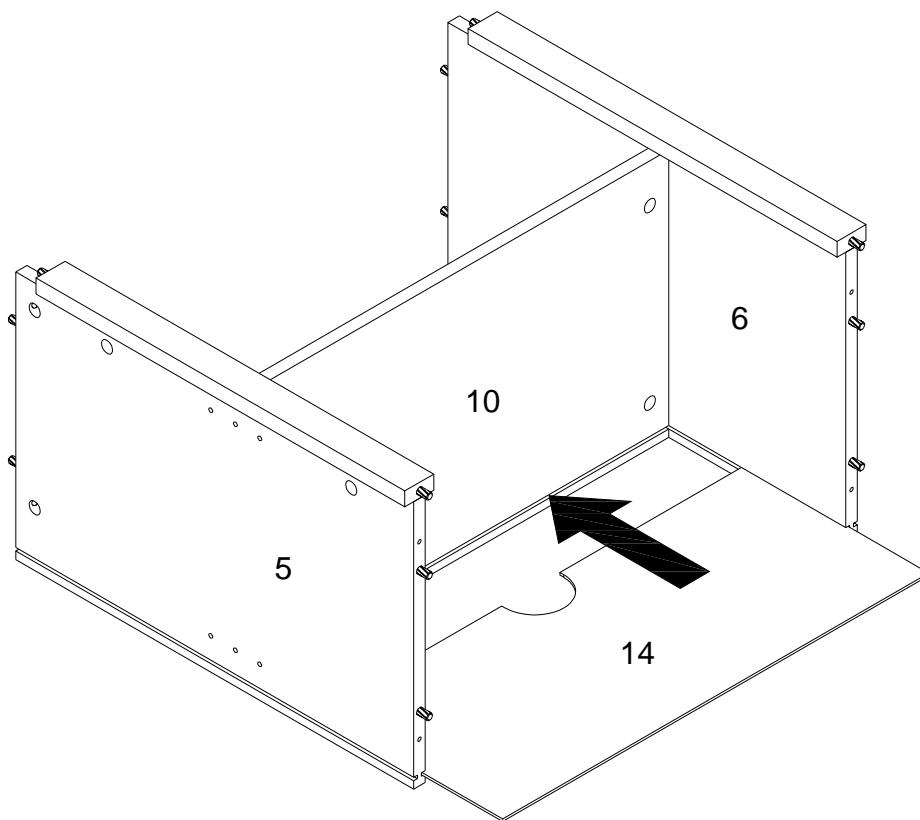

Step 10

Align Cam Bolts on Front Bottom Rail (12) with Bottom Panel (2). Insert Cam Locks (C) and tighten them.

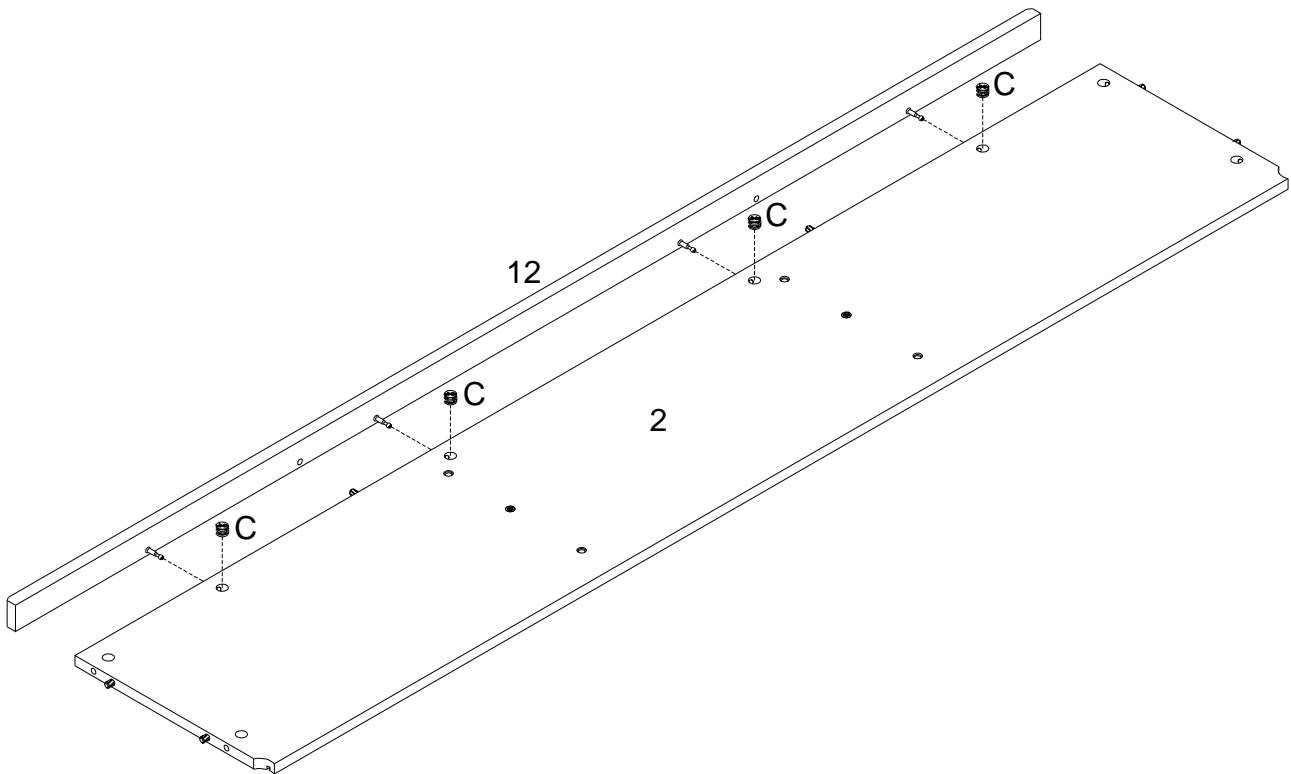

Step 11

Attach Middle Feet (16) to Bottom Panel (2) by aligning them with the designated holes and twisting to secure.

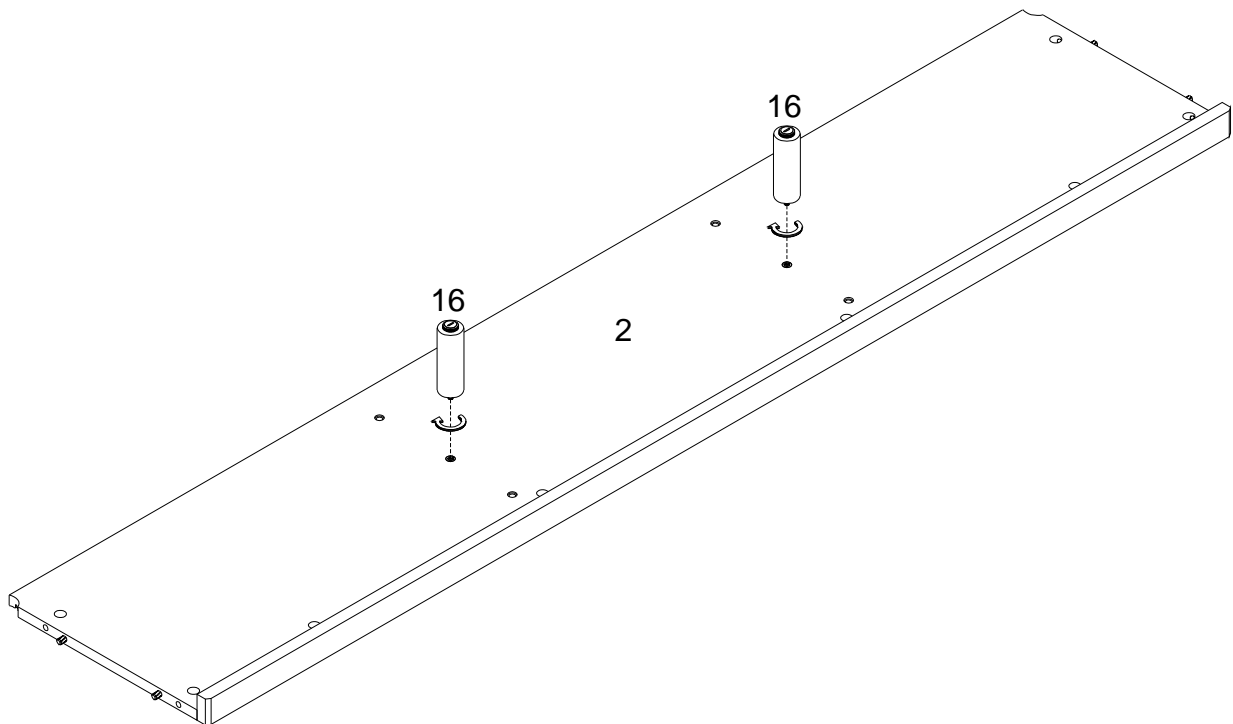

Step 12

Align Divider Panels (5) and (6) with the designated holes on Bottom Panel (2). Insert Bolts (E) and tighten using Hex Key (F).

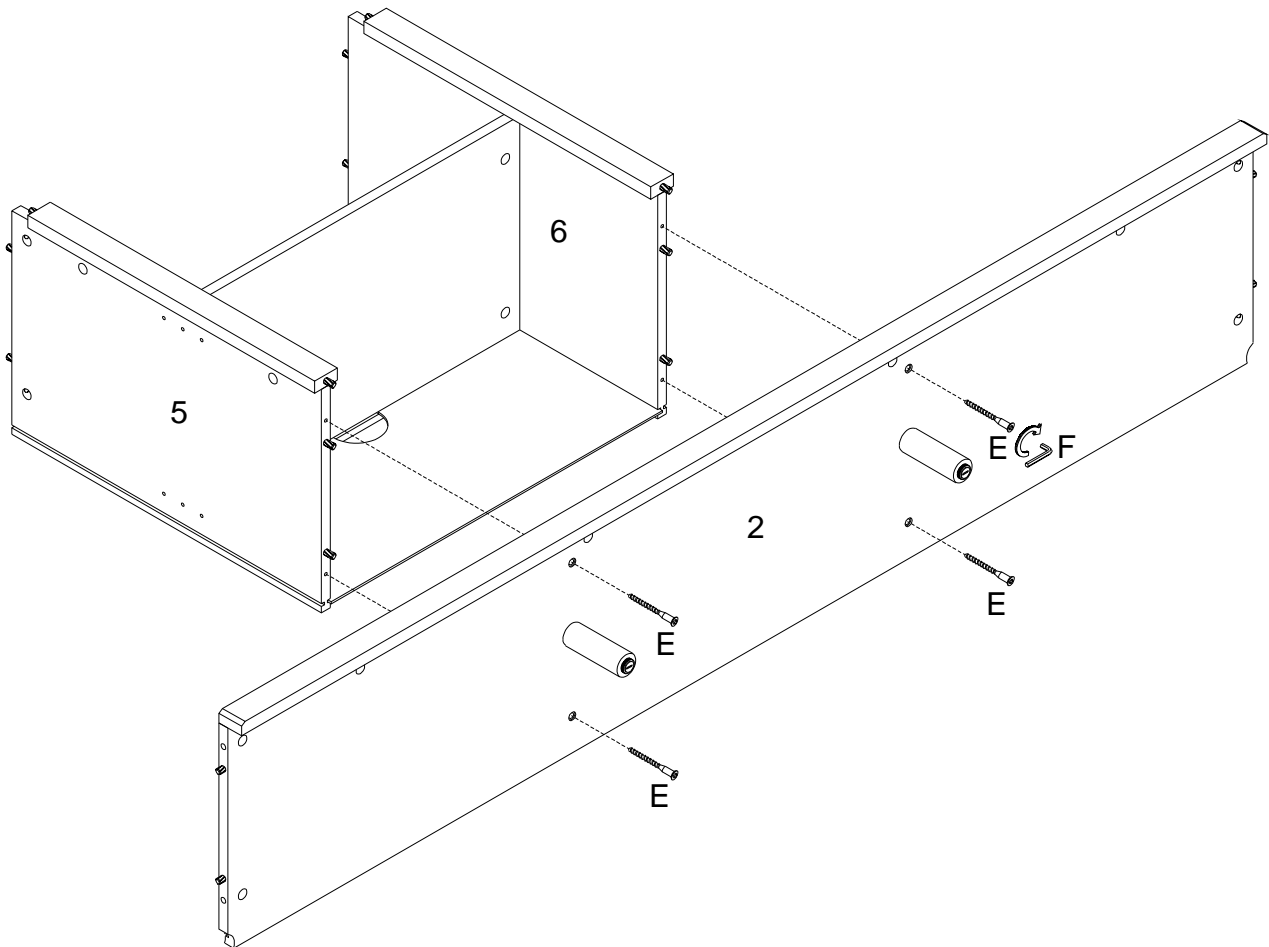

Step 13

Align the wooden dowels on Front Upper Rail (11) with the designated holes on Divider Panels (5) and (6).

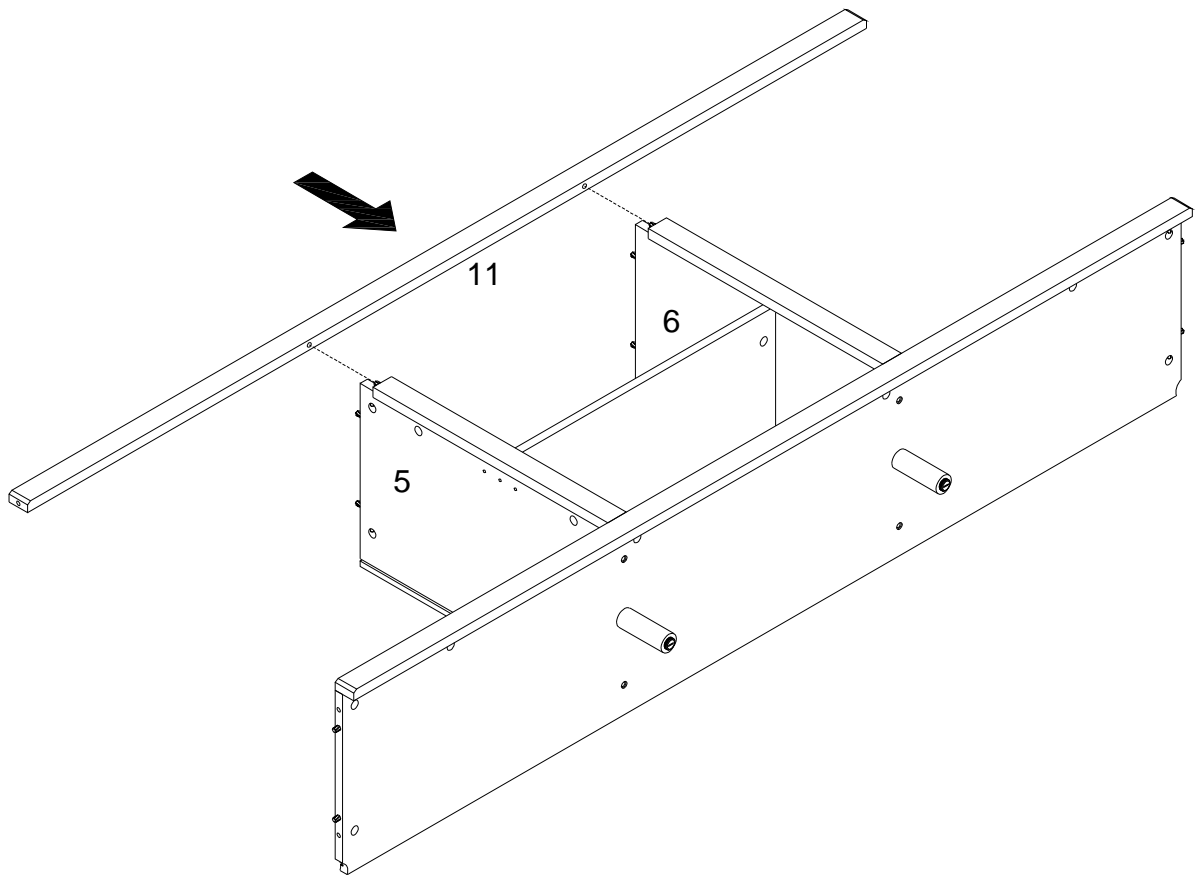

Step 14

Align Cam Bolts on Left Side Panel (3) with the designated holes on Front Upper Rail (11) and Bottom Panel (2). Secure using Cam Locks (C).

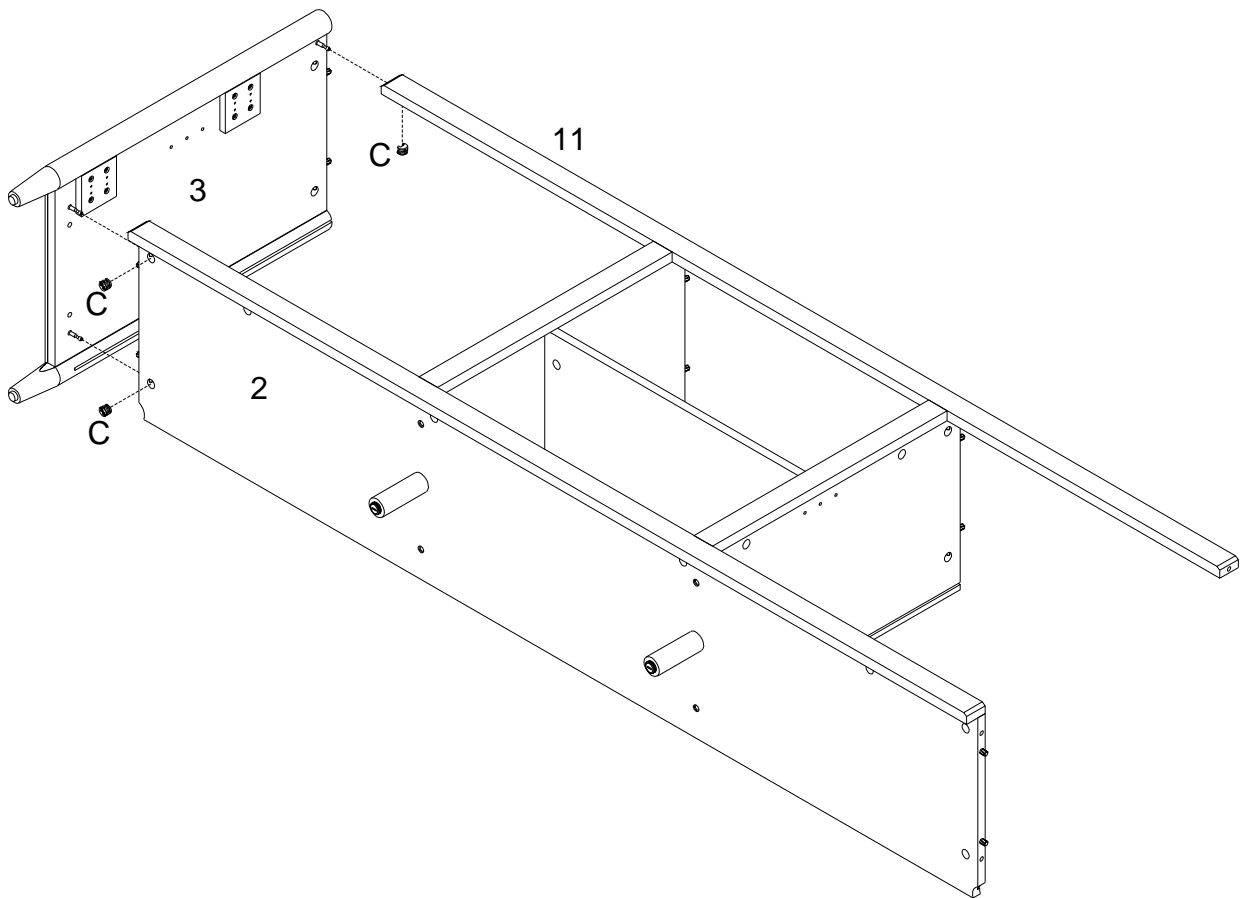

Step 15

Align Cam Bolts on Right Side Panel (4) with the designated holes on Front Upper Rail (11) and Bottom Panel (2). Secure using Cam Locks (C).

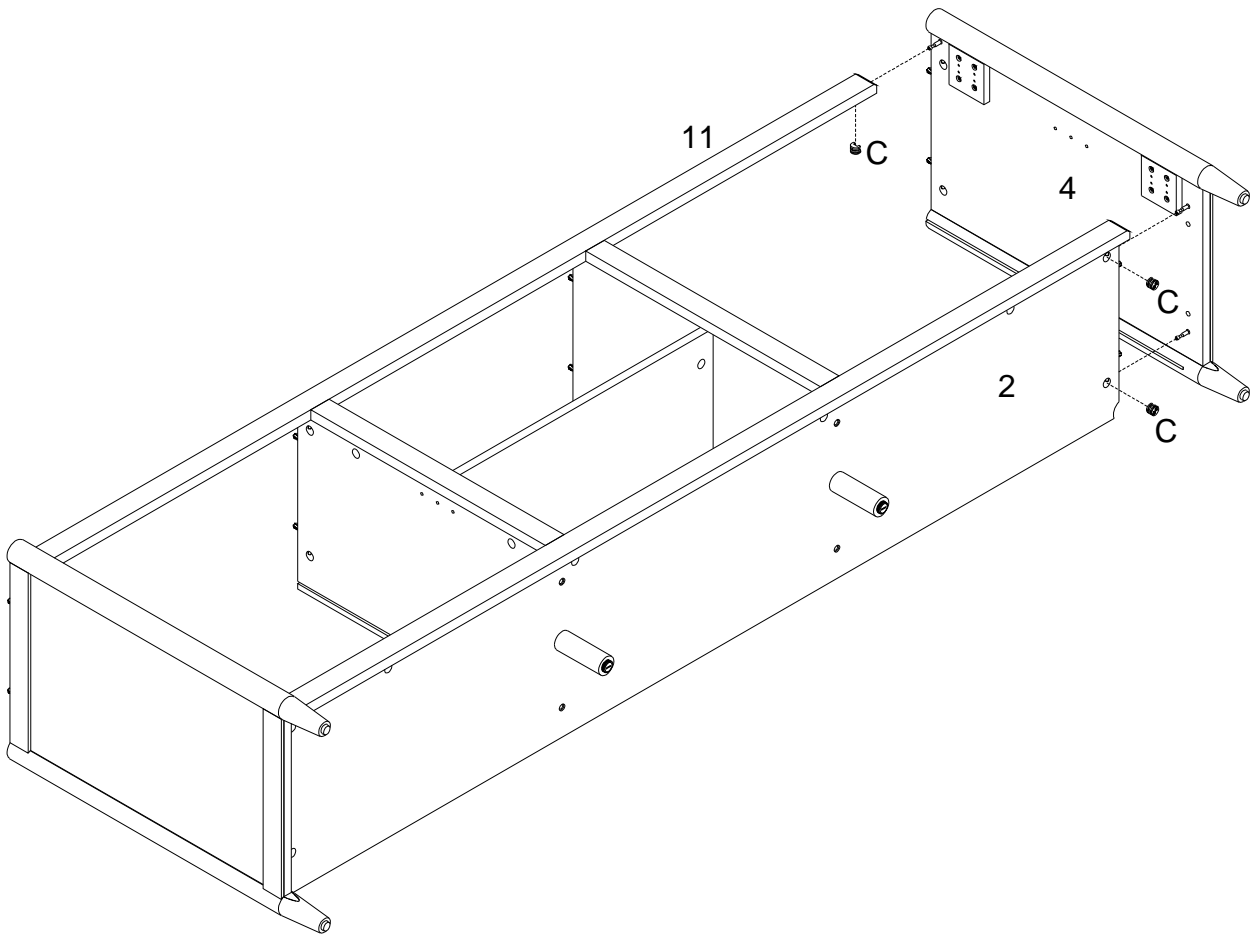

Step 16

Insert Left/Right Back Panels (13) into the grooves between the Divider Panels and Side Panels.

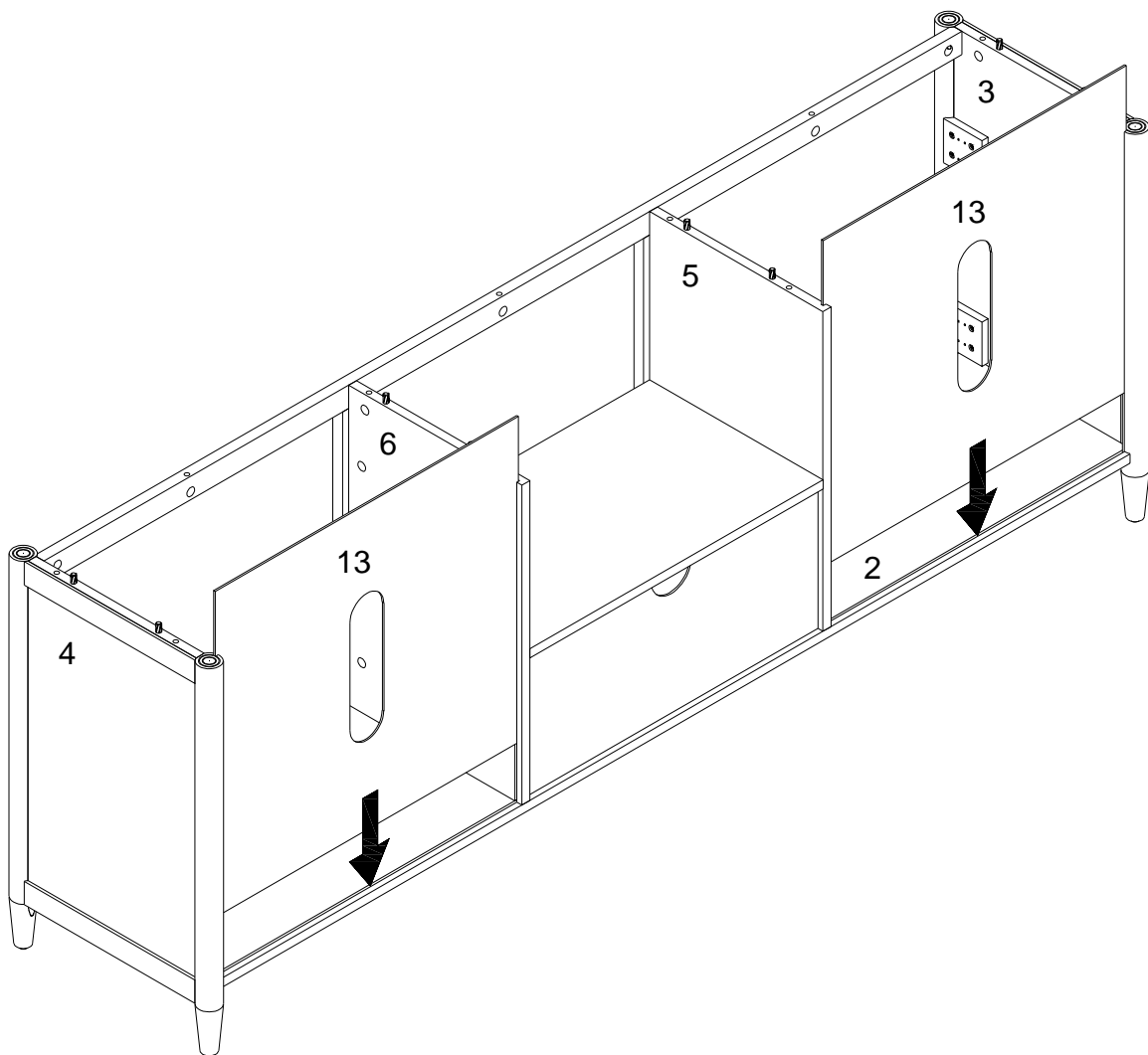

Step 17

Align the Cam Bolts on the underside of Top Panel (1) with the corresponding holes on the assembled piece. Secure each bolt using Cam Locks (C) from underneath.

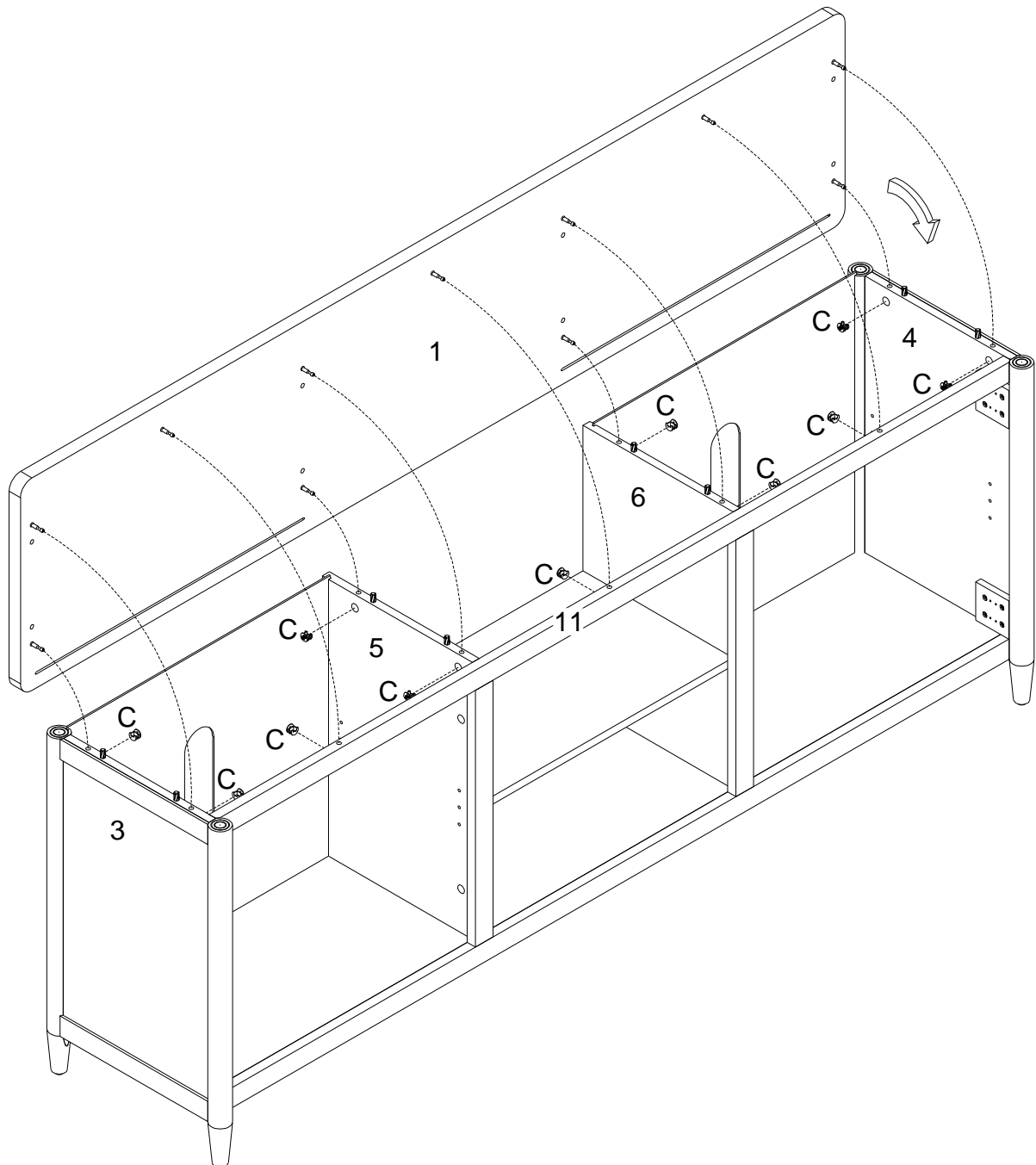

Step 18

Secure Back Panels with Plastic Wedges (K), spacing them evenly, and fasten each with Screws (L).

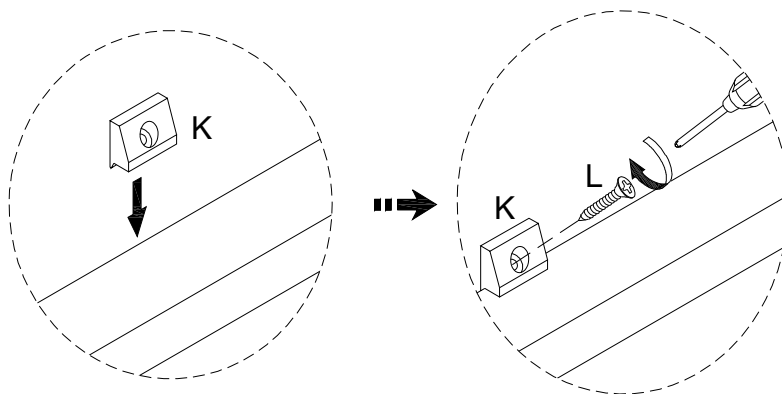
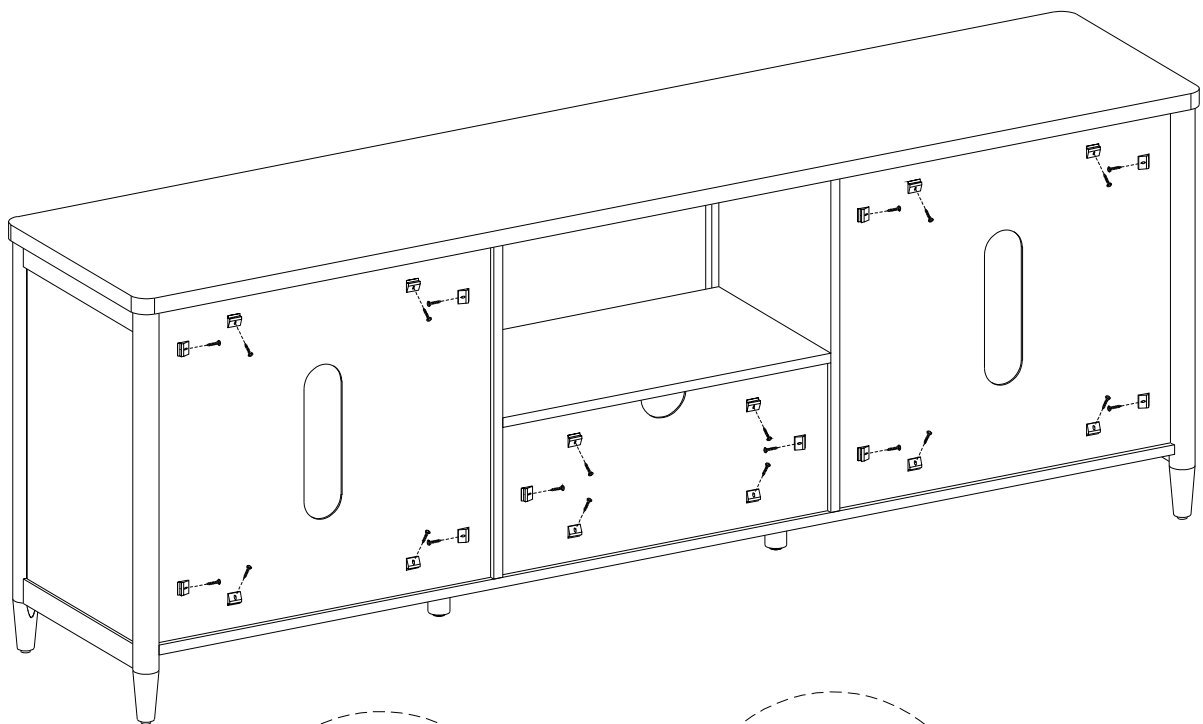

Step 19

Place Stickers (D) over exposed Cam Lock holes on interior of tv stand.

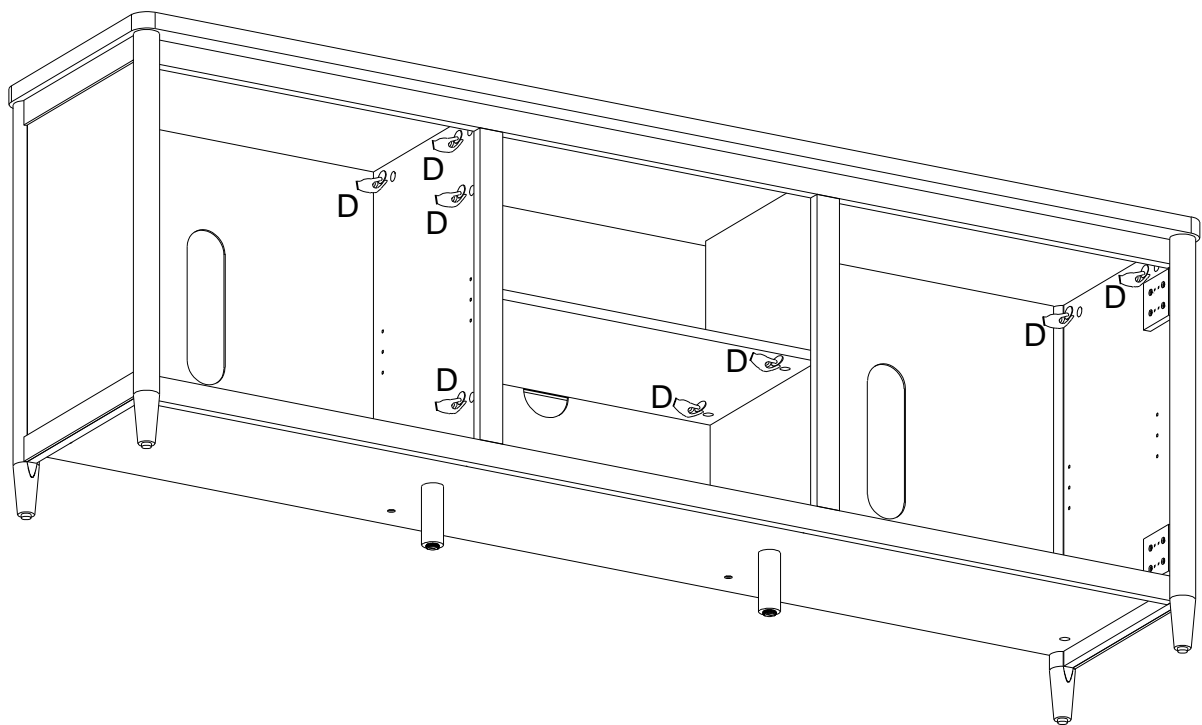

Step 20

Decide the desired height for your shelves, then insert Shelf Support Pins (J) into the pre-drilled holes, ensuring they are level on both sides. Place Adjustable Shelves (8) and (9) on top of the pins.

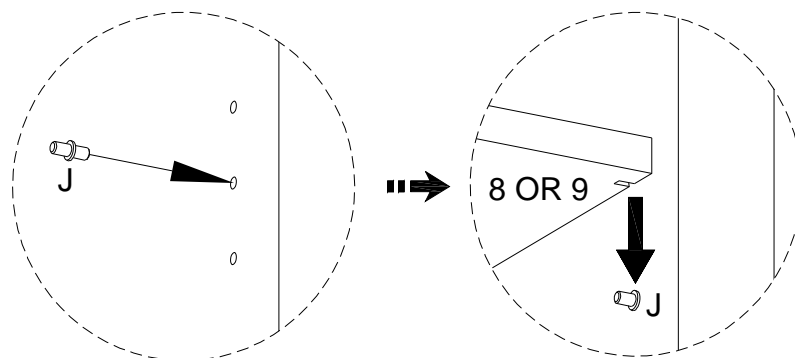
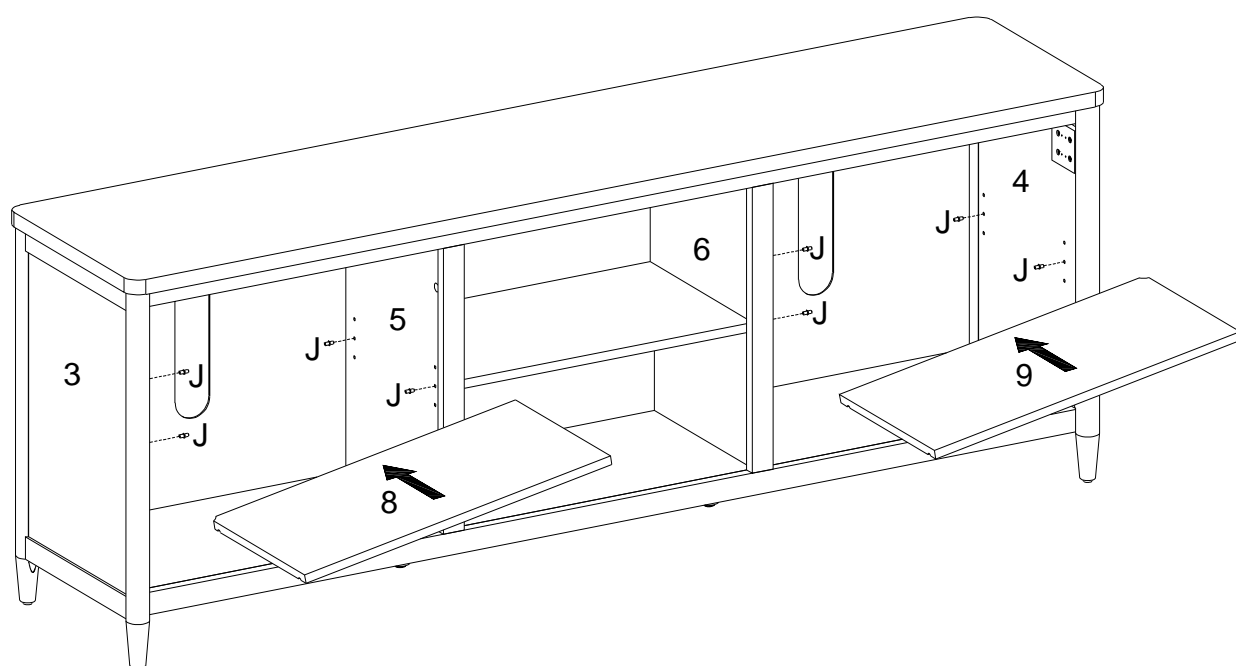

Step 21

Connect Hinges (G) to the two Door Panels (15) and tighten them with Screws (H). Stick Rubber Pads (M) into place.

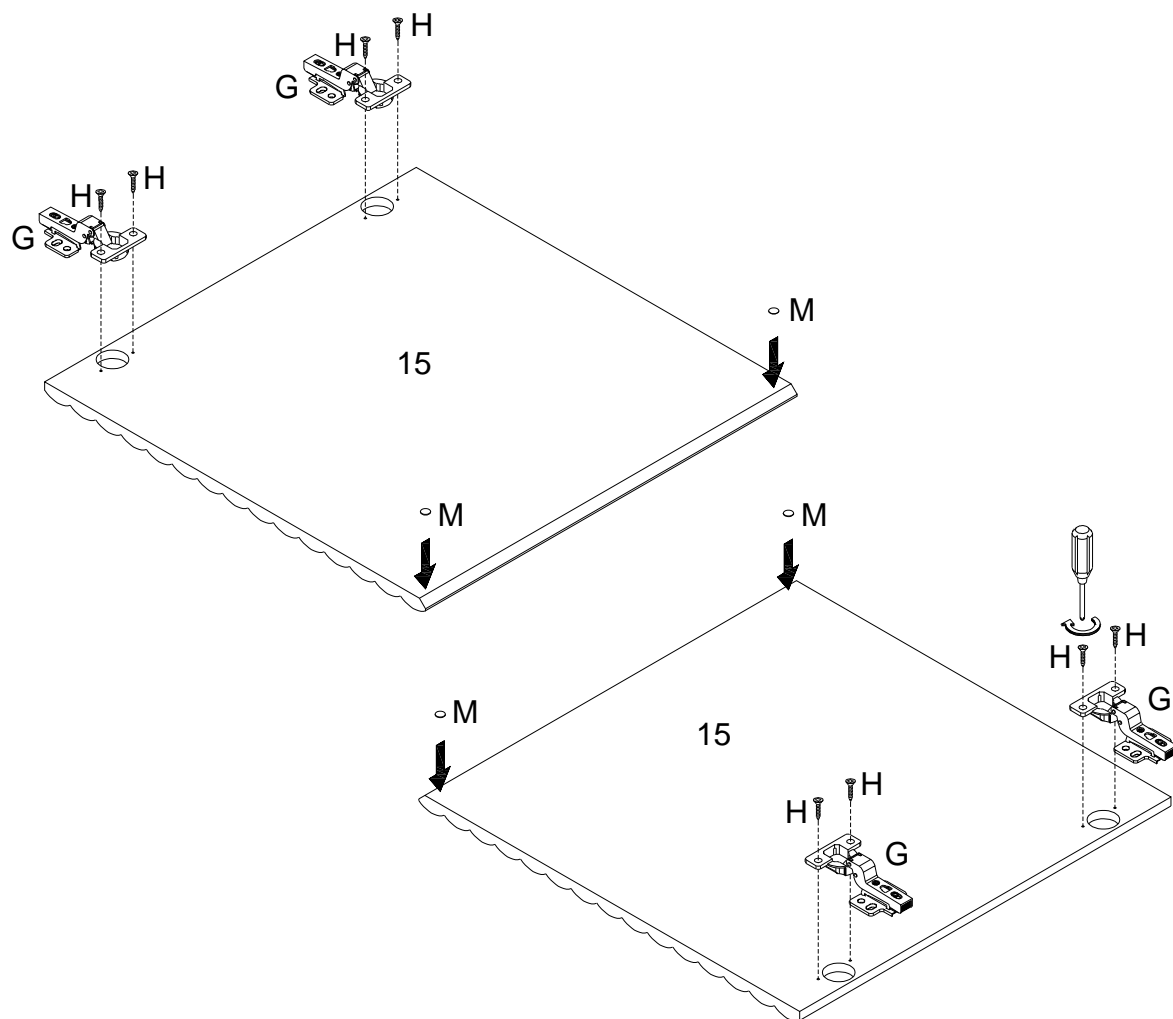

Step 22

Align Hinge (G) on Door Panel (15) to Side Panel (3) and tighten them with screws (H). Adjust as needed with a screw driver.

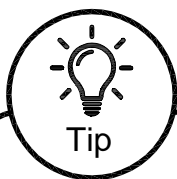
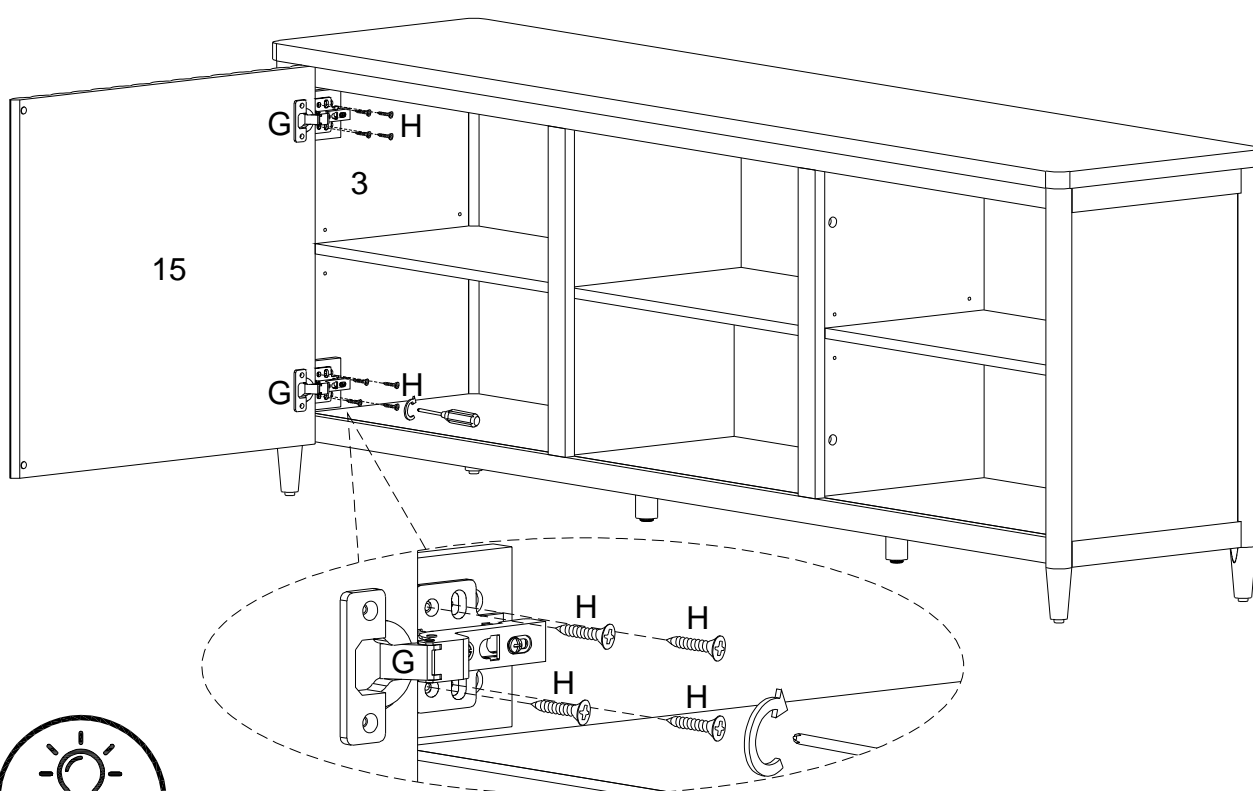

Adjusting The Cabinet Doors

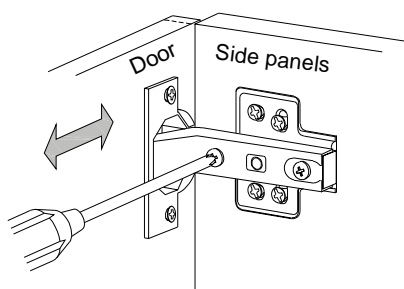

Adjust horizontal width with this screw.

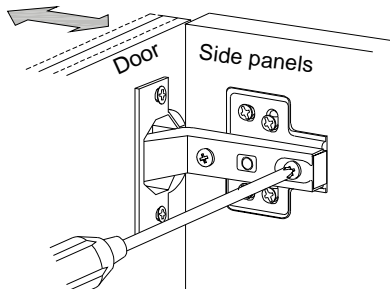

Adjust depth position by loosening the hinge arm mounting screw.

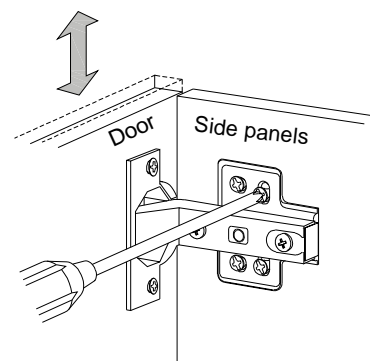

Adjust vertical height via the screws in the mounting plate.

Step 23

Repeat hinge alignment to Right Side Panel (4) and adjust as needed.

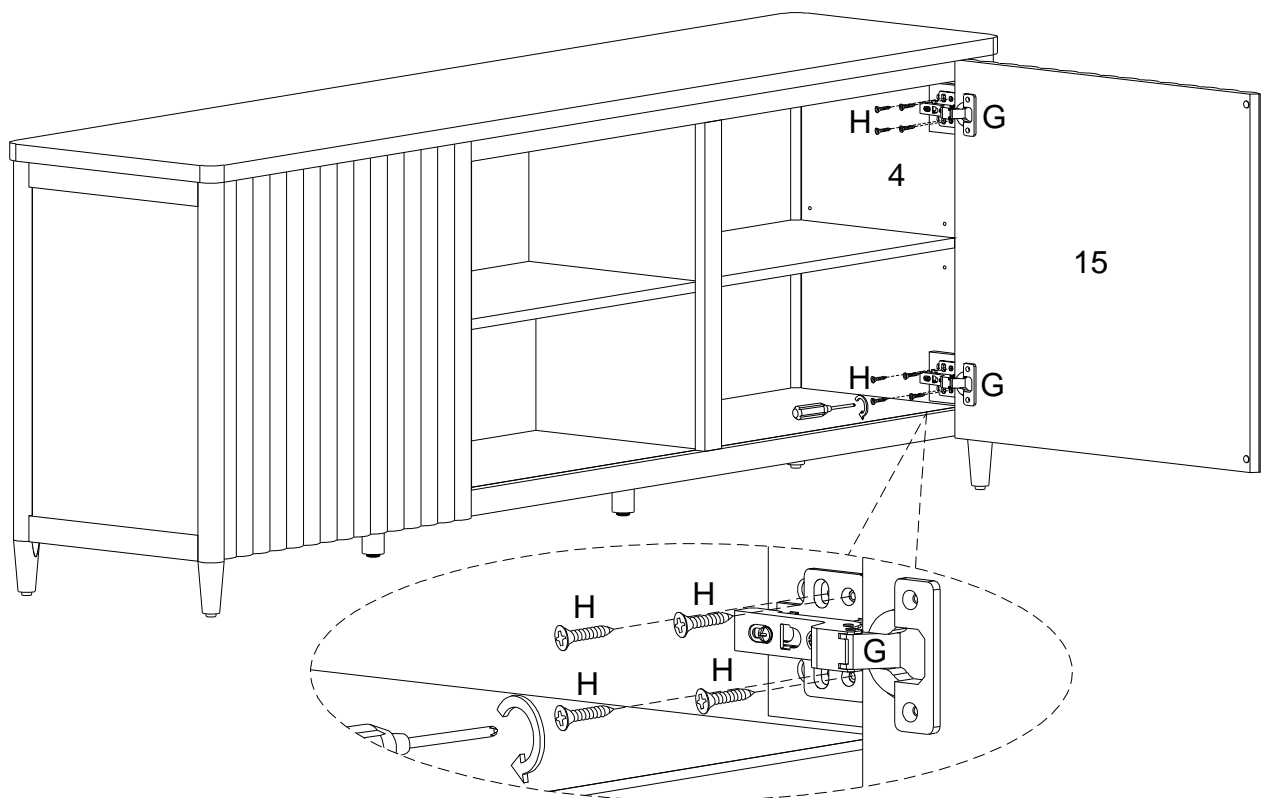

Step 24

Adjust the levelers as shown until the surface of your TV stand is completely flat and stable.

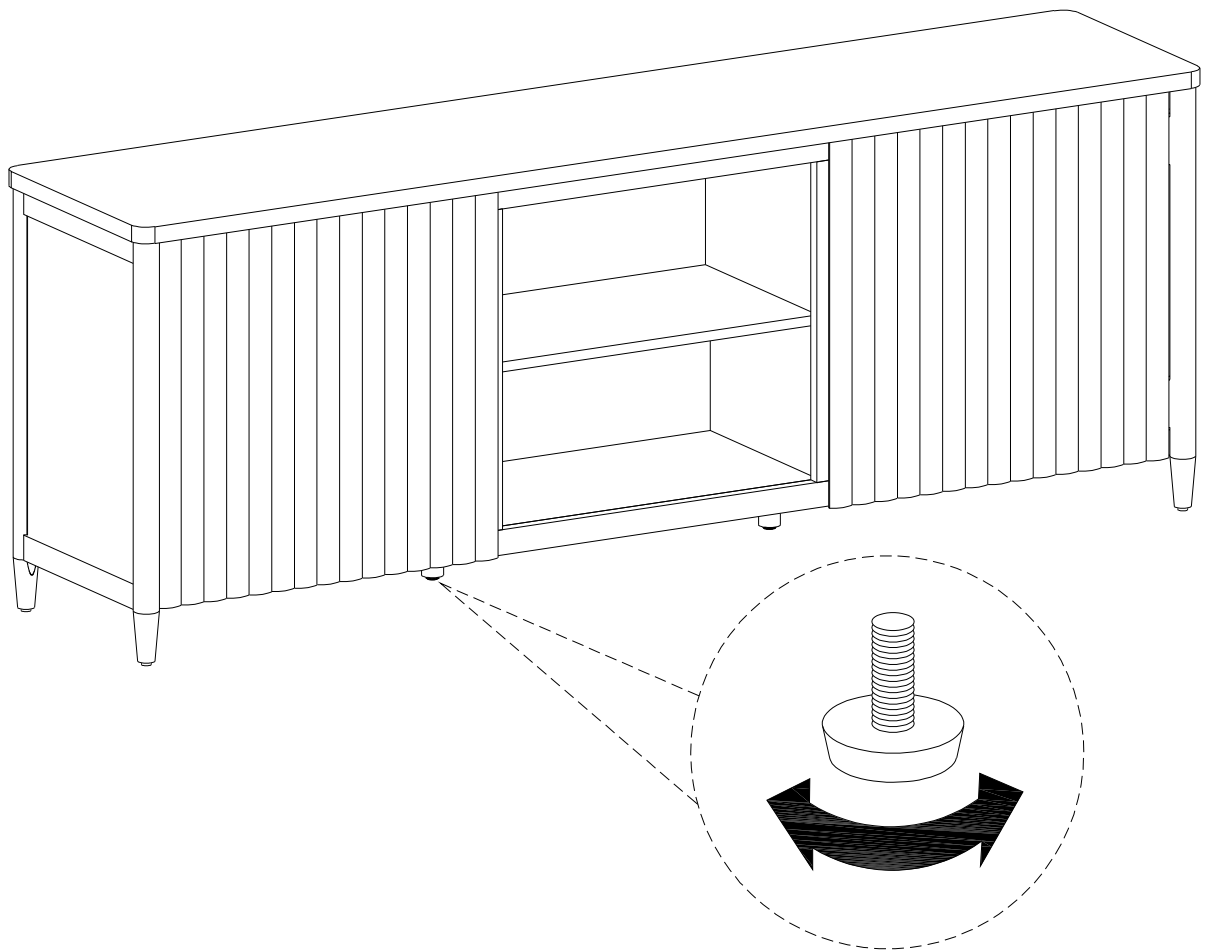

Final Assembly

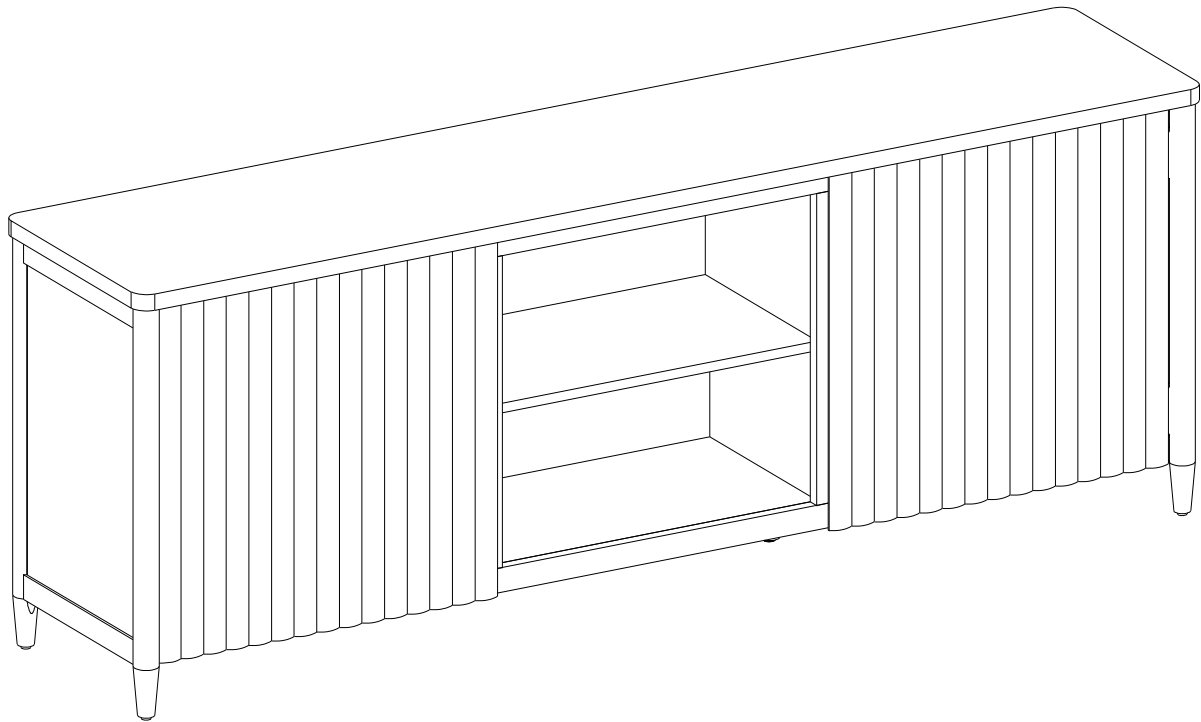

Congratulations on your new piece of furniture!

We would love to hear about it and see it.
Please leave us a review or post a picture with
[#mywalkerredisonhome](#)

Assembling furniture can be tricky sometimes.

Our customer service team, located in Utah, is here for product information, help assembling a product, or for any other customer support issue

Call us at **801-433-3008**

Email us at service@walkeredison.com

Visit our Customer Service website at
walkeredison.com/pages/customer-service

We are available to help Monday -Thursday 8am-5pm, Friday
8am-3pm MST

For details on Assembly Videos, Assembly Instructions,
Replacement Parts, and Customer service,
SCAN HERE

