











HEKMAN[®]

A HOWARD MILLER COMPANY

ASSEMBLY INSTRUCTIONS FOR 25364 QUEEN UPHOLSTERED BED

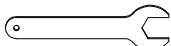
HARDWARE LIST

NO.	ITEM	DESCRIPTION	QTY	NO.	ITEM	DESCRIPTION	QTY
1		BOLT Ø1/4" x 1-1/4"	2	2		LOCK WASHER	18
3		FLAT WASHER	18	4		ALLEN WRENCH	1
5		BOLT Ø1/4" x 1/2"	8	6		THREADED ROD Ø5/16" x 4"	8
7		HEXAGONAL NUT Ø5/16"	8	8		HALF MOON NUT	8
9		WRENCH	1	10		BOLT Ø1/4" x 3/4"	8
11		WOOD SCREW 1"	8				

STEP 2

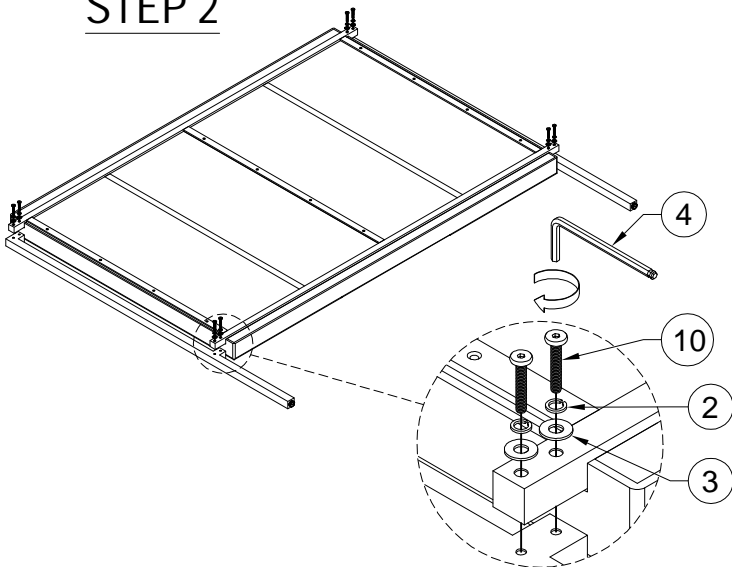

STEP 3

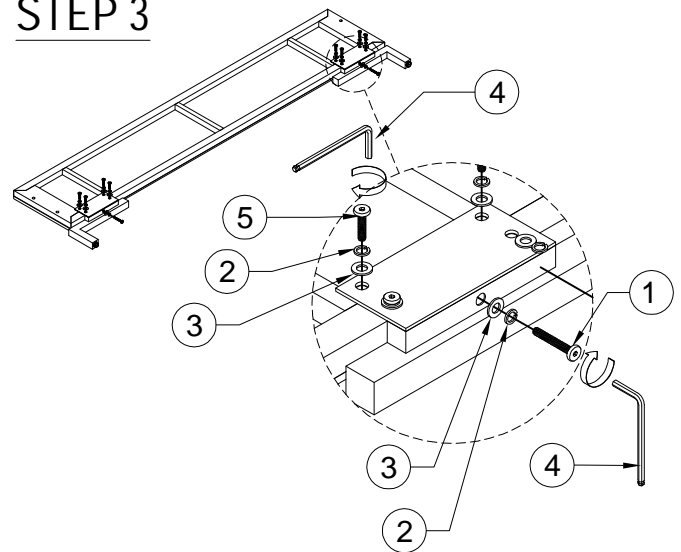

STEP 4

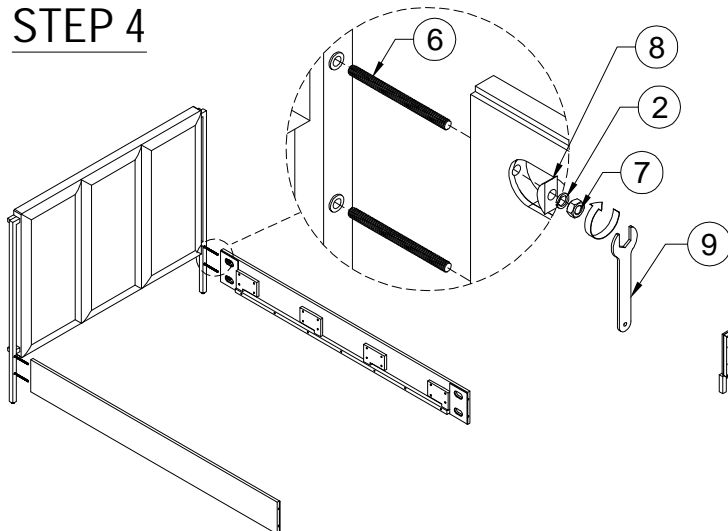

STEP 5

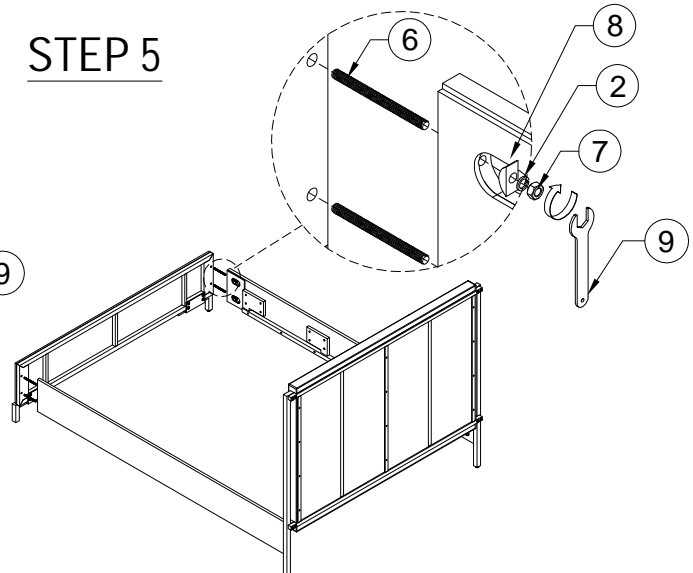

HEKMAN[®]

A HOWARD MILLER COMPANY

ASSEMBLY INSTRUCTIONS FOR 25364 QUEEN UPHOLSTERED BED

HARDWARE LIST

STEP 6

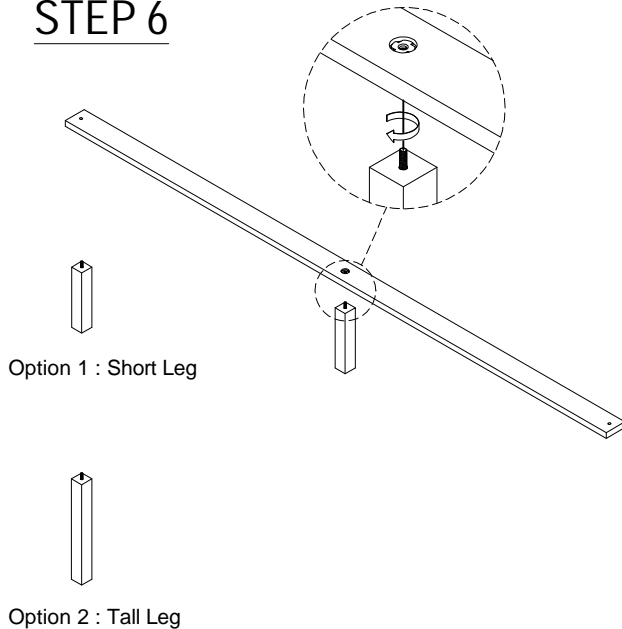

STEP 7

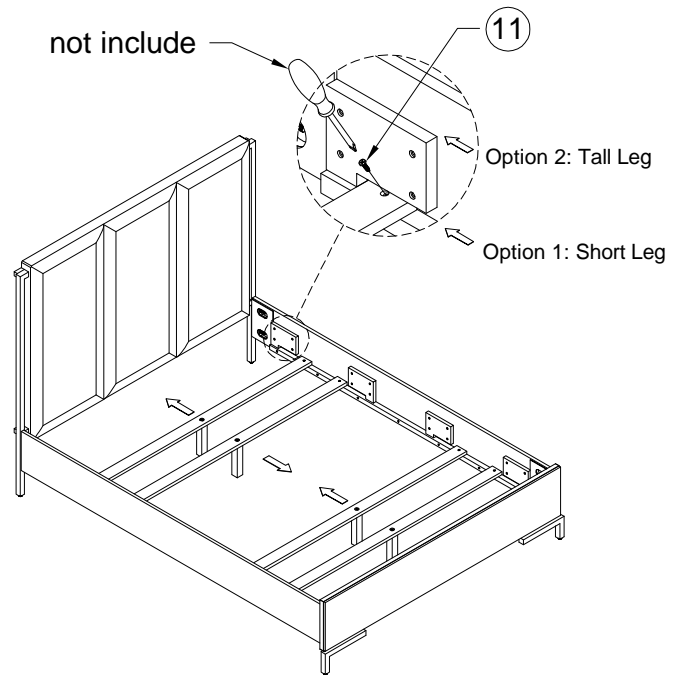

TO ASSEMBLY:

STEP 1: Lay the headboard & the footboard face down on a piece of cloth or carpet to prevent the finish from scratching.

STEP 2: Attach the legs to the headboard. Insert the flat washer (3), lock washer (2), with medium bolt (10) to the headboard, tighten with allen wrench (4).

STEP 3: Attach the legs to the footboard. Insert the flat washer (3), lock washer (2), with long bolt (1) & short bolt (5) to the footboard, tighten with allen wrench (4).

STEP 4 & 5: Insert the threaded rod (6) into the headboard and the footboard, tighten all threaded rod at this time. Then assemble the side rail to the headboard and the footboard using halfmoon (8), lock washer (2), and hex nut (7) as picture shown, tighten with wrench (9).

STEP 6: Assemble the middle leg to the slat. Tighten at this time. 2 option for middle leg height.

STEP 7: Attach the slats with middle leg into the groove on the side rail with wood screw (11).

STEP 8: Assembly of the product is now completed.

