

# Product Specifications

## 5.0-Gallon Round Container with Lo-Vis EZ Cover®

### Multiple Uses

Dry Products  
Liquid Products

### Product Codes

Container: **R059**  
Description: 5.0-gallon round can

### Cover: **LTGZ**

Description: Tamper-evident, Lo-Vis EZ Cover® with four tabs and tubular gasket

### Features

Gauge: 90 mil.  
Nominal capacity: 5.0 USG / 19.0 L  
Stack performance: 400 lbs.\*  
Tare weights: Body: 2.08 lbs. / .94 kgs.  
Cover: .58 lbs. / .26 kgs.

Note: \*Ratings will be reduced with uneven load distribution.

### Specifications with Cover

Dimensions: 12-3/8"D. X 14-11/16"H  
Maximum capacity: 5.6 USG / 21.2 L  
Tare weight: 2.66 lbs. / 1.20 kgs.

### Colors

Standard: White, Black and Natural  
Custom: Available at manufacturer's discretion

### Decorating Options

Silk-Screening: 32"W X 8-3/4"H  
Four or six\* color offset printing  
Print area: 34"W X 9-1/4"H  
Sleeve or pressure sensitive labeling

Note: \*Where available

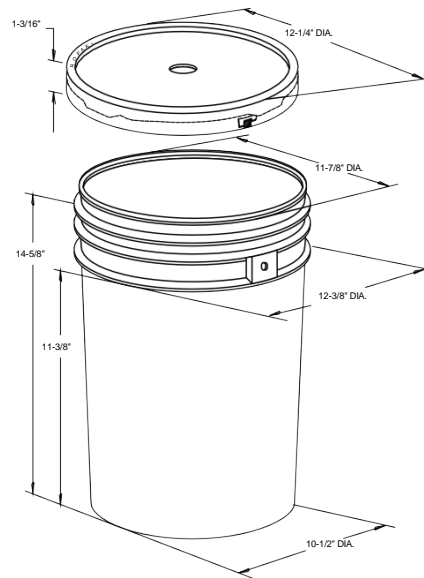

### Shipping Data

	<b>Bodies</b>	<b>Covers</b>
Qty. per pallet/carton:	144	1,152 (24 boxes of 48)*
Gross Weight (lbs./kgs.)**:	299.5/135.4	668.2/299.5
Den. (lbs./C.F./kgs./m3):	5.7/90.3	5.5/86.6
Length (in./cm.):	49.3/125.2	52/132.1
Width (in./cm.):	37.5/95.3	40/101.6
Height (in./cm.):	49.5/125.7	101.5/257.8

Estimated truckload quantity of 6,336 bodies and covers\*\*\*

### Filled Containers

36 (12 per layer / 3 layers high)  
Pallet height: 48.8"

Notes: \*Bulk pack also available  
\*\*Weight does not include pallet/packaging  
\*\*\*Truckload quantity based on 53' trailer

### Materials

FDA approved materials  
Resin: Body: High-Density Polyethylene (HDPE)  
Cover: High-Density Polyethylene (HDPE)  
Ethylene Propylene Diene Monomer (EPDM) Gasket

MSDS Sheets available upon request

### Optional Carrying Handle

**DISCLAIMER**  
THIS INFORMATION IS PROVIDED AS A GENERAL GUIDE, INCLUDING DIMENSIONS. IT IS THE CUSTOMER'S RESPONSIBILITIES TO SELECT THE PROPER CONTAINER FOR PRODUCT AND APPLICATION COMPATIBILITY.

DISTRIBUTED BY:



REF NO.:

DWG30570

DESCRIPTION:

HDPE EZ Stor Cover for 5 Gallon Pails