

# 5.0-Gallon Round Container

## Multiple Uses

Dry Products  
Liquid Products

## Product Codes

Container: **R059**  
Description: 5.0-gallon round can

## Features

Gauge: 90 mil.  
Nominal capacity: 5.0 USG / 19.0 L  
Stack performance: 400 lbs.\*  
Tare weights: Body: 2.08 lbs. / .94 kgs.

Note: \*Ratings will be reduced with uneven load distribution.

## Specifications with Cover

Dimensions: 12-3/8"D. X 14-11/16"H  
Maximum capacity: 5.6 USG / 21.2 L  
Tare weight: 2.66 lbs. / 1.20 kgs.

## Colors

Standard: White, Black and Natural  
Custom: Available at manufacturer's discretion

## Decorating Options

Silk-Screening: 32"W X 8-3/4"H  
Four or six\* color offset printing  
Print area: 34"W X 9-1/4"H  
Sleeve or pressure sensitive labeling

Note: \*Where available

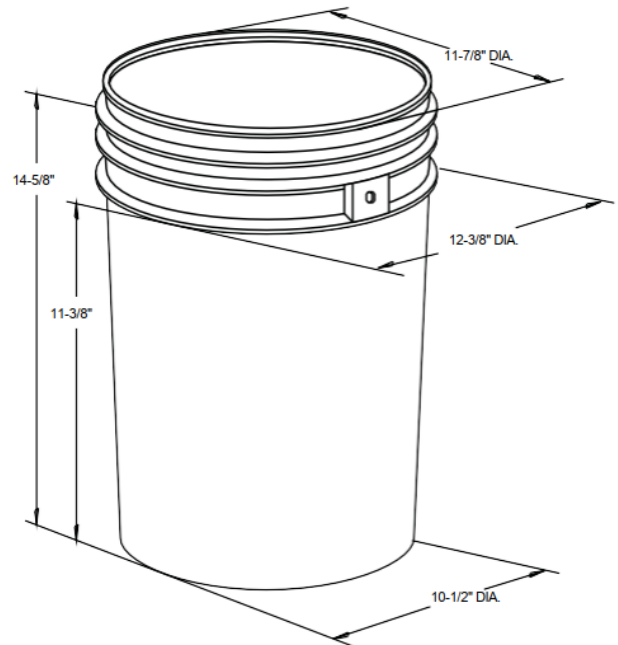

## Shipping Data

Qty. per pallet/carton: 144  
Gross Weight (lbs./kgs.)\*\*: 299.5/135.4  
Den. (lbs./C.F./kgs./m3): 5.7/90.3  
Length (in./cm.): 49.3/125.2  
Width (in./cm.): 37.5/95.3  
Height (in./cm.): 49.5/125.7  
Estimated truckload quantity of 6,336 bodies and covers\*\*\*

## Bodies

## Filled Containers

36 (12 per layer / 3 layers high)  
Pallet height: 48.8"

Notes: \*Bulk pack also available  
\*\*Weight does not include pallet/packaging  
\*\*\*Truckload quantity based on 53' trailer

## Materials

FDA approved materials  
Resin: Body: High-Density Polyethylene (HDPE)

## Optional Carrying Handle

### DISCLAIMER

THIS INFORMATION IS PROVIDED AS A GENERAL GUIDE, INCLUDING DIMENSIONS. IT IS THE CUSTOMER'S RESPONSIBILITIES TO SELECT THE PROPER CONTAINER FOR PRODUCT AND APPLICATION COMPATIBILITY.

DISTRIBUTED BY:



REF NO.:

DWG30201

DESCRIPTION:

5 Gallon HDPE OH Pail (ROPAK)