











ASSEMBLY INSTRUCTION

3228-15C(3A) FACTORY RUSTIC OAK FINISH METAL & POPLAR WRITING DESK

A Side Frame  4PCS	B Iron Bar  4PCS	C Top Panel  1PC	D Middle Shelf  2PCS
E Bottom Panel  2PCS	F Bolt-Small 1/4"X1-1/2"  16PCS	G Spacer 40X40X3mm  8PCS	H Lock Washer 1/4"  32PCS
I Flat Washer 1/4"*16mm  32PCS	J Allen Key 4mm  1PC	K Bolt-Large 1/4"X1-3/4"  16PCS	

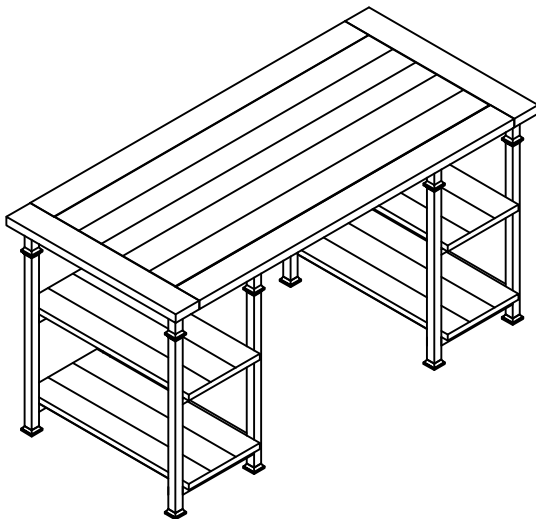

This page lists all the contents included in the box. Please take the time to identify the hardware as well as the individual components to this product. AS you unpack and prepare for assembly. place the contents on a carpeted or padded area to protect them from damage.

1 Attach Iron Bar (B) to the Side Frame (A) as below showing.

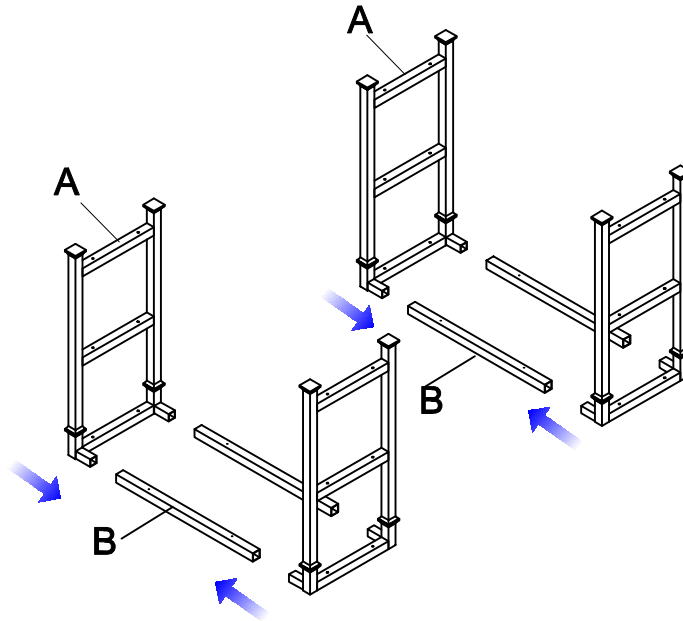

2 Attach the assembled Side Frame(A) to the Top Panel (C) by using Flat Washer (I), Lock Washer (H) and Bolt-Large (K) with Allen Key (J).

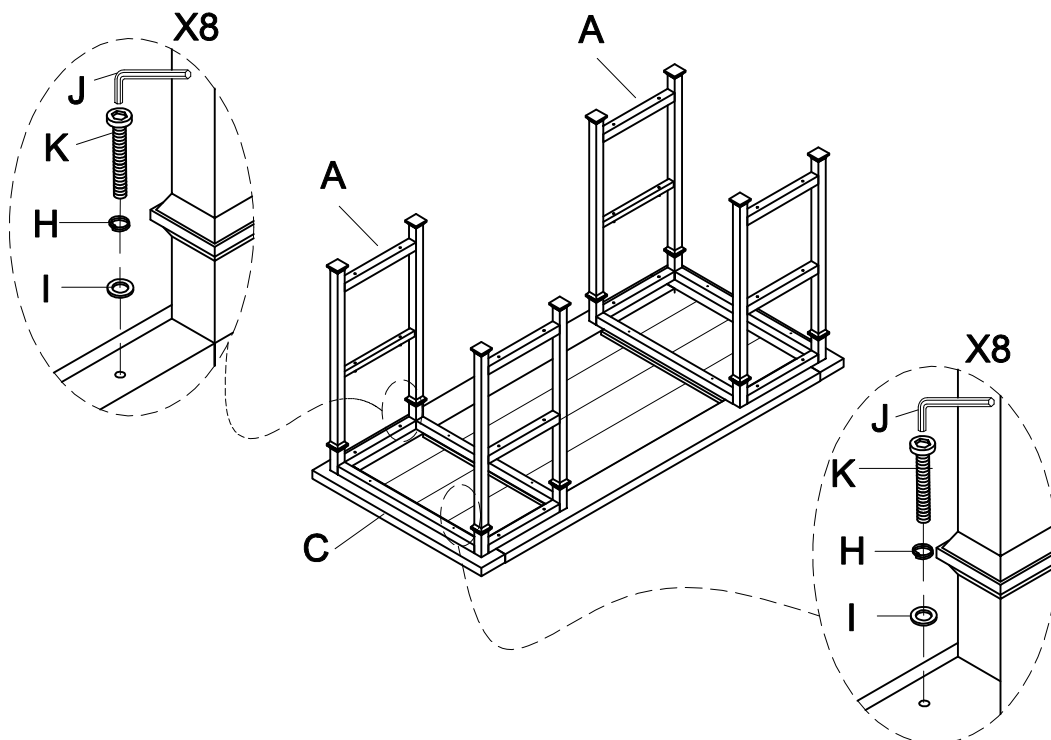

- 3** Attach the Middle Shelf (D) to the Side Frame (A) by using Flat Washer (I), Lock Washer (H) and Bolt-Small (F) with Allen Key (J).

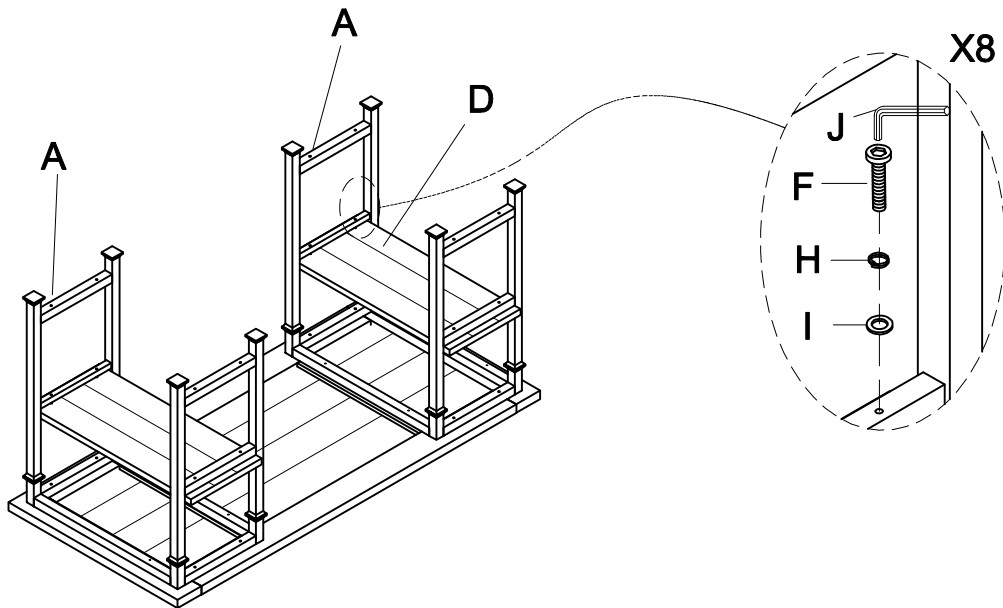

- 4** Attach the Bottom Shelf (E) to the Side Frame (A) by using Flat Washer (I), Lock Washer (H) and Bolt-Small (F) with Allen Key (J).

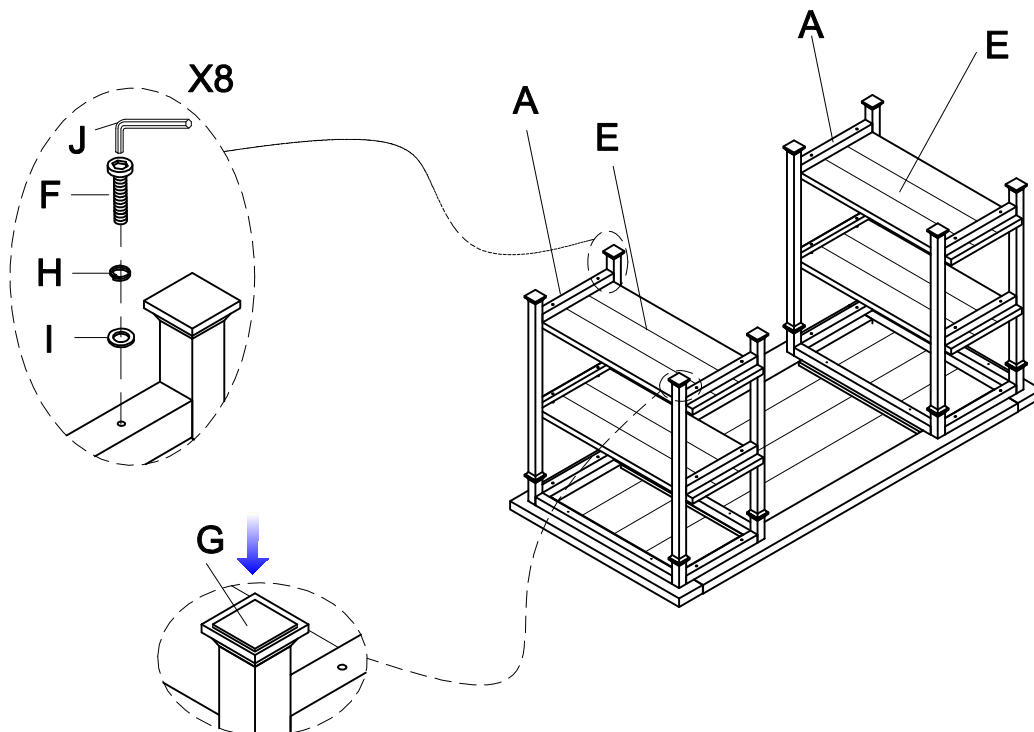





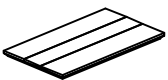
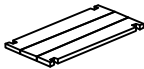
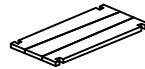
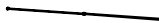

Cleaning & Care

Treat surface with care. Surface is resistant to scratches but is not scratch resistant. Clean surfaces with a dry or damp soft cloth. Do not use abrasive cleaners. Hardware may loosen over time. Periodically check that all connections are tight.

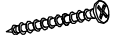
ASSEMBLY INSTRUCTION

3228-12(3A) METAL SUPPORTS BOOKCASE

A Top Panel  1PC	B Middle Shelf  3PCS	C Bottom Panel  1PC	D Cross Bar  2PCS
E Side Frame  2PCS	F Bolt-Small $\text{Ø}4 \times 3/4"$  4PCS	G Screw-Big $\text{Ø}4 \times 1-1/2"$  4PCS	H Bolt $5/32 \times 1/2"$  5PCS
I Spacer  4PCS	J Anti-Tipping Hardware Pack  a 1PC b 2PCS c 1PC d 1PC e 1PC		

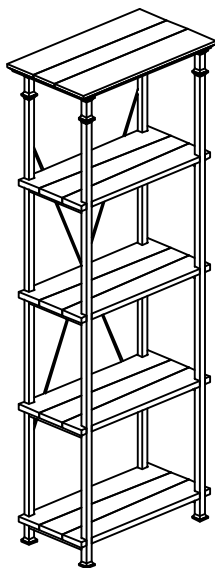

This page lists all the contents included in the box. Please take the time to identify the hardware as well as the individual components to this product. AS you unpack and prepare for assembly, place the contents on a carpeted or padded area to protect them from damage.

- 1** Attach the Side Frame (E) to the Top panel (A) by using Bolt-Small (F), and attached the Bottom Panel (C) to the Side Frame (E) as below drawing.

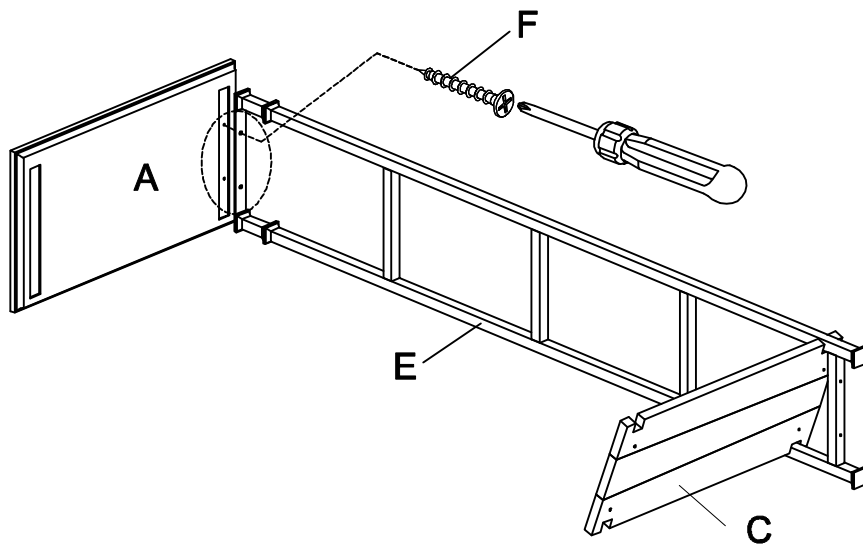

- 2** Attach another Side Frame (E) to the Top Panel (A) by using Bolt-Small (F), fixing the Bottom Panel (C) to Side Frame (E) by using Bolt-Big (G), and then attached the Spacer (I) to the bottom of the Side Frame (E).

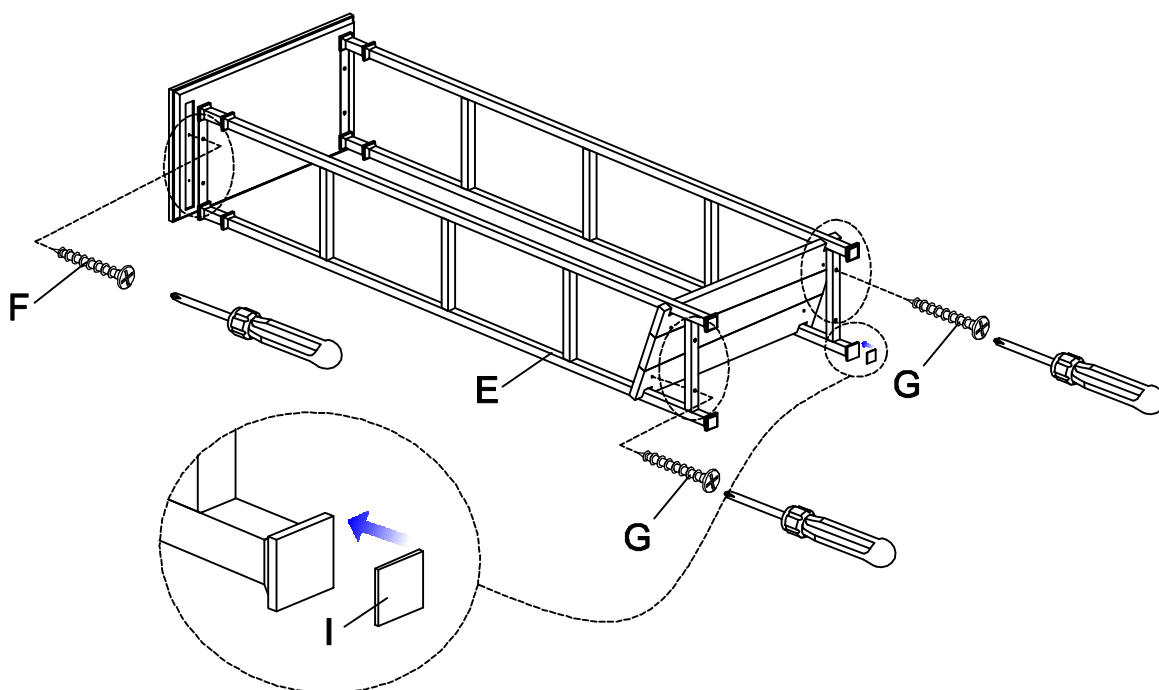

3 Attach the Middle Panel (B) to the Side Frame (E).

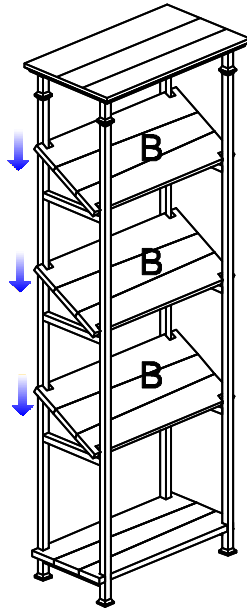

4 Attach the Cross Bar (D) to the back of the Side Frame (E) by using Bolt (H) and then fix the Cross Bar (D) with each other by using Bolt (H).

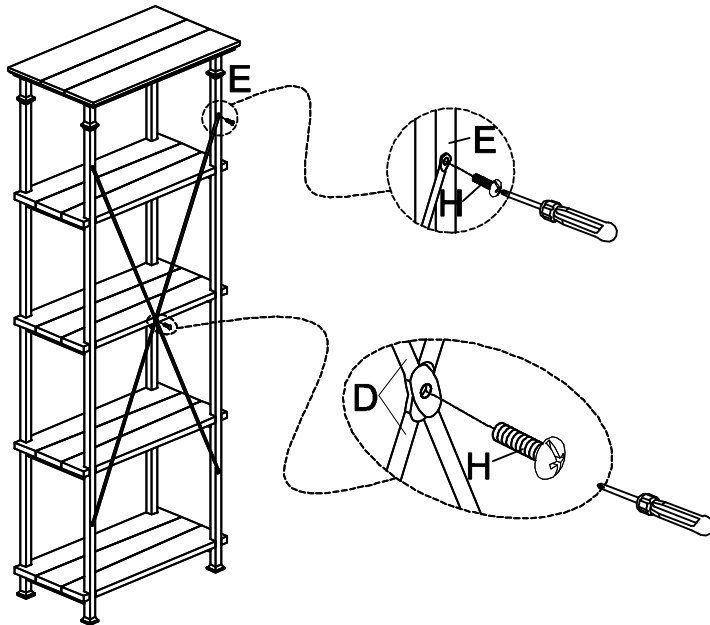

5 Take out the Anti-Tipping Hardware Pack (J) from the hardware set package, assemble it to avoid tipping.

1. Attach one of the wall brackets (b) and secure to the back top the back edge of the bookcase using the short screw (e).
2. Mark the location on the wall for mounting the second wall bracket (b). Create appropriate sized hole in the wall and insert the plastic screw anchor (c). Secure the bracket to the wall using the long screw (d).
3. Place the furniture to the bracket on the back edge of unit is line with the bracket on the wall.
4. Lace an end of the nylon strap (a) down through each bracket, check to make sure the strap is securely laced and locked to bracket.

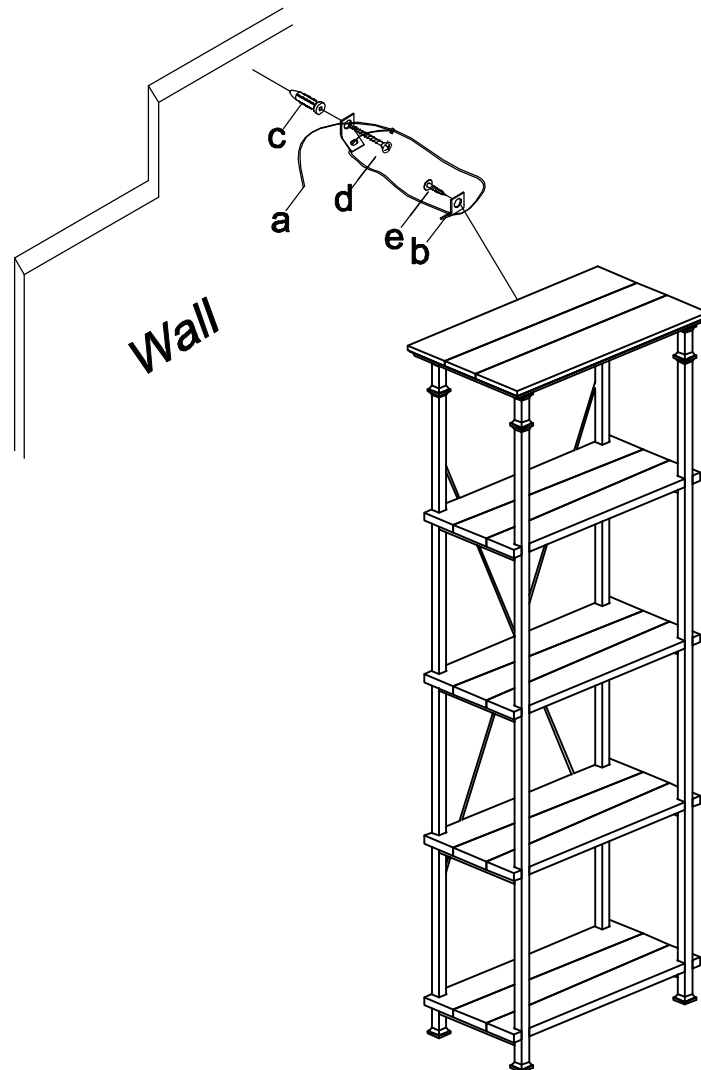

Cleaning & Care

Treat surface with care. Surface is resistant to scratches but is not scratch resistant. Clean surfaces with a dry or damp soft cloth. Do not use abrasive cleaners. Hardware may loosen over time. Periodically check that all connections are tight.