

ASSEMBLY INSTRUCTIONS

24" COUNTER HEIGHT STOOL

A Seat

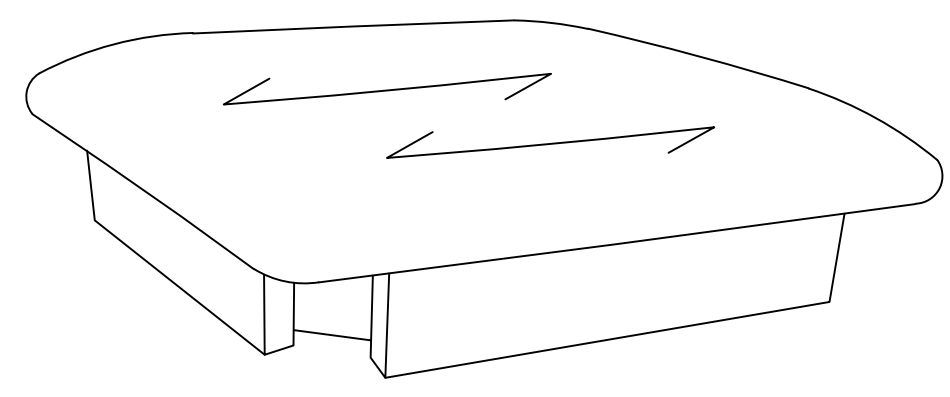

1 pc

B Leg Front Left

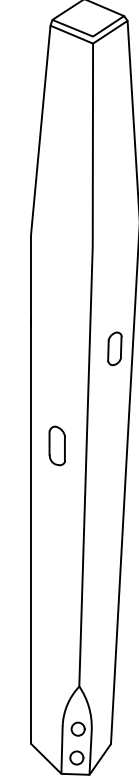

1 pc

C Leg Back Left

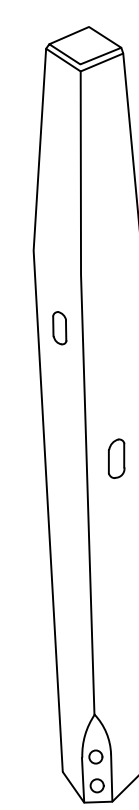

1 pc

D Leg Front Right

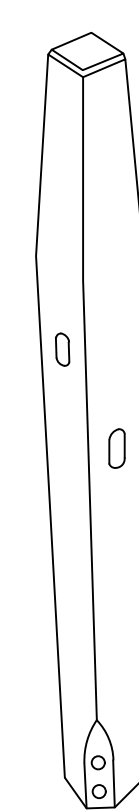

1 pc

E Leg Back Right

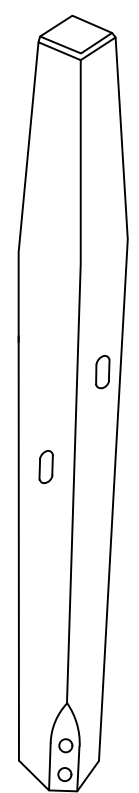

1 pc

F Strecher

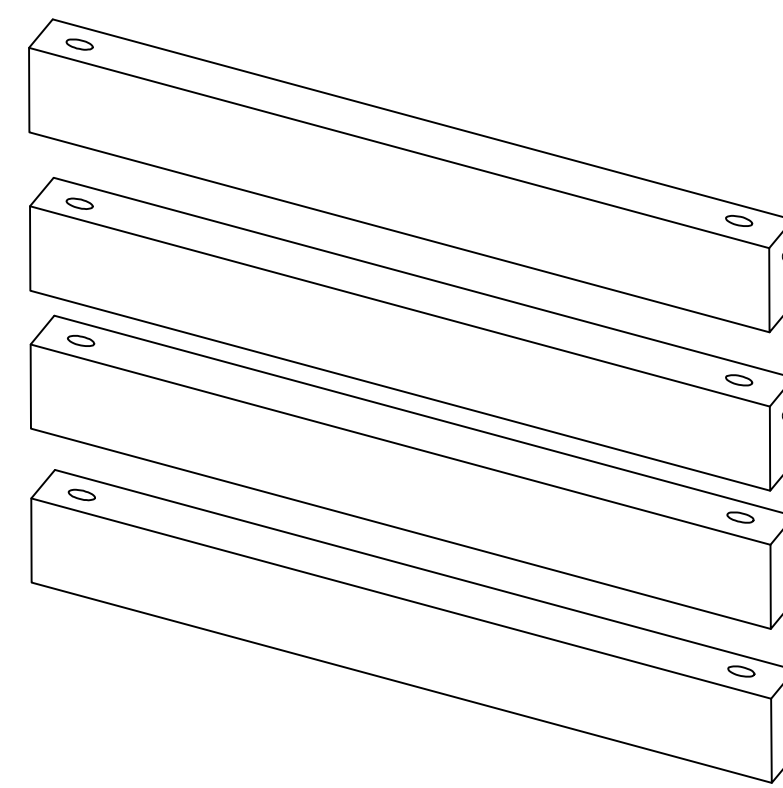

4 pcs

G JCBC Bolt
M6 x 60mm

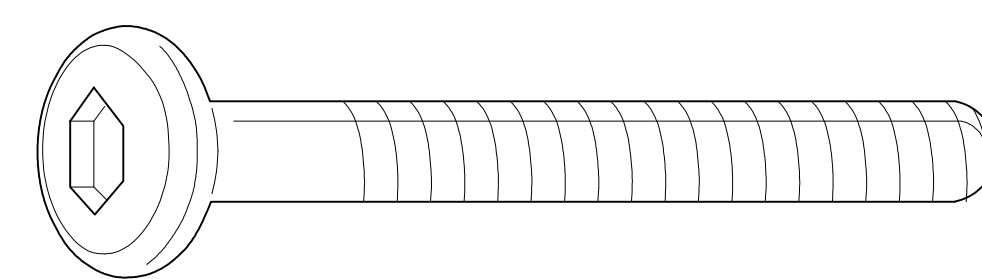

8 pcs

H Spring Washer
M6

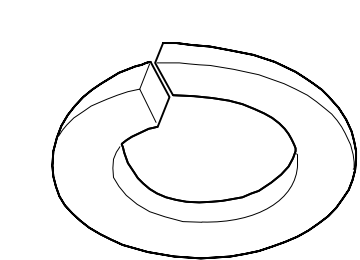

8 pcs

I Flat Washer
M6

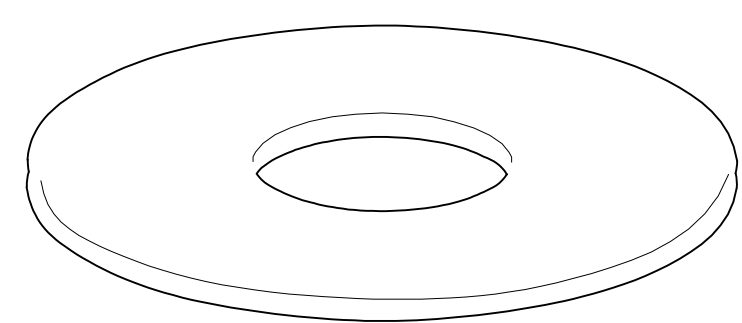

8 pcs

J Allen Key
M4 x 110mm

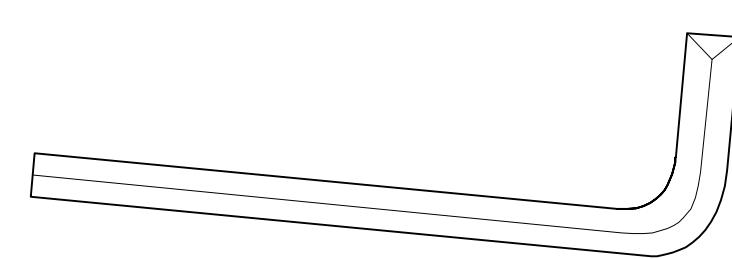

1 pc

K Pan Head Screw
M4 x 38mm

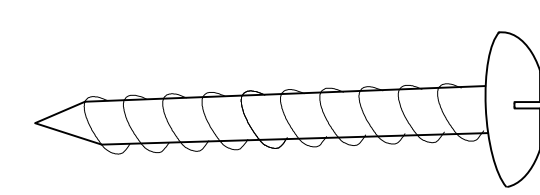

8 pcs

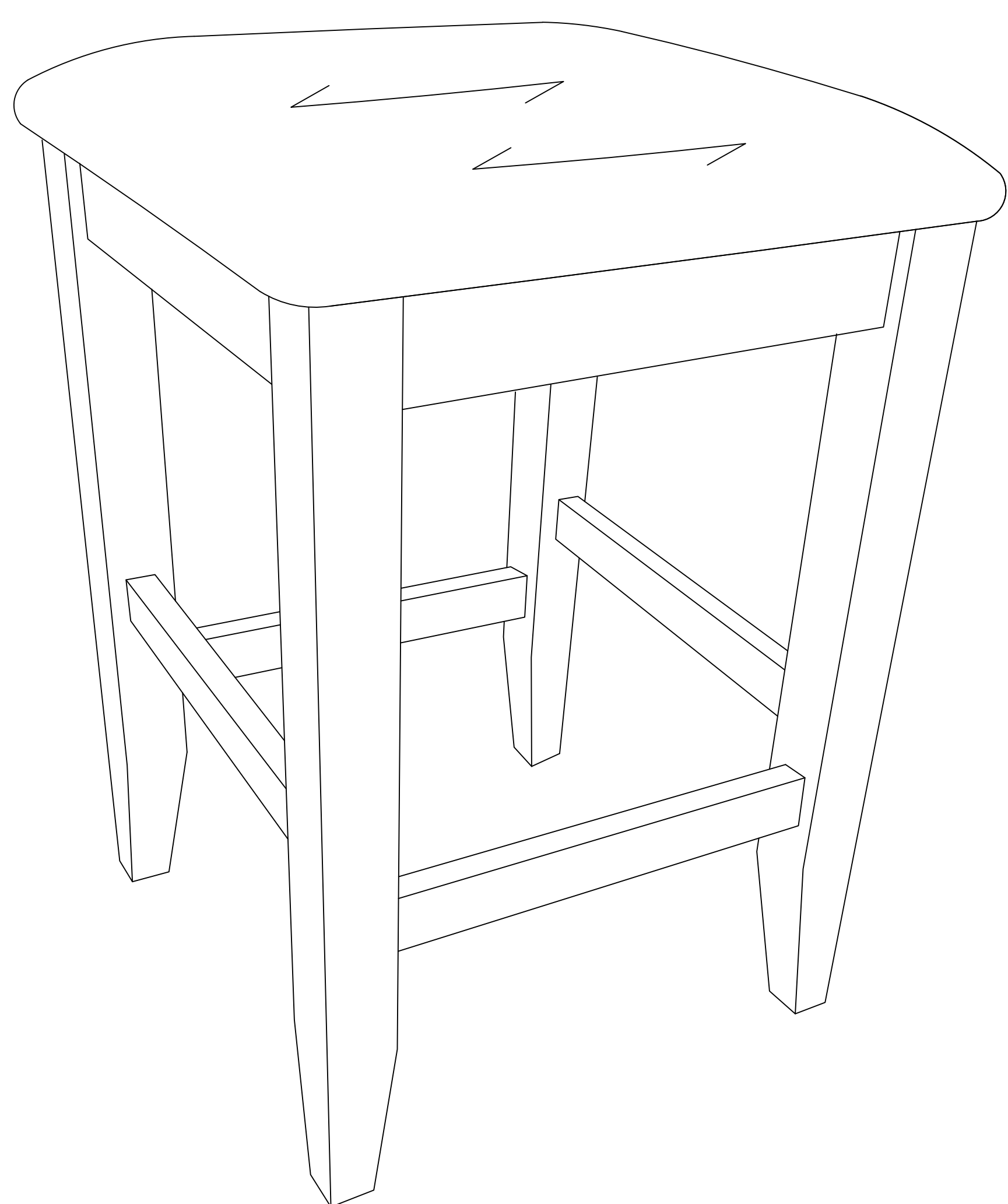

This page lists all the contents included in the box. Please take the time to identify the hardware as well as the individual components to this product. As you unpack and prepare for assembly, place the contents on a carpeted or padded area to protect them from damage.

1 Attach the Leg Back Right (E) to the Seat (A) using JCBC Bolt (G), Spring Washer (H) and Flat Washer (I) with the Allen Key (J).

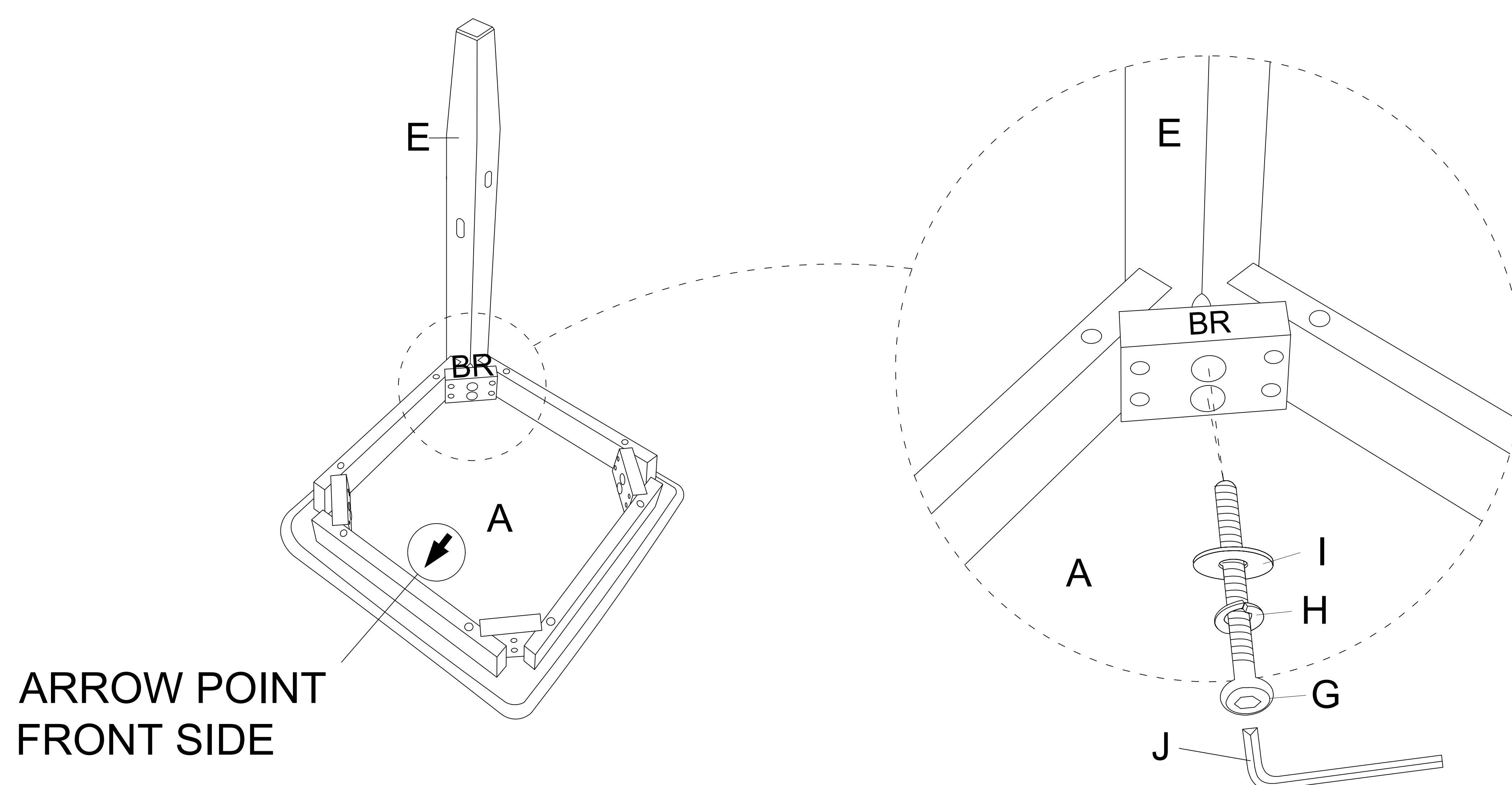

Take the Allen Key and turn the bolts until the legs are secured.
DO NOT TIGHTEN THE BOLTS COMPLETELY.
Stop when you feel you are adding force to tighten the bolts.

2 Attach the Leg Back Left (C) to the Seat (A) using JCBC Bolt (G), Spring Washer (H) and Flat Washer (I) with the Allen Key (J). Before tightening the bolts, attach the Strecher (F) between the Leg Back Left (C) & Leg Back Right (E).

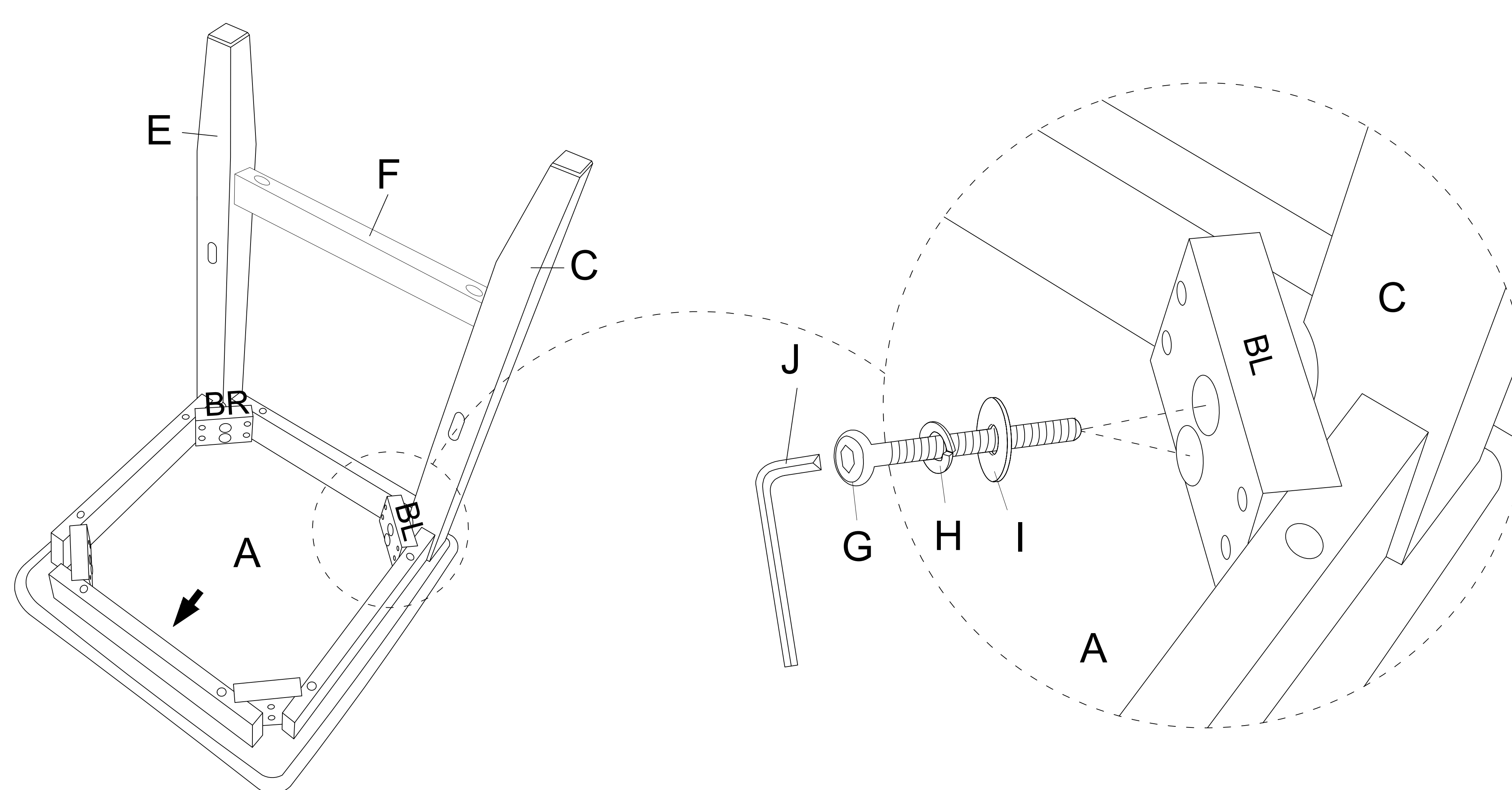

- 3** Attach the Leg Front Left (B) to the Seat (A) using JCBC Bolt (G), Spring Washer (H) and Flat Washer (I) with the Allen Key (J). Before tightening the bolts, attach the Strecher (F) between the Leg Front Left (B) & Leg Back Left (C).

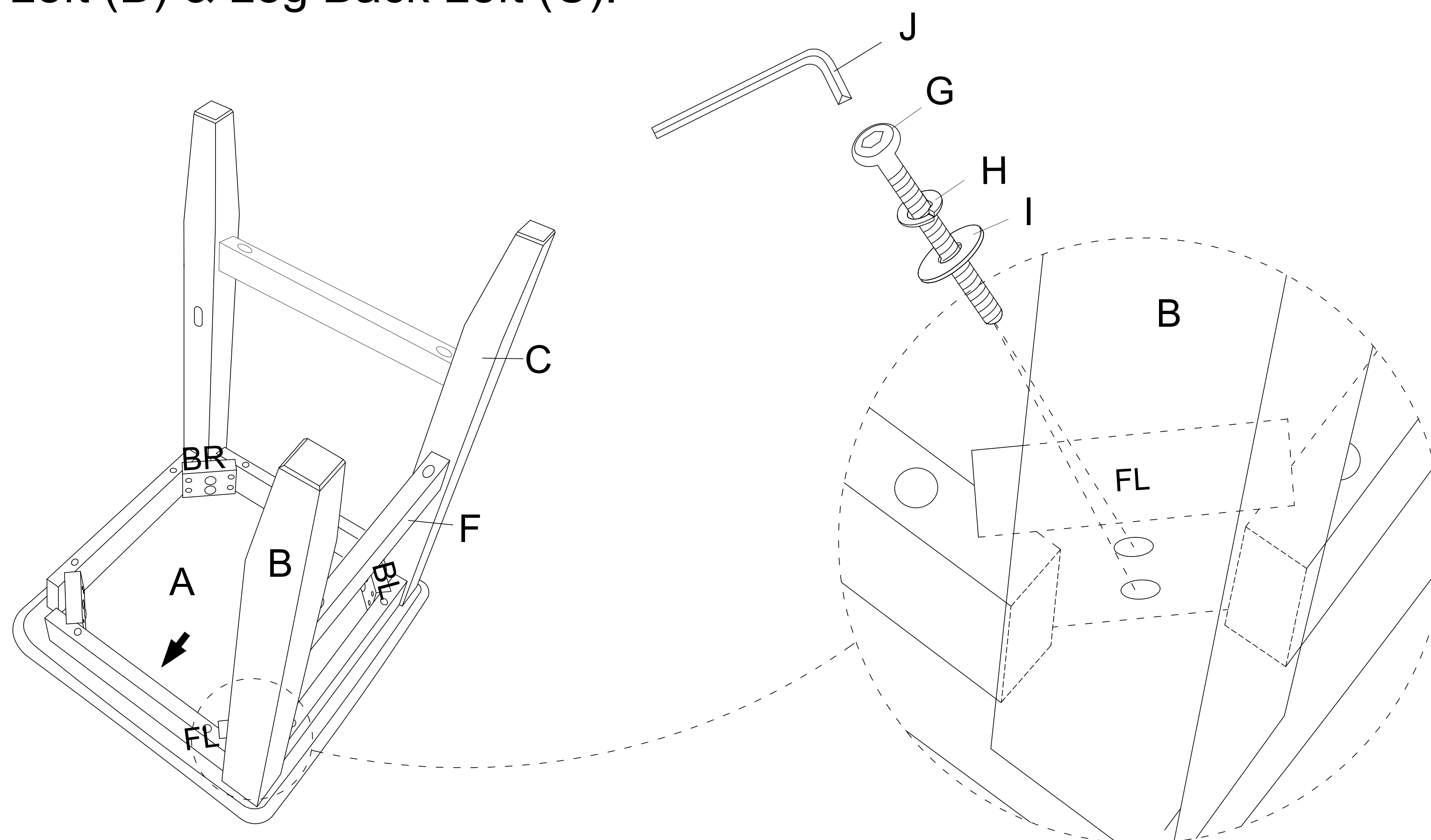

- 4** Attach the Leg Front Right (D) to the Seat (A) using JCBC Bolt (G), Spring Washer (H) and Flat Washer (I) with the Allen Key (J). Before tightening the bolts, attach the Strecher (F) between the Leg Front Left (B) & Leg Front Right (D) and Leg Front Right (D) & Leg Back Right (E). Finally, secure the Strecher (F) using Pan Head Screw (K) with a screwdriver (not provided).

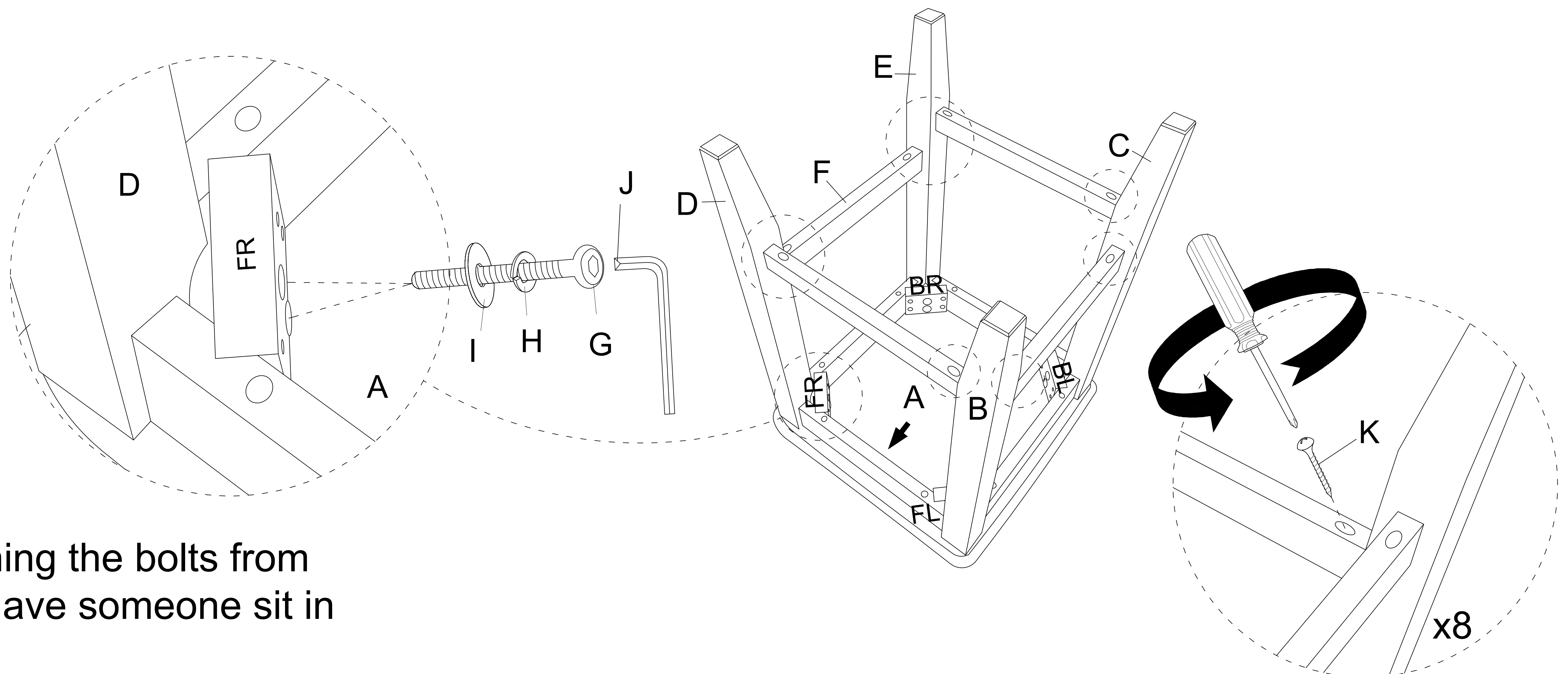

Helpful Tips

*While tightening the bolts from underneath, have someone sit in the stool.

Stand the stool on an even surface and check for balance. If the stool wobbles slightly, apply downward pressure on the uneven leg and tighten the bolts to correct the imbalance. Once the stool is balanced, apply downward pressure evenly in the center of the stool and tighten all bolts, being careful not to over-tighten beyond the hole depth.

Cleaning & Care

Treat surfaces with care. Surfaces are resistant to scratches but are not scratch resistant. Clean surfaces with a dry or damp soft cloth. Do not use abrasive cleaners. Hardware may loosen over time. Periodically check that all connections are tight.