

5.0 Gallon 90 mil LBR Pail with Tear Skirt Cover

Multiple Uses

UN-solids rated in US to Y27/S
 UN rated in Canada to Y30/S
 May also be used for non-hazardous liquids and solids

Product Codes

Container: **5500 Series, 55100**
 Description: 5.0 gallon 90 mil Pail

Cover: 6500 Series

Description: Standard Tear Skirt Cover
 Note: *Multiple fitting and venting options available

Features

Gauge: 90 mil.
 Nominal capacity: 5.0 USG / 19.0 L
 Stack performance: 350 lbs.*
 Tare weights: Body: 2.08 lbs. / .948 kgs
 Cover: .66 lbs. / .300 kgs.

Note: *Ratings will be reduced with uneven load distribution.

Specifications with Cover

Dimensions: 12-3/8" D X 14-11/16"H
 Maximum capacity: 5.3 USG / 20.2 L
 Tare weight: 2.74 lbs. / 1.25 kgs.

Colors

Standard: White, Black and Natural
 Custom: Available at manufacturer's discretion

Decorating Options

Four color offset printing
 Print area: 33"W x 8-1/2"H
 Sleeve or pressure sensitive labeling

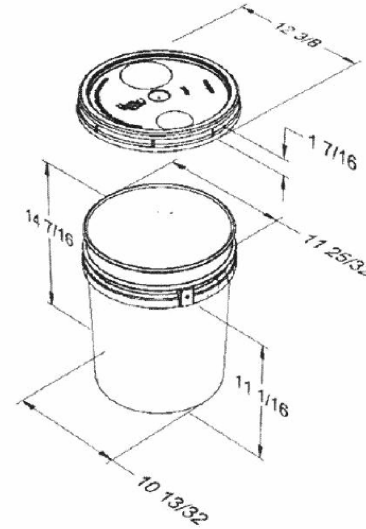

Shipping Data

Qty. per pallet/carton:
 Gross Weight (lbs/kgs.)**:
 Length (in./cm.):
 Width (in./cm.):
 Height (in./cm.):

Bodies

240*
 499 / 26
 48 / 122
 36 / 91.4
 45 / 114

Covers

1,200*
 792 / 359
 50 / 127
 37.5 / 95.3
 96 / 243.8

Filled Containers

36 (12 per layer / 3 layers high)
 Pallet Height: 47"

Estimated truckload quantity of 5,520 bodies and covers***

Notes: *Quantity can vary based on customer request
 **Weight does not include pallet/packaging
 ***Truckload quantity based on 53' trailer

Materials

FDA approved materials
 Resin: Body: High-Density Polyethylene (HDPE)
 Cover: High-Density Polyethylene (HDPE)

MSDS Sheets available upon request

Optional Carrying Handle

Wire or Plastic

DISCLAIMER

THIS INFORMATION IS PROVIDED AS A GENERAL GUIDE, INCLUDING DIMENSIONS. IT IS THE CUSTOMER'S RESPONSIBILITIES TO SELECT THE PROPER CONTAINER FOR PRODUCT AND APPLICATION COMPATIBILITY.

DISTRIBUTED BY:



REF NO.:

DWG10134

DESCRIPTION:

5 Gallon HDPE Straight Sided Pail

Additional dimensions

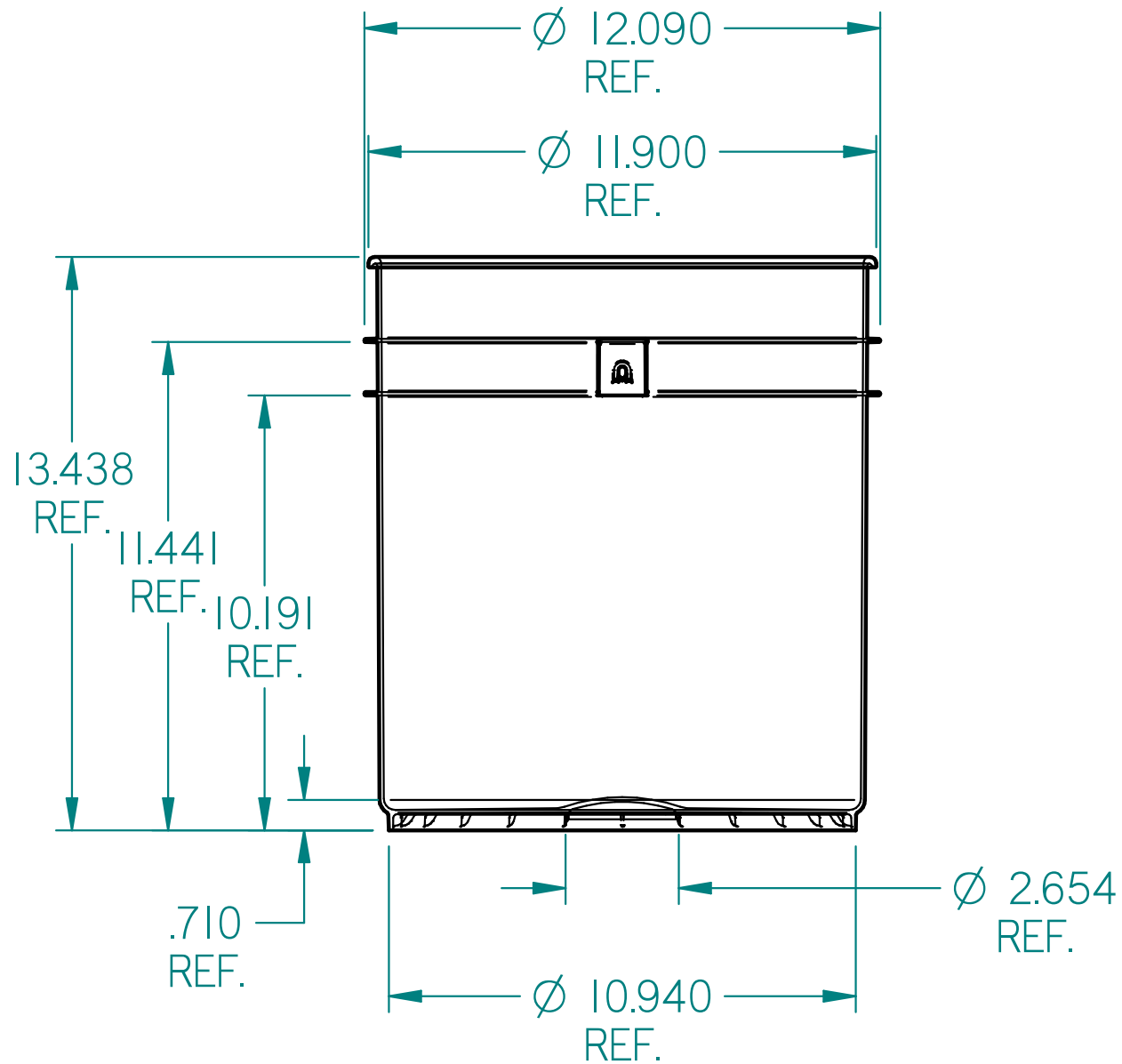

DISCLAIMER

THIS INFORMATION IS PROVIDED AS A GENERAL GUIDE, INCLUDING DIMENSIONS. IT IS THE CUSTOMER'S RESPONSIBILITIES TO SELECT THE PROPER CONTAINER FOR PRODUCT AND APPLICATION COMPATIBILITY.

DISTRIBUTED BY:



REF NO.:

DWG10134

DESCRIPTION:

5 Gallon HDPE Straight Sided Pail