



PRESTIGE[®]

Owner's Manual

P500VX

Grills illustrated in this manual may differ from model purchased.

We Want Your Feedback!
Visit Napoleon.com to write a review



Apply Serial Number





CONGRATULATIONS ON YOUR NAPOLEON® GRILL!

You've Just Upgraded Your Grilling Game.



OUR GOAL IS TO MAKE YOUR GRILLING EXPERIENCE BOTH MEMORABLE AND SAFE.

 Please read this Owner's Manual before using the appliance to avoid property damage, personal injury, or death.

 Remove all packaging material, promotional labels and cards from the grill before use.

USE OUTDOORS IN A WELL-VENTILATED SPACE.

DANGER!

IF YOU SMELL GAS:

- Shut off gas to the appliance.
- Extinguish any open flame.
- Open lid.
- If odor continues, keep away from the appliance and immediately call your gas supplier, or fire department.

WARNING!

Do not try to light this appliance without reading the "LIGHTING" instructions section of this manual.

Do not store or use gasoline, or other flammable liquids or vapors in the vicinity of this or any other appliance.

An L.P. (propane) cylinder not connected for use must not be stored in the vicinity of this or any other appliance.

If the information in these instructions is not followed exactly, a fire or explosion may result and cause property damage, personal injury, or death.



Alert adults and children about the hazard of hot surface temperatures.



Supervise young children near the grill.

NOTICE TO INSTALLER: Leave these instructions with the grill owner for future reference.

NOTICE TO CONSUMER: Keep these instructions for future reference.

Welcome to NAPOLEON®!

Safety First

WARNING!

General Information

The appliance shall be connected in accordance with national regulations and local codes. If a rotisserie motor is used, it must be electrically grounded in accordance with local codes. If an external electrical source is utilized, the appliance must also be grounded in accordance with local codes.

WARNING!

Operation

Leak test this grill before each use, annually and when any gas components are replaced.

Follow the lighting instructions carefully. Do not let the cord hang over the edge of a table. Do not use this grill for purposes other than intended.

Do not operate this grill with a damaged cord, plug, or after the grill malfunctions or has been damaged in any manner. Contact your authorized Napoleon® dealer for repair.

WARNING!

Installation & Assembly

Assemble this grill exactly as instructed in the Assembly Guide. If the grill was assembled in-store, review the assembly instructions to ensure it is done correctly. This grill is not intended to be installed in or on boats or installed in or on recreational vehicles.

Perform the required Leak Test before operating the grill. Do not modify this grill under any circumstances. Allow grill to cool before installing or removing parts.

Do not use a cylinder that is not equipped with the appropriate type of connection.

Only use the pressure regulator and hose assembly supplied with this grill or replacement parts specifically recommended by Napoleon®.

WARNING!

Storage & Disuse

Turn off gas at the gas cylinder or natural gas supply valve. Disconnect the hose between the gas cylinder and grill. Remove the gas cylinder and store outdoors in a well-ventilated space away from children.

Unplug from the outlet when not in use and before cleaning. DO NOT store gas cylinders in a building, garage, shed, or any other enclosed space. Disconnect the natural gas hook-up from the supply when storing the grill indoors.

Place dust cap on cylinder valve outlet whenever the cylinder is not in use. Only install the type of dust cap on the cylinder valve outlet that is provided with the cylinder valve. Other types of caps or plugs may result in leakage of gas.

WARNING!

Correct Product Disposal



This marking indicates that this product should not be disposed with other household wastes throughout the EU. To prevent possible harm to the environment or human health from uncontrolled waste disposal, recycle it responsibly to promote the sustainable reuse of material resources. To return your used device, please use the return and collection systems or contact the retailer where the product was purchased. They can take this product for environmental safe recycling.

Refer to the assembly guide for replacement part identification and installation information.

CONTENTS

Welcome to NAPOLEON®!	3
Full System Features	5
Getting Started	6
Additional Safe Operating Practices	6
Locating Your Grill	7
Gas Connections	8
Technical Data	10
Leak Test	11
Operation	12
Lighting Your Grill	12
Grilling Instructions	14
How to Use the Rotisserie	16
The Grilling Experience Checklist	17
How to Season Cast Iron Cooking Grids (if equipped)	17
Quick Start Instructions	18
Napoleon Connectivity	19
ACCU-PROBE® Cook Assist	21
Display Operation	22
System Monitoring	23
Safeguards	24
Clearance	24
Storage	24
Infrared Grilling Guide	25
Cleaning Instructions	26
Maintenance Instructions	30
General Requirements	30
Combustion Air Adjustment	30
Stainless In Harsh Environments	31
Troubleshooting	33
Compliance	37
Warranty	38

Full System Features

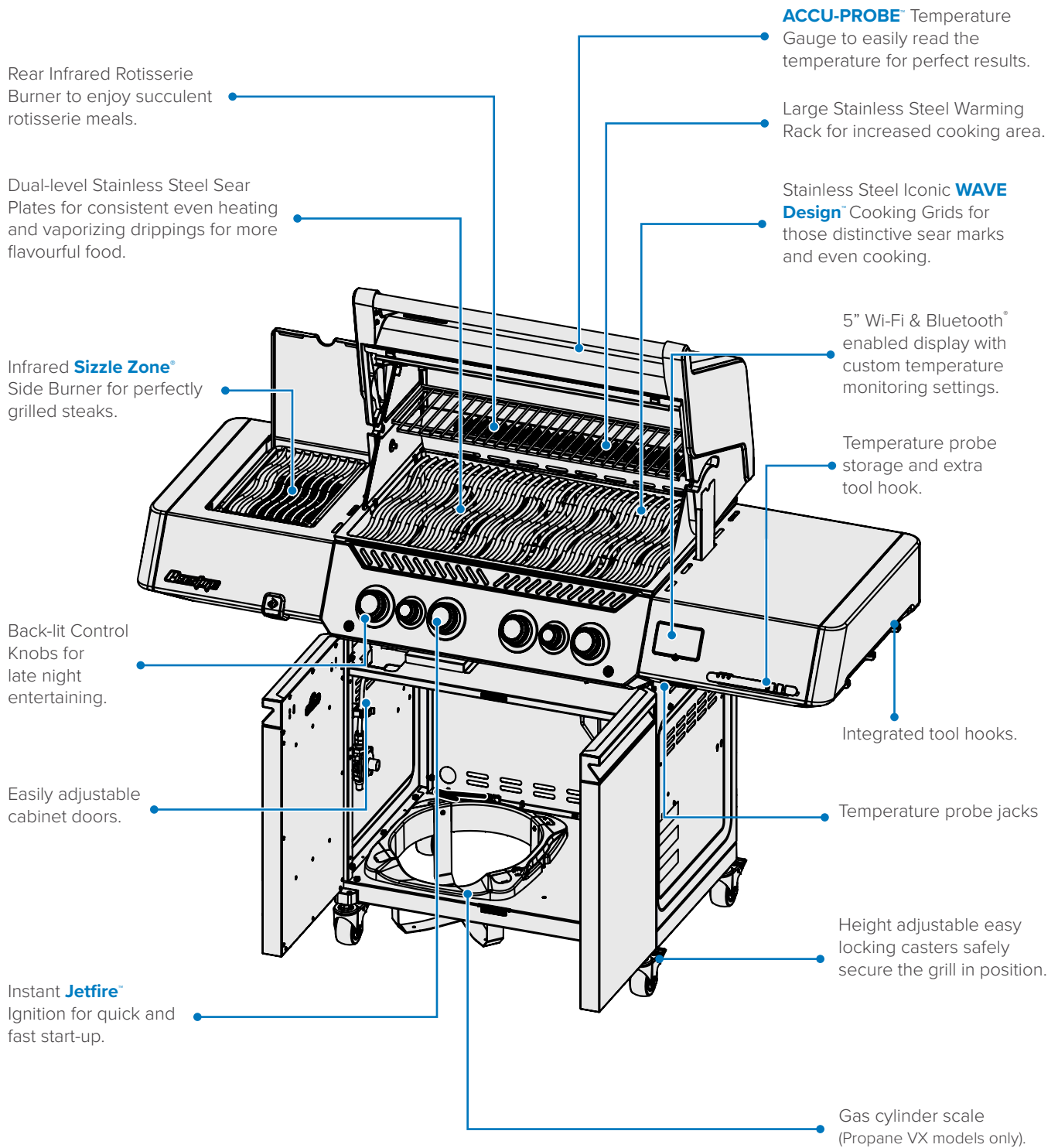

 The grills illustrated in this Owner's Manual may differ from the model you purchased. Featured model: P500VX

Getting Started



DANGER! Advises of a hazard that could result in a fire, explosion, death or serious physical injury.



WARNING! Advises of a hazard that could result in minor physical injury or property damage.



Wear protective gloves.



Wear safety glasses.



CAUTION! Hot surface.



Important Information.



Do not smoke while performing a gas leak test. Sparks or flames will cause a fire, explosion, damage to property, serious physical injury, or death.



Never use an open flame to check for gas leaks. Sparks or flames will cause a fire, explosion, damage to property, serious physical injury, or death.



Immediately shut off the gas supply and disconnect.

Additional Safe Operating Practices

- Do not route the hose underneath the drip pan. Maintain proper hose clearance to the bottom of the unit.
- Ensure sear plates are positioned properly according to sear plate installation instructions.
- Burner controls must be off when turning the gas cylinder valve on.
- Do not light burners with the lid closed.
- Do not operate the rear burner(s) with the main burners.
- Do not close the side burner lid when operating or hot.
- Do not deep fry food on the side burner.
- Do not adjust the cooking grids when operating or hot.
- Do not move the appliance during use.
- Turn off the gas supply at the source after use.
- Do not modify the appliance.
- Maintenance should only be done when the grill is cool.
- Do not store lighters, matches or any other combustibles inside the enclosure or condiment tray.
- Keep all electrical supply cords and fuel supply hoses away from all heated surfaces.
- Clean the grease tray, drip pan, and sear plates regularly to avoid build-up and grease fires.
- Keep the infrared burner and main burner venturi tubes free from spider webs and other obstructions by inspecting and cleaning it regularly.
- Do not allow cold water (rain, sprinkler, hose etc.) to contact the heated grill. An immediate temperature change will chip the porcelain and crack the ceramic burners.
- Do not use a pressure washer to clean any part of the grill.
- Do not locate this grill where it can be exposed to high winds, especially when the wind can come from directly behind the grill.
- Ensure a safe distance from flammable constructions when using the appliance.
- Never cover more than 75% of the cooking surface with solid metal.
- This appliance must be kept away from flammable materials while in use.
- Always maintain proper clearances to combustibles: 27" (68.6cm) to the rear of the appliance, and 7" (17.8cm) to the sides.
- The minimum ambient operating temperature for safe use of the appliance is 0 °F (-17.8 °C).



WARNING!

- The hook-up and installation of the gas and hose connection must be performed by a licensed gas fitter, and leak tested before operating the grill.
- Ensure the hoses do not contact any high temperature surfaces of the grill.
- Accessible parts may be very hot. Keep young children away.
- Keep fuel supply hoses away from any heated surfaces, sharp edges, or dripping grease.



BE CAREFUL!

The lid of the grill and the entire firebox can become very hot when in use.

Locating Your Grill

It is important when selecting a location for your gas grill to ensure clearances to adjacent combustibles are met. This appliance is intended for installation on an outdoor patio or in your yard.

- This appliance shall only be used in an above ground open-air situation with natural ventilation, without stagnant areas, where gas leakage and products of combustion are rapidly dispersed by wind and natural convection.
- Do not use in a building, garage, or any other enclosed area.
- Do not incorporate the appliance into any built-in or slide-in construction. Do not obstruct any cylinder enclosure ventilation openings.
- Do not obstruct any cylinder enclosure ventilation openings. 27" (68.6cm) to the rear of the appliance, and 7" (17.8cm) to the sides.

Any enclosure in which the appliance is used shall comply with one of the following:

- An appliance is considered to be outdoors if installed with shelter no more inclusive than with walls on three sides, but with no overhead cover. **(Fig 1)**
 - » All openings must be permanently open.
 - » Sliding doors, garage doors, windows, or screened openings are **not considered** as permanent openings.
- An appliance is considered to be outdoors if installed with shelter no more inclusive than within a partial enclosure that includes an overhead cover and no more than two sidewalls.
 - » The sidewalls may be parallel, as in a breezeway, or at right angles to each other. **(Fig 2 & Fig 3)**
 - » All openings must be permanently open.
 - » Sliding doors, garage doors, windows, or screened openings are **not considered** as permanent openings.
- An appliance is considered to be outdoors if installed with shelter no more inclusive than within a partial enclosure that includes an overhead cover and three sidewalls, as long as 30% or more of the horizontal periphery of the enclosure is permanently open. **(Fig 4 & Fig 5)**
 - » All openings must be permanently open.
 - » Sliding doors, garage doors, windows, or screened openings are **not considered** as permanent openings.

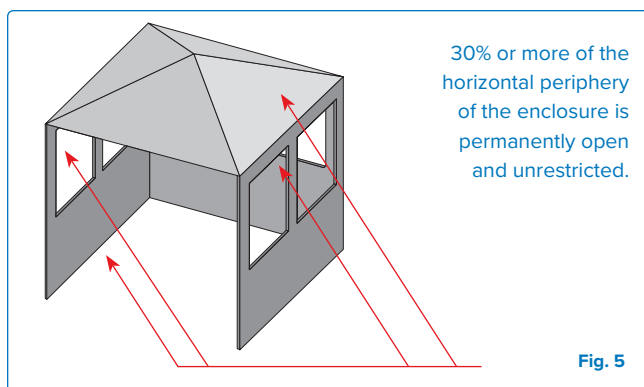
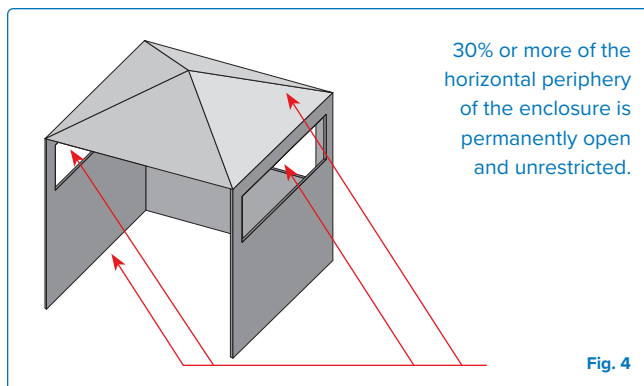
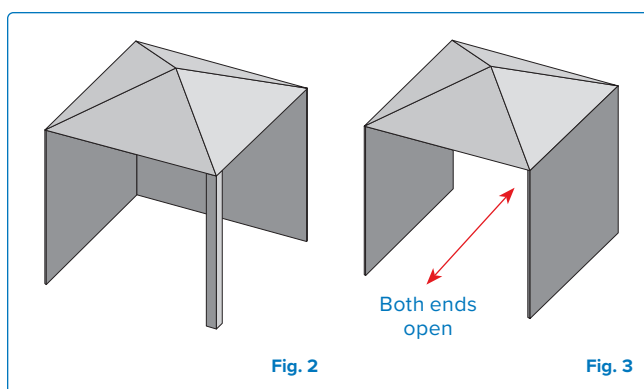
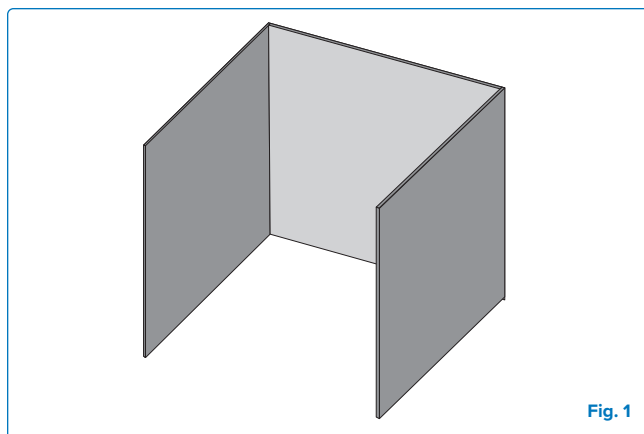

Gas Connections

To a Gas Cylinder: Option 1

Use a propane cylinder of minimum 6 kg or a butane cylinder of 13 kg constructed and marked in accordance with national and regional codes. Ensure that the cylinder can provide enough fuel to operate the appliance. If in doubt, check with your local gas supplier.

Use a gas pressure regulator and hose supplied by Napoleon; if not included, use a regulator and hose that meet European Norm and regional codes. The recommended length of the hose is 0.9 m. The hose must never be longer than 1.5 m.

NOTE: The hose should be replaced before the expiry date printed on it.

Only place cylinders within the maximum width and height dimensions inside the enclosure on the bottom shelf. Cylinders that surpass the maximum dimensions must be placed outside the enclosure on level ground. Refer to the diagram below for specific measurements.

Hook-up and Installation

- Check the cylinder for dents or rust, and have it inspected by your gas supplier.
- Never use a cylinder with a damaged valve.
- Place the cylinder in its designated area on the bottom shelf.
- Ensure the gas regulator hose has no kinks.
- Remove the cap or plug from the cylinder fuel valve.
- Tighten the regulator to the cylinder valve.
- Ensure the hose does not contact with the drip pan or any high temperature surfaces of the grill because it will melt and cause a fire.
- Ensure the cylinder is not left exposed to extreme heat or direct sunlight.
- Leak test all joints prior to operating the grill. See **“Leak Test”**.
- The cylinder must be mounted so that the pressure relief valve (if equipped) is not oriented toward the normal operating position of the user.

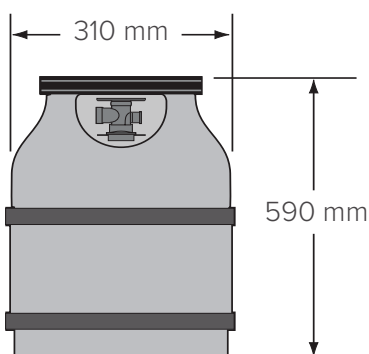
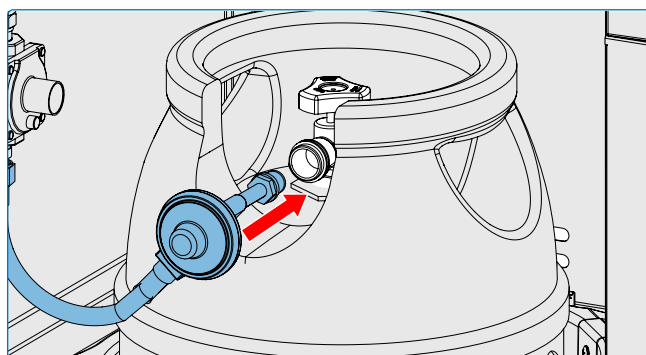
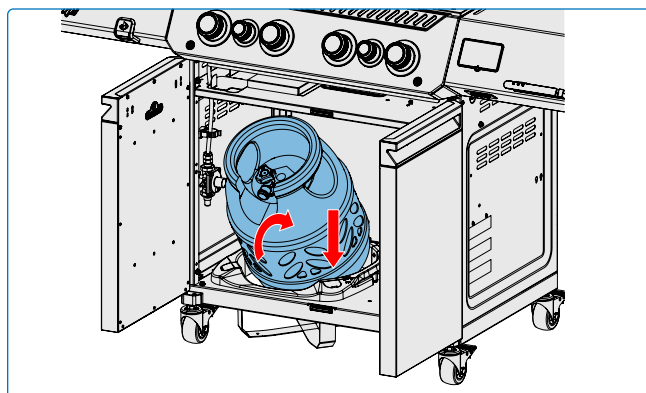
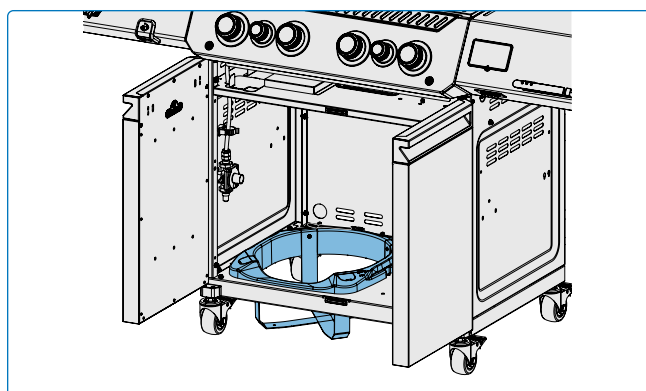

WARNING!

- Do not store a spare gas cylinder under or near the appliance.
- Follow all specifications and instructions precisely to prevent fire, explosion, property damage, personal injury, or death.
- Disconnect the grill and its individual shutoff valve from the gas supply piping system during any pressure testing in excess of ½ psi (3.5 kPa).
- Do not use a gas cylinder that is more than 80% full.
- Position the flexible tube such that it is not subjected to twisting.



NOTE: Inspect the LP gas cylinder valve seal for cracks, wear, or deterioration each time the cylinder is replaced or refilled.

Any LP gas cylinder showing signs of damage or deterioration, including visible cracks and pitting, must be returned unused to the seller.

Replacement

The entire process of changing the gas cylinder must be done away from any sources of ignition.

1. Close the cylinder fuel valve.
2. Detach the regulator from the cylinder valve.
3. Remove the cylinder from the bottom shelf and replace with a new cylinder.
4. Follow Hook-up instructions.

To a House Gas Supply Line: Option 2

- If the grill is to be connected directly to a house gas supply line, disconnect and discard the supplied hose and regulator assembly and follow house gas supply line hook-up instructions. An approved hose is available from your Napoleon grill dealer.
- Before installation, ensure that the local distribution conditions (identification of the type of gas and pressure) and the adjustment of the appliance are compatible.
- An isolation valve (or valves) must be fitted adjacent to the appliance which, when closed, allow the complete burner and control assembly to be disconnected for maintenance or repair in accordance with national regulations.
- A gas supply hose and quick disconnect designed for natural gas and certified for outdoor use are available for natural gas grills.
- Gas plumbing must supply the appropriate pressure to the inlet of the grill. See Technical Data for specifications.
- Piping and valves upstream of the quick disconnect are not supplied.
- The gas pipe must be sized to supply the heat input specified on the rating plate, based on the length of the piping run.
- Gas connection size (Internal regulator): 11/16" (1.75 cm).

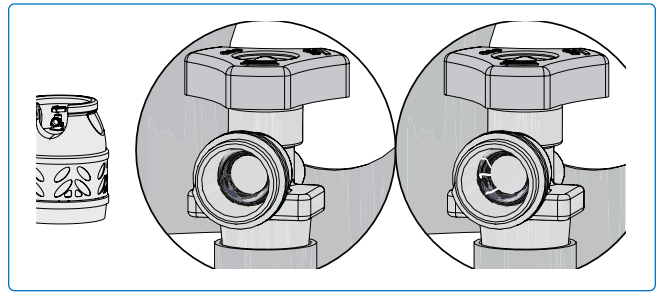

1. Hook-up to a gas supply line must be performed by a licensed gas fitter and leak tested before operating the grill.
2. Do not route the hose in close proximity to the drip pan or over top of the back panel.
3. Ensure the hose does not contact any high temperature surfaces.

Quick Disconnect

- Do not install the quick disconnect in an upward direction.
- A readily accessible manual shut-off valve must be installed upstream of the quick disconnect, and as close to it as possible.
- Connect the flared end of the hose to the fitting on the end of the manifold tube or flex tube (if applicable).
- Tighten using two wrenches. Do not use thread sealer or pipe dope.
- Leak test all joints prior to operating the gas grill. See **"Leak Test"**.



WARNING!

- Close the individual shutoff valve to isolate the grill from the gas supply piping system during any pressure testing equal to or less than ½ Psi (3.5 kPa).
- Check the hose for evidence of excessive abrasion, melting, cuts or cracks. If the hose is damaged, it must be replaced with an assembly specifically recommended by Napoleon®.



BE CAREFUL!

The lid of the grill and the entire firebox can become very hot when in use.

Technical Data

The following table lists gross heat input, gas usage values and orifice sizes corresponding to each burner per Gas Category:

		Orifice Size		Gross Heat Input (Total)		Gas Usage (Total)	
		I	II	I	II	I	II
P500V(X)	Main	#60	1.40 mm	16.0 kW G30 14.0 kW G31	16.0 kW	1164 g/h	1525 L/h
	Rear	1.25 mm	#50	5.7 kW G30 5.0 kW G31	5.7 kW	415 g/h	543 L/h
	Side	#56	1.65 mm	5.0 kW G30 4.5 kW G31	5.0 kW	364 g/h	476 L/h
P665V(X)	Main	#60	1.40 mm	20.0 kW G30 17.5 kW G31	20.0 kW	1455 g/h	1906 L/h
	Rear	1.25 mm	#50	5.7 kW G30 5.0 kW G31	5.7 kW	415 g/h	543 L/h
	Side	#56	1.65 mm	5.0 kW G30 4.5 kW G31	5.0 kW	364 g/h	476 L/h

The following table lists all certified gases and pressures. Verify the information on the rating plate corresponds with this list.



NOTE: Only use regulators that supply the pressure listed here.

Gas Category	3P(30)	3P(37)	3P(50)	3B/P(30)	3+(28-30/37)	3B/P(50)	2H	2E
Orifice Sizes	I	I	I	I	I	I	II	II
Gases / Pressures	G31 at 30 mbar	G31 at 37 mbar	G31 at 50 mbar	G30/G31 at 30 mbar	G30 at 28-30 mbar/ G31 at 37 mbar	G30/G31 at 50 mbar	G20 at 20 mbar	G20 at 20 mbar
Countries	FI, NL, RO	BE, CH, CZ, ES, FR, GB, GR, HR, IE, IT, LT, NL, PL, PT, SI, SK	AT, CH, CZ, DE, GR, NL, SK	BE, BG, CY, DK, EE, FI, FR, GB, GR, HR, HU, IT, LT, MT, NL, NO, RO, SE, SI, SK, TR	BE, CH, CY, CZ, ES, FR, GB, GR, IE, IT, LT, PT, SI, SK, TR	AT, CH, DE, FR, SK	AT, BG, CH, CZ, DK, EE, ES, FI, GB, GR, HR, IE, IT, LT, LV, NO, PT, RO, SE, SI, SK, TR	DE, LU, PL, RO



WARNING!

- Check the hose for evidence of excessive abrasion, melting, cuts or cracks. If the hose is damaged, it must be replaced with an assembly specifically recommended by Napoleon®.

Leak Test

Why and When to Leak Test?

A leak test confirms no gas is escaping after you connect the hose to the gas supply.

Each time the tank is refilled and reinstalled, ensure that there are no leaks in the fitting where the regulator connects to the tank.

Leak test this grill before use, annually, and when any gas components are replaced.

Leak Test Steps

1. Do not smoke while performing the test.
2. Remove all sources of ignition.
3. Turn all burner controls to the off position.
4. Turn the gas supply valve on.
5. Brush a half-and-half solution liquid soap and water onto all joints and connections of the regulator, hose, manifolds, and valves.
6. Bubbles indicate a gas leak.

If you Find a Leak

1. Tighten any loose joints.
2. If the leak cannot be stopped, immediately shut off the gas supply and disconnect the grill.
3. Have the grill inspected by a certified installer, or dealer.
4. Do not use the grill until the leak has been fixed.

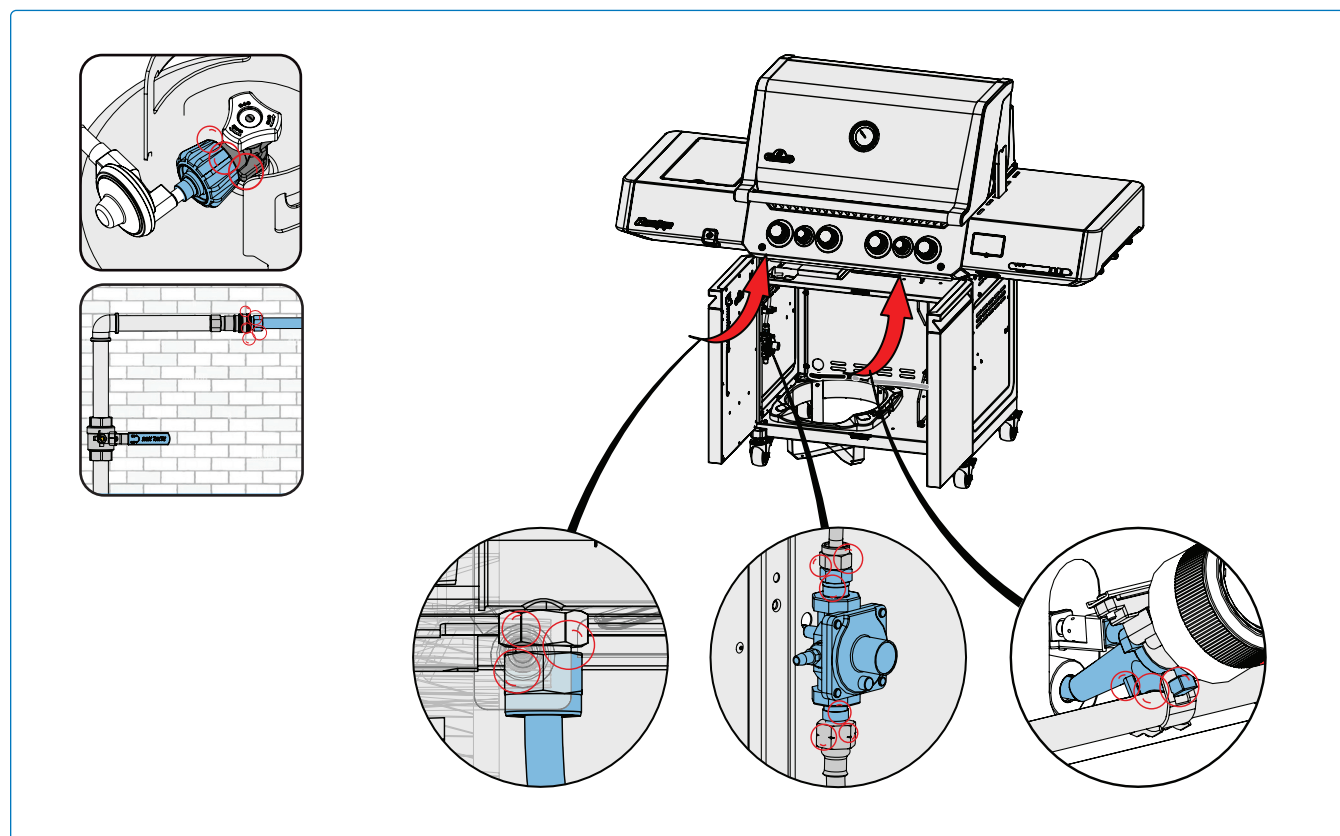
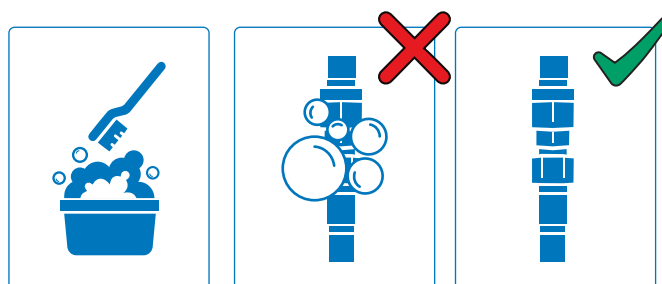

DANGER!

- Never use an open flame to check for gas leaks. Sparks or flames will cause a fire, explosion, damage to property, serious physical injury, or death.
- Only use the pressure regulator and hose assembly supplied with the grill, or one in conformity with local codes.

Operation

Lighting Your Grill

Is it the very first time? Perform a Burn-off

Remove warming rack and run the main burners on high for 30 minutes. It is normal for the grill to emit an odor the first time it is lit. This odor is caused by the “burn-off” of internal paints and lubricants used in the manufacturing process and will not occur again.

WARNING!

- Do not operate the rear or side burner while performing a Burn-Off.

Main Burner Lighting

1. Open grill lid.
2. Push and slowly turn any main burner knob counter clockwise to HIGH position until pilot lights. Continue to push down on the control knob until the burner lights and then release.
3. If the pilot does not light – immediately turn the control knob clockwise to the OFF position. Repeat step 2.
4. If the pilot and burner will not light in 5 seconds – turn the control knob clockwise to the OFF position. Wait 5 minutes for gas to dissipate. Repeat steps 2 and 3 (**Fig. 6**), or see "Alternative Ignition Instructions" (**Fig. 8**).

WARNING!

- Do not use the rear burner while operating the main burner.

Rear Burner Lighting (if equipped)

1. Open grill lid.
2. Remove warming rack.
3. Push and slowly turn rear burner knob counter clockwise to HIGH position.
4. Press and hold igniter button until the burner lights.
5. If the burner will not light – turn burner control knob clockwise to the OFF position. Wait 5 minutes. Repeat steps 3 and 4 (**Fig. 6**), or see "Alternative Ignition Instructions" (**Fig. 8**).

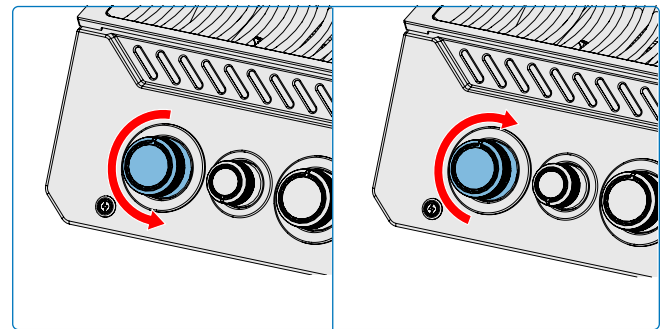
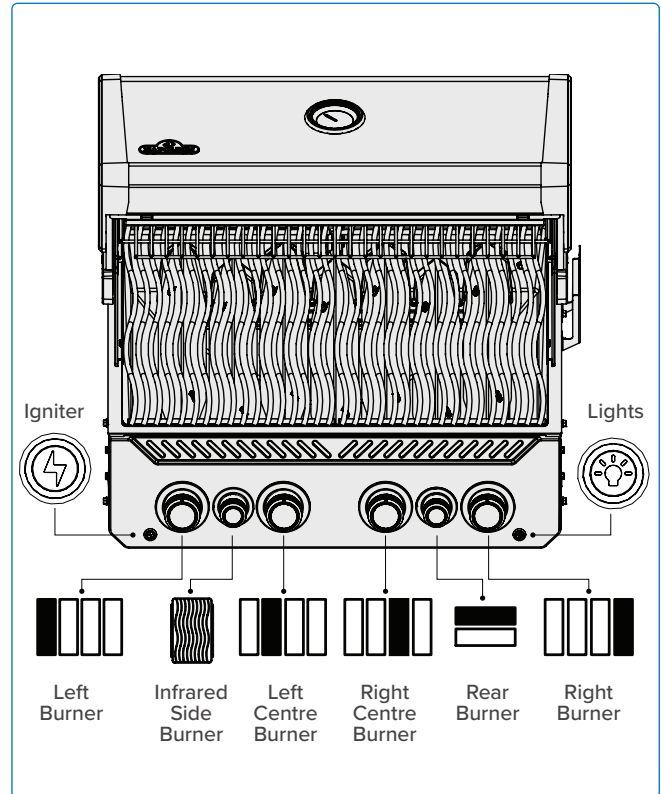

Fig. 6

Side Burner Lighting (if equipped)

1. Open burner cover.
2. Push and slowly turn side burner knob counter clockwise to HIGH position.
3. Press and hold igniter button until the burner lights.
4. If the burner will not ignite within 5 seconds – turn burner control knob clockwise to the OFF position. Wait 5 minutes. Repeat steps 2 and 3 (**Fig. 7**), or see "Alternative Ignition Instructions"

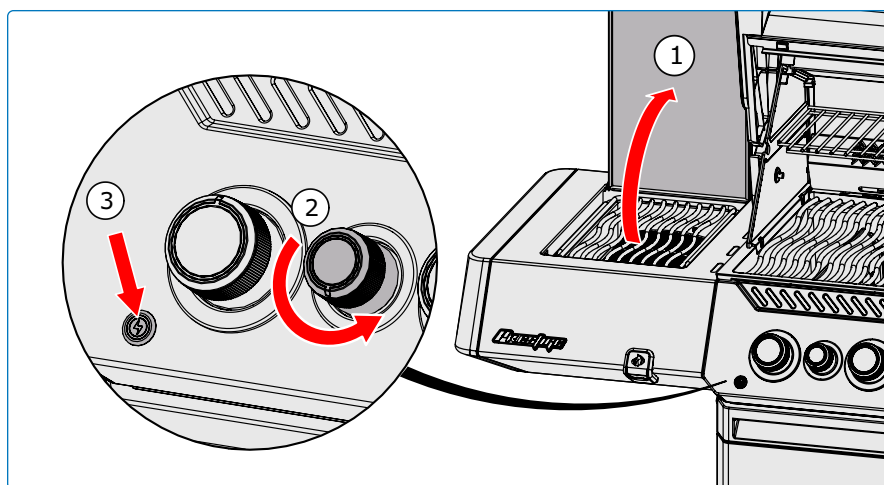

Fig. 7

Alternative Ignition Instructions

1. Open grill lid.
2. Light a long-reach match or butane lighter and position it close to the burner ports.
3. Turn the corresponding burner knob counter clockwise to the HIGH position until it lights. (**Fig. 8**).

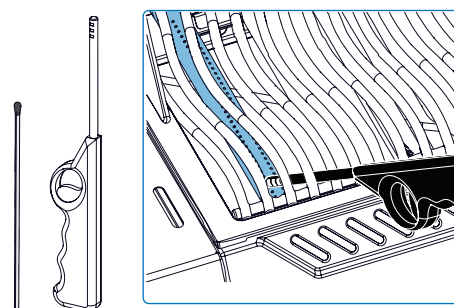
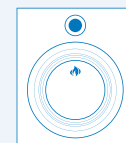

Fig. 8



WARNING!

- Ensure all burner controls are in the OFF position before slowly turning on gas supply valve.
- Follow the lighting instructions carefully.
- Make sure the lid of the grill is OPEN while igniting.
- Do not adjust the cooking grids while the grill is hot, or operating.
- Regularly clean grease out of the entire unit, including the grease tray and the sear plates, to avoid build-up and grease fires.



Grilling Instructions

Main Burner Use

- Preheat the grill before searing food by operating all main burners on high with the lid closed for approximately 10 minutes.
- Food cooked for only a short time such as fish and vegetables can be grilled with the lid open.
- Grilling with the lid closed ensures higher and consistent temperatures that cook meat more evenly and can reduce cooking times.
- The cooking grids can be oiled before preheating to reduce sticking when grilling lean meat such as chicken breast, or pork.
- Food that takes longer than 30 minutes such as roasts can be cooked indirectly with the burner lit opposite the food. See Indirect Grilling.
- Trim excess fat off meat to prevent flare-ups, or reduce the temperature of the grill.
- Flare ups – move food away from the flames and reduce the heat. Leave the lid open.

Direct Grilling

This method is often used for searing, or food cooked for only a short time such as hamburgers, steaks, chicken, or vegetables.

Place food on the cooking grids directly over the heat. Sear meat first to trap-in the juices and flavor. Lower the grill temperature to finish cooking to your preference.

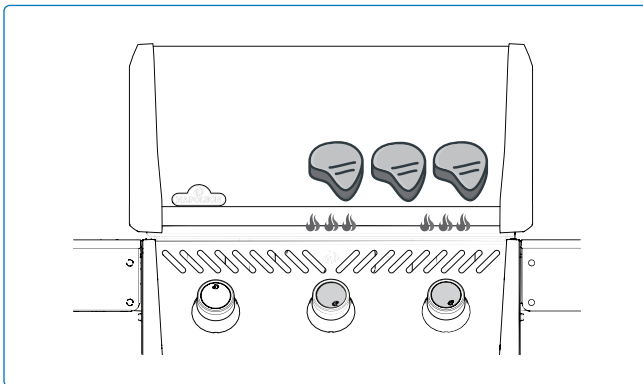

Indirect Grilling

This method uses lower temperatures and circulates heat around the food cooking it slowly and evenly. Use this method to cook larger cuts of meat, or food prone to flare-ups such as roast, chicken, or turkey.

Turn one or more burners on and place food on the cooking grid where there is no flame, or burner on.

Grilling at a lower temperature and slower cooking time results in more tender meats.

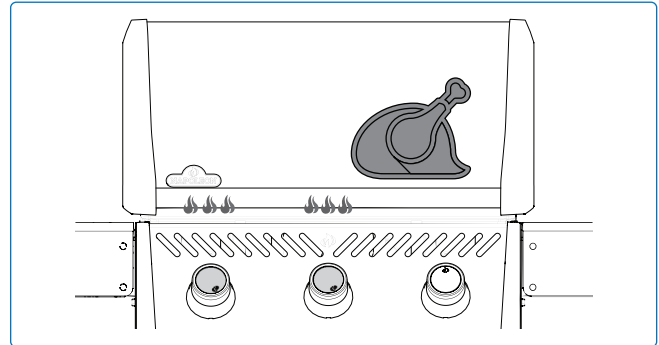

Monitoring Grill Temperatures

Some models are equipped with two temperature indicators. A lid-mounted gauge indicates the air temperature within the cooking enclosure and is the preferred reference for the indirect cooking method. A base-mounted sensor measures the temperature at the cooking grids and is the preferred reference for the direct cooking method. While optimized airflow throughout the cooking enclosure maximizes heating rates and temperature uniformity, several factors influence temperature readings, including:

Food and Accessories Placement

- Large food items or cookware accessories, such as griddles and planchas, can trap heat over top of the cooking grid temperature sensor. This may lead to elevated sensor readings while also reducing lid temperature gauge readings as heat is directed elsewhere.

Burners in Operation

- Temperature readings are affected by burner settings, as well as the base-mounted sensor's proximity to grill burners which are in operation.



DANGER!

- Never grill food directly on the flame side burner. It is designed for use with pots and pans only.
- Do not close side burner lid while it is operating or hot.
- Do not deep fry food on the side burner. Cooking with oil can be dangerous.
- Regularly clean grease out of the entire unit, including the grease tray and the sear plates, to avoid build-up and grease fires.



GRILLING PRO TIP!

Use a thermometer to check the internal temperature of meat to ensure it is cooked perfectly.

Time Elapsed

- The temperature indicators have different response times and may initially display varied readings as the appliance heats up. However, similar readings will be achieved once internal temperatures have stabilized.

For best results, utilize the temperature sensor feature along with the lid temperature gauge to fully compare the cooking environment against your target range. Allow time for temperatures to stabilize and adjust burner control settings accordingly.

Infrared Side Burner

To operate, follow the “**Side Burner Lighting**” instructions. The infrared heat provides an even cooking area for searing food when it’s set to high. Some side burner models have a height-adjustable cooking grid. The maximum recommended pot or pan diameter is 10” (25 cm).

Grilling at Night (if applicable)

Illuminate the control knobs by pushing the light bulb icon on the control panel. When a burner is operating, the corresponding knob will glow red, while the rest will remain blue.

Wind Guard

Keep your grill cooking smoothly in windy conditions up to 11 km/h (6.8 mph). Designed to attach easily to your grill, this guard acts like a shield against gusts of wind, helping to maintain consistent heat for evenly cooked meals. Just adjust it to fit your grill, and you’re ready to grill with confidence, no matter the weather. The guard can be folded and tucked away under the side burner lid for easy storage when the side burner is not in use.

NOTE: The wind guard must be installed when using the side burner. This enhances safety and reduces cooking times.

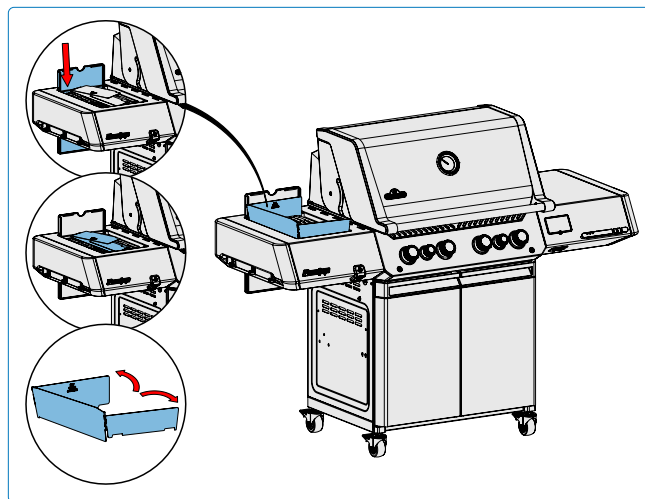

WARNING!

- Do not leave food unattended on any lit burners.
- Keep the lid open if main infrared burner is set on high to prevent accidentally burning food.



GRILLING PRO TIP!

Turn the grill perpendicular to the wind direction to minimize its effects.

How to Use the Rotisserie

Assembling Your Rotisserie Kit (if equipped)

Note: Remove the warming rack prior to using the rear burner and spit rod. Extreme heat will damage the warming rack. Install the rotisserie motor on the side of the grill using the mounting bracket(s). Some models have pre-mounted brackets.

1. Once the bracket has been fastened to the grill, slide the rotisserie motor onto the bracket.
2. Slide the first rotisserie fork just past the middle of the spit rod and tighten into place. Thread the meat onto the spit rod and push the meat into the fork. Slide the second rotisserie fork on the opposite end of the spit rod and push the fork into the meat until secure. Tighten the fork into place.
3. Carefully insert the pointed end of the spit rod into the rotisserie motor and set the opposite end across the hangers. The heavy side of the meat will naturally hang down to balance the load.
4. Slide the stop bushing onto the spit rod until it is past the inside of the hood. This will secure the side to side movement of the spit rod.
5. Tighten the stop bushing and spit rod handle. Place a metal dish under the meat to collect the drippings.



IMPORTANT! Always wear gloves when handling components of the grill.

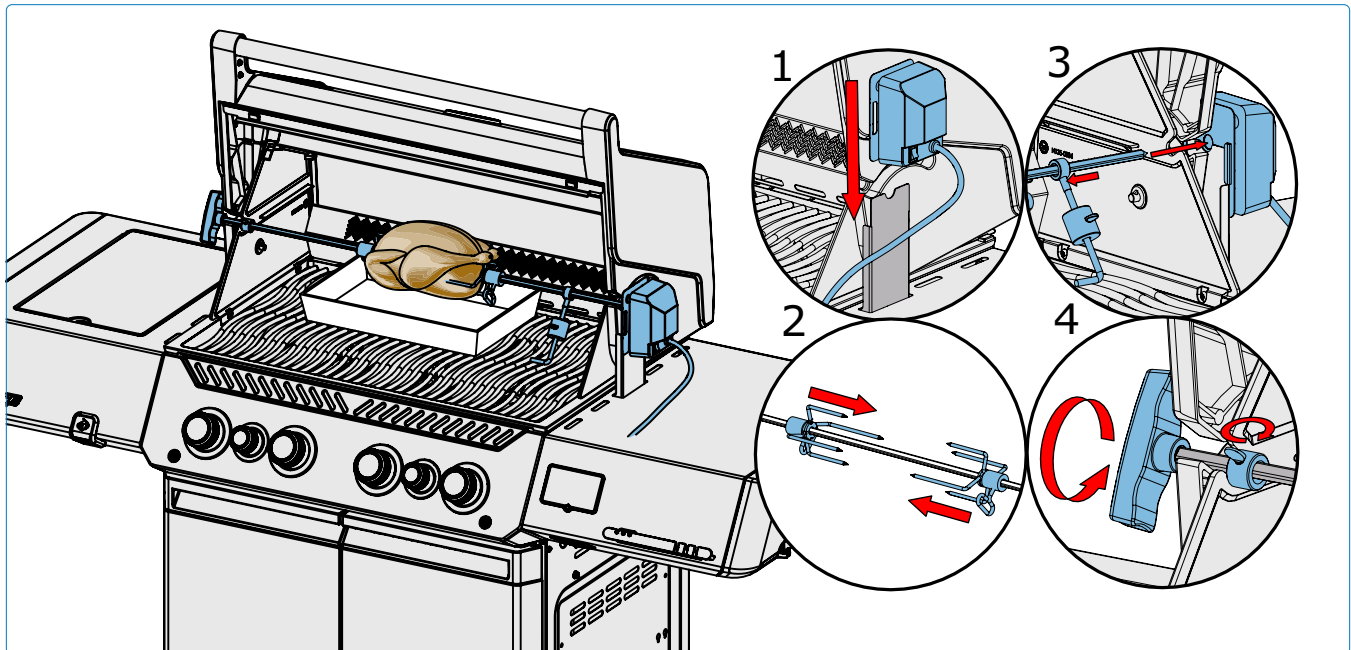

Tips about using the Rotisserie:

- Operate the rear burner on high until the meat browns. Reduce heat. Keep lid closed.
- Use a thermometer to check the internal temperature of the meat.
- Roasts and poultry should brown on the outside and stay tender on the inside.
- Use drippings to baste and make gravy.
- A 3-pound chicken takes approximately 1 ½ hours on medium to high.
- Be mindful of your rotisserie motor capacity (15lb.). Never overload your equipment.
- Be sure to always set an evenly balanced load on your rotisserie.

How to cook multiple chickens

Tie or skewer wings to the body of the chickens.

1. Slide rotisserie fork onto spit rod.
2. Thread first chicken onto spit rod until it is held into place by the rotisserie fork. Tighten.
3. Thread next 2 chickens onto spit rod so all the chickens are close together.
4. Slide second rotisserie fork onto spit rod and push into chicken until all 3 chickens are squeezed together tightly. Tighten.

The Grilling Experience Checklist

Be sure to have read the owner's manual and all the safety instructions.

Refer to this list every time you grill

- Clean grease tray**
Always ensure you clean the grease tray prior to grilling to avoid fires and flare-ups.
 - Check the hose**
Ensure the grill is off and cool. Check the hose for evidence of excessive abrasions, or cuts. Have the hose replaced before use if the hose is damaged.
 - Preheat and clean grids**
Coat the grids with vegetable shortening and preheat your grill to burn off excess residue and prevent sticking. Clean cast iron grids with a brass wire brush and stainless steel grids with a stainless brush. See "**Cleaning Instructions**".
 - Prep area**
Make sure everything you need while grilling such as your utensils, seasonings, sauces, and dishes are within your reach. Don't leave your food unattended, or it could burn.
 - Flip once and do not peek**
Try not to open the lid and peek too much, or heat will escape and throw your temperature and cooking times off. Flip your food only once, especially steak and chicken.
 - Leave space**
Leave some space on the grill and between food, so you have room to move food around if you need to.
 - Use a thermometer**
Use a thermometer to ensure food is cooked thoroughly. Follow the appropriate temperatures guidelines for all types of meat, especially poultry.
-  **NOTE:** Stainless steel cooking grids are corrosion resistant and require less maintenance than cast iron grids.



GRILLING PRO TIP!

Discover inspiring recipes and grilling techniques in Napoleon®'s cookbooks or visit www.napoleon.com



GRILLING PRO TIP!

Always preheat the grill before cooking to burn off leftover residue and prevent food from sticking to the grate.



OIL AND FAT SUGGESTION!

Grapeseed Oil
Sunflower Oil
Soybean Oil
Extra Virgin Olive Oil
Canola Oil

If not available, select an oil or fat that has a high smoke point. Do not use salted fats like butter or margarine.



CAUTION!

How to Season Cast Iron Cooking Grids (if equipped)

This procedure **MUST** be done prior to first use and repeated every 3-4 uses to keep grids looking new.

1. Remove cast iron grids from the grill.
2. Wash grids with warm soapy water and soft cloth. Pat dry and allow grids to completely dry.
3. Apply fat/oil evenly using a silicone brush on both sides.
4. Preheat appliance to 350 °F - 400 °F (176 °C - 204 °C).
5. Install cooking grids and cook for 30 minutes.
6. Apply a second even coat of fat/oil on cooking grids, and keep cooking for 30 more minutes.
7. Grids are now seasoned.



NOTE: If rust has formed on the cast iron grids, remove the rust with scouring pad or brass brush and repeat the seasoning process.

Quick Start Instructions

1

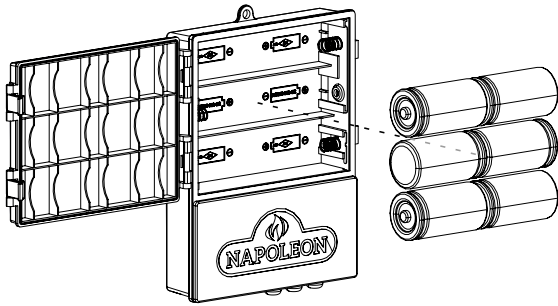

Insert the batteries into the compartment.

2

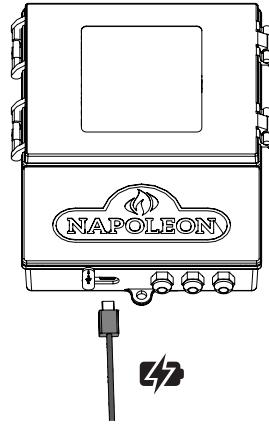

Alternatively, the device can be powered using a direct supply through the USB Type C port. To do this, use a 5V 1A adapter. It is recommended to remove the batteries if using direct supply to prevent corrosion and prolong battery life.

3

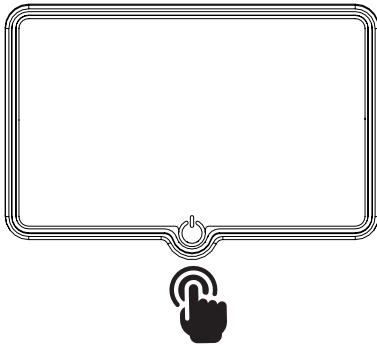

Ensure your device is turned on.

4

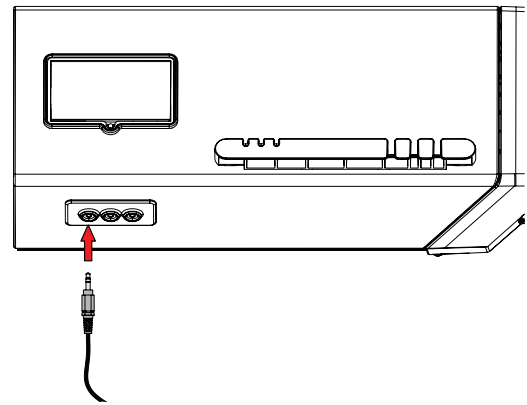

Remove the protective plastic and plug one or more probes into your appliance.

5

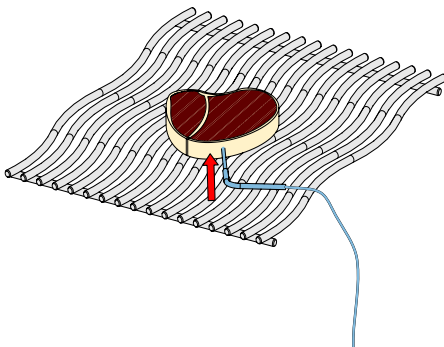

When using meat probes, ensure that the tip of the probe is inserted into the thickest section of the food, avoiding bones or fat.

6

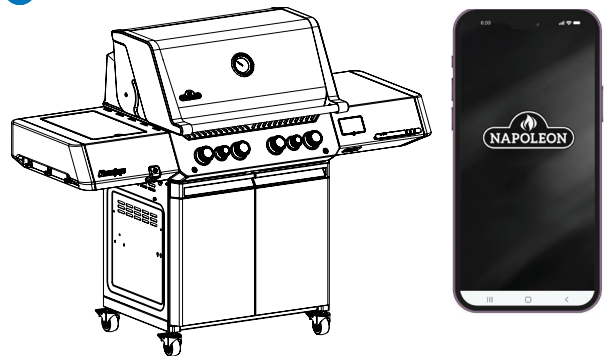

Follow the instructions in the next section to connect to the Napoleon® Home App. Enjoy your meal!

Napoleon Connectivity

NAPOLEON® HOME APP

HOW DOES IT WORK?

Access your appliance remotely by downloading the **Napoleon® Home App** from the App Store or Google Play.

In order to access the app, you will be required to create an account by following the instructions listed within the app (see below for details).



By pairing your appliance to the **Napoleon® Home App** via Wi-Fi, you gain control to all modes and functions of the appliance.

All notifications and alarms are sent through the app to keep you connected with ease.

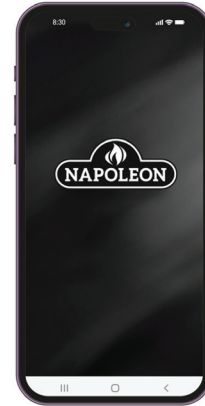

Scan this QR code for direct access to the **Napoleon® Home App** website.



LET'S GET STARTED

1 Register

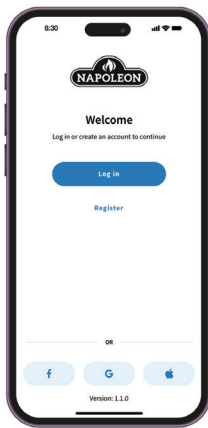

Register an account with the **Napoleon® Home App** OR sign-in using your Facebook, Google, or Apple account information.

2 Create

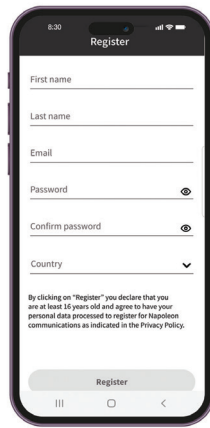

Enter user information and create a password for the account. Select the country in which the appliance is located.

3 Almost there



The information entered in Step 3 will be registered to the **Napoleon® Home App** and a confirmation will be sent to the email provided.

4 Confirm

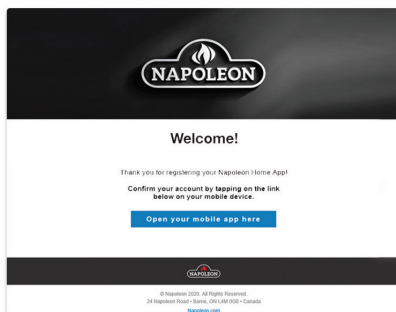

Open email inbox and select the confirmation link. **Note:** The confirmation link must be opened on the device that the Napoleon® Home App is installed on.

5 Re-confirm



If no email is found, click "Re-Send Confirmation Link" and check junk folder.

ADDING A DEVICE

6 Power On

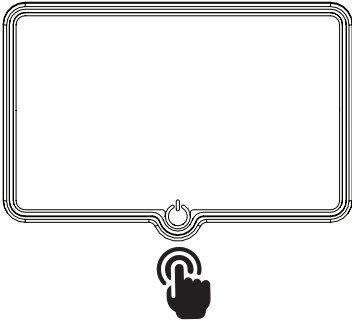

Ensure your device is turned on.
To finalize initial pairing with your smart device, press down on your display for 10 seconds until it restarts.

7 Add Device

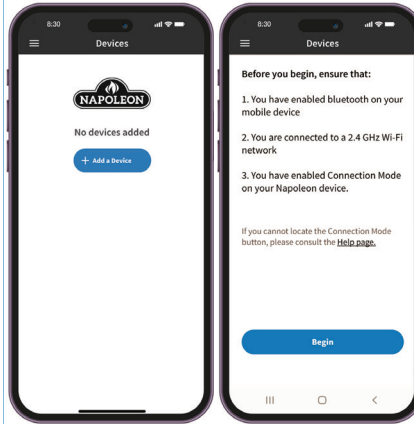

Select "Add Device" and accept the permissions.

8 Search

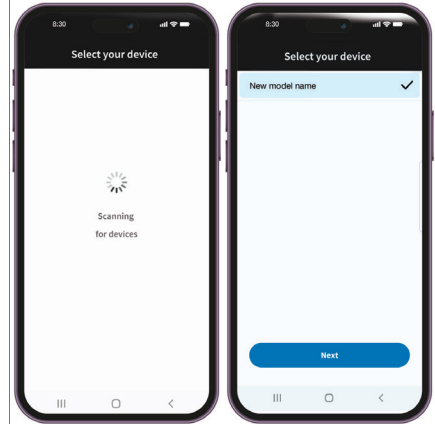

Search for devices and select the device from the list.

9 Network Connection

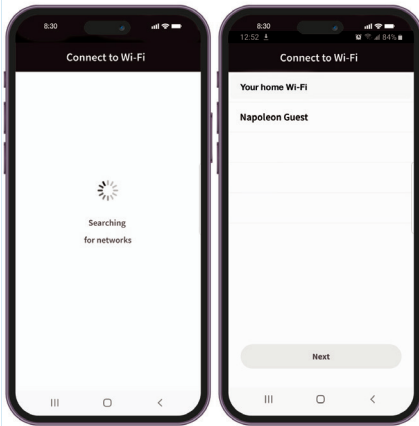

Select the Wi-Fi network and enter your credentials.

10 Add Nickname



Enter a custom name for your device, or proceed with default name provided.

11 Success



You are now **connected**.

ACCU-PROBE® Cook Assist

Confidently tend to the grill and your guests while using the integrated ACCU-PROBE® technology. Monitor internal grill temperature. Easily program your food type, target temperature, and cooking time using your smart device with the Napoleon® Home App.

You will receive notifications on your device when your food is cooked to perfection. ACCU-PROBE® supports both Wi-Fi and Bluetooth® connectivity. If your default Wi-Fi is not available, the Bluetooth® function allows you to connect to ACCU-PROBE® with ease. The device must be initially provisioned using Wi-Fi, then only Bluetooth® will be available.

See "Quick Start Instructions" and "Napoleon® Home App" sections for more information on getting connected. Download the Napoleon® Home App and enjoy smart cooking.

Any use of such marks and logos as indicated are owned by the respective owners and any such use by Wolf Steel Ltd. is under license: Bluetooth® by Bluetooth SIG, Inc. Other trademarks and trade names are those of the respective owners: Android™ and Google Play™ are trademarks of Google Inc.; Apple, iPhone®, and the Apple App Store is a trademark of Apple Inc.; iOS is a trademark or registered trademark of Cisco Inc.

Compatible Devices

The Napoleon® Home App is designed to work with a wide range of Android and iOS devices. Device compatibility is not guaranteed due to numerous different models and manufacturing standards.

Display Overview

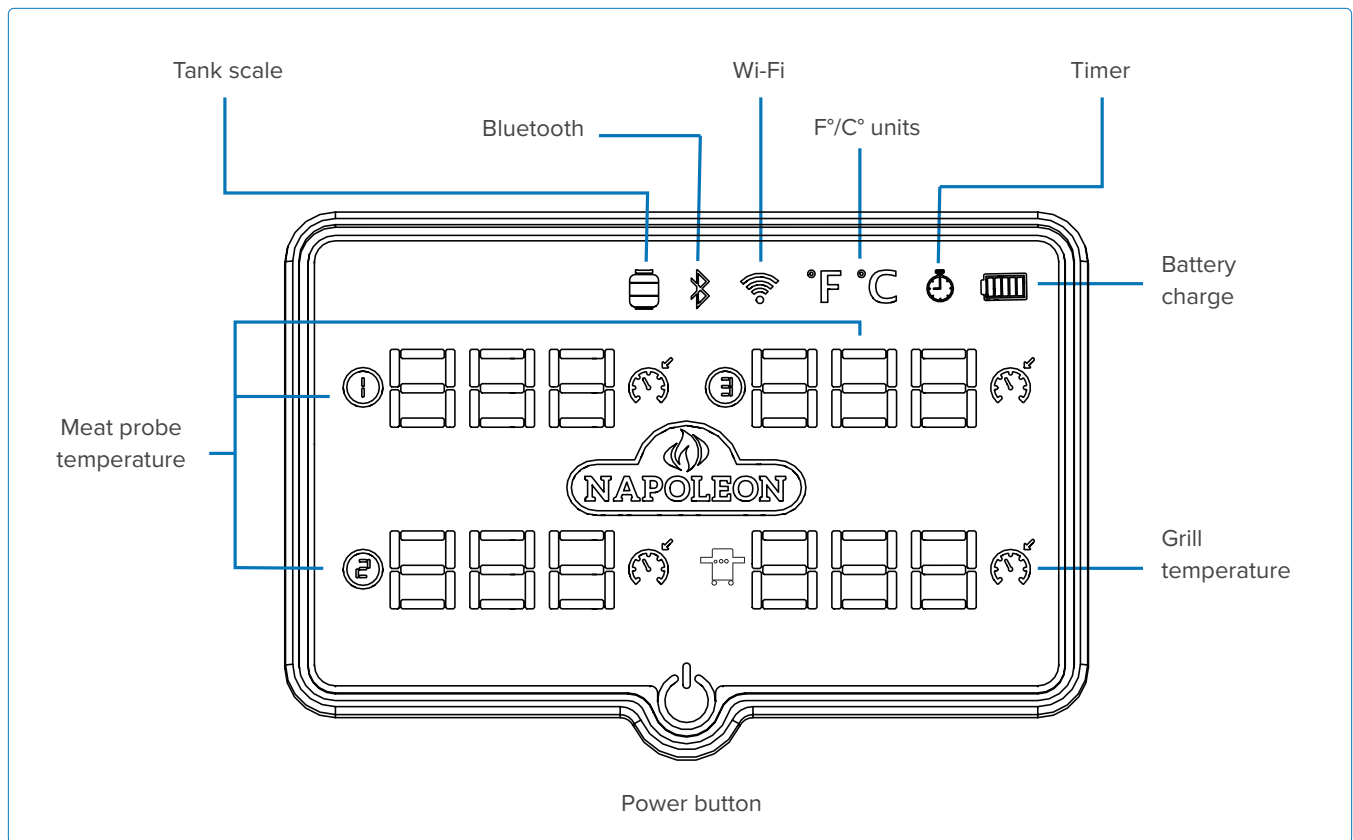

Display Operation

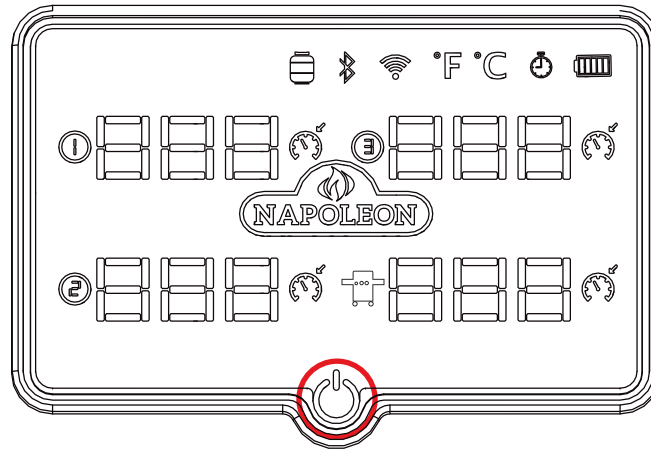

Function	Action	Duration	Description
Pairing Mode	Press and hold	10 seconds	When the system restarts, the Napoleon® logo will appear. The Wi-Fi and Bluetooth® icons will flash, indicating that the device is in pairing (Access Point mode). You will need to provision the device again using the Napoleon® Home App. This process should be completed when the display is active. If the display is off or in display timeout, continue to press and hold the button until Access Point Mode is reached.
Display On/Off	Press and hold	3 seconds	The Napoleon® logo will appear, accompanied by an audible alert. The display will cycle on or off, depending on its current status.
Wake-up Display (On Battery Power Only)	Single tap	N/A	After awakening, the display will seamlessly return to its previous state.
Temperature Unit Change	Single tap	N/A	Toggle between Celsius and Fahrenheit.

In Winter Conditions

For the best experience in winter conditions, use the control panel button to toggle the display on or off. This allows for functionality without the need to remove gloves. Simply long-press the control panel button for more than 3 seconds.

NOTE: The display turns off after 5 minutes of inactivity, returning to default brightness when prompted by user action. If any activity occurs during this time, the 5-minute period resets.

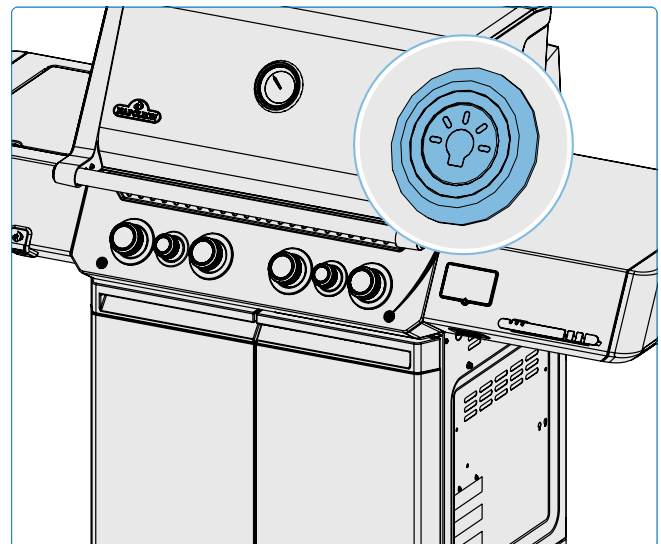

System Monitoring

Safety Glow

Illuminate the control knobs by pushing the light bulb icon on the control panel. When a burner is operating, the corresponding knob will glow red, while the rest will remain blue. In order to conserve battery life, the knobs glowing blue will turn off after 1 hour by default, while the rest will remain red. The shutoff time of 1 hour for battery powered operation can be adjusted within the app. When using a USB power source, the shutoff timer for the lights will be cancelled.

Low Battery

Monitor the battery level status through the app and display. When the system draws power from a battery source, flashing knobs indicate low battery. The system transmits an alert to your device and will shut down once the battery is nearly depleted. Replace the batteries as necessary. The following indicators represent the approximate levels of charge remaining in the batteries:

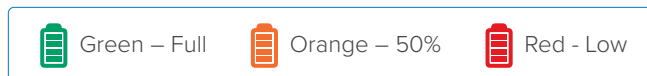

Temperature Alerts

The system can provide audible alerts when target temperatures have been reached. The display will indicate which probes have a target temperature set.

Timer Alerts

The display will indicate when a timer has been set. The system can provide audible alerts when a timer has ended.

Propane Tank Scale

The system can continuously monitor the propane remaining in the tank and provide the status at a quick glance.

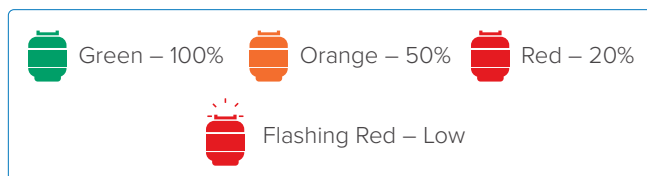

Zero the Scale

Before calibrating:

- Remove the empty tank from the scale. Press the designated button to initiate zero tare.
- Wait 20 seconds for the taring process.
- Place the new tank on the scale after zero tare completion.

Select the Tank

- Launch the Napoleon® Home App.
- Navigate to the tank scale section.

Select Tank and Region:

- Select "New Tank Scale."
- Choose your region (North America, Europe or Custom).
- For North America, default tank weights are selected.
- For Europe, select from the list of available tanks specifications.

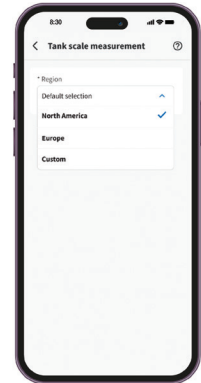

Custom Tank (Optional):

- If you choose custom tank, input the empty tank weight and its full weight. This ensures precise measurements.
 - » Empty Tank Weight (lbs/kg): Enter the weight of the empty tank.
 - » Full Tank Weight (lbs/kg): Enter the weight of the full tank.
- Ensure accurate values before proceeding with placing tank in the holder.

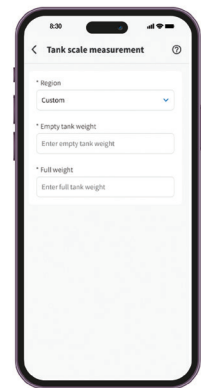

 **NOTE:** It may take about 1 minute to get the data updated to the app.

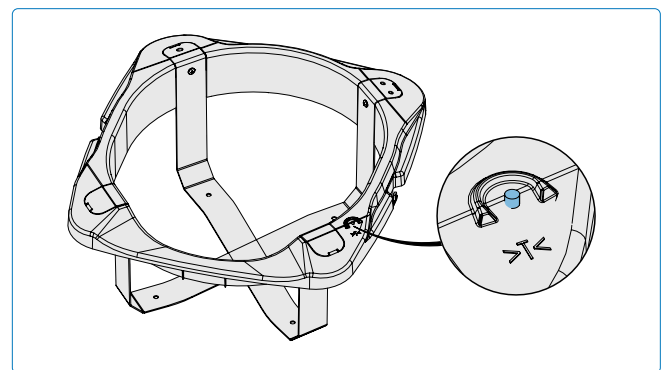

Safeguards

- Avoid high humidity or extreme temperatures.
- Avoid long exposure to direct sunlight or strong ultraviolet light.
- Do not disassemble or try to repair the unit on your own.
- Do not expose the unit or its accessories to flammable liquids, gases, or other explosives.
- Probes can operate from -4 ° F (-20 ° C) to 572 ° F (300 ° C).
- Probe cords can operate from -4 ° F (-20 ° C) to 716 ° F (380 ° C).
- **IMPORTANT:** Do not allow the probes to be directly exposed to flames or temperatures exceeding 572 ° F (300 ° C).
- For accurate readings, insert the probes into the center of meat, ideally before it is placed on the grill.
- **IMPORTANT:** Point the tips of the probes downward but do not allow the tips to touch the cooking grids. Also try to ensure that probes do not touch the body of the grill.
- Place meat on the side of the grill closest to the thermometer.
- Position the cord at a high exit point so the cord stays sufficiently above the cooking grids when the lid is closed.
- Alternatively, probe handles may be positioned under the lid seal. Ensure the sides of the grill do not exceed the highest probe operating temperature.
- When using more than one probe, colored probe rings can help identify the number of each probe. Place each ring around the probe tip and push until it reaches the base holder.

Clearance

- Check that the cooking area does not exceed the maximum temperature and cords are not kinked or frayed by closed doors or lids.
- First check the cord clearance at ambient temperature with the lid closed. Examine the cord for any severe kinking or bending. Then turn the grill ON and check for hot spots where the cord may make surface contact.

Storage



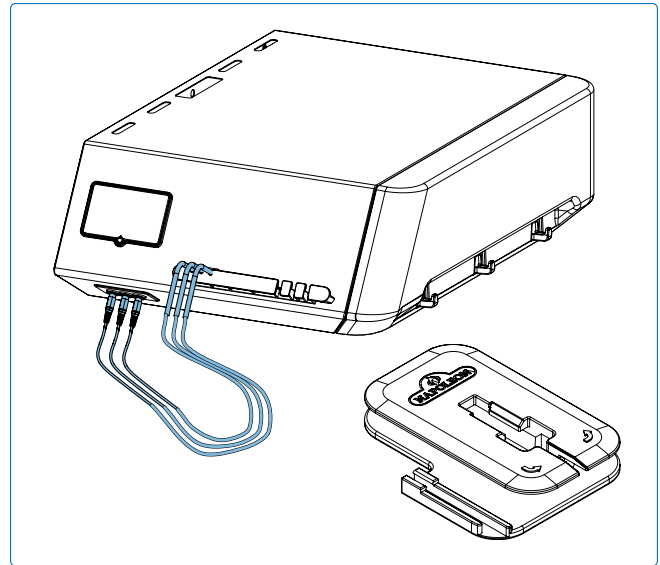



- Use the probe storage provisions on the side shelf when preparing to cook. Unplug the probes and bring them indoors when not in use to protect them from the elements.



WARNING!

- After cooking, do not return the probes to the holder until they cool off.

Infrared Grilling Guide

Food	Control Knob Setting	Cooking Time	Suggestions
 Steak 1 inch (2.54 cm) thick.	HIGH 2 minutes each side.	Rare – 4 minutes	Ask for marbled fat in cut. Fat is a natural tenderizer and keeps meat juicy.
	HIGH to MEDIUM High heat 2 minutes each side then turn to medium heat.	Medium – 6 minutes	
		Well Done – 8 minutes	
 Hamburger ½ inch (1.27 cm) thick	HIGH 2 minutes each side.	Rare – 4 minutes	Keep patties all the same thickness for equal cooking times. Patties 1 inch thick or more should be grilled using indirect heat.
	HIGH 2 ½ minutes each side.	Medium – 5 minutes	
	HIGH 3 minutes each side.	Well Done – 6 minutes	
 Chicken	HIGH, MEDIUM, LOW 2 minutes each side then medium-low to low heat.	20 – 25 minutes	Slice joint connecting the thigh and leg ¾ through for the meat to lie flat on the burner and cook evenly.
 Pork Chops	MEDIUM	6 minutes each side	Choose thick cuts for more tender meat. Trim off excess fat.
 Spare Ribs	HIGH to LOW High for 5 minutes then low until finished.	20 minutes each side turning often	Choose lean meaty ribs. Grill until meat pulls easily from the bone.
 Lamb Chops	HIGH to MEDIUM High for 5 minutes then Medium until finished.	15 minutes each side	Choose thick cuts for more tender meat. Trim off excess fat.
 Hot dogs	MEDIUM to LOW	4 – 6 minutes	Select larger wieners and slit lengthwise before grilling.

Cleaning Instructions

First Time Use

1. Wash grids by hand with water and mild dish soap to remove any residue from the manufacturing process. DO NOT wash in a dishwasher.
2. Rinse thoroughly with hot water and dry completely with a soft cloth to prevent moisture from entering the cast iron.

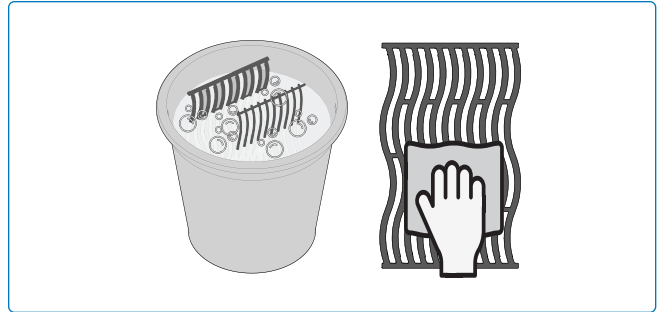

Cast Iron Grids

- Season your grids every 3-4 uses to add a protective coating to prevent corrosion See Grilling Tips – **How to Season your Cast Iron Cooking Grids.**

Stainless Steel Grids

- Stainless steel cooking grids can be cleaned by preheating the grill with every use and using a wire brush to remove residue.
- Stainless steel grids will permanently discolor from regular use because of high temperatures when grilling.

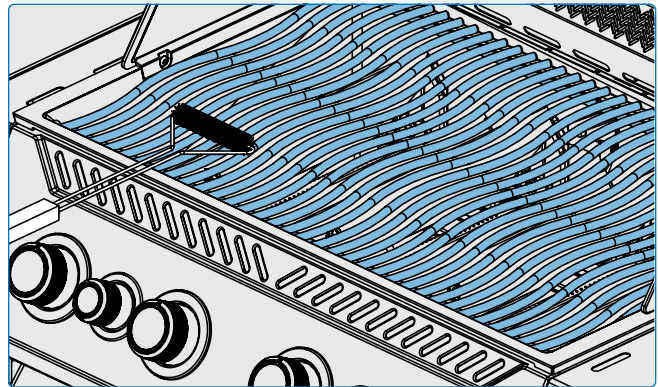

Infrared Side Burner

- Most drippings and food particles that fall on the infrared burner surface incinerates immediately because of the high intensity heat.
- Do not clean the ceramic tile with a wire brush.
- Do not use water or other liquids to clean the burner. An immediate change in temperature will cause cracking of the ceramic tile.
- Every 3-4 uses, light burner and operate on high for 5-10 minutes to remove any left-over residue.

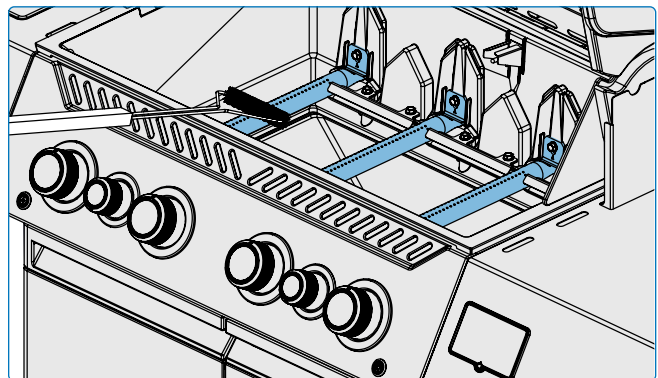

DANGER!

- Always wear protective gloves and safety glasses when cleaning your grill.
- Accumulated grease is a fire hazard.
- Cleaning should only be done when the grill is cool to avoid the possibility of burns.

Inside of the Grill

1. Remove the cooking grids.
2. Clean the inside of the grill at least every 3 months under moderate use, or more frequently as required.
3. Use a brass wire brush to clean loose debris from the sides and underneath the lid.
4. Scrape the sear plates with a putty knife or scraper. Use a wire brush to remove the ash.
5. Remove the sear plates and brush debris from the burners with a wire brush.
6. Sweep debris from inside the grill into the drip pan.

Aluminum Castings

Clean with warm soapy water at least once per season. Aluminum doesn't rust, but high temperatures and weathering can cause oxidization on the surface of the castings that look like white spots.

See "**Maintenance Instructions**" for more information on how to prevent oxidized aluminum.

Drip Pan

Every grill head, side burner and drop-in burner have a corresponding drip pan. It is easily accessible through doors or openings.

- Grease and excess drippings collect in the drip pan located beneath the grill and accumulate in the disposable grease tray below the drip pan (if applicable).
- Only use Napoleon approved liners on the drip pan. Never use aluminum foil, sand or any other unapproved material. This can prevent grease from flowing properly.
- Clean frequently to avoid grease build-up – approximately every 4-5 uses.

Cleaning steps:

1. Slide the drip pan from the grill to access the disposable grease tray or to clean the drip pan.
2. Scrape the drip pan out with a putty knife or scraper.
3. Replace the disposable grease tray every 2-4 weeks depending on grill usage (if applicable).
4. See your Napoleon Grill dealer for supplies.

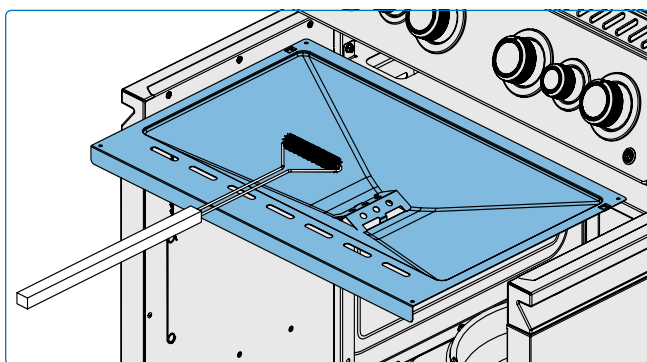
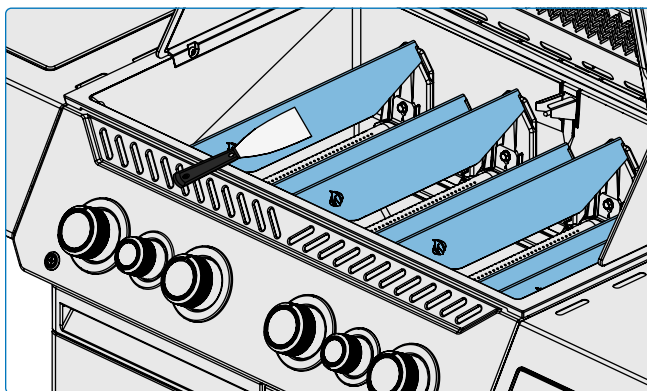
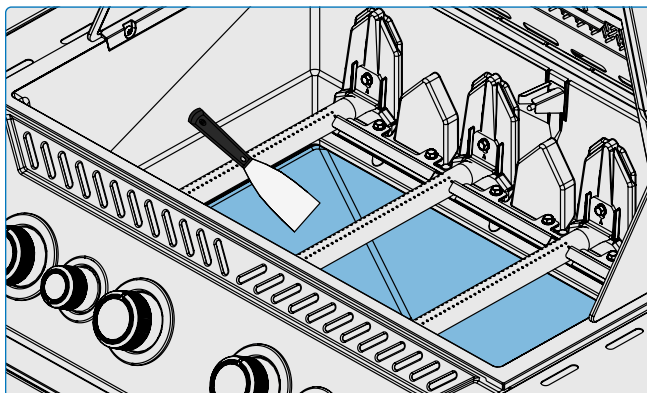
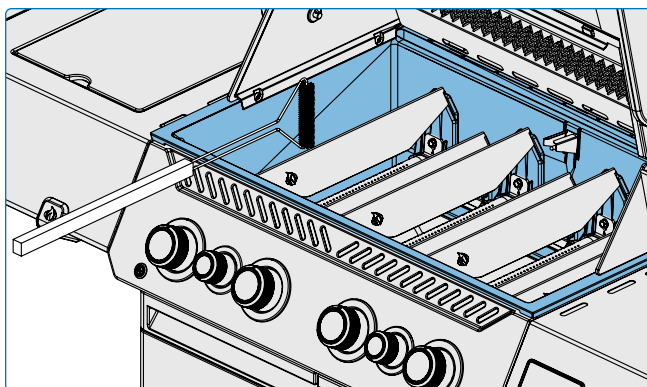

Control Panel

ONLY use warm soapy water. Text is printed directly on the control panel and will gradually rub off if abrasive or stainless steel cleaners are used. Proper cleaning of the control panel whenever it become dirty will ensure the text remains dark and legible.

Outside Grill Surface

Clean the outside of the grill once a month under moderate use, or more frequently as required.

- Only use a non-abrasive cleaner. Abrasive cleaners or steel wool will scratch the finish.
- Always wipe in the direction of the grain.
- Handle porcelain enamel components with care.
- The baked-on enamel finish is glass-like and will chip if struck.

Stainless steel parts discolor over time when heated and will turn a golden or brown hue. This is normal and won't affect the performance of the grill.

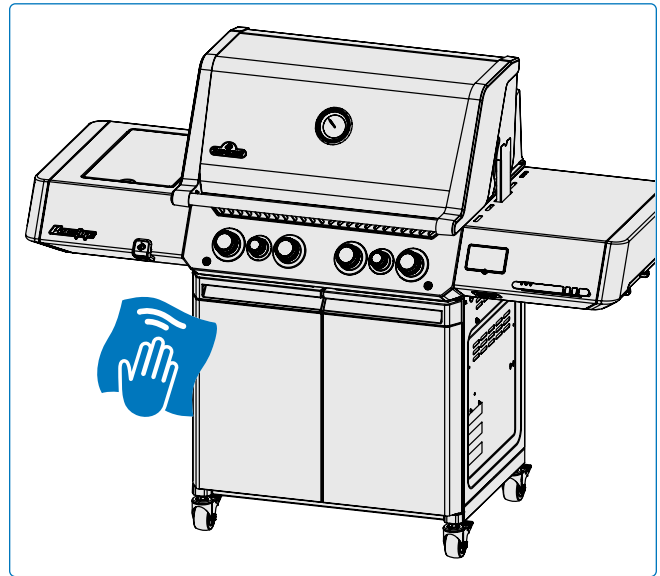

WARNING!

- Barbecue sauce and salt can be corrosive and will cause rapid deterioration of the grill components unless cleaned regularly.
- Ensure all burners are turned off and grill is cool before cleaning. Do not use oven cleaner to clean any part of the grill.
- Do not put cooking grids or any other parts of the grill in a self-cleaning oven to clean.
- Clean the grill in an area where cleaning solution won't harm decks, lawns, or patios.

Insect Screen and Burner Ports

Spiders and insects are attracted to small enclosed spaces.

Napoleon has equipped the burner with an insect screen on the air shutter. This reduces the likelihood of insects building nests inside the burner, but doesn't eliminate the problem.

A nest or web can cause the burner flame to burn a soft yellow or orange and cause a fire or flashback at the air shutter underneath the control panel. Refer to the following steps if this occurs.

1. Remove the screw (s) that attaches the burner to the back wall of the grill. Slide the burner back and upwards to remove. **(Fig.9)**
2. Clean the inside of the burner using a flexible venturi tube brush or, for delicate areas, a soft bristled brush to gently remove debris.
3. Shake loose debris from the burner through the gas inlet.
4. Check the burner ports and valve orifices for blockages: burner ports can close over time

because of cooking debris and corrosion.

5. Use an opened paper clip, or the supplied port maintenance bit to clean burner ports.
6. Drill out blocked ports using the supplied drill bit in a small cordless drill: this can be done with the burner attached to the grill, but it's easier if removed from the grill.
7. Ensure the insect screen is clean, tight, and free of any lint or other debris.
8. Reverse the procedure to reinstall the burner.
9. Ensure the valve enters the burner when installing.
10. Replace sear plate mount and tighten screws to complete re-installation.

NOTE: When drilling the ports do not flex the drill bit as the drill bit will break. This drill bit is for burner ports, NOT for brass orifices that regulate the gas flow to the burner. Do not enlarge the holes.

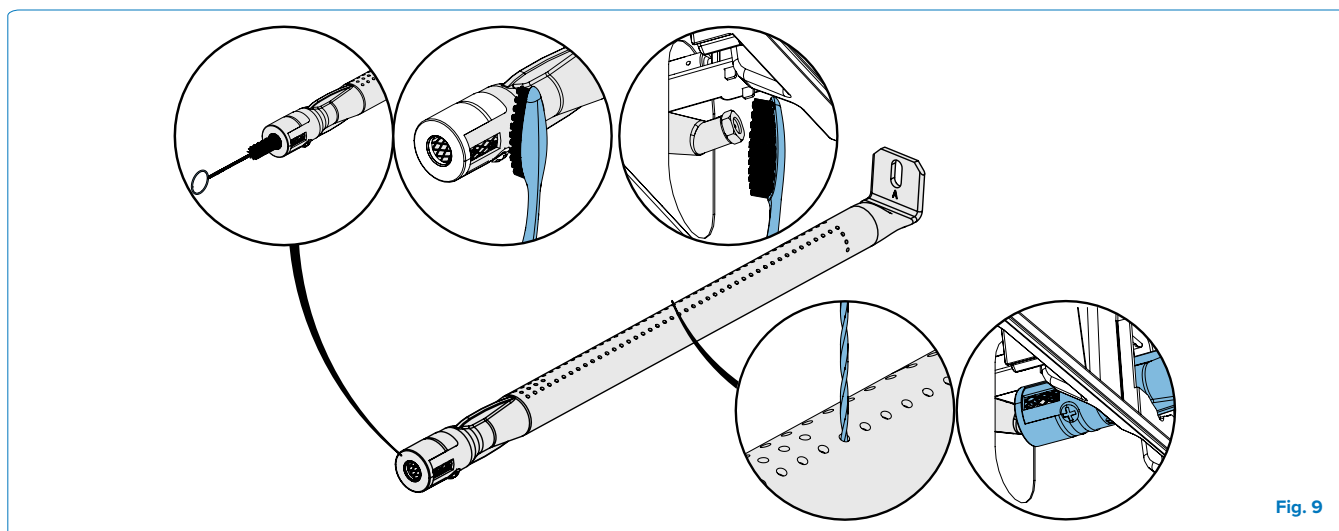

Fig. 9

Temperature Probes

- Clean the probes before using for the first time.
- Hand wash the metal portion of probes and dry thoroughly after each use. Do not wash in a dishwasher.
- Probes are rust-proof and corrosion resistant. Do not use any chemicals or cleaning solutions to clean the probes except mild soap.

NOTE: The probe jacks, probe cables, and display unit are water resistant but should not be left in the rain. The appliance should never be immersed in water.



DANGER!

- It is very important the valve/orifice enters the burner tube when reinstalling the burner after cleaning and before lighting your grill, or a fire or explosion could occur.
- Avoid unprotected contact with hot surfaces.
- Do not use abrasive cleaners or steel wool on any painted, porcelain, or stainless steel parts of your grill because it will scratch the finish.



SAFETY FIRST!

Always wear protective gloves and safety glasses when servicing your grill.

Maintenance Instructions

General Requirements

This grill should be thoroughly inspected and serviced annually by a qualified service person.

- Do not obstruct the flow of ventilation and combustion air.
- Keep the cylinder enclosure ventilation openings located on the side of the cart or enclosure and front and back of the bottom shelf clear from debris.
- Sealed parts must not be manipulated by the user.

Combustion Air Adjustment



IMPORTANT! This must be done by a qualified gas installer.

- The air shutter is factory set and should not require adjusting under normal conditions. Adjustments might be required under extreme field conditions.
- The flames of the air shutter will be dark blue, tipped with light blue and occasionally yellow when adjusted correctly.
- Too little air flow to the burner will produce soot and lazy yellow flames.
- Too much air flow to the burner will cause flames to lift erratically and cause igniting difficulties.

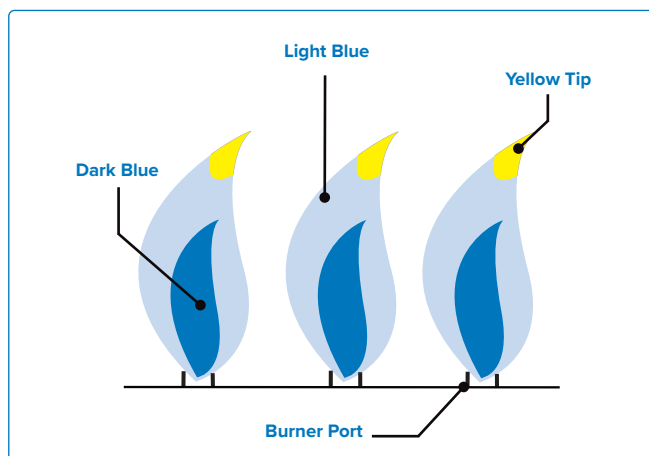

Adjusting the Air Shutter

1. Remove cooking grids and sear plates. Leave lid open.
2. You may have to open the cabinet door or remove the top drawer (if equipped) to access the air shutter screw located at the mouth of the burner.
3. Remove the back cover to access the rear tube burner.
4. Unscrew and remove the main tube burner and adjust to the correct air shutter setting.
5. Loosen air shutter lock screw and open or close air shutter as required.
6. Reinstall the burner ensuring the burner is positioned correctly over the orifice before re-tightening screw.
7. Light the burners on high.
8. Visually inspect burner flames.
9. Turn burners off, tighten locking screws, and replace removed parts when shutters are set correctly.
10. Ensure insect screens are installed.



NOTE: Infrared burners have no air adjustment.



WARNING!

- Keep the grill away from combustible materials, gasoline, and other flammable vapors and liquids.



WE WANT TO HELP!

Contact an authorized
Napoleon® dealer
for recommended
replacement parts.

Stainless In Harsh Environments

Stainless steel oxidizes or stains in the presence of chlorides and sulfides, especially in coastal regions, warm and highly humid areas, and around pools and hot tubs. These stains look like rust, but they can be easily removed or prevented. Wash stainless and chrome surfaces every 3-4 weeks. Clean with warm soapy water.

Burner Maintenance

Extreme heat and a corrosive environment can cause surface corrosion to occur even though the burner is made from heavy wall 304 stainless steel.

Maintenance and Protection of Infrared Burners

Your infrared burners are designed to provide a long service life, but you must be careful to prevent cracking of their ceramic surfaces. Fractures will cause the burners to malfunction.



IMPORTANT! Damage resulting from by failure to follow these instructions is **NOT** covered by your grill warranty.

Clearance Ventilation of Hot Air

- Hot air must have a way to escape the grill for the burners to function properly.
- The burners can become deprived of oxygen if the hot air is not allowed to escape causing them to back-flash. The ceramic can crack if this occurs repeatedly.

Steps to Avoid Damaging Ceramic Surfaces

1. Never douse a flame or control flare-ups with water.
2. Do not allow cold water (rain, sprinkler, hose etc.) to come in contact with hot ceramic burners. An immediate change in temperature will cause cracking of the ceramic tile.
3. A ceramic burner that becomes wet before use will create steam when operated later and produce pressure that will crack the ceramic.
4. Repeated soaking of the ceramic can cause it to swell and expand producing pressure that will make the ceramic crack and crumble.
5. Inspect the ceramic for possible water soaking if you find standing water in the grill. Remove the burner if the ceramic is wet. Turn it upside down to drain the excess water. Bring ceramic indoors to dry thoroughly.
6. Do not allow hard objects to impact the burner. Take care when inserting or removing cooking grids and using accessories.

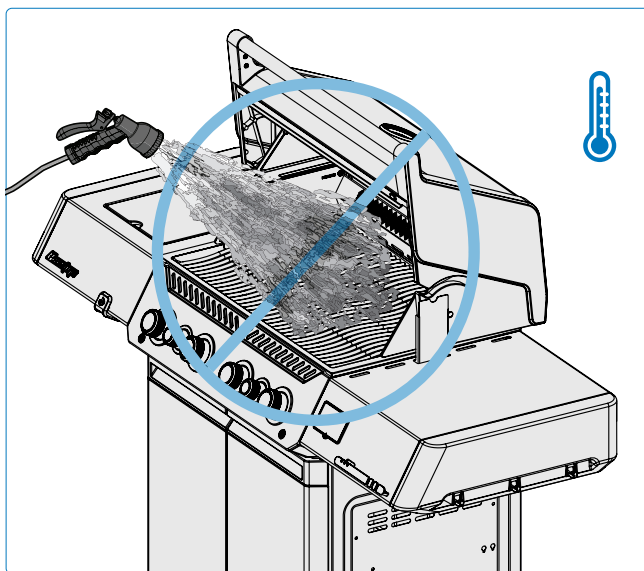

DANGER!

- Turn off gas at the source and disconnect the unit before servicing.
- Maintenance should only be done when the grill is cool to avoid the possibility of burns.
- A leak test must be performed annually and when any component of the gas train is replaced, or when the smell of gas is present.



SAFETY FIRST!

Never cover more than **75%** of any main or side burner cooking surface with any solid metal (e.g. griddles or pans)

Leveling Your Appliance

Adjustable casters assist with leveling the appliance.

1. Engage the wheel brakes on the casters opposite to the one being adjusted.
2. Carefully lift and support the appropriate side of the appliance base to allow the caster to rotate freely.
3. Loosen the retaining nut at the top of the caster stem.
4. Use a wrench to rotate the bottom caster stem nut counterclockwise to lower that corner of the appliance, or clockwise to raise it.
5. Once the desired height is reached, tighten the retaining nut against the appliance base to secure the caster in its new position. Repeat this procedure on the remaining casters until the grill is level and fully supported on each corner.

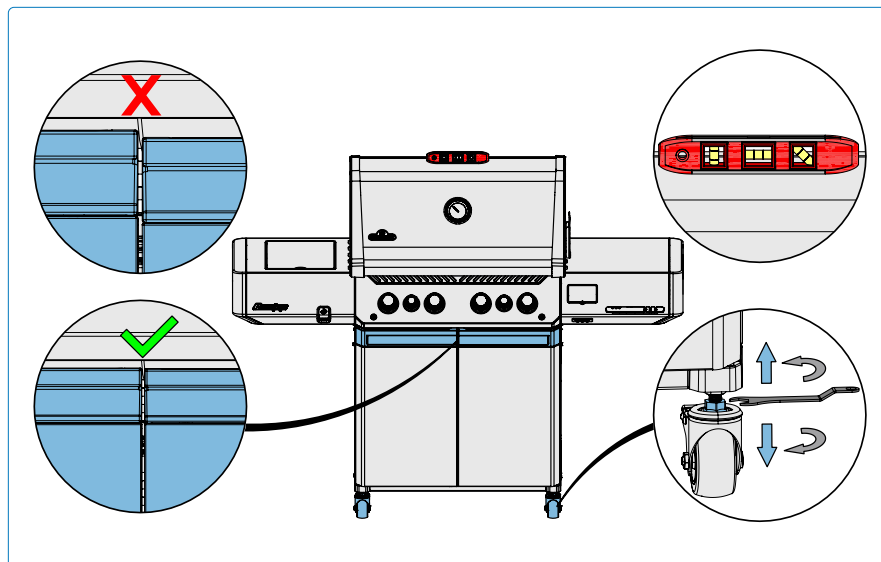

Door Adjustment

The appliance cart doors can be adjusted if they are uneven.

6. Locate the adjustment bracket at the top of the door.
7. Using a screwdriver, turn the door adjustment screw clockwise to raise the door, or counterclockwise to lower it.
8. After one or two turns of the screwdriver, open and close the door and check alignment at the top of the doors.
9. If necessary, repeat these steps until the doors are aligned.



WARNING!

- Only elevate one side of the appliance at a time. Do not tilt the appliance forward or backward.



BE CAREFUL!

The gas cylinder sits close to the ground. Increase the appliance caster height before moving it across uneven terrain to avoid damaging the gas cylinder or cylinder tray.

Troubleshooting

Lighting Problems

- Main, rear or side burners will not light with the igniter, but will light with a butane lighter.
- Burners will not cross light each other.

	Possible causes	Solution
Main Burner	JETFIRE™ outlet is dirty or clogged.	Clean JETFIRE™ outlet with a soft bristle toothbrush.
	Dirty or corroded cross light brackets.	Clean or replace as required.
Rear and Side Burners	Dead battery, or installed incorrectly.	Replace with premium heavy-duty battery.
	Loose electrode wire or switch terminal wires.	Check electrode wire is firmly pushed onto the terminal on the back of the igniter. Check the lead wires from the module to the ignition switch (if equipped) are firmly pushed onto their respective terminals.
	Lifting flames on burner.	Close air shutter according to “Maintenance Instructions”- Combustion Air Adjustment section in this Owner’s Manual. IMPORTANT! This must be done by a qualified gas installer.

Noises and Flare-ups

- Humming regulator.
- Excessive flare-ups and uneven heat.

Possible causes	Solution
Normal humming noise on hot days.	This isn’t a defect. It’s caused by internal vibrations in the regulator and doesn’t affect the performance or safety of the grill. Humming regulators WILL NOT be replaced.
The cylinder valve was opened too quickly.	Open cylinder valve slowly.
Sear plates installed incorrectly.	Ensure sear plates are installed with holes towards the front, and the slots on the bottom. See Assembly Instructions Guide.
Improper heating.	Preheat grill with all main burners on high for 10 to 15 minutes.
Excessive grease and ash build on sear plates and in drip pan.	Clean sear plates and drip pan regularly. Do not line pan with aluminum foil. Refer to “Cleaning Instructions” .



WE WANT TO HELP!

Napoleon® is here to ensure your grilling experience is memorable. Contact us if you require additional help.



REGISTER YOUR GRILL!

Go to napoleon.com or your Assembly Guide for replacement parts instructions.

Peeling Paint

- Paint appears to be peeling inside lid or hood.

Possible causes	Solution
Grease build-up on inside surfaces.	This is not a defect. The finish on the lid and hood is porcelain or stainless steel and will not peel. The peeling is caused by hardened grease, which dries into paint-like shards, that flake off. Regular cleaning will prevent this. See " Cleaning instructions ".

Gas Flow

- Low heat or low flame when valve is turned to high.
- Burners burn with yellow flame, accompanied by the smell of gas.
- Flames lift away from burner, accompanied by the smell of gas, and possible lighting difficulties.
- Burner output on HIGH, but setting is LOW. Rumbling noise and fluttering blue flame at burner surface.

Possible causes	Solution
Propane – improper lighting procedure.	Ensure lighting procedure is followed carefully. All gas valves must be in the OFF position when the tank valve is turned on. Turn tank on slowly to allow pressure to equalize. See Operation – " Lighting Instructions ".
Natural gas – undersized supply line.	Pipe must be sized according to installation code.
Both gas propane and natural gas – improper preheating.	Preheat grill with both main burners on high for 10 to 15 minutes.
Possible spider web or other debris.	Thoroughly clean nest or webs out of your burner orifice by removing it and following instructions in this manual. See " Leak Test ".
Improper air shutter adjustment.	Open or close air shutter slightly according to this manual. See " Maintenance Instructions ". IMPORTANT! This must be done by a qualified gas installer.
Lack of gas.	Check gas level in propane cylinder.
Supply hose is pinched.	Reposition supply hose as necessary.
Propane regulator in low flow state.	Turn the burners off and close the tank valve, wait 5 minutes before fully re-opening the valve, allow a few seconds for the pressure to equalize before following the Lighting Instructions to start the grill. Ensure igniting procedure is followed carefully every time you cook. All gas valves must be OFF when the tank valve is turned on. Always open the tank valve slowly.

Infrared Burner Flashes Back

- During operation the burner abruptly makes a loud whoosh sound, followed by a continuous blow-torch type sound and grows dim or has a large flame on start up.

Possible causes	Solution
Ceramic tiles overloaded with grease drippings and build-up. Ports are clogged.	Turner burner OFF and allow to cool for at least 2 minutes. Reignite burner and burn on HIGH for at least 5 minutes, or until the ceramic tiles are evenly glowing red.
Burner overheated because inadequate ventilation. Too much grill surface covered by griddle or pan.	Ensure no more than 75% of the grill surface is covered by objects or accessories. Turn burner OFF and allow to cool for at least 2 minutes. Reignite.
Leaking gasket surrounding the ceramic tile, or a weld failure in the burner housing.	Allow burner to cool and inspect very closely for cracks. Contact your authorized Napoleon dealer to order replacement burner assembly if any cracks are found.

Low Heat Output

Possible causes	Solution
Improper heating.	Preheat grill with both main burners on high for 10 to 15 minutes.

Flare-ups

Possible causes	Solution
Excessive grease and ash build on sear plates and in drip pan.	Clean sear plates and drip pan regularly. Do not line pan with aluminum foil. Refer to " Cleaning Instructions ".

Pairing the App with the Appliance

- On the display, always ensure that the Bluetooth® and Wi-Fi logo icon is flashing, indicating it is ready to pair with a smart device.

App Problem	Possible Causes / Solution
<p>The app is not installed or is not properly installed.</p>	<ul style="list-style-type: none"> • Connect to Internet via Wi-Fi and download the app from the Apple App Store or Google Play™. • Follow prompts to automatically install and open the app. • Check the app icon on home screen. • Uninstall and reinstall app if needed (see "Napoleon Home App" for more details). • Expand app permissions.
<p>The app is installed but shows a screen with a "probe is not connected" text.</p>	<ul style="list-style-type: none"> • Ensure probes are properly inserted into the slots on your appliance. • Maximize receptivity by facing the display on the appliance with the smart device in close range. • Completely close the app and restart it (be familiar with your device's basic operations and settings). • Close out any unnecessary programs on the smart device that may be consuming memory.
<p>The app worked before, but the device name is not listed in the app device list.</p>	<ul style="list-style-type: none"> • App is not searching or not able to find the device. • Click "Try Again" on the "no devices found" page or hit the back button on the "devices found" page to restart scan. • Turn the display off and on by holding the power button for 5 seconds. Ensure Bluetooth® is activated in the mobile smart device settings. • Bring the smart device close to the display unit. • Refresh the memory cache by closing and reopening the app. • Ensure your device's location setting is turned on. • Wait between 30 and 60 seconds between steps.
<p>The appliance lost the connection while in operation and shows a "connection lost" page.</p>	<ul style="list-style-type: none"> • Try to locate cause of frequency interference or physical obstruction. • Ensure both the appliance and smartphone have internet access, and Bluetooth® is enabled on your smartphone. • Toggle the display unit off and on. • Force close and reopen the app as a last resort.
<p>The alarms are not working.</p>	<ul style="list-style-type: none"> • Check the device connection. • Check appropriate sounds or notifications are turned on in your smart device settings. • Check that alarm (or vibrate) notification is selected in the Napoleon Home App.
<p>The appliance will not connect to Wi-Fi.</p>	<ul style="list-style-type: none"> • The appliance only supports the 2.4GHz Wi-Fi band. Check your router settings. Ensure your router is broadcasting in 2.4GHz. Some routers have the ability to broadcast in multiple bands. Check your router's settings to ensure the 2.4GHz band is enabled. • Other electronic devices can interfere with the Wi-Fi signal. Try moving the device away from electronics that might be causing interference.

Compliance

Product Name	Model Number	FCC ID	IC ID
PRESTIGE	P500VX - P665VX	VA8-P665VXRSIBPSS	7114A-P665VXRSI

This device complies with Part 15 of the FCC Rules. Operation is subject to the following two conditions:

1. The device may not cause harmful interference.
2. The device must accept any interference received, including interference that may cause undesired operation. Changes or modifications not expressly approved by the party responsible for compliance could void the user's authority to operate the equipment.

FCC Compliance:

This equipment has been tested and found to comply with the limits for a Class B digital device, pursuant to Part 15 of the FCC Rules. These limits are designed to provide reasonable protection against harmful interference in a residential installation. This equipment generates, uses, and can radiate radio frequency energy and, if not installed and used in accordance with the instructions, may cause harmful interference to radio communications. However, there is no guarantee that interference will not occur in a particular installation.

If this equipment does cause harmful interference to radio or television reception, which can be determined by turning the equipment off and on, the user is encouraged to try to correct the interference by one or more of the following measures:

- Reorient or relocate the receiving antenna.
- Increase the separation between the equipment and receiver.
- Connect the equipment into an outlet on a circuit different from that to which the receiver is connected.
- Consult the dealer or an experienced radio/TV technician for help.

This equipment has been tested and found to comply with the limits for a Class A digital device, pursuant to Part 15 of the FCC Rules. These limits are designed to provide reasonable protection against harmful interference when the equipment is operated in a commercial environment.

This equipment generates, uses, and can radiate radio frequency energy and, if not installed and used in accordance with the instruction manual, may cause harmful interference to radio communications. Operation of this equipment in a residential area is likely to cause harmful interference, in which case the user will be required to correct the interference at his/her own expense.

This equipment complies with FCC radiation exposure limits set forth for an uncontrolled environment. End user must follow the specific operating instructions for satisfying RF exposure compliance. This transmitter must not be co-located or operating in conjunction with any other antenna or transmitter. The mobile device is designed to meet the requirements for exposure to radio waves established by the Federal Communications Commission (USA).

These requirements set a SAR limit of 1.6 W/kg averaged over one gram of tissue. The highest SAR value reported under this standard during product certification for use when properly worn on the body is 0.515 W/kg.

This equipment complies with FCC radiation exposure limits set forth for an uncontrolled environment. This equipment should be installed and operated with a minimum distance of 20cm between the radiator & your body. This transmitter must not be co-located or operating in conjunction with any other antenna or transmitter.

ISED Canada Statement:

This device contains license-exempt transmitter(s)/receiver(s) that comply with Innovation, Science and Economic Development Canada's license-exempt RSS(s). Operation is subject to the following two conditions:

1. This device may not cause interference; and
2. This device must accept any interference, including interference that may cause undesired operation of the device.

Radio Equipment Directive:

Hereby, Napoleon® declares that the radio equipment type PRESTIGE P500VX - P665VX is in compliance with Directive 2014/53/EU.

Radiation Exposure: This equipment complies with Canada radiation exposure limits set forth for an uncontrolled environment.

RF Exposure Statement:

To maintain compliance with IC's RF Exposure guidelines. This equipment should be installed and operated with minimum distance of 20cm the radiator your body.

This device and its antenna(s) must not be co-located or operation in conjunction with any other antenna or transmitter.

NAPOLEON® PRODUCT WARRANTY



FOR PRESTIGE® CARTS AND BUILT-IN HEADS President's Limited Lifetime Warranty on Napoleon® Gas Grills

NAPOLEON® warrants that the components of your new NAPOLEON® product will be free from defects in materials and workmanship from the date of purchase for a period of:

Aluminum Castings / Stainless Steel Frame.....	Lifetime*
Stainless Steel Lid.....	Lifetime*
Porcelain-Enameled Lid.....	Lifetime*
Stainless Steel Cooking Grids.....	Lifetime*
Stainless Steel Side Table.....	Lifetime*
Stainless Steel Tube Burner.....	10 Years ^{plus Id}
Porcelain-Coated Cast Iron Cooking Grids.....	10 Years ^{plus Id}
Stainless Steel Flame Arrester Inserts.....	5 Years ^{plus Id}
Stainless Steel Infrared Burner for Rotisserie.....	5 Years ^{plus Id}
Bottom Ceramic Infrared Burner or Ceramic Infrared Side Burner (excluding screen).....	5 Years ^{plus Id}
Ceramic Infrared Burner for Rotisserie (excluding mesh).....	5 Years ^{plus Id}
Electrical Components.....	3 Years
All Other Parts.....	2 Years

Plus Id: refers to an extended warranty period, during which we supply spare parts to the purchaser at 50% of the current retail price for the lifetime* of the grill.

Plus 15: refers to an extended warranty period, during which we supply spare parts to the purchaser at 50% of the current retail price for an additional 15 years.

Plus 10: refers to an extended warranty period, during which we supply spare part to the purchaser at 50% of the current retail price for an additional 10 years.

***Lifetime:** refers to a warranty period of 30 years.

This warranty is valid in: the European Union, Switzerland, Andorra, San Marino, Norway, Iceland and Liechtenstein.

The customer's legal entitlements in the event of defects in accordance with WKRL - (EU) 2019/711) are not affected, restricted or altered by the present warranty. The exercise of statutory entitlements is to take place free of charge.

WARRANTY CONDITIONS AND LIMITATIONS

NAPOLEON® guarantees that its products are free from defects exclusively to the original purchaser, and only insofar as the purchase took place through an official NAPOLEON® dealer. The following conditions and restrictions apply:

The present manufacturer's warranty is not transferable nor viable for extension under any circumstances or by any of our representatives. The gas grill must be installed by a licensed, authorized service technician or contractor. Installation must take place in accordance with the installation instructions provided, as well as all local and national building and fire codes.

This limited warranty does not cover damage caused by improper operation, lack of maintenance, grease fire, environmental exposure, accidents, modification, abuse, or neglect. The installation of spare parts from other manufacturers voids the present warranty. The

discoloration of plastic elements due to the application of chemical cleaning agents or exposure to sunlight is not covered under this warranty.

This warranty also excludes any of the following: Scratches, dents, paint defects, coatings, corrosion or discoloration caused by exposure to heat or abrasive and chemical cleaners, as well as chips to porcelain-coated parts and any components used in the installation of the gas grill. If a part deteriorates to the point where it becomes inoperable (due to rusting or burning through) within the warranty period, the customer will be issued with a replacement part.

After the first year, NAPOLEON® has the authority under this warranty (President's Limited Lifetime Warranty, 15 Year Limited Warranty, 10 Year Limited Warranty, 3 Year Limited Warranty) to waive any warranty obligation at its free discretion by refunding the original purchaser to the tune of the wholesale price of the relevant defective warranty parts.

NAPOLEON® accepts no responsibility for any installation, labor hours or other costs or expenses associated with the reinstallation of a warranty part. Costs of this nature are not covered by the present warranty.

Notwithstanding any regulations under this warranty (President's Limited Lifetime Warranty, 15 Year Limited Warranty, 10 Year Limited Warranty, 3 Year Limited Warranty), NAPOLEON®'s liability under this warranty is defined by the foregoing, and does not cover any incidental, consequential, or indirect damage in any case whatsoever.

This warranty defines NAPOLEON®'s duties and liability with respect to the NAPOLEON® gas grill. NAPOLEON® assumes no further liability in connection with the sale of this product, nor does it authorize any third party to assume any other liability on its behalf.

NAPOLEON® assumes no responsibility for: Overheating, extinguishing of the flame by environmental factors such as strong winds or inadequate ventilation.

NAPOLEON® does not accept liability for any damage to the gas grill caused by the weather, hail, rough handling, aggressive chemicals or cleaning agents.

Warranty claims must be accompanied by the proof of purchase or a copy thereof stating the serial and model number.

NAPOLEON® reserves the right to have the product or any part thereof inspected by one of its representatives prior to the fulfillment of any warranty obligation.

NAPOLEON® does not bear shipping costs, labor hours or export duties.

GUARANTOR:

NAPOLEON® EUROPE | WOLF STEEL EUROPE B.V.
De Riemsdijk 22 | 4004LC | Tiel | Gelderland Netherlands

+31 (0) 88 588 66 55
eu.info@napoleon.com

5 YEARS IANS



Celebrating 50 Years of Home Comfort Solutions.



NAPOLEON® products are protected by one or more U.S. and Canadian and/or foreign patents or patents pending.



Address

Wolf Steel Ltd.
De Riemsdijk 22, 4004 LC,
Tiel, The Netherlands
10-12 Home Farm, Meriden Road,
Berkswell, CV7 7SL,
United Kingdom
24 Napoleon Road, Barrie,
Ontario, L4M 0G8, Canada



Telephone

Europe
+31 (0) 88 588 66 55

Online

✉ eu.info@napoleon.com
🌐 www.napoleon.com