

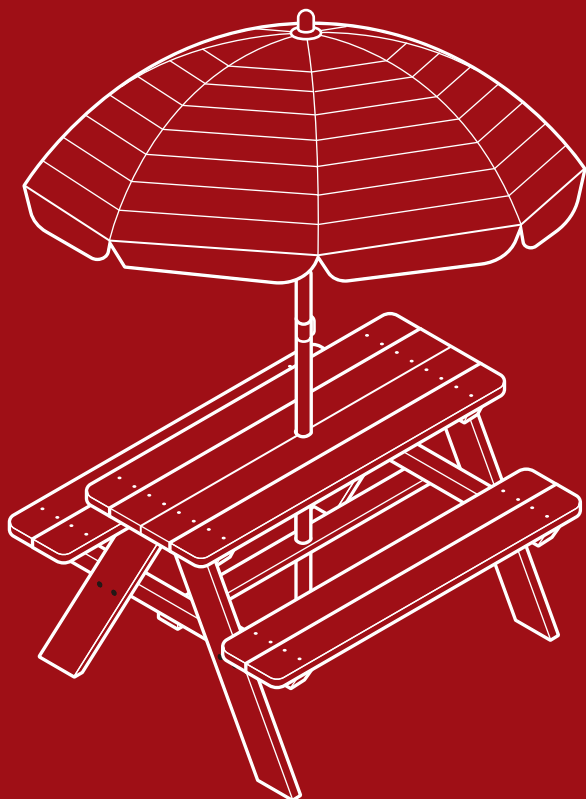

BEST CHOICE
PRODUCTS



INSTRUCTION MANUAL

Child's Picnic Table
with Umbrella

SKY6737 + SKY6738 + SKY7694 + SKY7695 + SKY7696
SKY7697 + SKY7698

WARNING

ADULT ASSEMBLY REQUIRED

NOTICE

Please retain these instructions for future reference.

- Please do not exceed the weight limitations of this item.
- Do not stand on or use any part of this item as a step ladder.
- Firmly secure all bolts, screws, and knobs before use.
- Reconfirm that all bolts, screws, and knobs are secure every 90 days.
- Fasten screws loosely during initial assembly. Do not firmly tighten the screws until the item is completely assembled.
- Do not use or store this item in the proximity of open flame or flammable/combustible chemicals.
- Be aware this product includes an umbrella with a pointed tip, handle with care.
- If any parts are missing, broken, damaged, or worn, stop using this product until repairs are made and/or factory replacement parts are installed.
- Do not use this item in a way inconsistent with the manufacturer's instructions as this could void the product warranty.
- This product is intended for residential use only.

TOOLS REQUIRED



PHILLIPS
SCREWDRIVER



ALLEN WRENCH
(PROVIDED)



AGE RANGE:
3 - 7 YEARS OLD



220 LBS
OVERALL
CAPACITY



2 PERSON
ASSEMBLY



UP TO 30 MIN.
ASSEMBLY

HARDWARE

1

M3.5 x 40mm
SCREW



36 PCS

2

M6 x 45mm
SCREW



16 PCS

PARTS

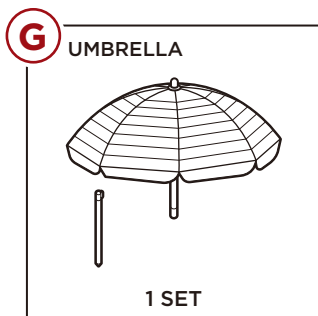
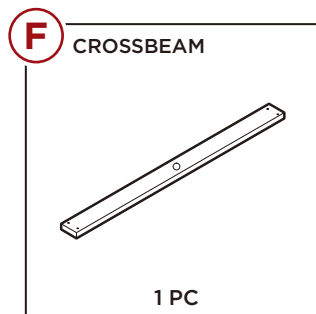
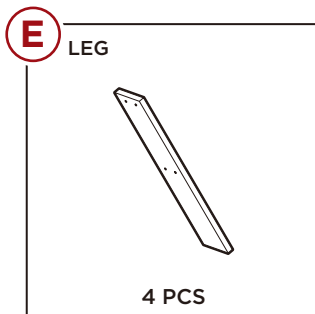
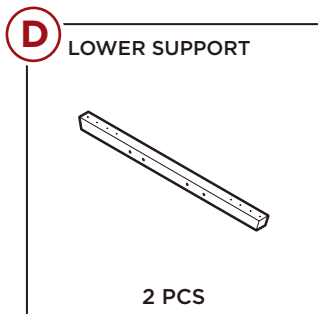
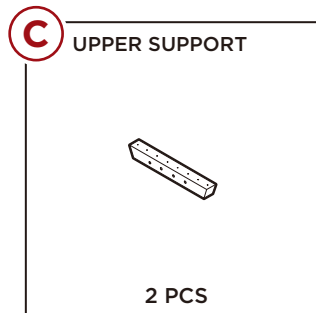
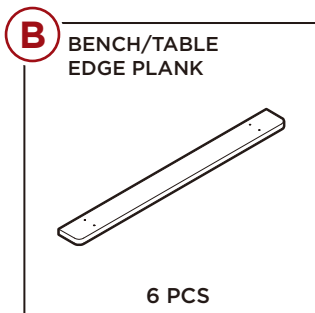
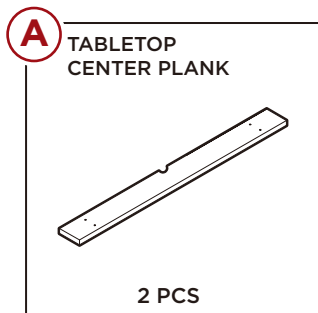

BEFORE ASSEMBLY

Hardware should be inserted through the indented section of the pre-drilled holes

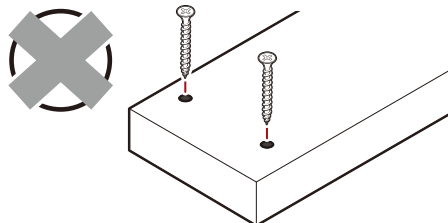
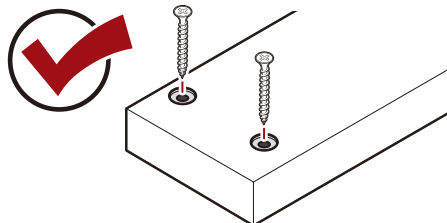

PRODUCT ASSEMBLY

1

Locate one **part E leg** and attach one **part C upper support** and one **part D lower support** with four **part 2 screws**, two screws per support.

Attach a second leg to the assembly with four **part 2 screws**.

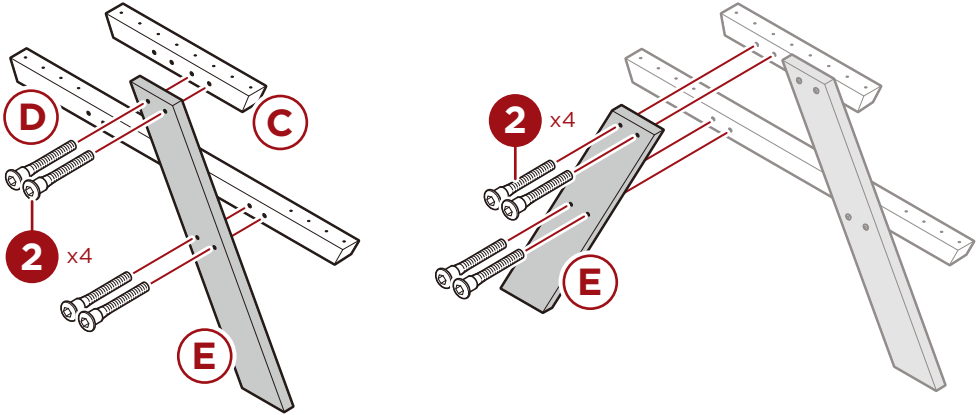

2

Repeat step 1 to assemble a second leg set, then with a second person, attach two **part A tabletop center planks** to the **part C upper supports** with eight **part 1 screws**, four screws per plank.

Be sure each center plank is properly aligned before proceeding to the next step.

NOTE: Make sure the upper and lower supports face one another with the legs on the outer edges.

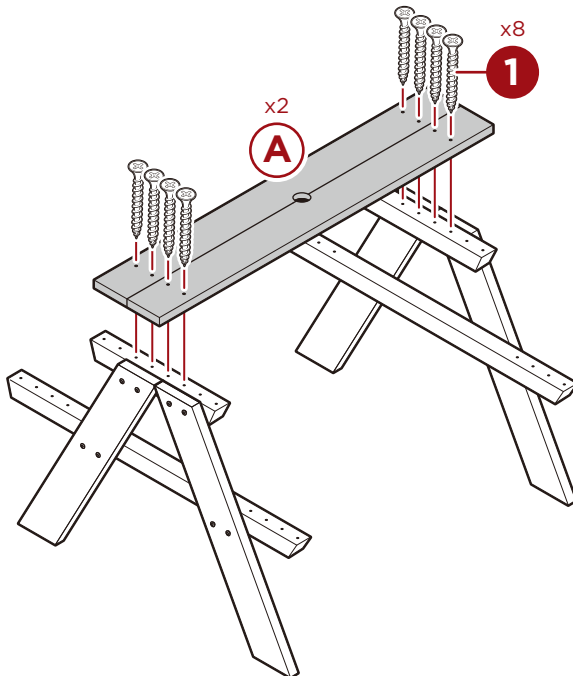

PRODUCT ASSEMBLY

3

Attach two **part B** planks to the **part C** upper supports with eight **part 1** screws, four screws per plank.

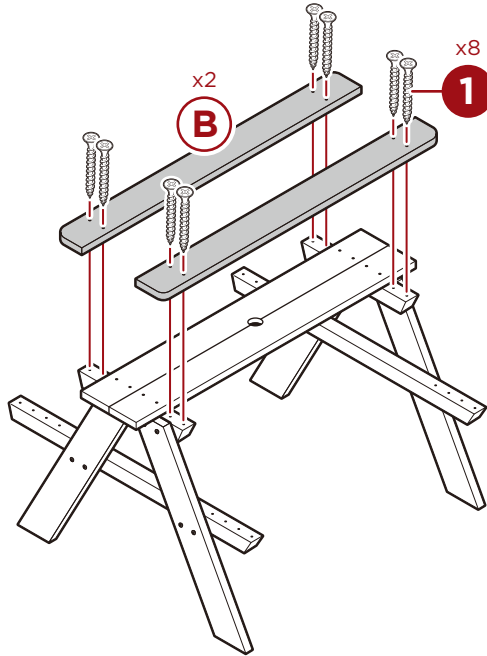

4

Attach four **part B** planks to the **part D** lower supports with sixteen **part 1** screws two planks per side and four screws per plank.

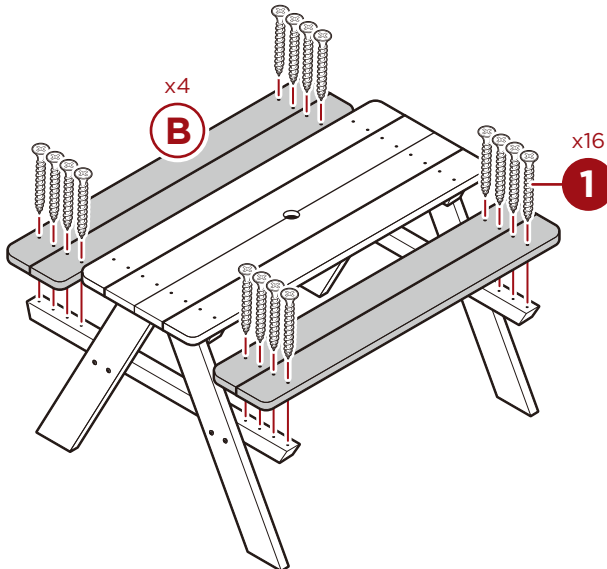

PRODUCT ASSEMBLY

5

With a second person, flip the assembly so the tabletop sits on the ground, attach the **part F crossbeam** to the two **part D lower supports** with four **part 1 screws**.

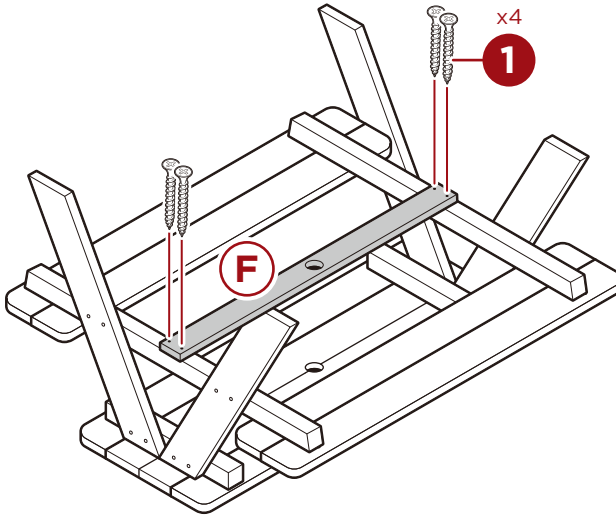

6

Flip the table upright, then locate both halves of the **part G umbrella**. Lift the lever on the lower section, then insert the top/canopy section into the opening.

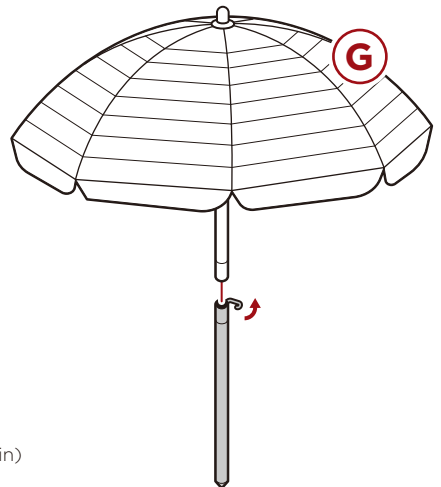
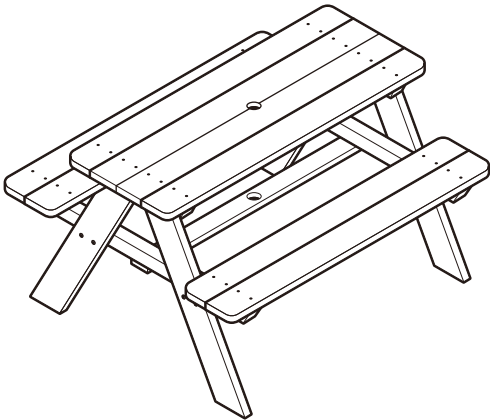

NOTE: Please add minimum insertion depth (2.5 in) of top section into the lower section.

PRODUCT ASSEMBLY

7

Lower the lever to secure the canopy, then insert the assembled umbrella into the opening in the center of the **part A tabletop center planks**.

Open the **part G umbrella** by pushing the canopy upward until you hear an audible click.

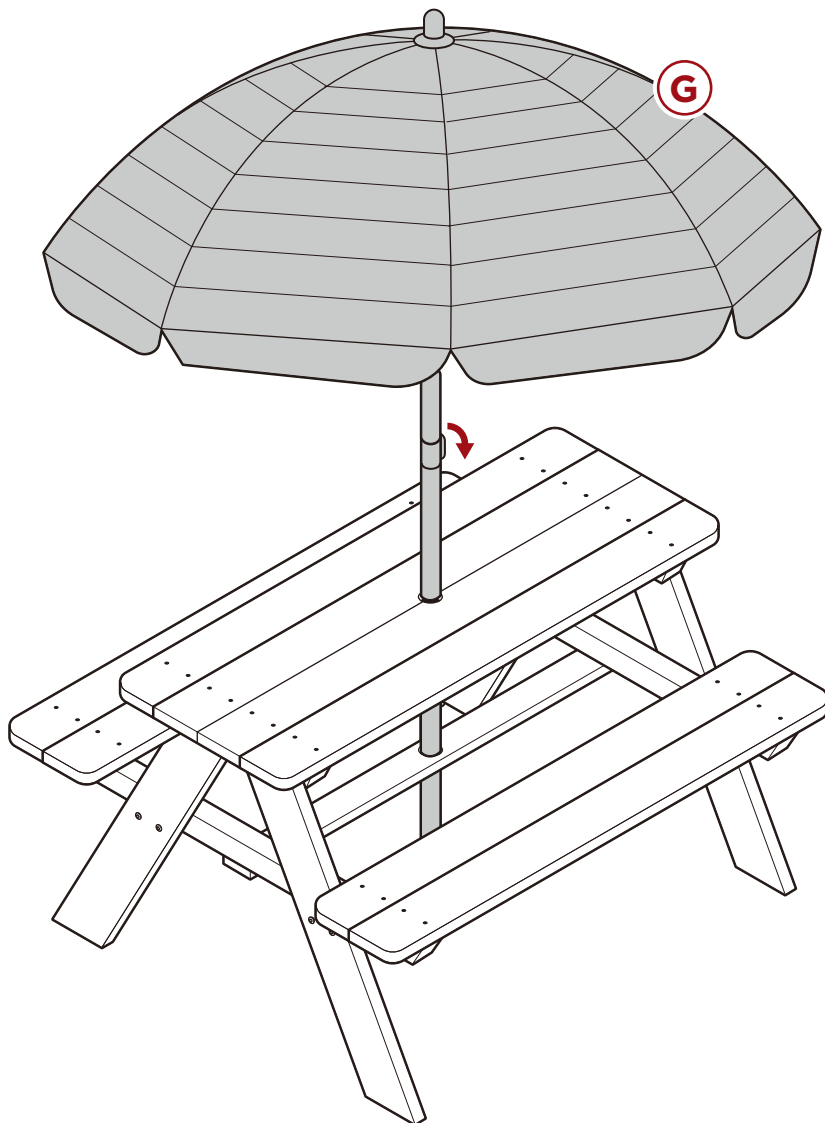



HELP CENTER



Question about your product? We're here to help. Visit us at:

help.bestchoiceproducts.com



Chat Support



Product Inquiry



Orders FAQ



Product Assembly



Returns & Refunds

PRODUCT WARRANTY INFORMATION

All items can be returned for any reason within 60 days of the receipt and will receive a full refund as long as the item is returned in its original product packaging and all accessories from its original shipment are included. All returned items will receive a full refund back to the original payment method. All returned items will not be charged a re-stocking fee.

All returned items require an RA (Return Authorization) number, which can only be provided by a Best Choice Products Customer Service Representative when the return request is submitted. Items received without an RA may not be accepted or may increase your return processing time. Once an item has been received by Best Choice Products, refunds or replacements will be processed within 5 business days.

All returns must be shipped back to the Best Choice Products Return Center at the customer's expense. If the reason for return is a result of an error by Best Choice Products then Best Choice Products will provide a pre-paid shipping label via email. Boxes for return shipping will not be provided by Best Choice Products, and is the customer's responsibility to either use the original shipping boxes or purchase new boxes.

Pictures may be required for some returns to ensure an item is not damaged prior to its return. Items returned are not considered undamaged until they are received by Best Choice Products and verified as such. All damages to items are the customer's responsibility until the item has been received by and acknowledged by Best Choice Products as undamaged.

© Best Choice Products, Inc. All rights reserved. Distributed by Best Choice Products, Inc. Tustin, CA 92780

WARNING

Manufacturer and seller expressly disclaim any and all liability for personal injury, property damage or loss, whether direct, indirect, or incidental, resulting from the incorrect attachment, improper use, inadequate maintenance, unapproved modification, or neglect of this product.