

## WALL-MOUNT INSTRUCTIONS

FOR 30", 36", AND 48" FLOATING VANITIES

**NOTE:** These instructions are to be used on vanities without legs. If installing legs, follow the leg assembly instructions on page 3 and 4.

**TOOLS NEEDED:** Powered drill, 1/4" drill bit, tape measure, level, non-acidic silicone, pencil, and Phillips screwdriver.

### PARTS IDENTIFICATION:

		QTY
<b>A</b>	Vanity (30", 36", or 48")	1
<b>B</b>	Vanity Top	1
<b>C</b>	Wall Mounting Brackets	2
<b>D</b>	Mounting Bracket Screws	6
<b>E</b>	Plastic Anchors*	6

\* Not for use with metal studs. If installing on metal studs, please use mounting hardware designed for the specific application (not provided).

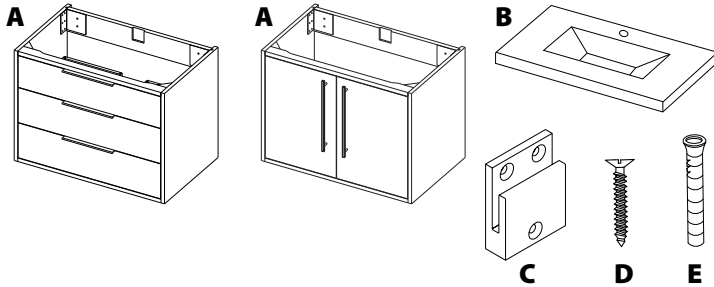

## HOLLOW WALL INSTALLATION

### STEP 1

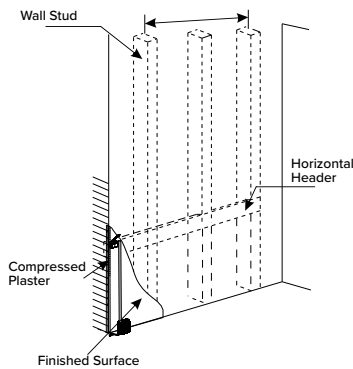

Install in-wall horizontal header at framing stage factoring in desired height of vanity (**A**) and sink. Install the center of the header at 35" if using Jeffrey Alexander vanity legs. Header board height will vary if using other legs or no legs.

### STEP 2

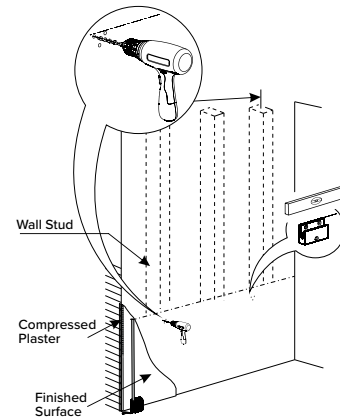

Use level to mark holes for mounting brackets (**C**).

### STEP 3

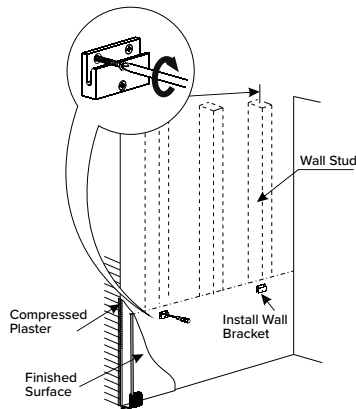

Push plastic anchors (**E**) into the drill holes. Then, install mounting brackets (**C**) using screws (**D**) provided.

### STEP 4

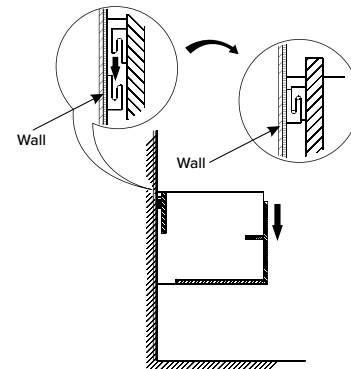

Align the preinstalled brackets on the back of the vanity to the previously installed wall brackets (**C**) and hang the vanity (**A**).

**CAUTION:** To properly support the weight of the vanity and vanity top/sink, secure the vanity to a 2x6 header board (not provided) behind the finished wall or into a concrete wall in accordance with these instructions. Properly secured Wall Mounting Brackets are tested to support a maximum of 500 lbs.

Follow all applicable building and plumbing codes. Hardware Resources highly recommends that you seek a professional installation specialist if you are unsure of any aspect of installation. Hardware Resources is not responsible for any installation error, damages, or injuries resulting from printing errors in instructions.

## LEG INSTALLATION

FOR 30", 36", AND 48" FLOATING VANITIES

**TOOLS NEEDED:** Phillips screwdriver

**PARTS IDENTIFICATION:**

		QTY
<b>A</b>	Vanity (30", 36", or 48")	1
<b>B</b>	Metal Pencil Legs (30" & 36" Qty = 4; 48" Qty = 5)	4/5
<b>C</b>	1/4-20 x 3/4" Screw (for Metal Pencil Legs only)	16
<b>D</b>	Lock Washer (for Metal Pencil Legs only)	16
<b>E</b>	Square Steel Frame Legs	1
<b>F</b>	#8 x 5/8" Pan Head Screws (for Square Steel Frame Legs only)	14
<b>G</b>	Wood Frame Legs	1
<b>H</b>	#8 x 45mm Screws (for Wood Frame Legs only)	14

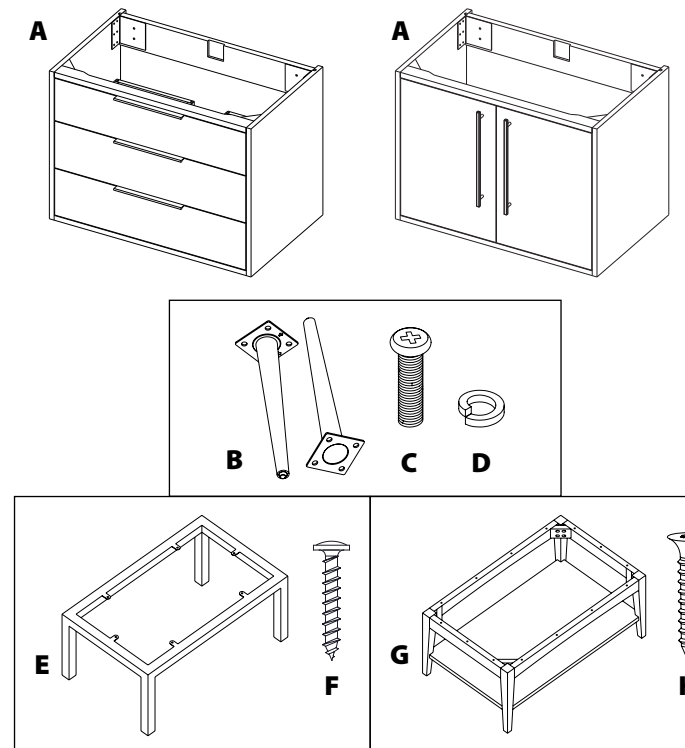

### CONCRETE WALL INSTALLATION

STEP 1	STEP 2	STEP 3
Use level to mark holes for mounting brackets (C). Drill holes 2-9/16" deep into the wall with a 1/4" drill bit. Push plastic anchors (E) into the drill holes.	Install mounting brackets (C) using screws (D) provided.	Align the preinstalled brackets on the back of the vanity to the previously installed wall brackets (C) and hang the vanity (A).

### VANITY TOP INSTALLATION

STEP 1	STEP 2
Carefully place the vanity top POLISHED side down on a soft, smooth surface to prevent scratching or scuffing. Clean the under side of the vanity top with a damp towel to remove any debris to ensure a secure seal to the bowl. Allow time for the vanity top to dry before proceeding to Step 2.	Apply a generous bead of silicone around the entire top edge of the vanity base. Carefully place the top onto the vanity base. The back of the vanity top should be flush with the back of the vanity. Situate the vanity top so that there is equal overhang on each side of the vanity (approximately 1/2" on either side). Allow time for silicone to dry, following silicone manufacturer instructions.

### PENCIL LEG INSTALLATION

Prepare a scratch-resistant surface to work on and place the vanity (A) on the floor top side down. Each leg (B) will be installed into the predrilled holes on the bottom of the vanity unit. Install the screw (C) and lock washer (D) into the four holes of each leg. Repeat for the remaining legs. **NOTE:** Each leg is marked with two arrows on the base to designate the outer corners.

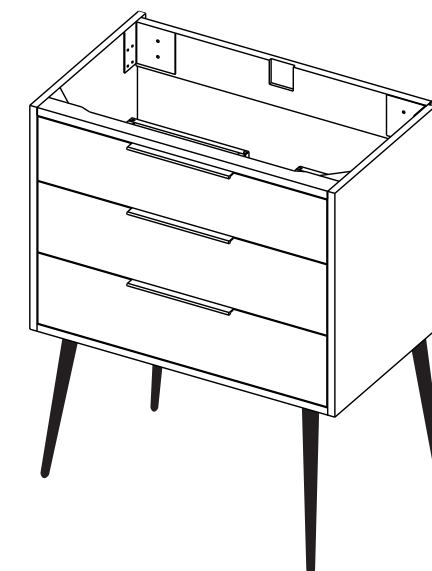

**CAUTION:** To properly support the weight of the vanity and vanity top/sink, secure the vanity to a 2x6 header board (not provided) behind the finished wall or into a concrete wall in accordance with these instructions. Properly secured Wall Mounting Brackets are tested to support a maximum of 500 lbs.

Follow all applicable building and plumbing codes. Hardware Resources highly recommends that you seek a professional installation specialist if you are unsure of any aspect of installation. Hardware Resources is not responsible for any installation error, damages, or injuries resulting from printing errors in instructions.



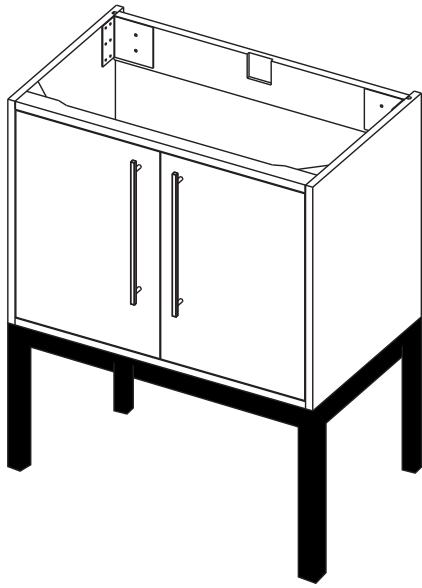

## SQUARE STEEL FRAME INSTALLATION

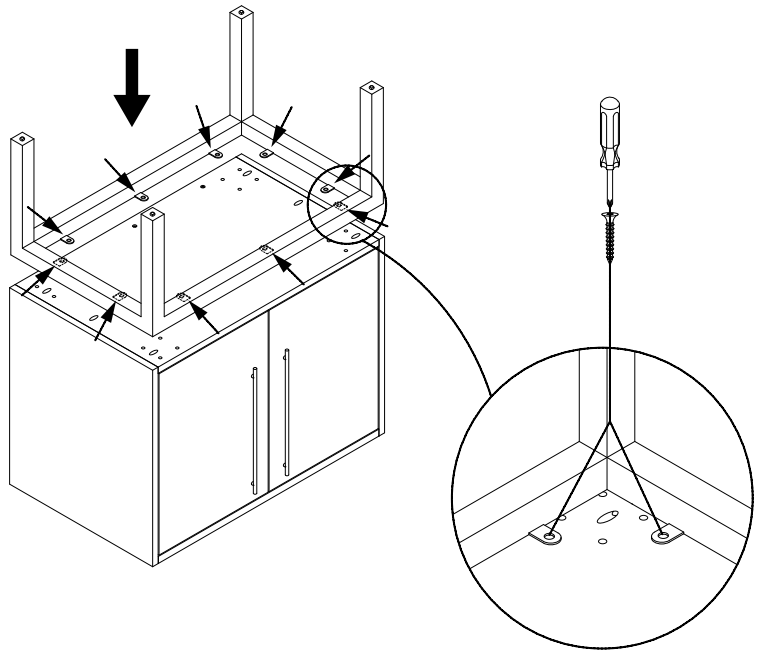

Prepare a scratch-resistant surface to work on and place the vanity (A) on the floor top side down. The frame (E) has predrilled pilot holes. Use the included screws (F) to attach the frame to the vanity unit.

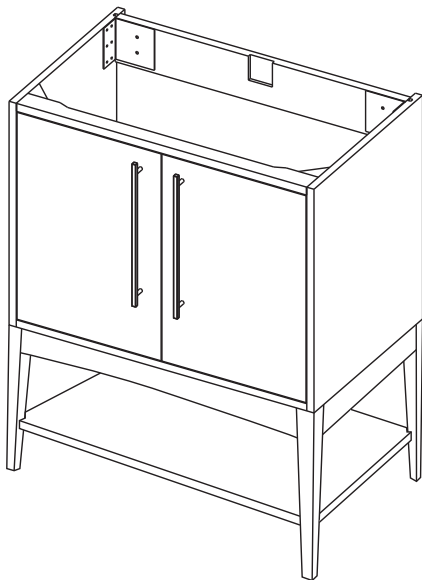

## WOOD FRAME INSTALLATION

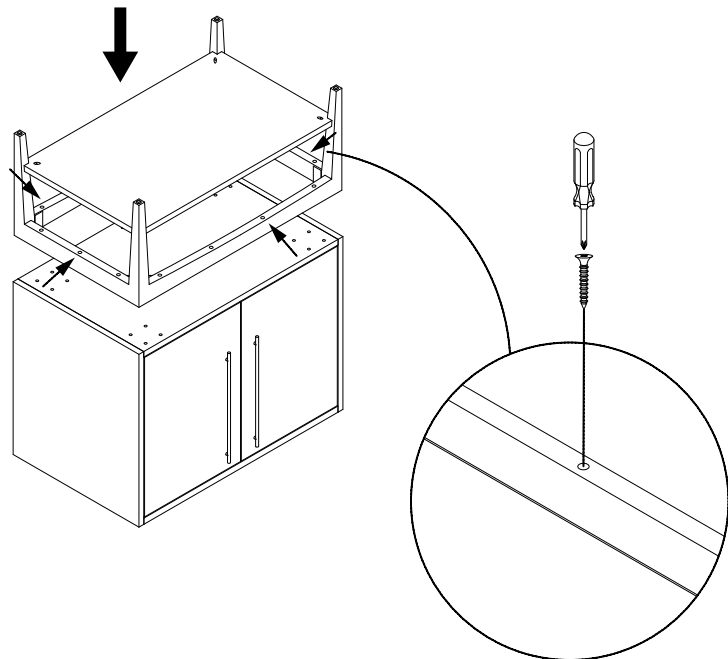

Prepare a scratch-resistant surface to work on and place the vanity (A) on the floor top side down. The frame (G) has predrilled pilot holes. Use the included screws (H) to attach the frame to the vanity unit.

