





ASSEMBLY INSTRUCTION FOR 26142 WRITING DESK

HARDWARE LIST

NO.	ITEM	DESCRIPTIN	QTY.
1		Bolt M8X20 MM	12
2		Flat washer M8X25 MM	12
3		Wrench	1
4		JCB Bolt M6X16 MM	4
5		Allen wrench	1

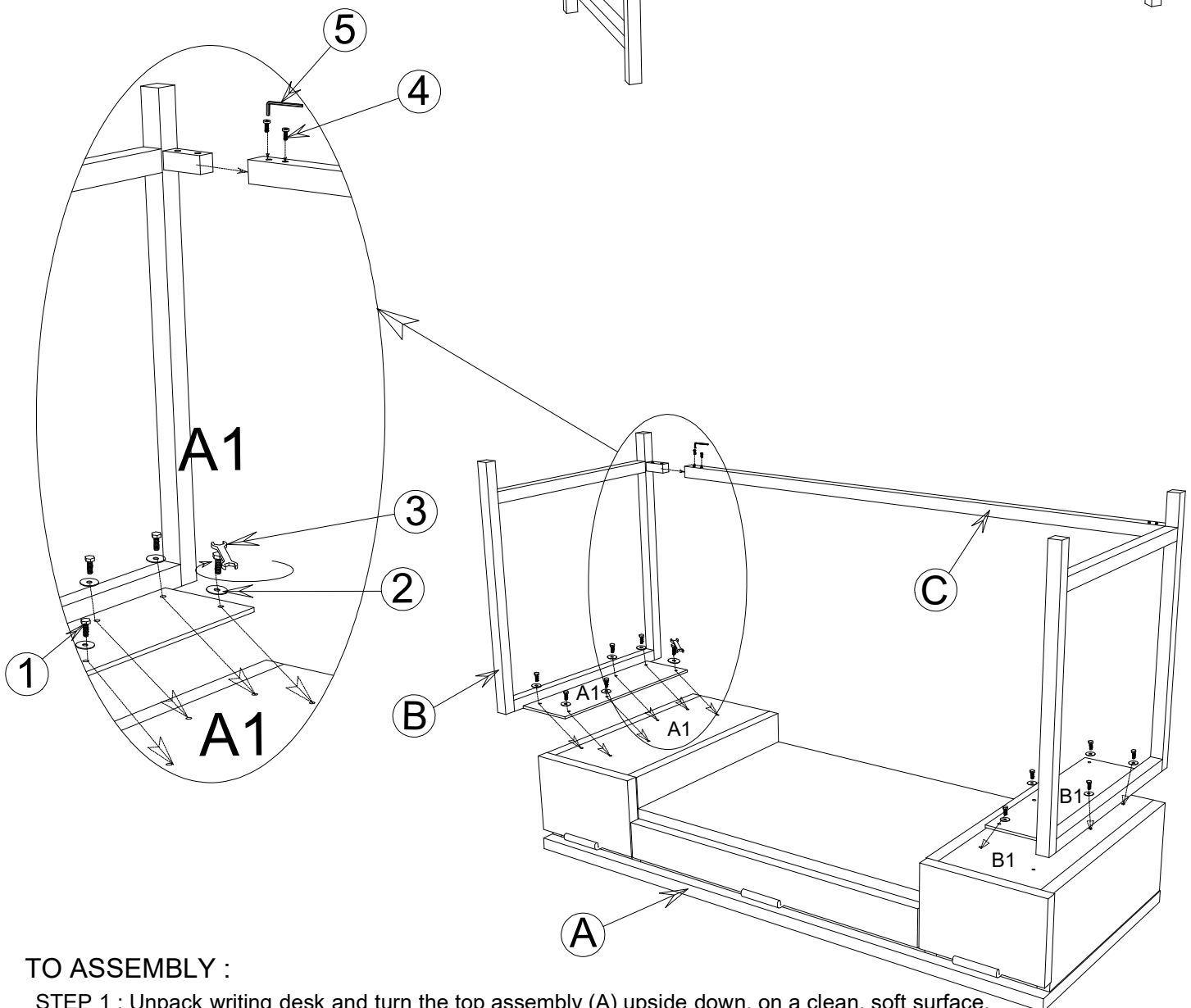
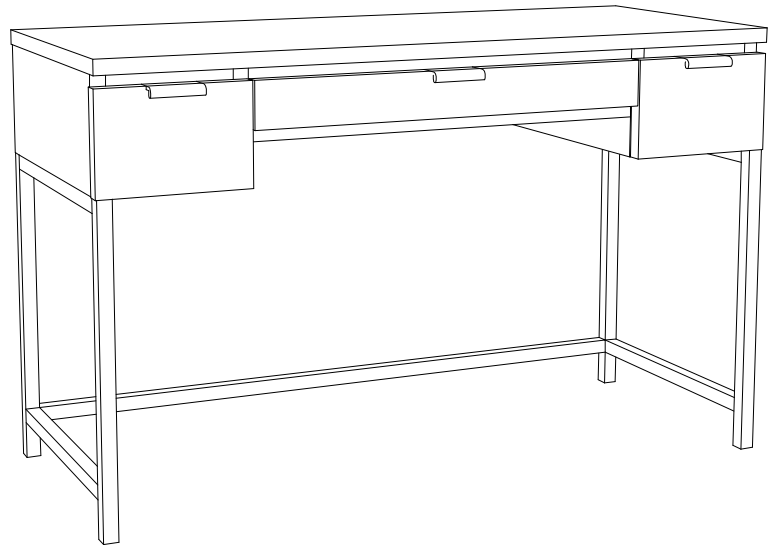

TO ASSEMBLY :

- STEP 1 : Unpack writing desk and turn the top assembly (A) upside down. on a clean, soft surface.
- STEP 2 : Match the iron legs(B). use matching marks A1 & B1 - on top(A) & stretcher (C).
- STEP 3 : Align holes in legs (B) with holes on bottom of desk top(A) & stretcher (C) and slide it into position.
- STEP 4 : Thread the flat washer(2) , bolt (1) & JCB bolt (4) to leg (B) . Do not tighten bolts fully until all bolts are started.
- STEP 5 : Tighten bolts in step 4 fully with wrench (3) & Allen wrench (5) then carefully turn the writing desk upright.