

FLEXSTEEL®



**ASSEMBLY INSTRUCTIONS**

1552 HAVEN

Power Swivel Recliner with  
Power Headrest, Lumbar, Ventilation, Heat & Massage

## IMPORTANT SAFETY INSTRUCTIONS

*READ ALL INSTRUCTIONS BEFORE USING*

**WARNING:** To reduce the risk of burns, fire, electric shock, or injury to people:

1. **DANGER:** To reduce the risk of electric shock-Always unplug this furnishing from the electrical outlet before cleaning.
2. Unplug from outlet before putting on or taking off parts.
3. Close supervision is necessary when used by or near children, or disabled people.
4. Use this furnishing only for its intended use as described in these instructions. Do not use attachments not recommended by the manufacturer.
5. Never operate this furnishing if it has a damaged cord or plug, if it is not working properly, if it has been dropped or damaged, or dropped into water.
6. Keep the cord away from heated surfaces.
7. Never drop or insert any object into any opening.
8. Do not use outdoors. This furnishing is for household indoor use only.
9. To disconnect, turn all controls to the off position, then remove plug from outlet.
10. **WARNING:** Risk of injury - Keep children away from extended foot support.
11. **WARNING:** Risk of injury to persons - do not use this furnishing to support video equipment such as televisions or computer monitors.
12. When not in use, it is recommended that the remote control be stored securely in the pocket on the outside of the arm.

*SAVE THESE INSTRUCTIONS.*

## PARTS LIST

The following components should be included in your box.

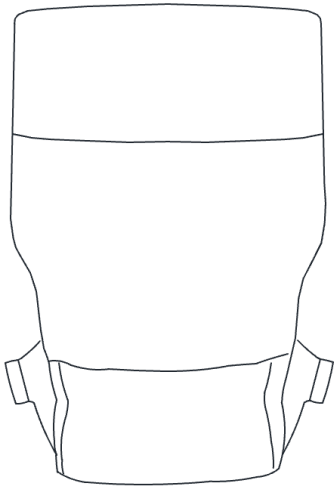

Backrest

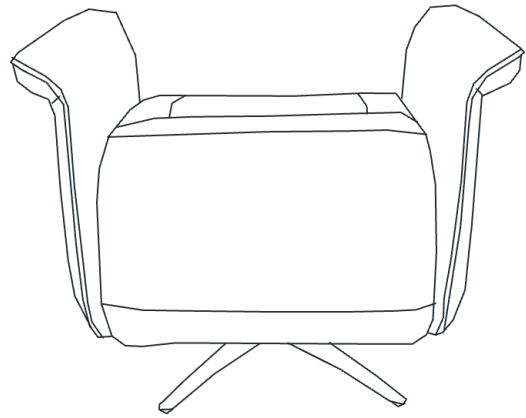

Seat

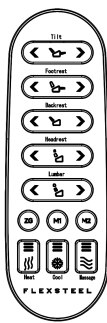

Wireless Remote



Transformer

# ASSEMBLY INSTRUCTIONS

## Step 1: Remove Accessories

Remove the transformer and wireless remote from the back of the seat. (See Figure 1)

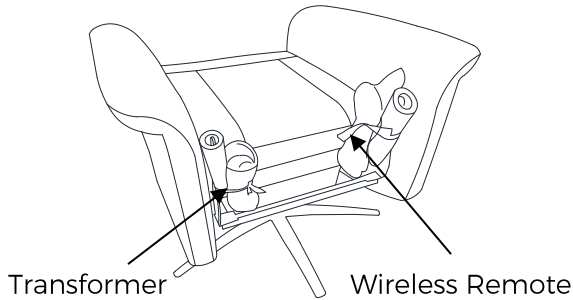

(Figure 1.)

## Step 2: Attach the Backrest

Undo the Velcro flaps on each side of the backrest. Align the backrest with the seat and lower it into place. Ensure the latches fully engage and the backrest is securely locked. Reattach the Velcro flaps. (See Figure 2)

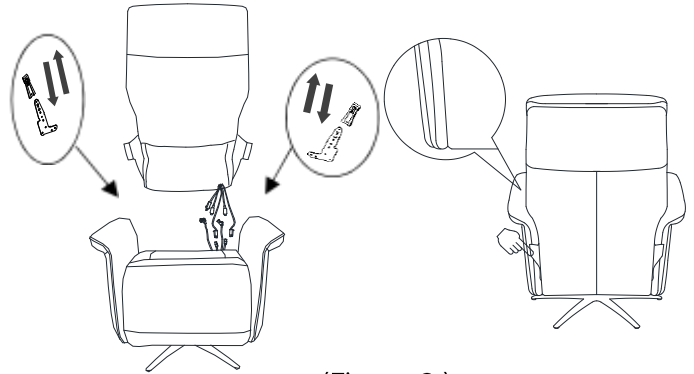

(Figure 2.)

## Step 3: Connect Internal Cables

Carefully tip the recliner forward so it is resting on its chaise. Underneath the back, connect the USB port, headrest, ventilation, heat, and massage cables between the backrest and the seat. Ensure each connector is fully seated. Carefully flip the recliner back to its upright position. (See Figure 3)

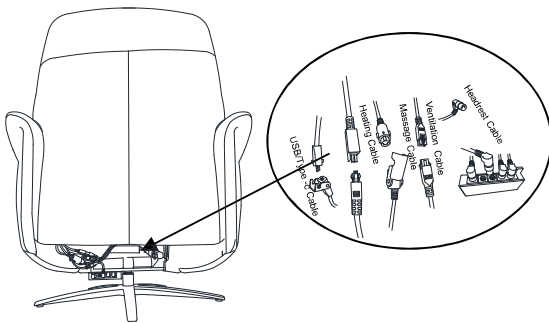

(Figure 3.)

## Step 4: Connect Power

Connect the base motor cable to the transformer. Plug the transformer into a nearby outlet. The power cable routes through the center of the five-star base. (See Figure 4)

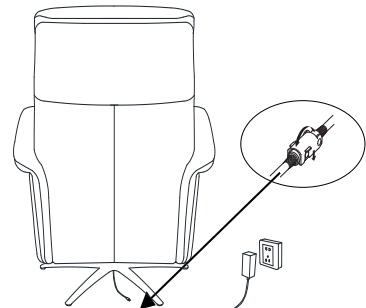

(Figure 4.)

## Step 5: Store the Wireless Remote

Store the wireless remote in the side pocket. (See Figure 5)

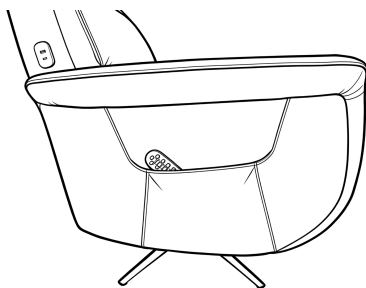

(Figure 5.)

## Step 6: Physical Home Button

If the wireless remote battery is depleted, press the physical Home button to return the chair to its original position. (See Figure 6)

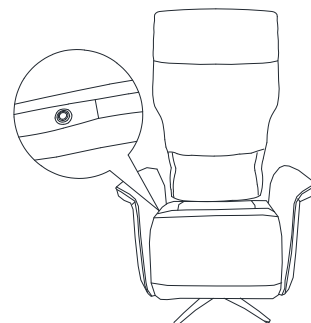

(Figure 6.)

**SIT BACK, RELAX AND ENJOY!**

**TROUBLESHOOTING**

<b>PROBLEM</b>	<b>POSSIBLE FACTORS</b>	<b>SOLUTIONS</b>
Chair doesn't recline	Transformer may not be connected well	<ul style="list-style-type: none"> <li>· Check that the power supply has been correctly connected to transformer and socket</li> <li>· Confirm the wire from chair to transformer is firmly connected</li> </ul>
Power not working	Power outlet on wall not functioning	<ul style="list-style-type: none"> <li>· Check power from your wall outlet</li> <li>· Plug in a different device to make sure outlet has power</li> </ul>
Motor doesn't work	The motor wires may not be properly connected inside back flap of chair	<ul style="list-style-type: none"> <li>· Check that the motor wires have been correctly connected</li> </ul>
The remote doesn't work	Remote has no power	<ul style="list-style-type: none"> <li>· Please check whether the battery in the remote has been installed or installed correctly</li> </ul>
The remote doesn't work	Out of the Bluetooth range	<ul style="list-style-type: none"> <li>· Be in close proximity to the chair</li> </ul>

*When checking connections, unplug the chair from the wall first.*

*After, check the connections and making sure they are connected to the correct connector and tightly secured.*

*Then, plug the chair back into the wall to test your connections.*