

Item#	Material	Thickness	Bright of finish
TOPR61WC	White Carrara Marble	25mm	90%
TOPR61BG	Black Granite	25mm	90%
TOPR61WQ	White Quartz	18mm	90%
TOPR61GQ	Grey Quartz	18mm	90%
TOPR61MG	Grey Marble	18mm	90%
TOPR61LS	Blue Limestone	25mm	20-30%
TOPR61CQ	Calacatta Vienna Quartz	18mm	

THIRD ANGLE PROJECTION

hardware resources

MATERIAL	FINISH	TITLE
		TOPR61
DRAWN BY	DATE	
Tony. Huang	5-15-2024	
DESIGNED BY	DATE	DRAWING NUMBER
APPROVED BY	DATE	SIZE
		A3
		RELEASE LEVEL
		SCALE 1:1
		SHEET 1 OF 1

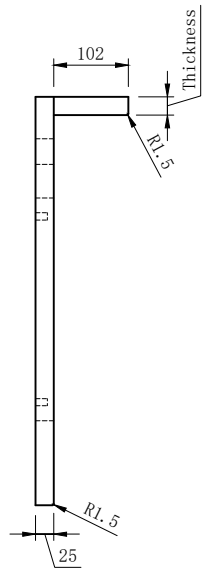
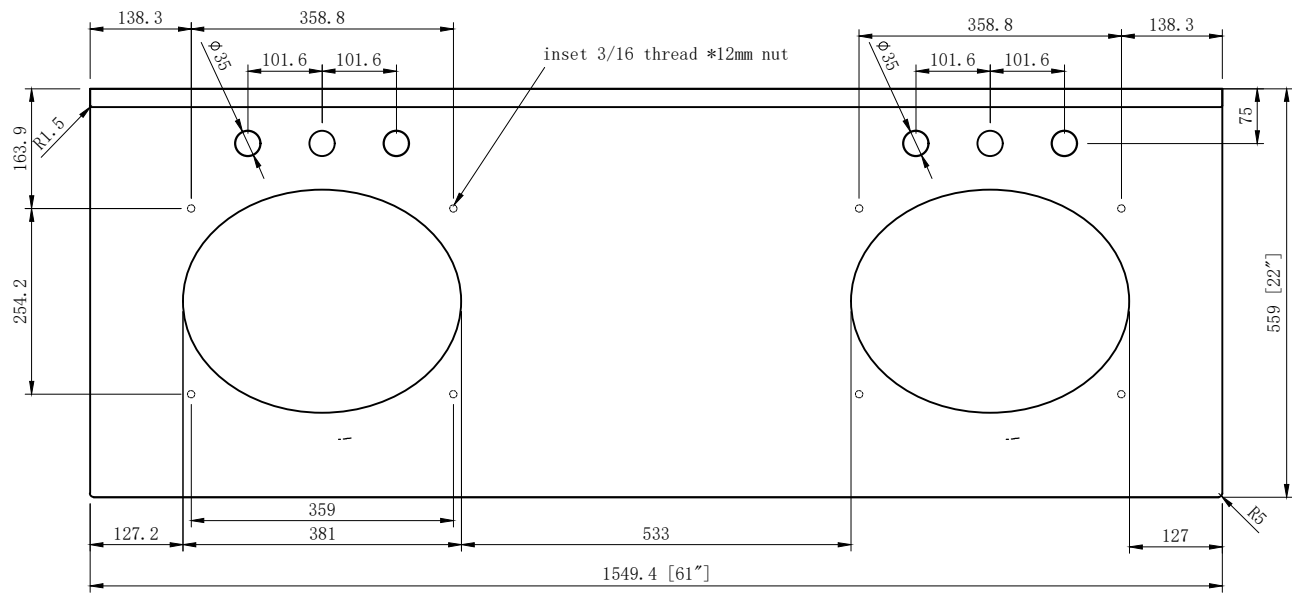
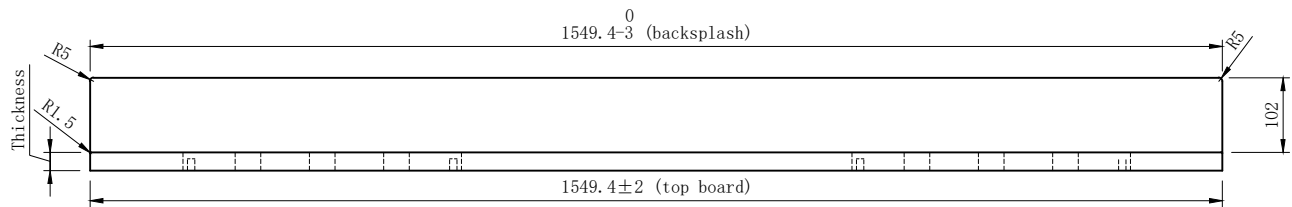

Item#	Material	Thickness	Bright of finish
TOPO61WC	White Carrara Marble	25mm	90%
TOPO61BG	Black Granite	25mm	90%
TOPO61GQ	Grey Quartz	18mm	90%
TOPO61MG	Grey Marble	18mm	90%
TOPO61LS	Blue Limestone	25mm	20-30%
TOPO61CQ	Calacatta Vienna Quartz	18mm	

THIRD ANGLE PROJECTION								hardware resources [®]			
MATERIAL		FINISH									
DRAWN BY		DATE		TOPR61				REV			
Tony.Huang		05-15-24		DRAWING NUMBER				REV			
DESIGNED BY		DATE		DRAWING NUMBER				REV			
APPROVED BY		DATE		SIZE		RELEASE LEVEL		SHEET			
				A3		SCALE 1:1		SHEET 1 OF 1			

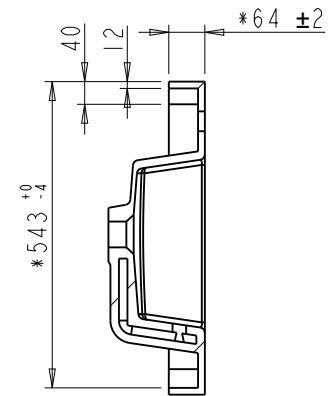
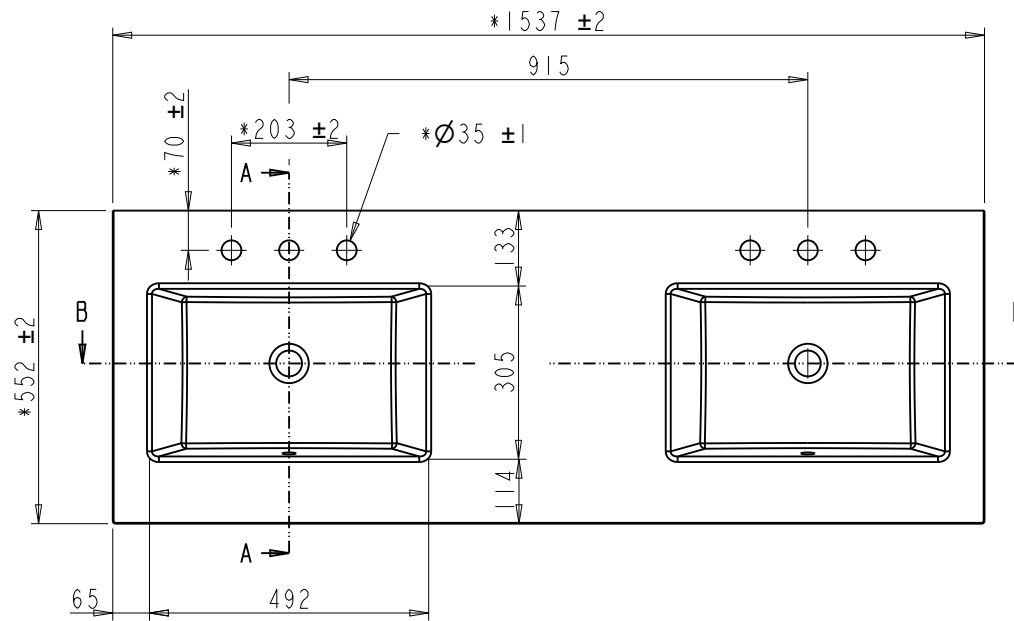

SECTION A-A

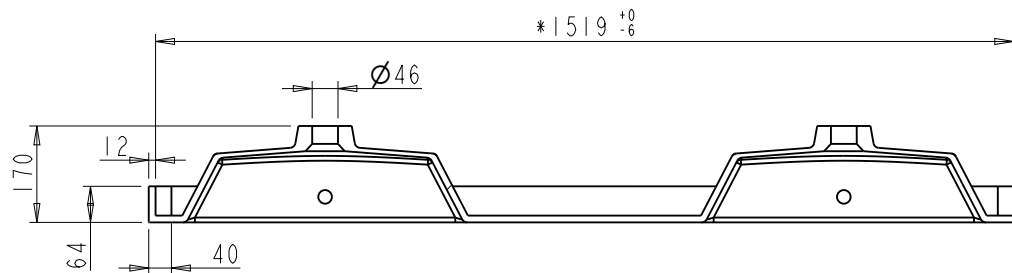
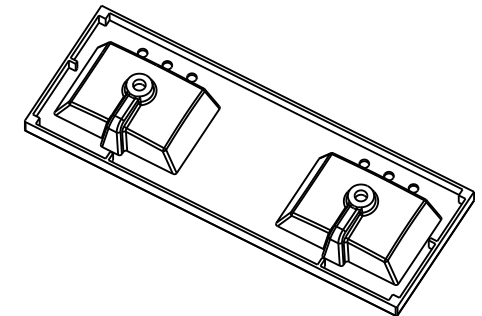
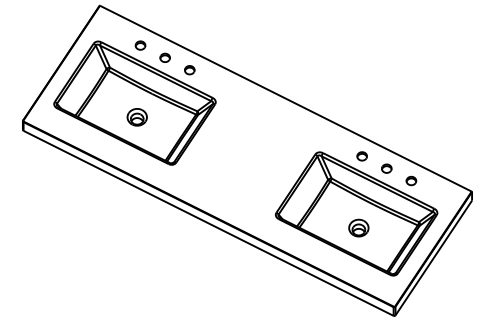

SECTION B-B

<p>hardware resources</p> <p><small>PROPRIETARY AND CONFIDENTIAL</small></p> <p><small>THE INFORMATION CONTAINED IN THIS DRAWING IS THE SOLE PROPERTY OF HARDWARE RESOURCES INC. ANY REPRODUCTION IN PART OR AS A WHOLE WITHOUT THE WRITTEN PERMISSION OF HARDWARE RESOURCES INC. IS PROHIBITED.</small></p>	ITEM:	TOPR6IRE	MATERIAL:	
	FINISH:		WEIGHT:	
	TOLERANCE UNLESS OTHERWISE SPECIFIED:		UNITS:	DATE:
	X ± 0.20 X.X ± 0.10 X.XX ± 0.05 ANGULAR: $\pm 0.5^\circ$		DRAWN BY:	Apr - 18 - 23
DO NOT SCALE DRAWING	SHEET:	APPROVED BY:	DATE:	
	RELEASE LEVEL:	REVISION:		

