









# ASSEMBLY INSTRUCTIONS

24822 - Arm Chair

A		5/16" x 12.5 x 8.5mm	4Pcs
B		5/16	11Pcs
C		5/16 x 19mm	11Pcs
D		5/16 x 45mm	3Pcs
E		5/16 x 76mm	4Pcs
F		4mm	1Pc
G		13mm	1Pc
H		φ8 x 38mm	2Pcs

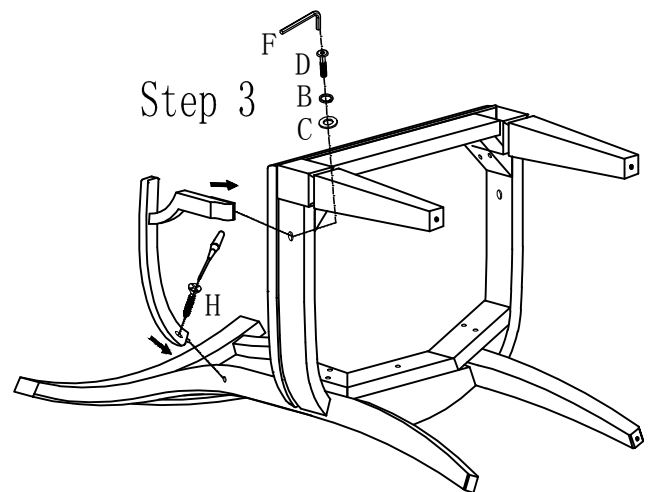
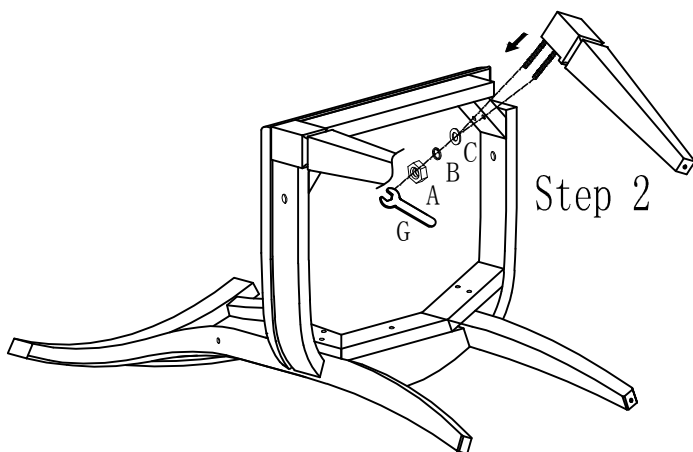
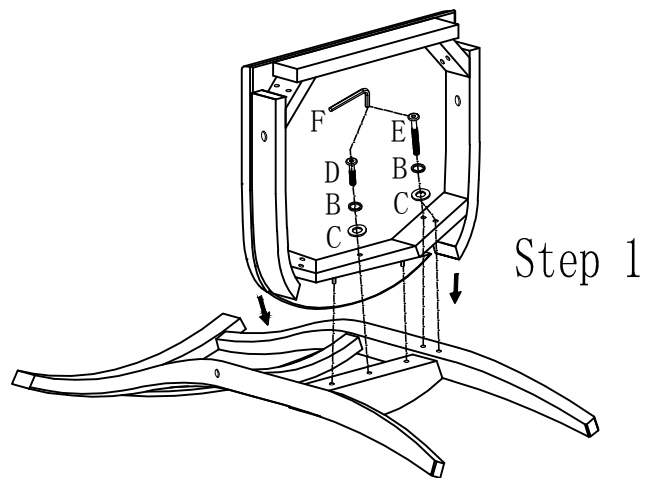

Assemble the chair on soft and clean surface to prevent scratching

Step 1: Assemble the back frame and the chair seat together with Bolt (D, E), Lock washer (B) and Washer (C) using Allen Wrench (F).

Step 2: Assemble the front legs to the chair with Nut (A), Lock washer (B) and Washer (C) using Wrench (G).

Step 3: Finally attach Arm to back legs and to Seat Base Using Bolt (D), Lock washer (B) and Washer (C) using Allen Wrench (F) to back legs with screw (G). Do not tighten Bolt or screw completely

Step 4: Set the chair upright on a flat surface. Adjust front legs so all four chair legs touch the floor, tighten nut completely on front legs. (The seat cushion may need to be loosened to adjust front legs).

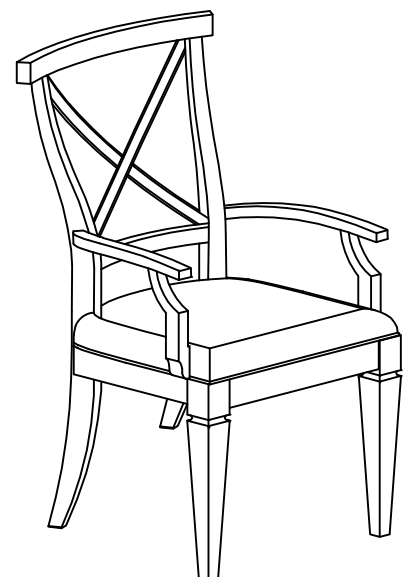

MADE IN VIETNAM