





HEKMAN[®]

A HOWARD MILLER COMPANY

ASSEMBLY INSTRUCTIONS FOR 25320 Rectangle Dining Table

HARDWARE LIST

NO.	ITEM	DESCRIPTION	QTY	NO.	ITEM	DESCRIPTION	QTY
1		BOLT Ø1/4" x 1"	24	2		LOCK WASHER	24
3		FLAT WASHER	24	4		ALLEN WRENCH	1

STEP 2

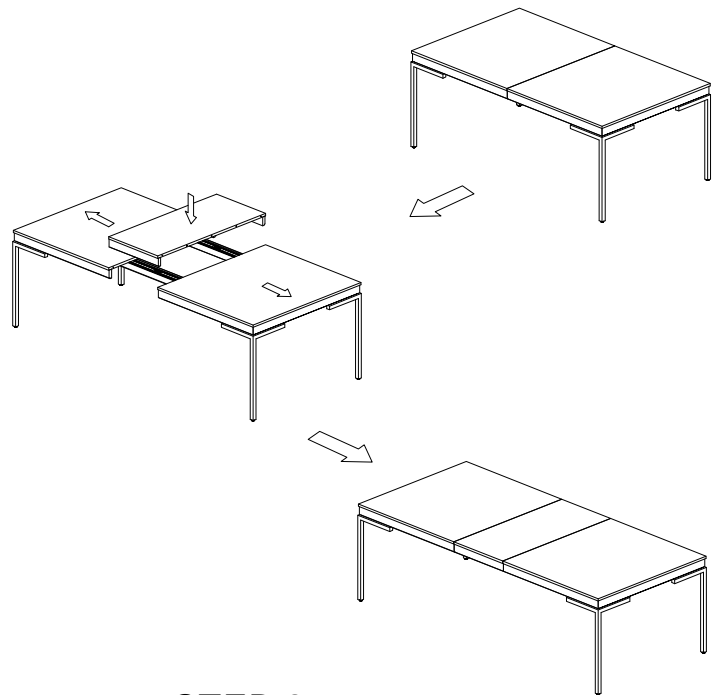
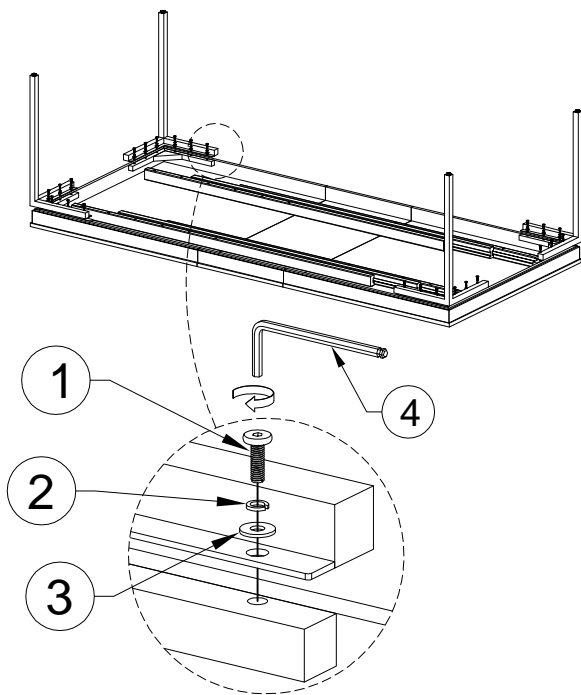

STEP 3

TO ASSEMBLY:

STEP 1: Lay the table top face down on a piece of cloth or carpet to prevent the finish from scratching.

STEP 2: Attach the legs to the table top. Insert the flat washer (3), lock washer (2), with bolt (1) to the table top tighten with allen wrench (4).

STEP 3: Assembly of the product is now completed.

