

Item: BR2DRLEENS

Assembly Instructions



Please visit our website for the most current instructions, assembly tips, to report damage or request parts. www.walkeredison.com

Revised 06/2024-V4

General assembly guidelines

- I. Ensure that all parts and hardware are available before beginning assembly.
- II. Follow each step carefully to ensure the proper assembly of this product.
- III. Two people are recommended for ease in the assembly of this product.
- IV. The three main types of hardware used to assemble this product are wood dowels, screws and bolts.
- V. A phillips head screwdriver, hammer and tape measure is required for the assembly of this product.

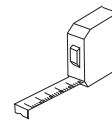
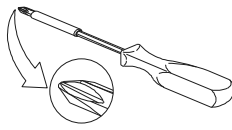
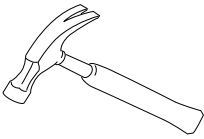

- VI. Power tools should not be used to assemble this product.

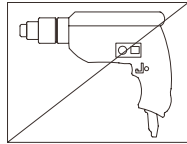

VII. Maintenance Guide

To maintain long term performance and easy gliding of your solid wood drawers, we recommend applying wax to the wooden guide rails.

1. Bee's wax is recommended or Paraffin wax from a standard candle can be used.
2. Apply the wax by rubbing it on the wooden guide rails where there is wood-on-wood contact when opening and closing the drawer. (Wax should be room temperature, do not melt the wax onto the wood)
3. Wax should be applied every few months for the first year and then only when needed after that to keep the drawers sliding smoothly.



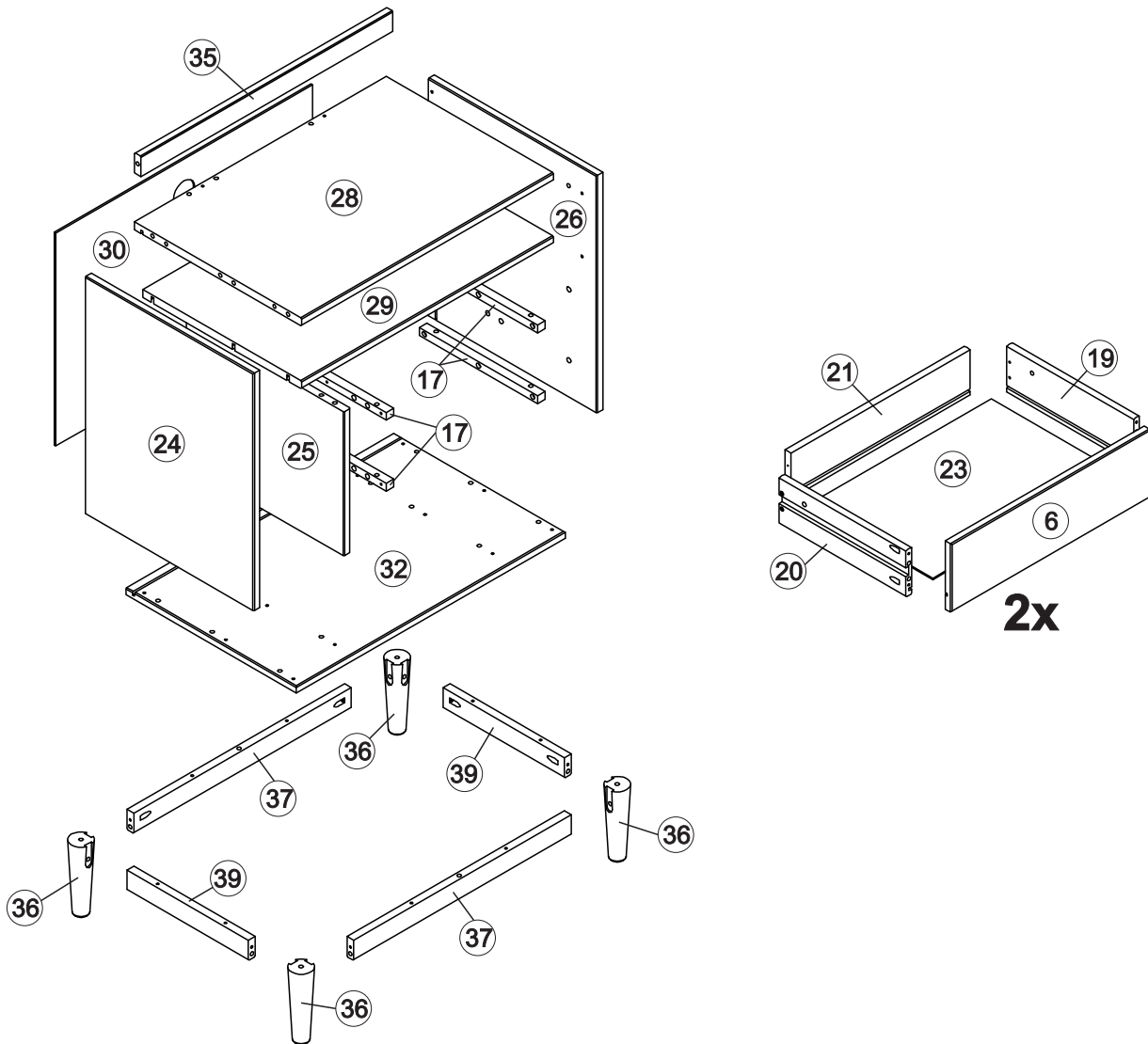





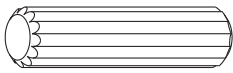
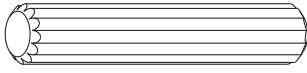
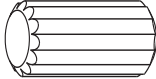

Parts List

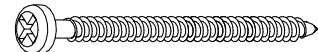

Part #	Description	Qty
6	Drawer front	02 pcs
17	Wood slider	04 pcs
19	Right drawer side	02 pcs
20	Left drawer side	02 pcs
21	Drawer back	02 pcs
23	Drawer bottom	02 pcs
24	Left side panel	01 pc
25	Division	01 pc
26	Right side panel	01 pc

Part #	Description	Qty
28	Top	01 pc
29	Shelf	01 pc
30	Back panel	01 pc
32	Base panel	01 pc
35	Top crossbeam	01 pc
36	Foot	04 pcs
37	Botton front crossbeam	02 pcs
39	Botton side crossbeam	02 pcs

Hardware List

A		Ø8*30mm	Wood dowel	47 pcs
B		Ø8*40mm	Wood dowel	04 pcs
C		Ø10*20mm	Wood dowel	12 pcs
D		Ø3,0*12mm	Screw	04 pcs
E		Ø4,0*25mm	Screw	12 pcs
F		Ø3,5*30mm	Screw	18 pcs
G		Ø4,0*40mm	Screw	22 pcs
H		ø15*30mm	Cam bolt	14 pcs
I		ø15*10mm	Cam lock	14 pcs
J		-	Handle	02 pcs
K		Ø8*8mm	Cam bolt	06 pcs
L		-	Plastic lock	06 pcs
M		-	Slap hole	06 pcs

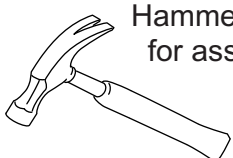

Hammer recommended
for assembly (not included)



Phillips head screwdriver required
for assembly (not included)

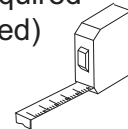

Tape measure
required
for assembly
(not included)

*The hardware quantities listed above are required for proper assembly.
Some extra hardware may also have been included.*

Step 1

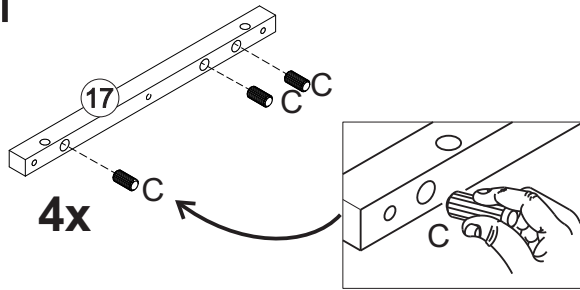

Attention to the
dowel size:
Ø10*20mm

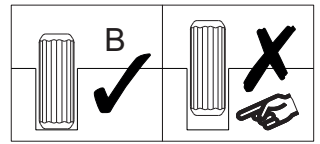

Insert wood dowel (C) into part 17.

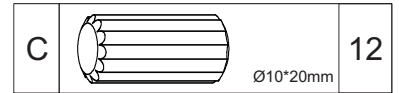

Step 2

Please assemble on
a clean soft surface
to avoid damage.

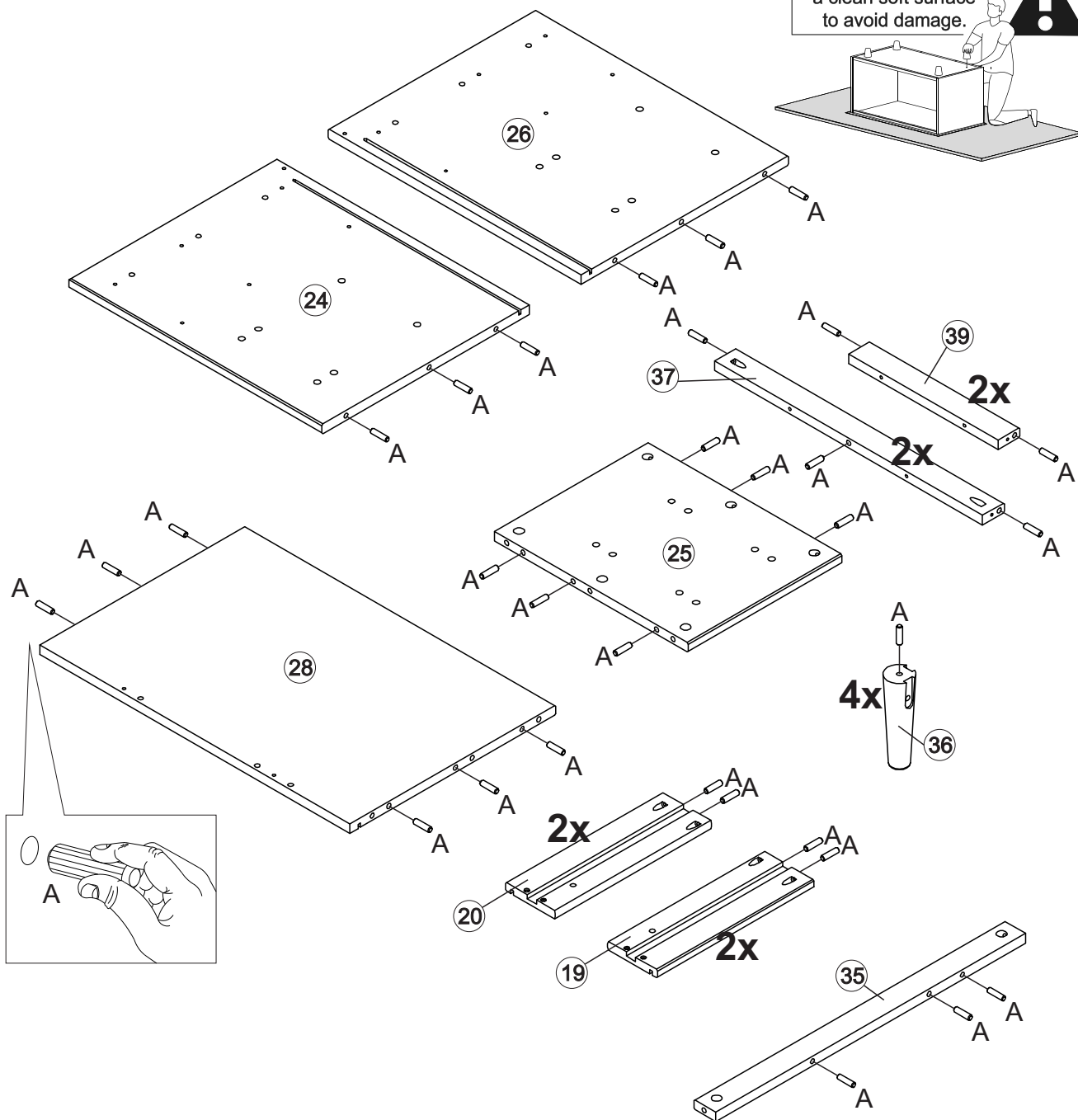

Insert wood dowel (A) into parts 19, 20, 24, 25, 26, 28, 35, 36,
37 and 39.

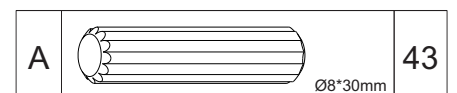

Step 3

1 - Ensure cam bolt is installed straight and not at an angle.
2 - Tighten cam bolt until shoulder on cam bolt is flush. Do not over-tighten.

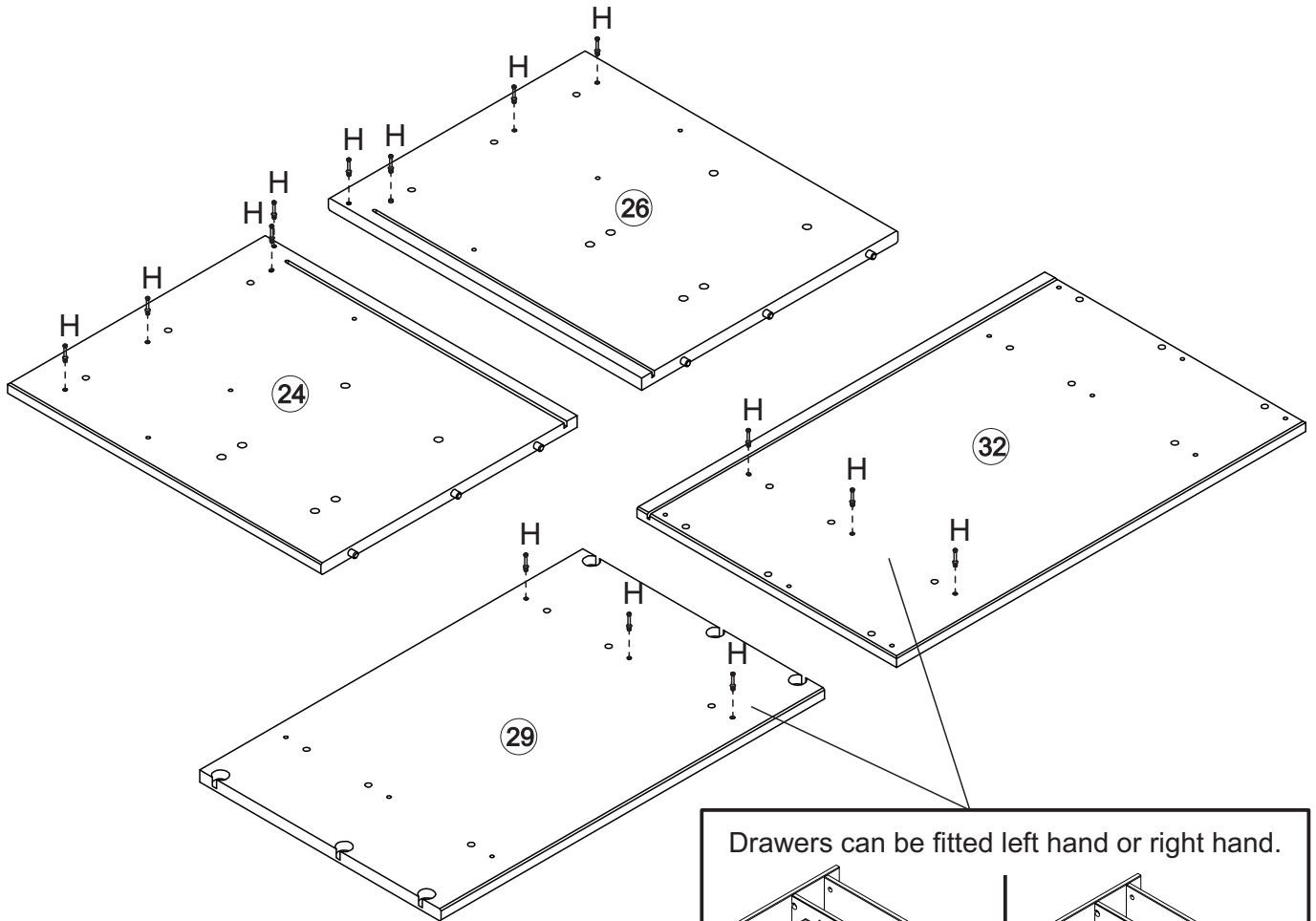
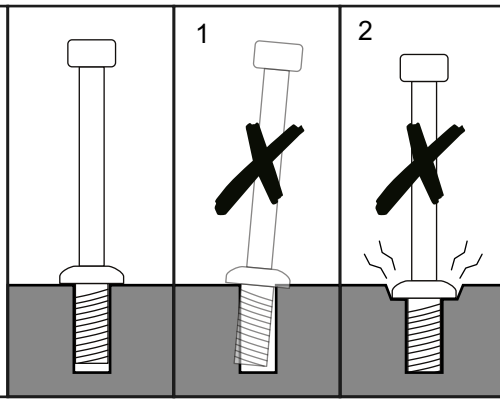

Drawers can be fitted left hand or right hand.

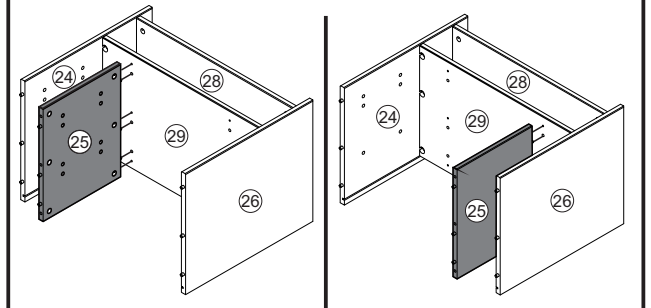

WARNING!

Assembly instruction shows drawers in the right side

Fix the Cam bolt (H) in part 24, 26, 29 and 32 using a Phillips head screwdriver.

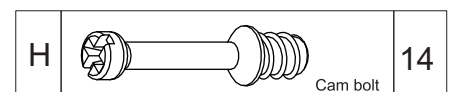

Step 4

1 - Ensure cam bolt is installed straight and not at an angle.
 2 - Tighten cam bolt until shoulder on cam bolt is flush. Do not over-tighten.

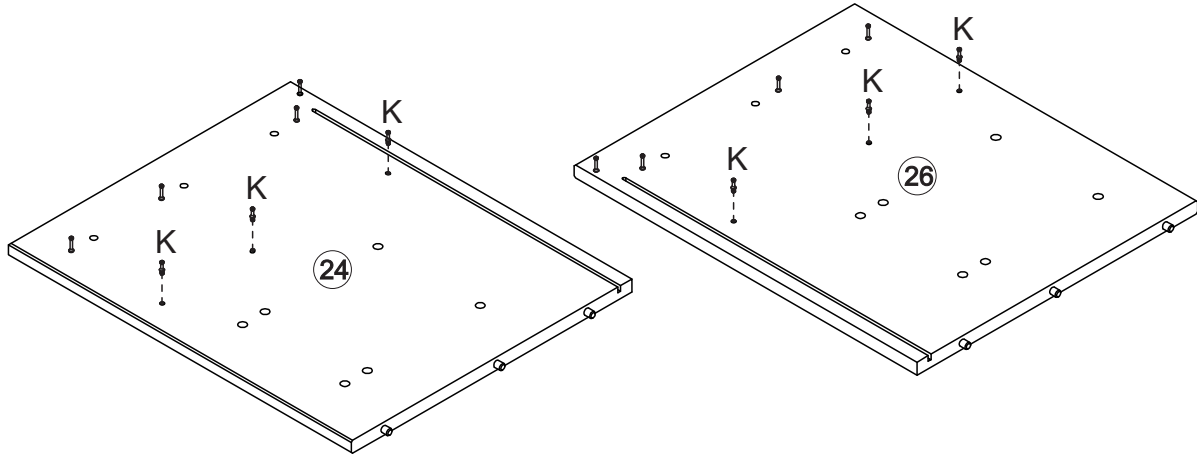
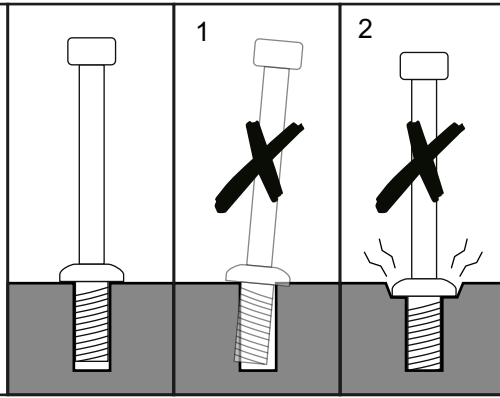

Fix the Cam bolt (K) in part 24 and 26 using Phillips head screwdriver.

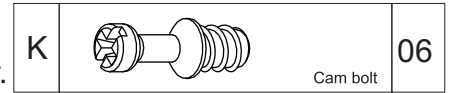

Step 5

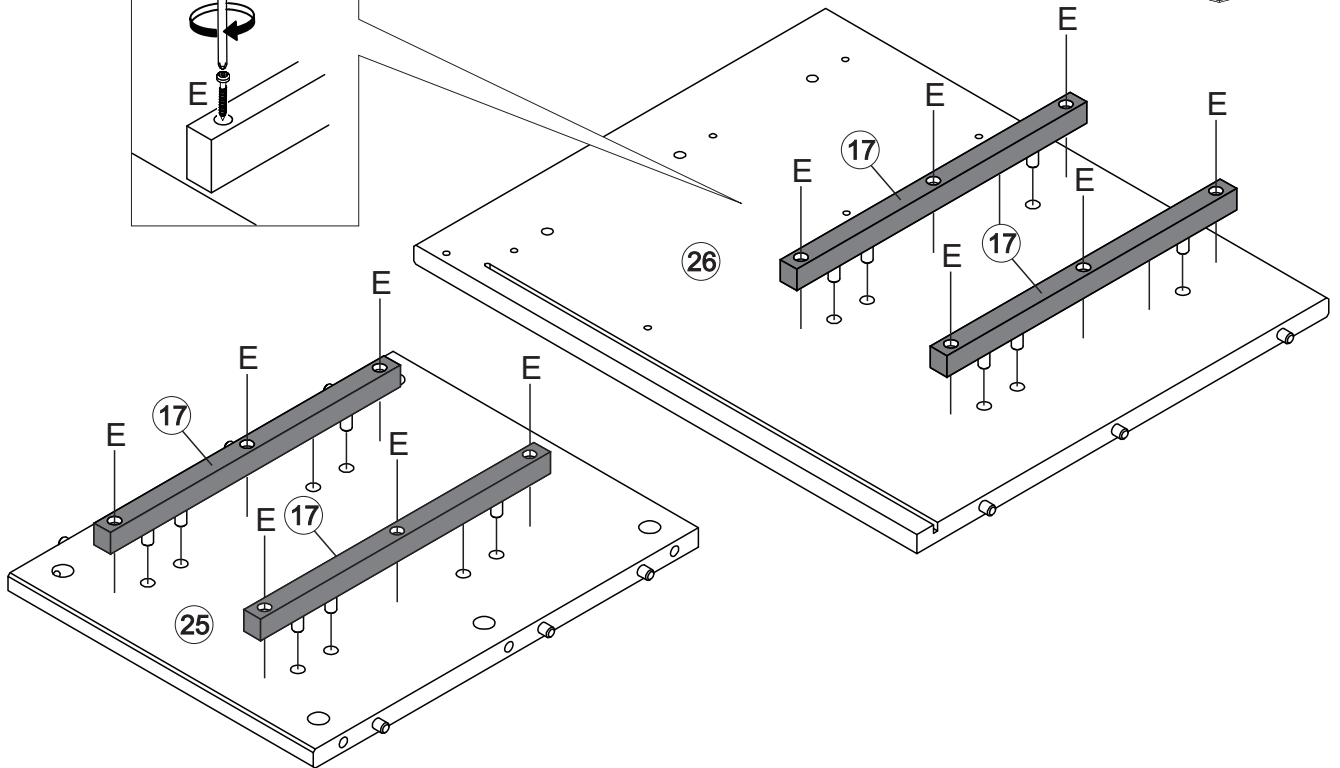
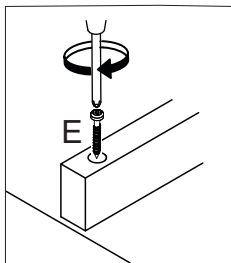

Secure part 17 to part 25 and 26 with screw (E) using a Phillips head screwdriver.

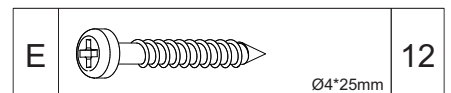

Step 6

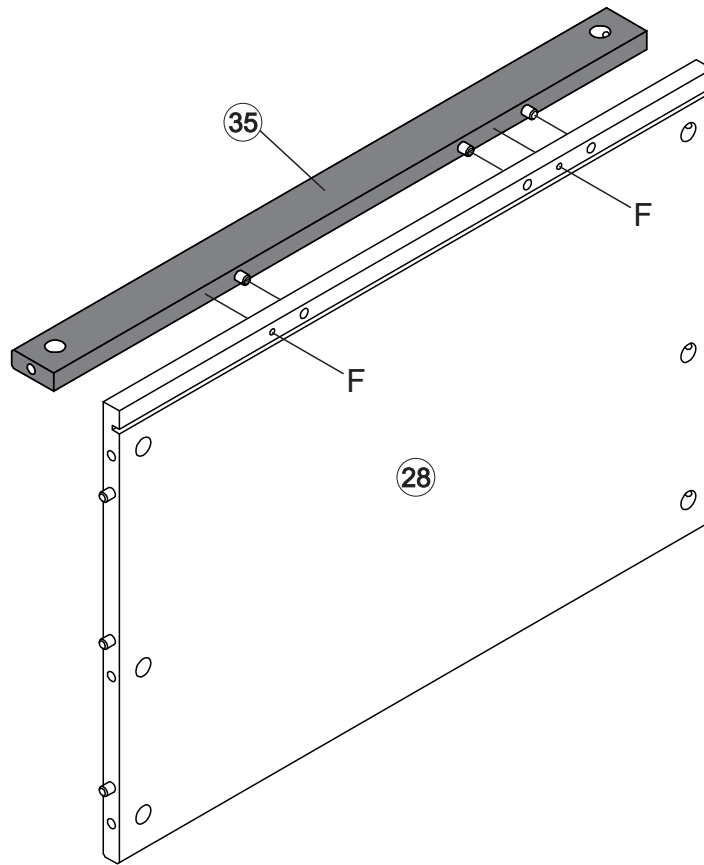

Secure part 35 to part 28 with screw (F) using a Phillips head screwdriver.

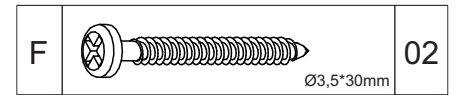

Step 7

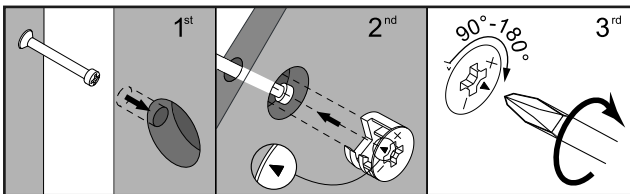

Align the opening in cam lock to the cam bolt and press into opening. Using a screwdriver, rotate the cam lock until it engages with the cam bolt and locks in place (anywhere between 90-180 degrees). Do not over-tighten the cam lock. Doing so may result in damaged or broken parts.

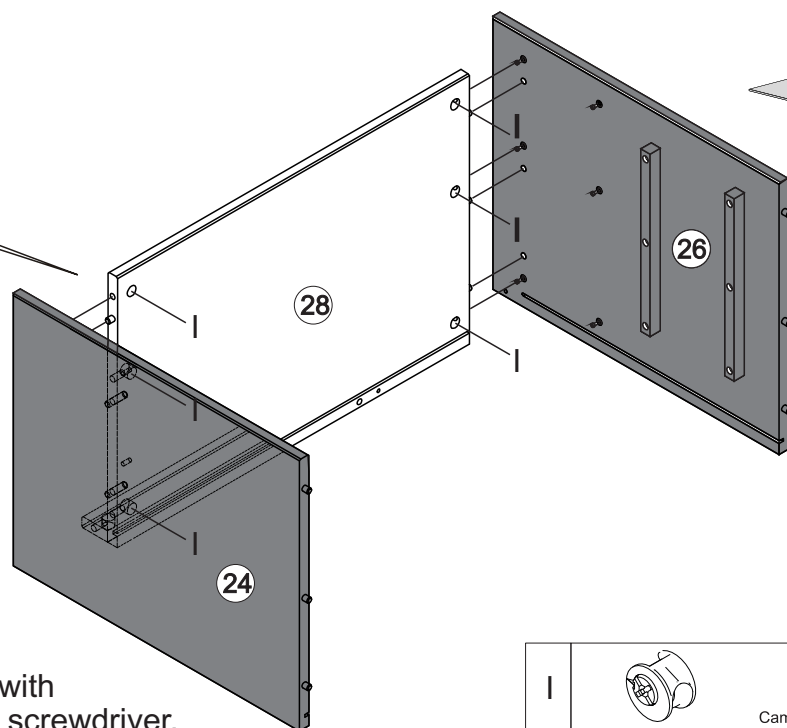
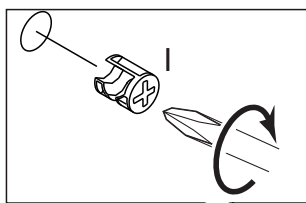

Secure part 24 and 26 to part 28 with cam lock (I) using a Phillips head screwdriver.

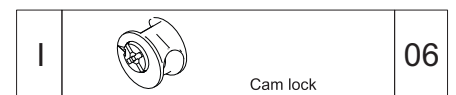

Step 8

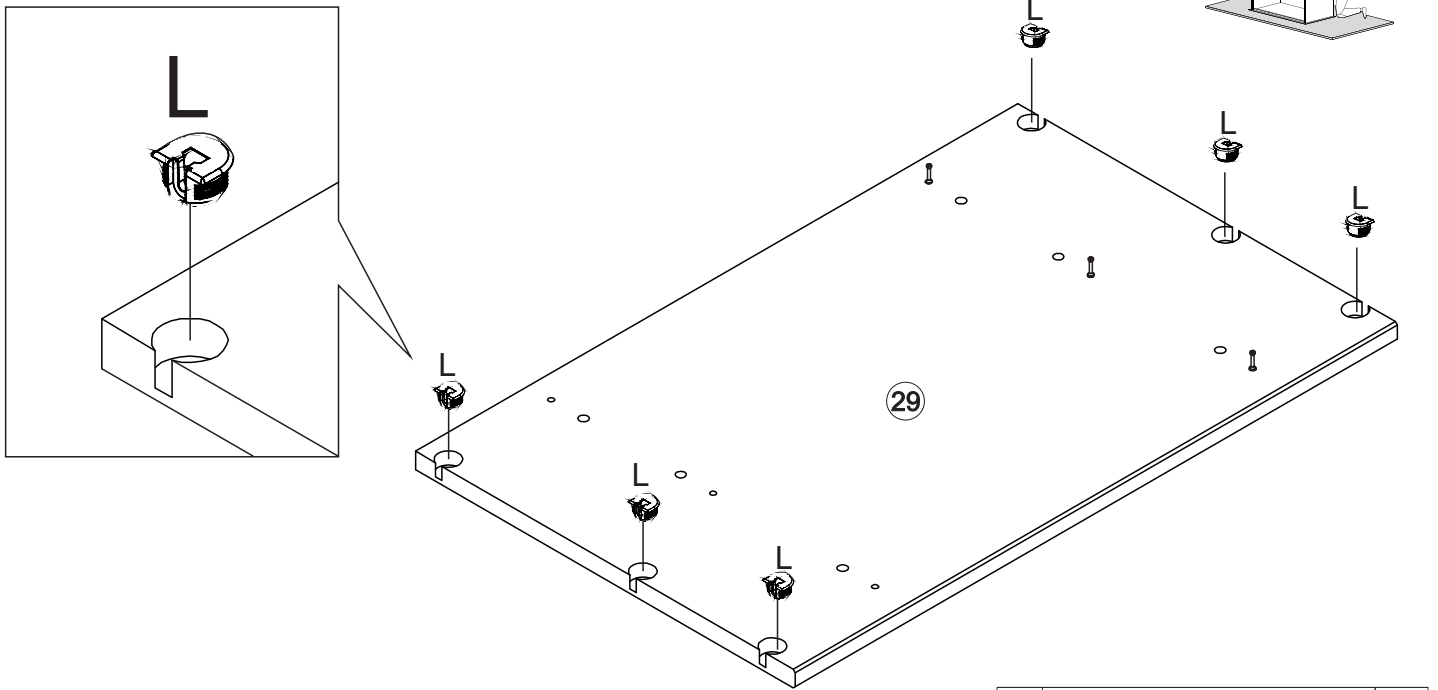

Insert plastic lock (L) into part 29 using a hammer.

L		06
---	---	----

Step 9

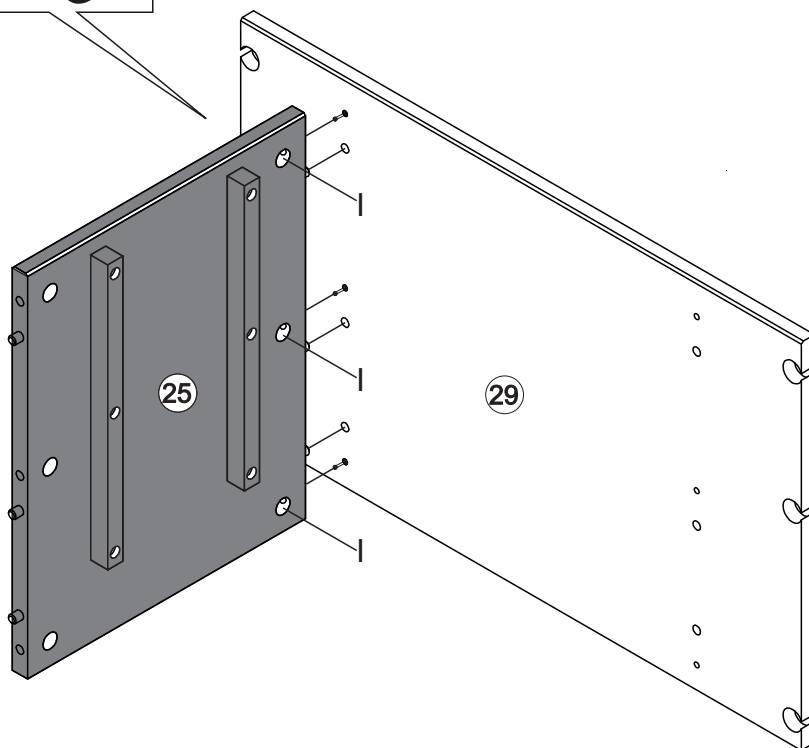
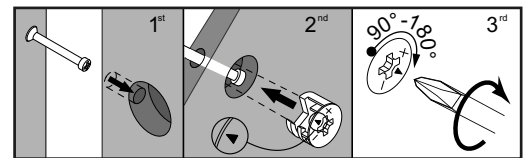
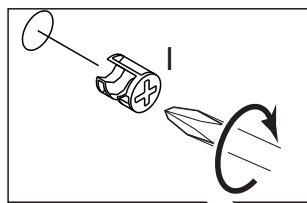

Secure part 25 to part 29 with Cam lock (I) using a Phillips head screwdriver.

I		Cam lock	03
---	---	----------	----

Step 10

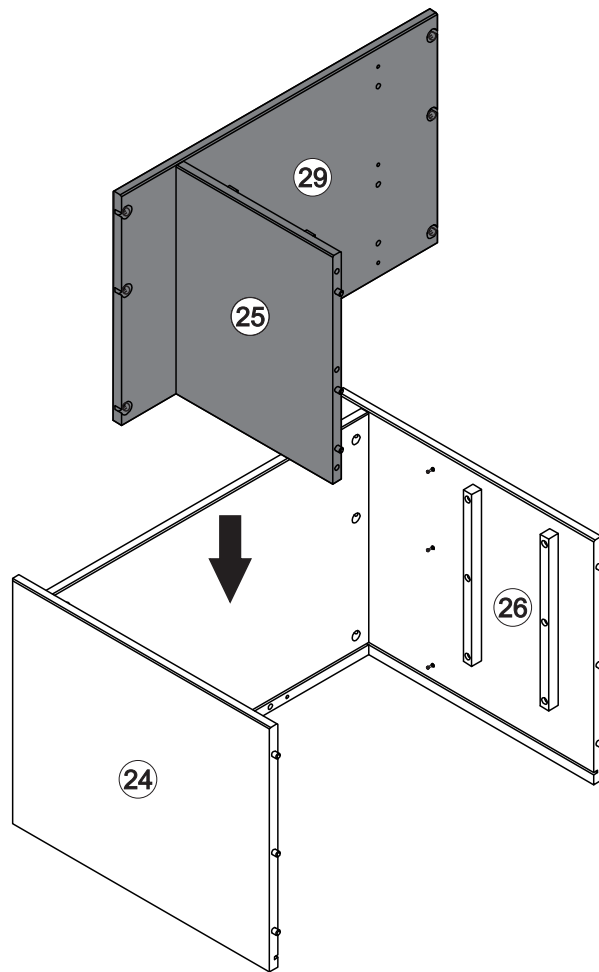

Insert pieces 25 and 29 over the pins. Align and fit the pins inside the hardware (L).

Step 11

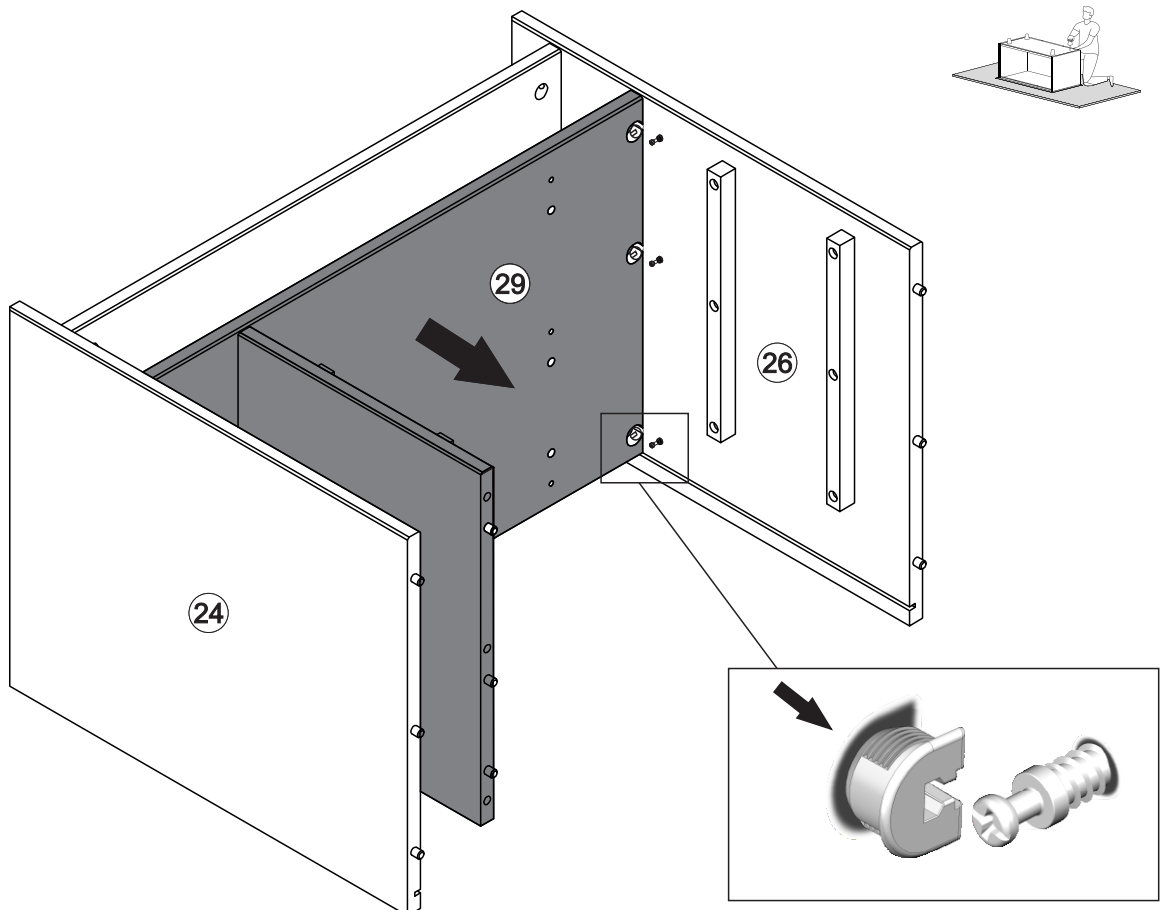

Press until you feel the fit or "click".

Step 12

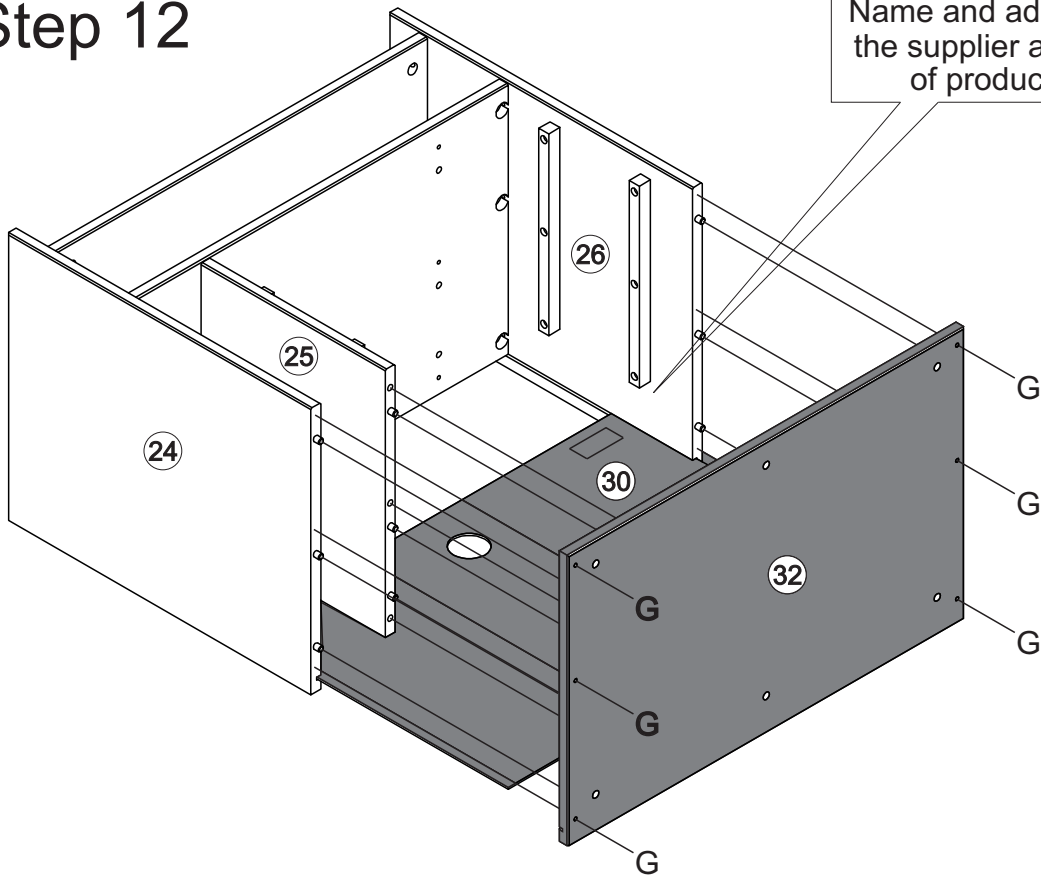

Name and address of the supplier and date of production.



Insert part 30 to body. Attach part 32 to part 24 and 26 with screw (G) using a Phillips head screwdriver.

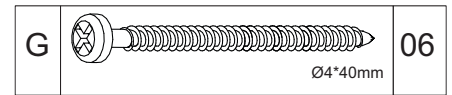

Step 13

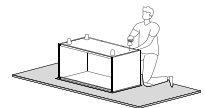
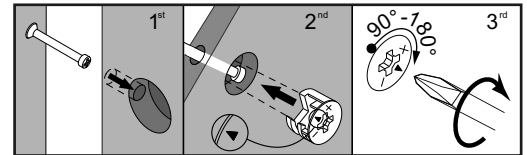
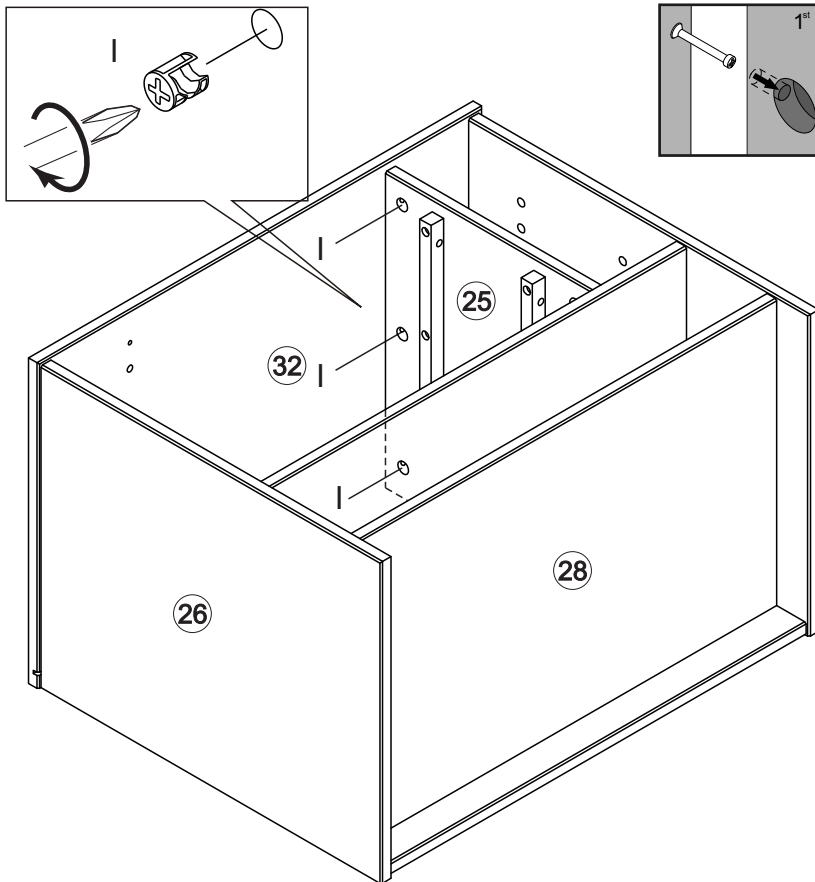

Secure part 32 to part 25 with Cam lock (I) using a Phillips head screwdriver.

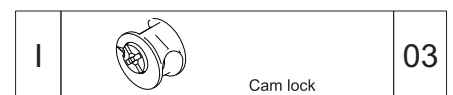

Step 14

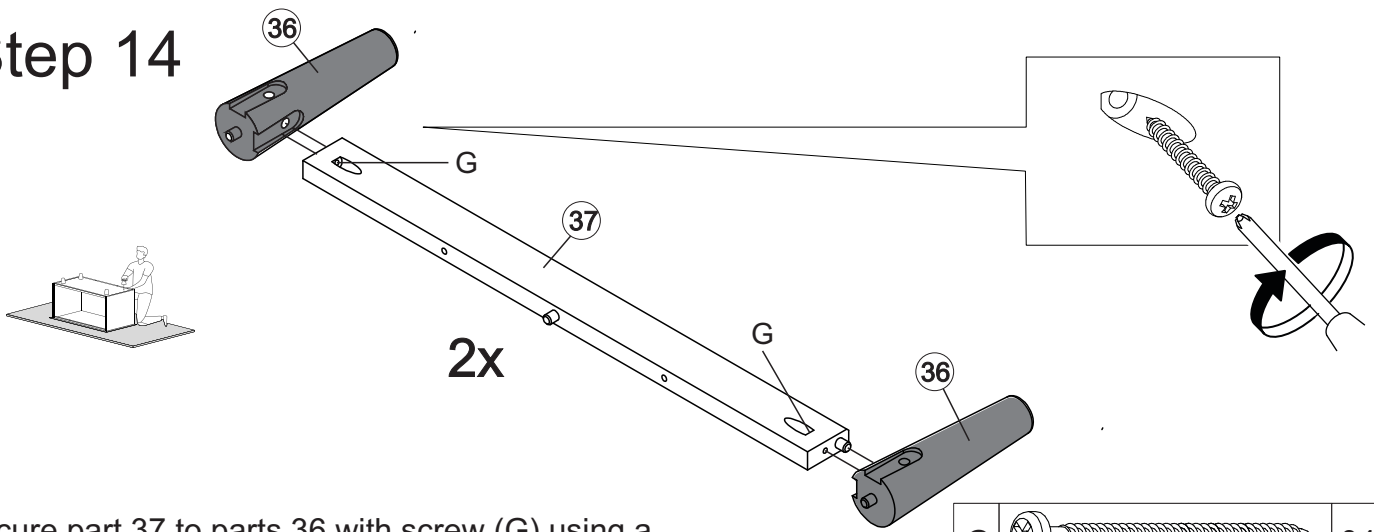

Secure part 37 to parts 36 with screw (G) using a Phillips head screwdriver.

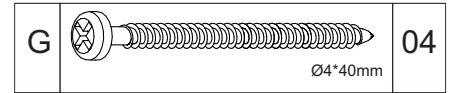

Step 15

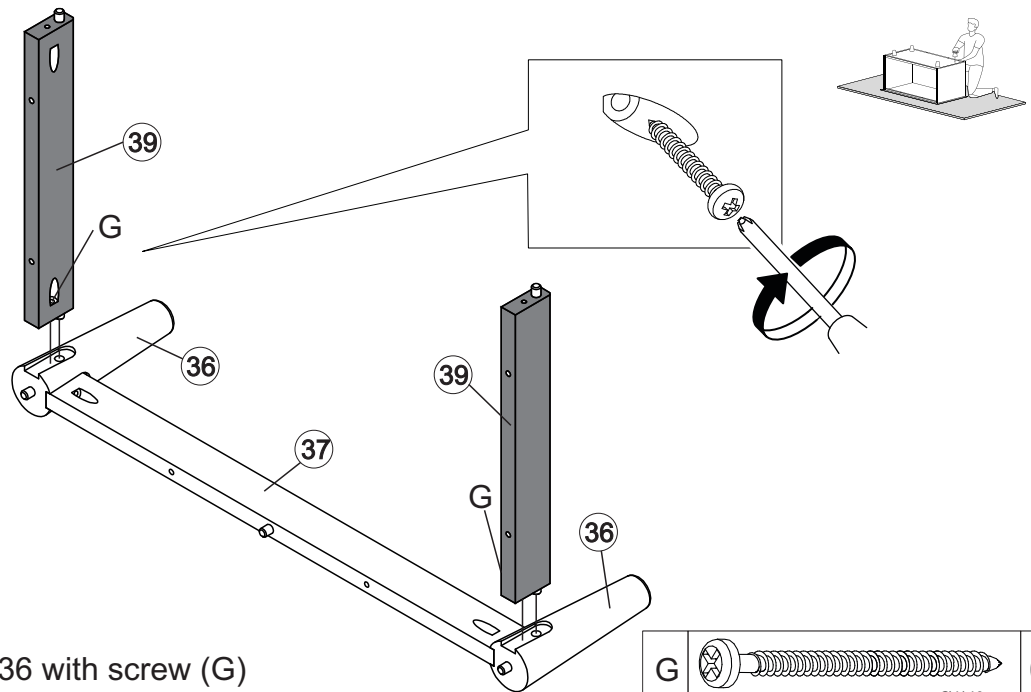

Secure parts 39 to parts 36 with screw (G) using a Phillips head screwdriver.

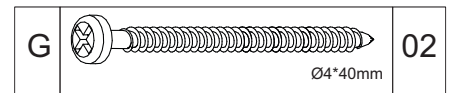

Step 16

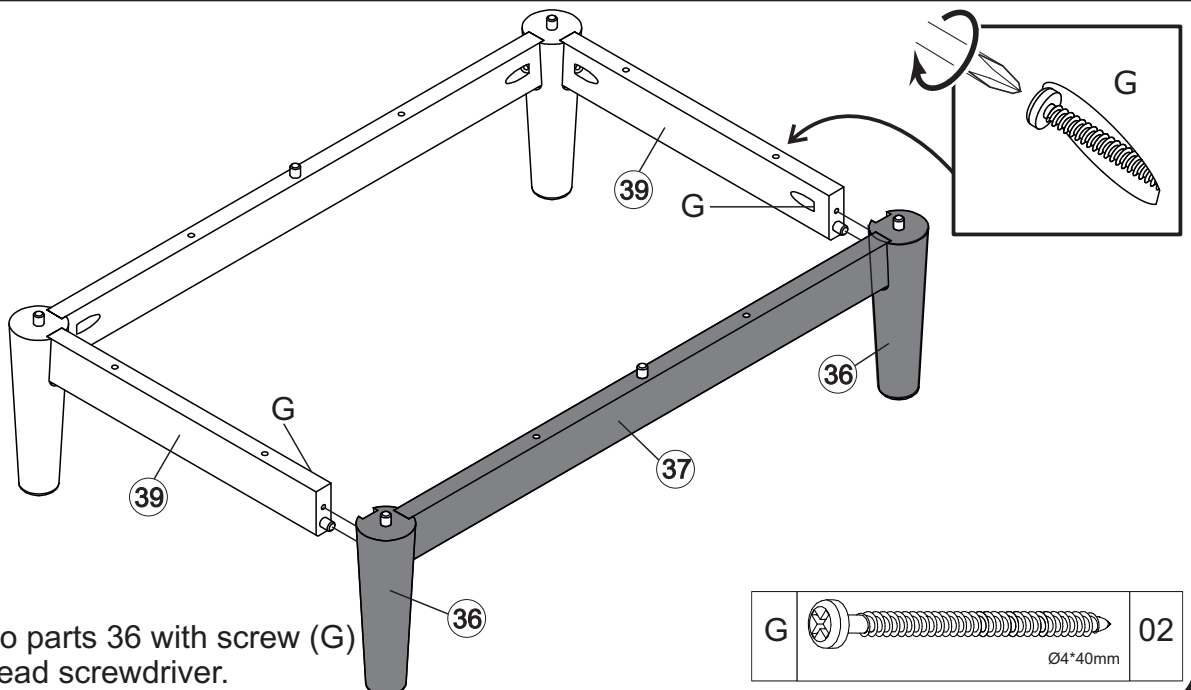

Secure parts 39 to parts 36 with screw (G) using a Phillips head screwdriver.

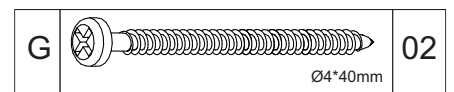

Step 17

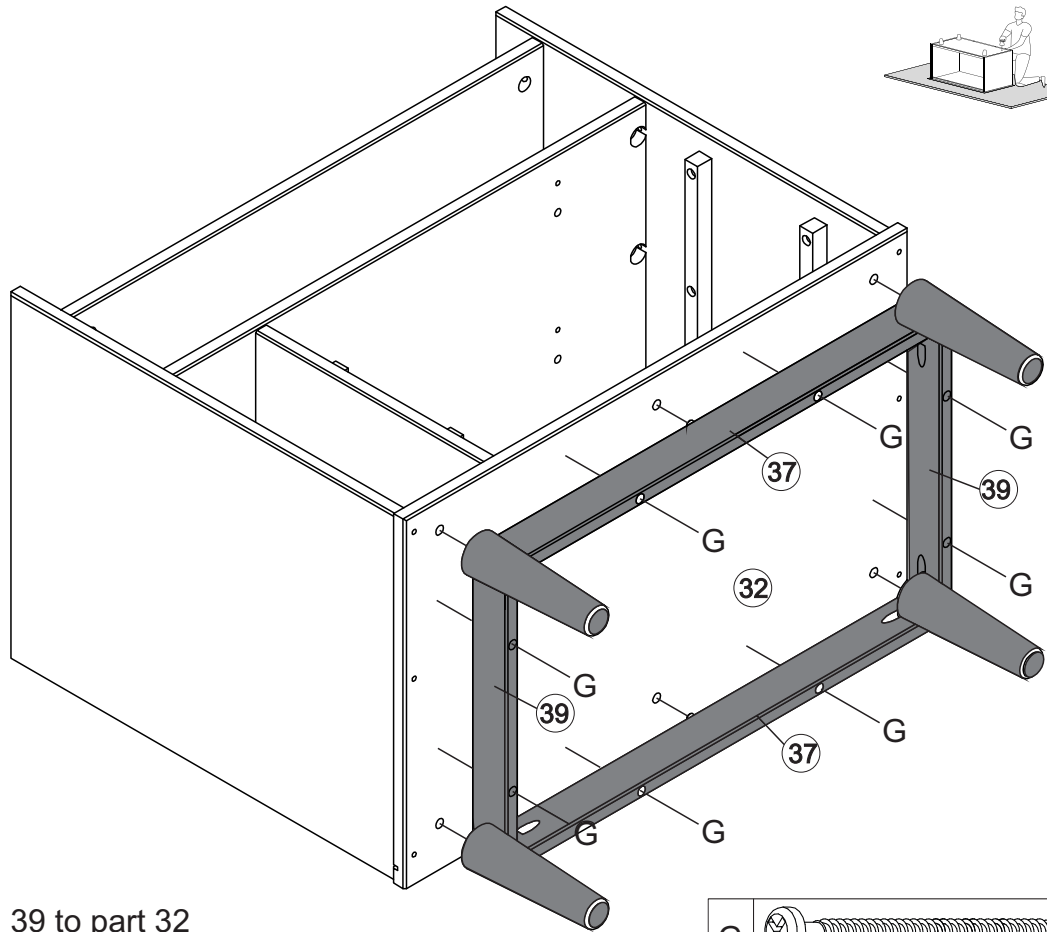

Secure parts 37 and 39 to part 32 with screw (G) using a Phillips head screwdriver.

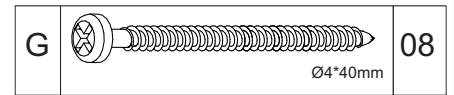

Step 18

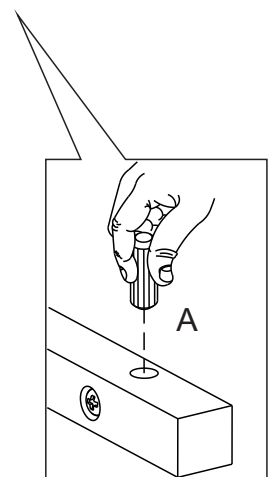
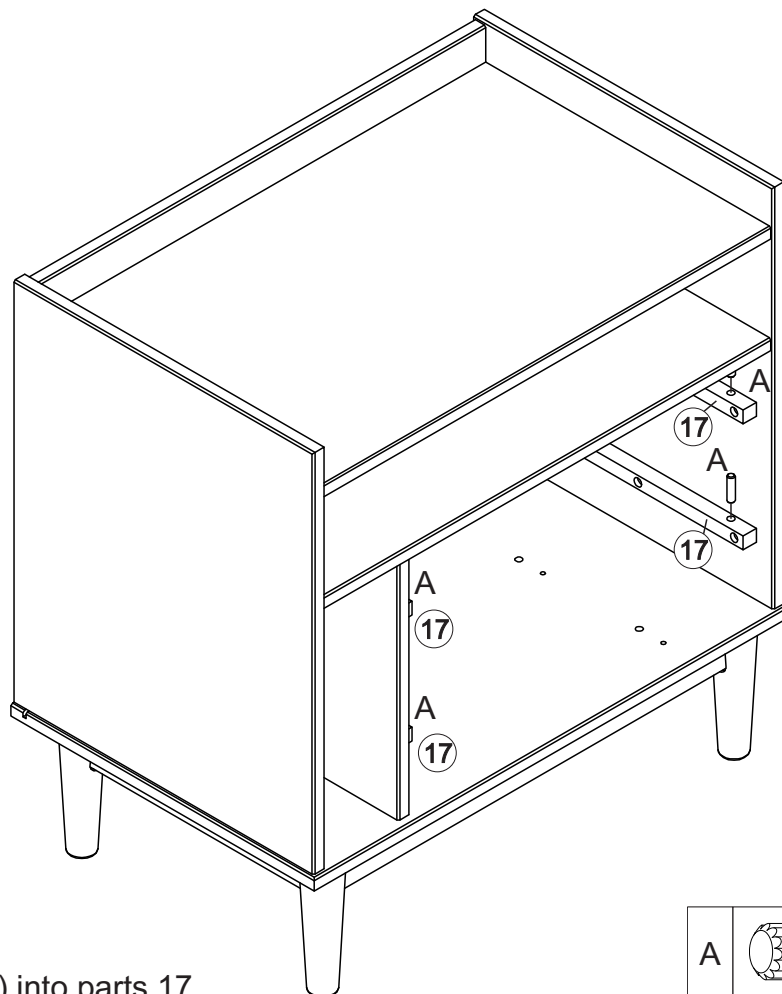

Insert wood dowel (A) into parts 17.

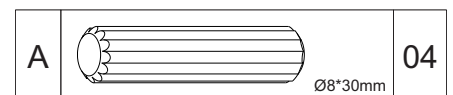

Step 19

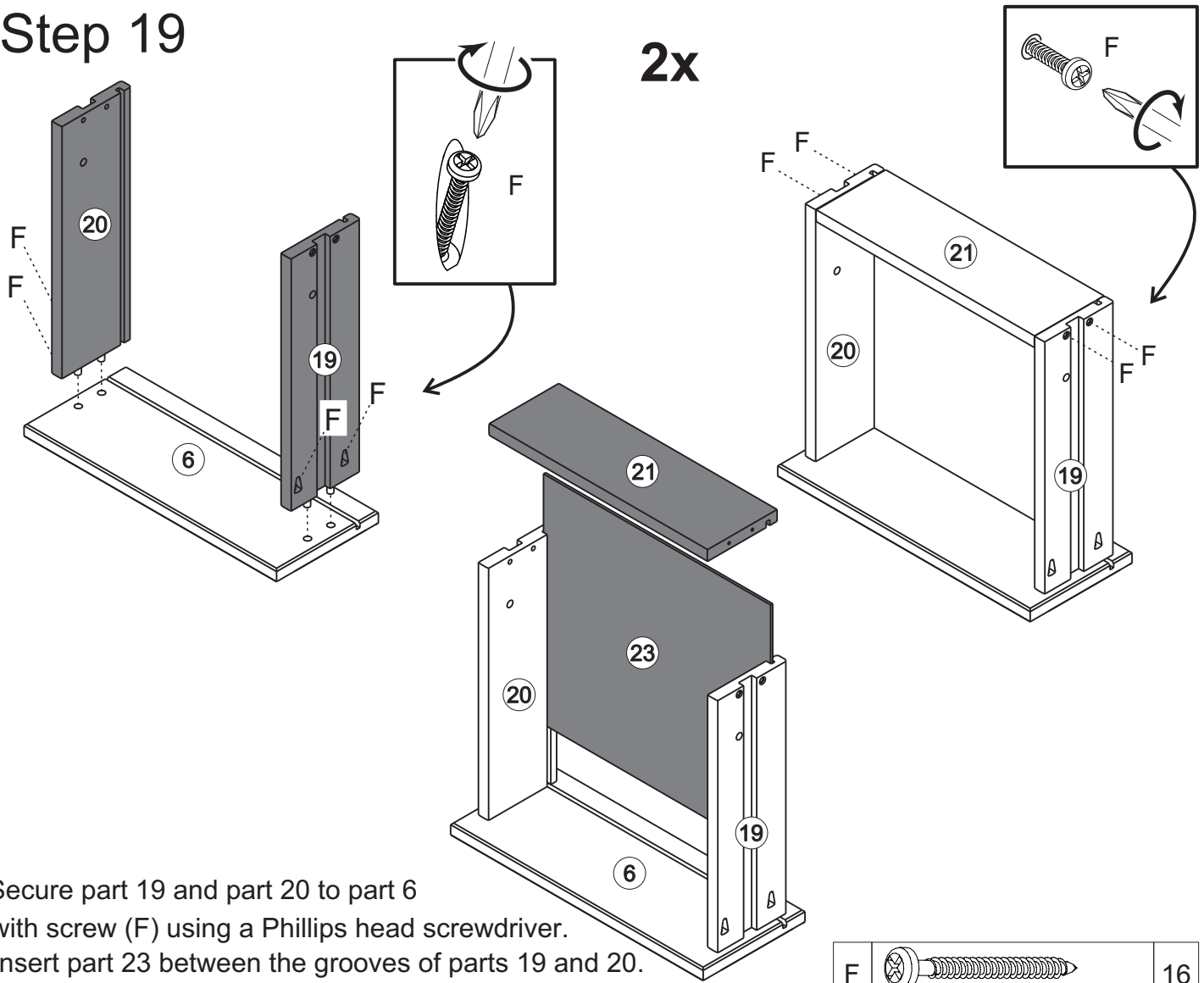

Secure part 19 and part 20 to part 6 with screw (F) using a Phillips head screwdriver.
 Insert part 23 between the grooves of parts 19 and 20.
 Secure part 21 with screw (F) using a Phillips head screwdriver.

F		16
		Ø3,5*30mm

Step 20

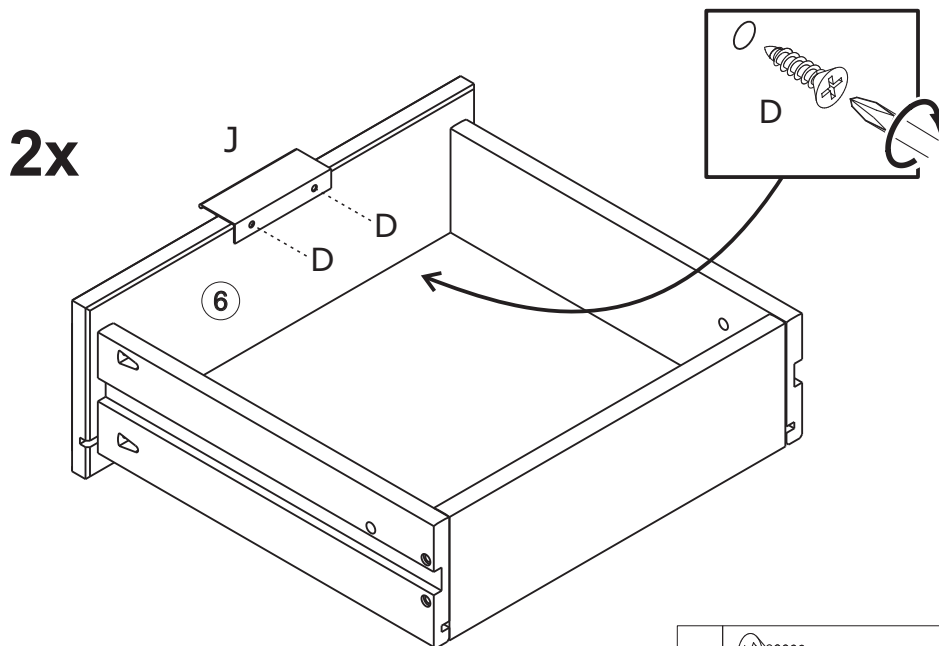

Secure handle (J) with screw (D) using a Phillips head screwdriver in the pre holes on the drawer front.

D		04
		Ø3,0*12mm
J		02

Step 21

Drawer Stop

Insert wood dowel (B) on the inside of all drawers, with the drawer inside the unit, after having passed the wood dowel that is in the drawer slide. The dowel is not flush with the panel, it is a little inside the drawer to help when you need to remove the lock dowel to remove the drawer.

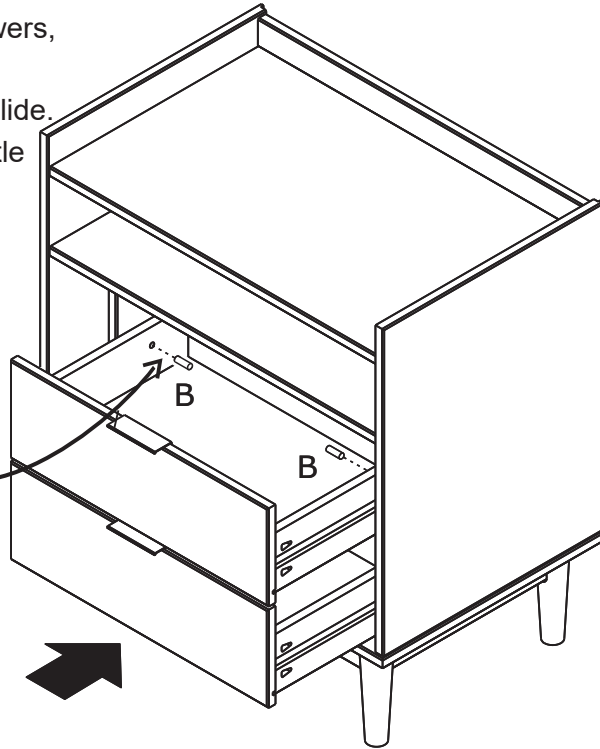
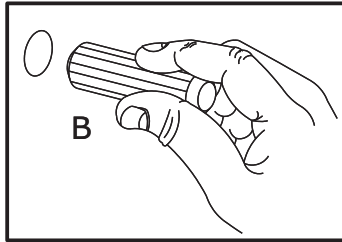

Step 22

There are colors options for the slaps, choose the slap according to the color of your item.

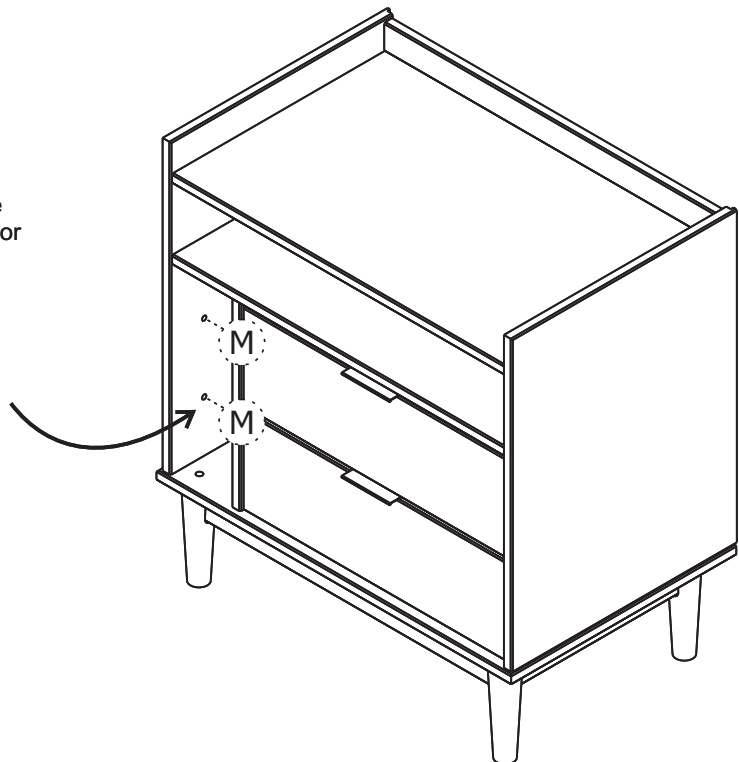
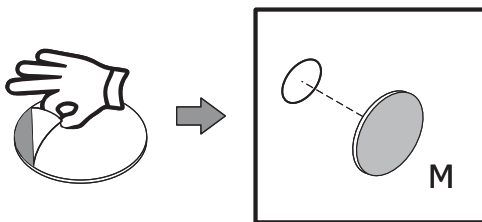

Insert the slap hole (M) into the niche.



Step 23

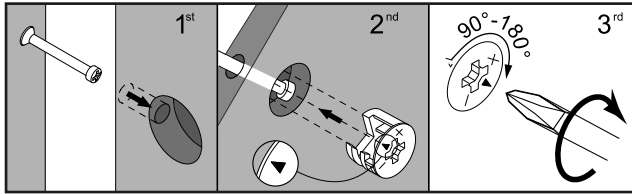

Align the opening in cam lock to the cam bolt and press into opening. Using a screwdriver, rotate the cam lock until it engages with the cam bolt and locks in place (anywhere between 90-180 degrees). Do not over-tighten the cam lock. Doing so may result in damaged or broken parts.

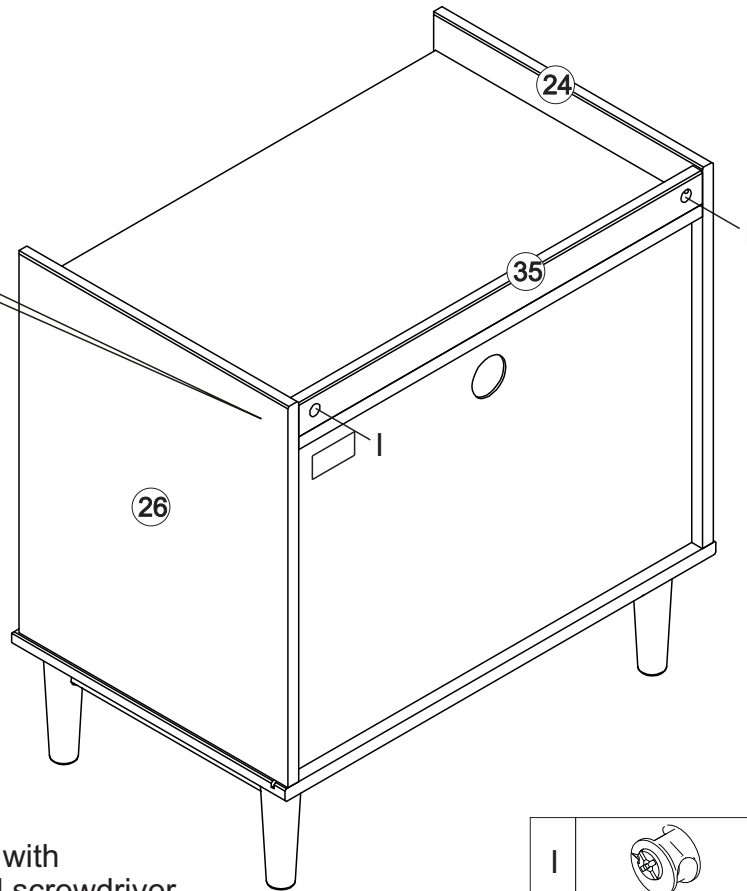
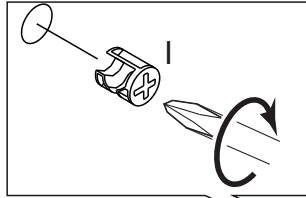

Secure part 35 to part 24 and 26 with cam lock (I) using a Phillips head screwdriver.

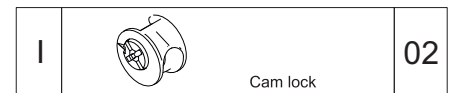

Step 24

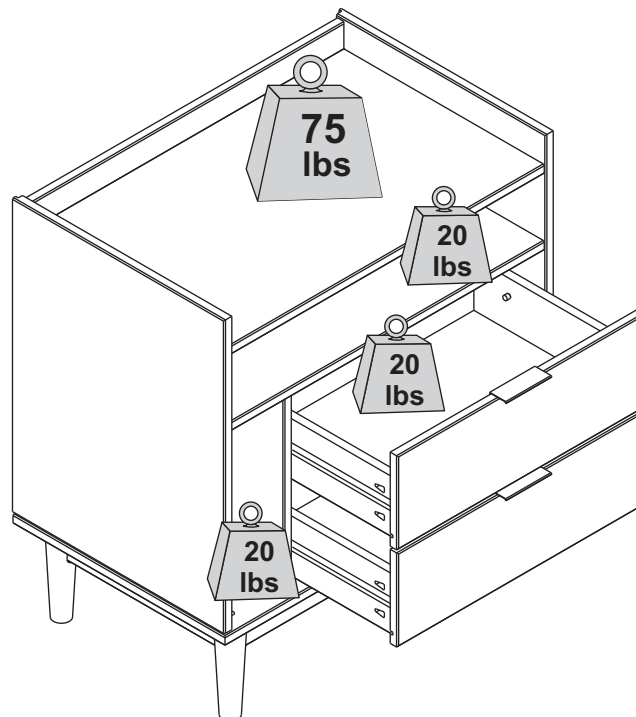

Assembly Complete!