

**WALKER EDISON**  
™

Elias Modern Curved-  
Frame Solid Wood  
Nightstand

SKU: ELIB4C  
LOT: **AAYYWW-XXX**

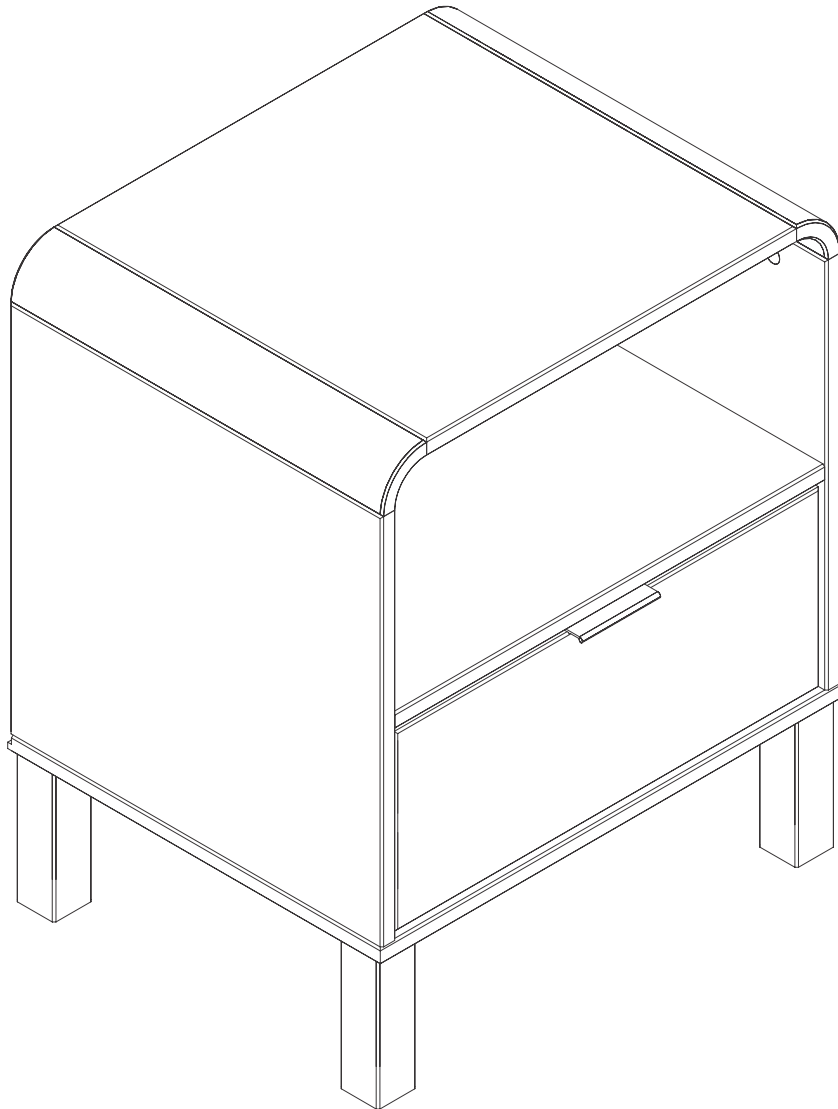

*For Residential Use Only*

Please visit our website for the most current instructions, assembly tips, to report damage, or request parts. [www.walkeredison.com](http://www.walkeredison.com)

# WE Time to get started

Set up a clean and soft workplace to avoid damage during assembly. You can use the box and internal protections as a cover. It also helps to double-check if you have got all the pieces and parts before diving into the assembly.

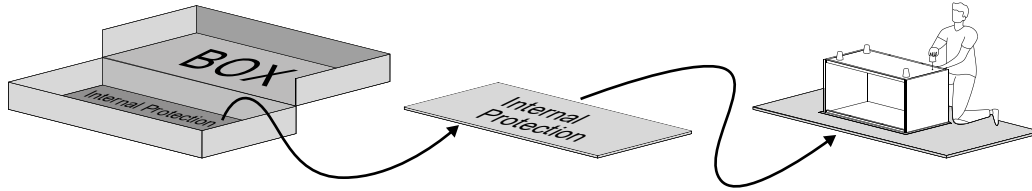

**Estimated time  
for assembly**

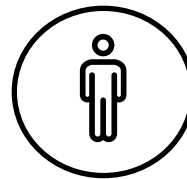

1 Person Build

**You can assemble  
it alone.**

But you can make  
it a team effort!  
Grab a friend for quicker,  
easier assembly.

## Tools Needed

Grab a Phillips head screwdriver to  
conquer this assembly.

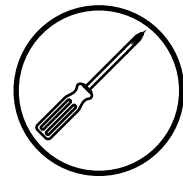

## Use power tools with caution

This furniture is made of Solid Wood and Composite Wood, soft materials. If you choose to use power tools, set it to the slower setting. Be careful! Power tools can cause cracking or damage to the furniture, they can also damage the hardware if misused. Power tool damages are not covered by the Walker Edison warranty

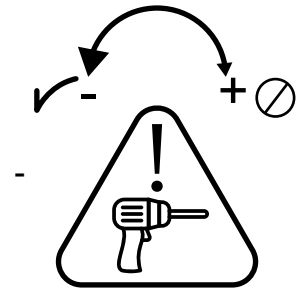

**Scan to get assembly tips and help!**

# WE Part List

Part Number	Description	Quantity
07	Back panel	01
24	Bottom panel	01
25	Shelf	01
26	Foot	04
27	Drawer bottom	01
29	Left drawer side	01
30	Right drawer side	01
42	Right side panel	01
43	Left side panel	01
44	Drawer front	01
45	Top panel	01
46	Drawer back	01

**WALKER EDISON**  
 Distribution By:  
 Walker Edison Furniture Company  
 1553 W 9000 S, West Jordan,  
 UT 84088 United States

**ELIAS**  







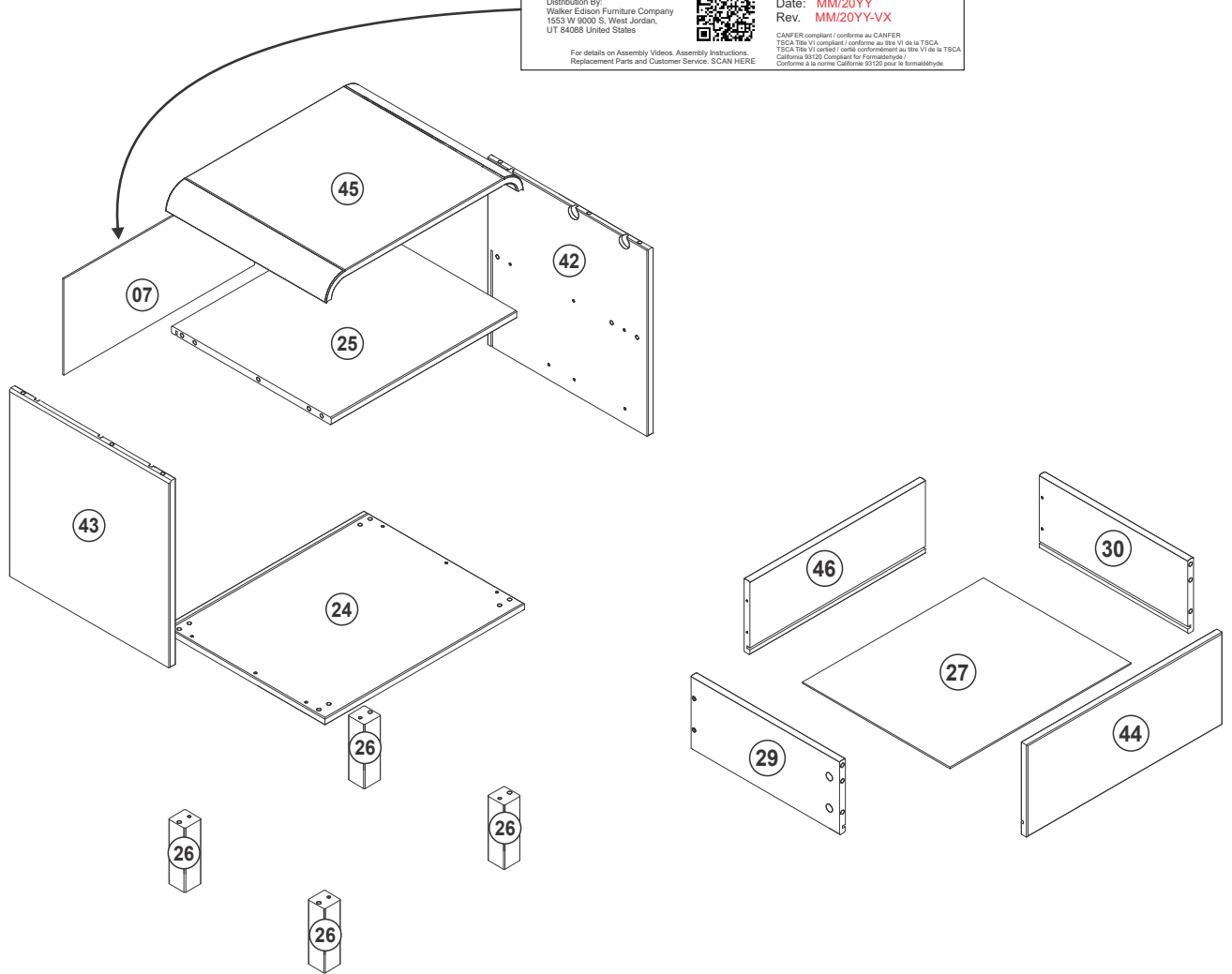

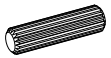
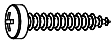
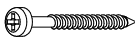

Model: XXXXXXXXFF  
 LOT: AAYYWW-XXX  
 Date: MM/20YY  
 Rev: MM/20YY-VX

CANFER compliant / conforme au CANFER  
 TSCA Title VI compliant / conforme au titre VI de la TSCA  
 TSCA Title VI certified / certifié conformément au titre VI de la TSCA  
 California 93120 Compliant for Formaldehyde / Conforme à la norme Californie 93120 pour le formaldéhyde.

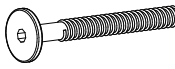
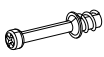
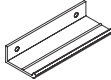
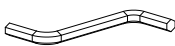
For details on Assembly Videos, Assembly Instructions,  
 Replacement Parts and Customer Service: SCAN HERE

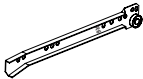
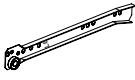

# WE Hardware List

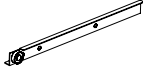
Part	Size	Name	Quantity
A	 8x30mm	Wooden dowel	22
B	 3,5x20mm	Screw	06
C	 3,5x30mm	Screw	04
D	 4x40mm	Screw	06
E	 15x12mm	Cam lock	10
F	 6x8mm	Screw	06
G	 3,5x14mm	Screw	08
H	 7x80mm	Bolt	04
I	 5x24mm	Cam bolt	10
J		Handle	01
K		Hex key	01
L	 26mm	Plastic fixing device	06
M	 33mm	Cover	06
N	 30mm	Felt sticker	04
O	 250mm	Right Drawer slide support (R6)	01
P	 250mm	Left Drawer slide support (L6)	01
Q	 250mm	Right Drawer slide	01
R	 250mm	Left Drawer slide	01

The hardware quantities listed above are required for proper assembly.  
Extra hardware pieces may be included.



# Step 1

Let's start! Insert the Wooden dowel (A) into Shelf (25), Foot (26), Left Drawer Side (29), Right Drawer Side (30), Right Side Panel (42) and Left Side Panel (43).

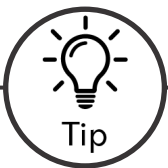
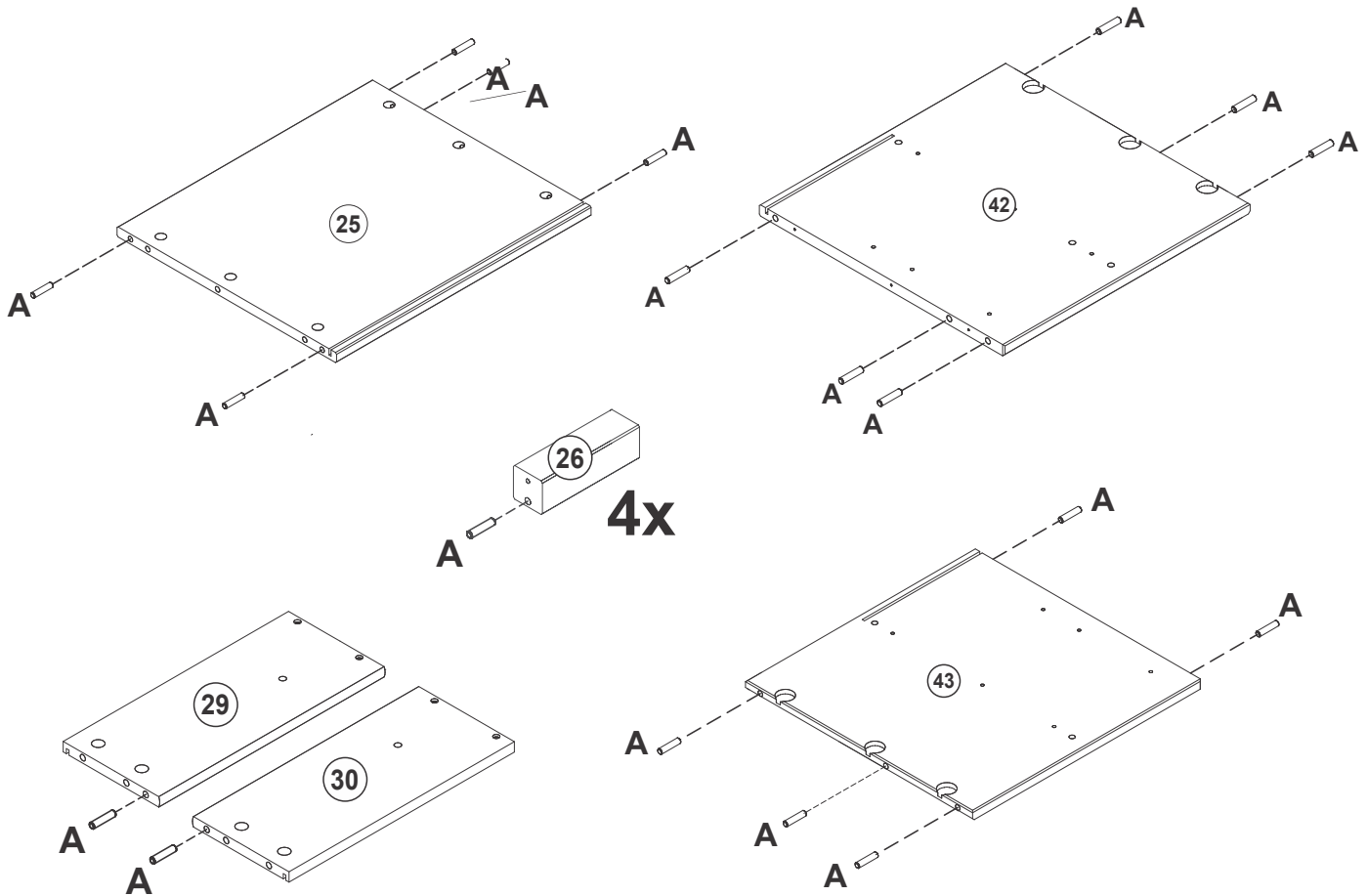
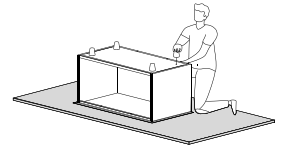

Tip

## Wood Dowels

Dowels are essential in furniture assembly to create strong, precise connections.

They ensure structural integrity, prevent shifting, and simplify alignment, resulting in sturdier, longer-lasting furniture.

Follow these steps:

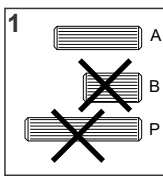

1: Select the appropriate size dowel according with step.

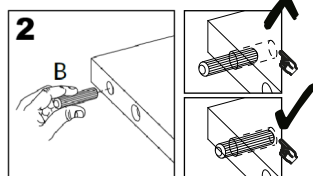

2: Insert into drilled hole and press firmly to ensure placement is set.

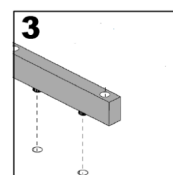

3: Align the dowel with corresponding piece and press together until secure.

# Step 2

Insert Cam Bolts (I) using a Phillips head screwdriver into Right Side Panel (42), Left Side Panel (43) and Drawer Front (44).

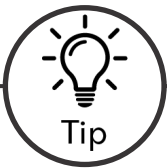
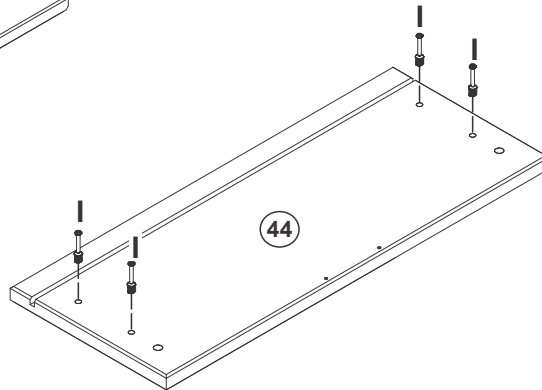
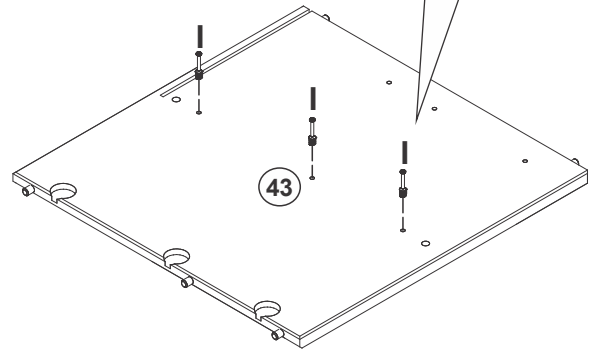
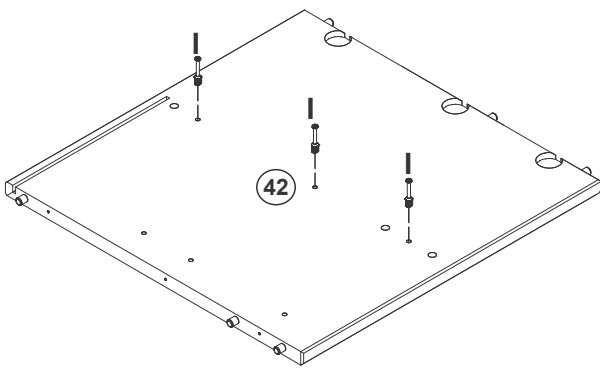
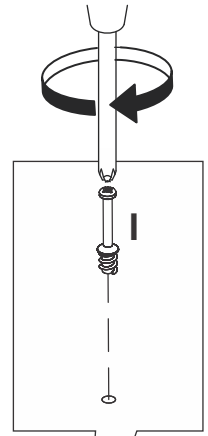
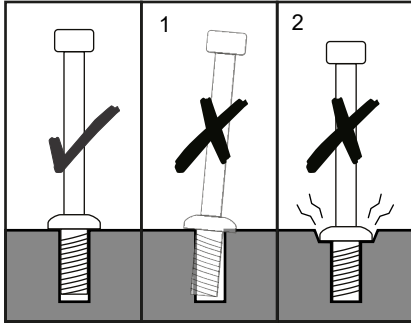

To keep your product looking its best and scratch-free, try assembling it on a soft surface like carpet or a blanket. This helps prevent any accidental scratches and keeps your furniture in top shape!

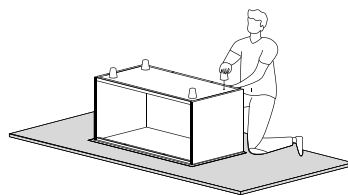

# Step 3

Insert Plastic fixing device (L) into Right Side Panel (42) and the Left Side Panel (43).

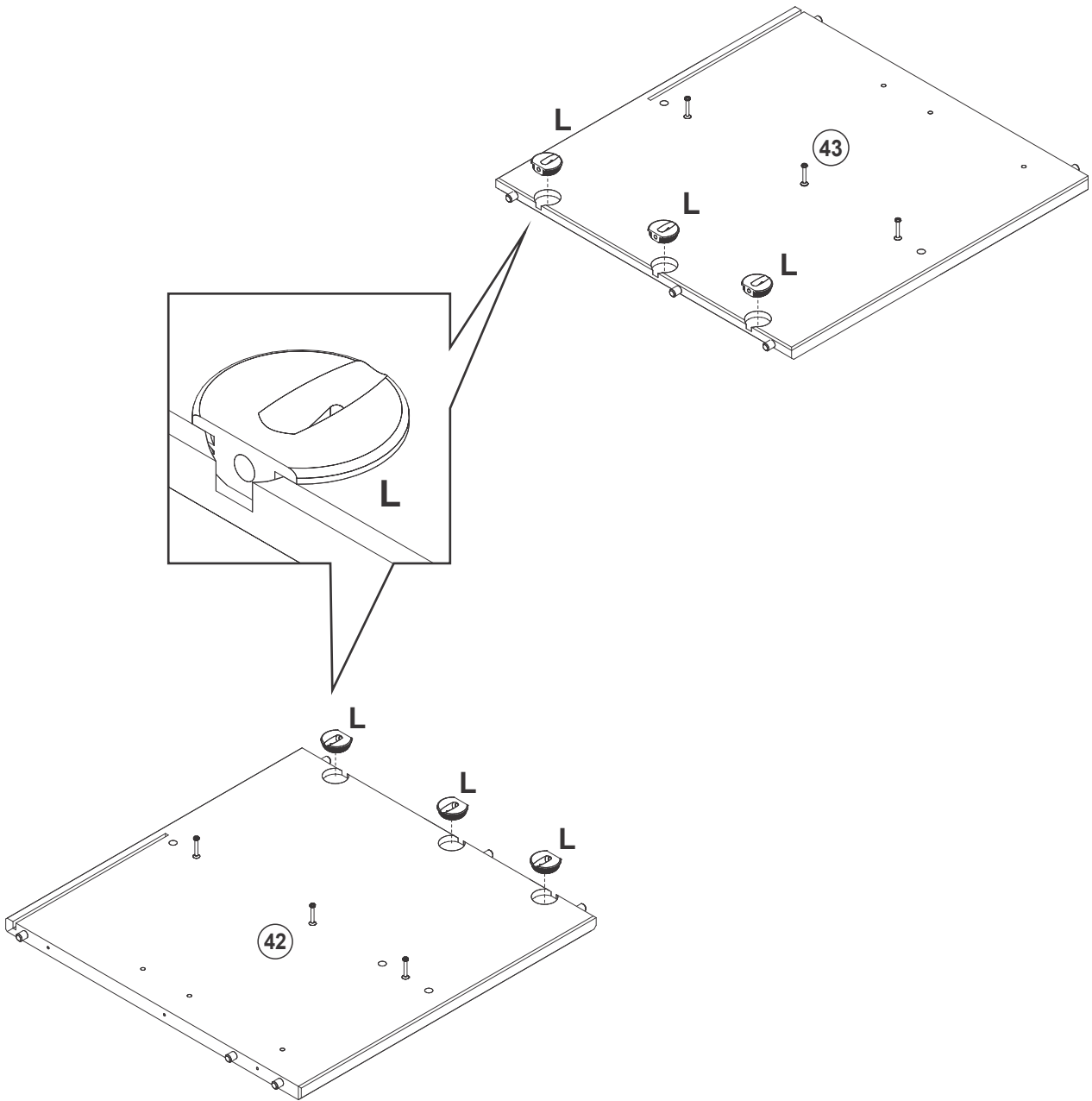
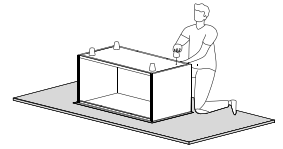

# Step 4

Secure Right drawer slide support (O) to Right Side Panel (42) using Screw (F) and a Phillips head screwdriver.

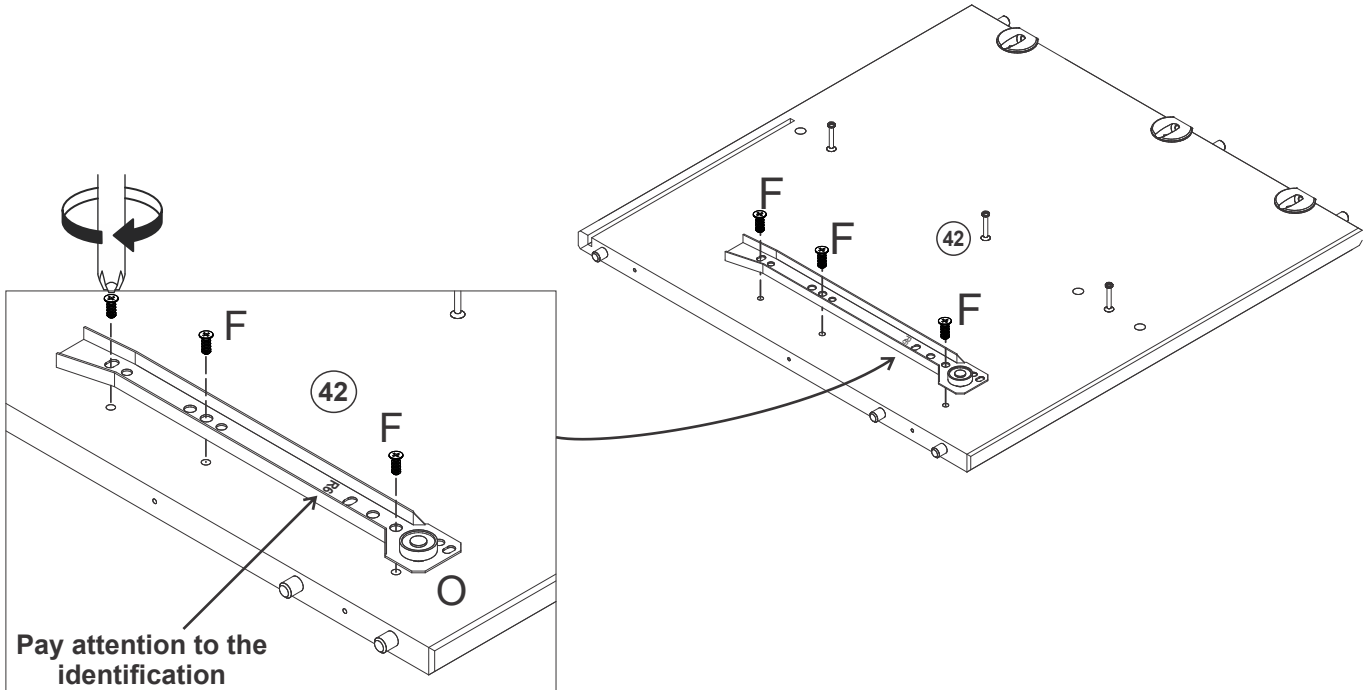
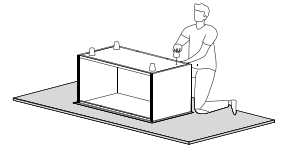

Secure Left drawer slide support (P) to the Left Side Panel (43) with screw (F) and phillips head screwdriver.

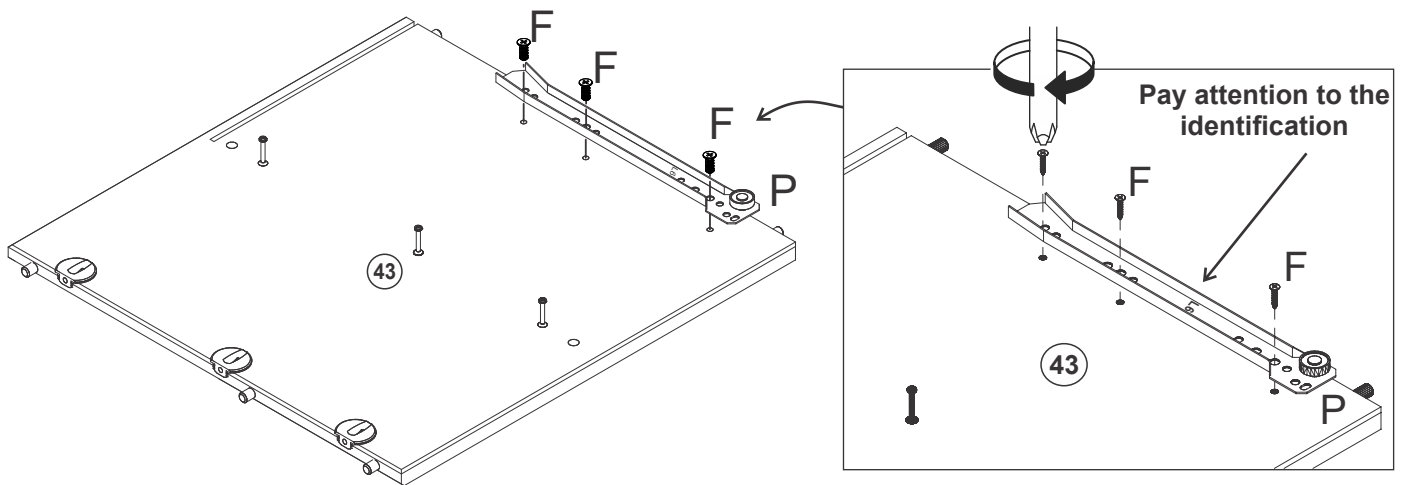

# Step 5

Use a phillips screwdriver to fix Screw (G) and secure the Right drawer slide support (O) and Left drawer slide support (P).

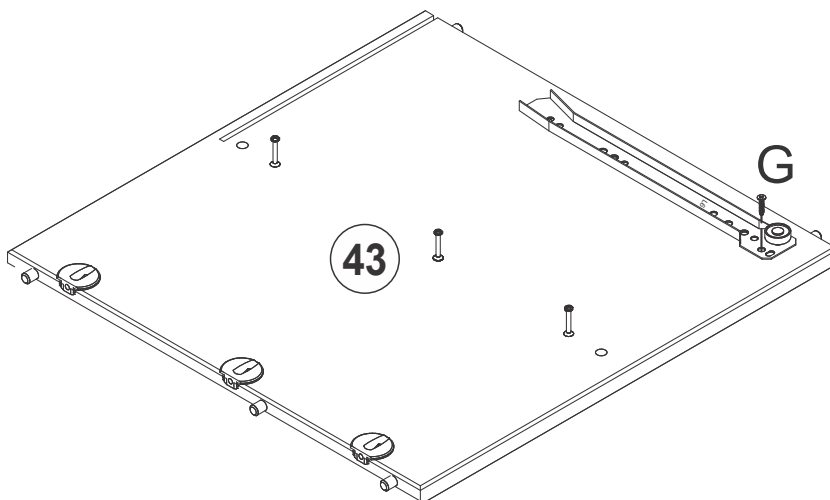
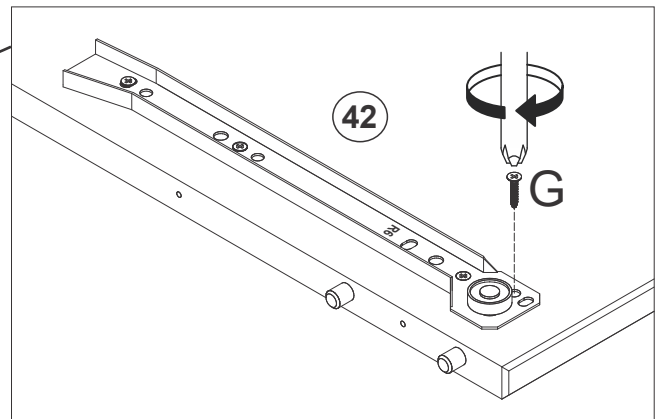
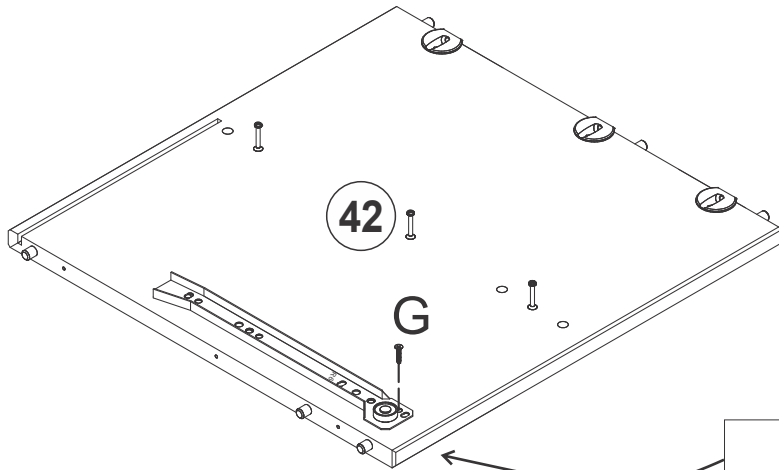
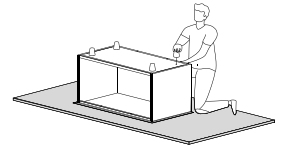

# Step 6

Secure Top panel (45) to Right Side Panel (42) inserting Screw (B) into Plastic fixing device (L) and tighten with a Phillips head screwdriver.

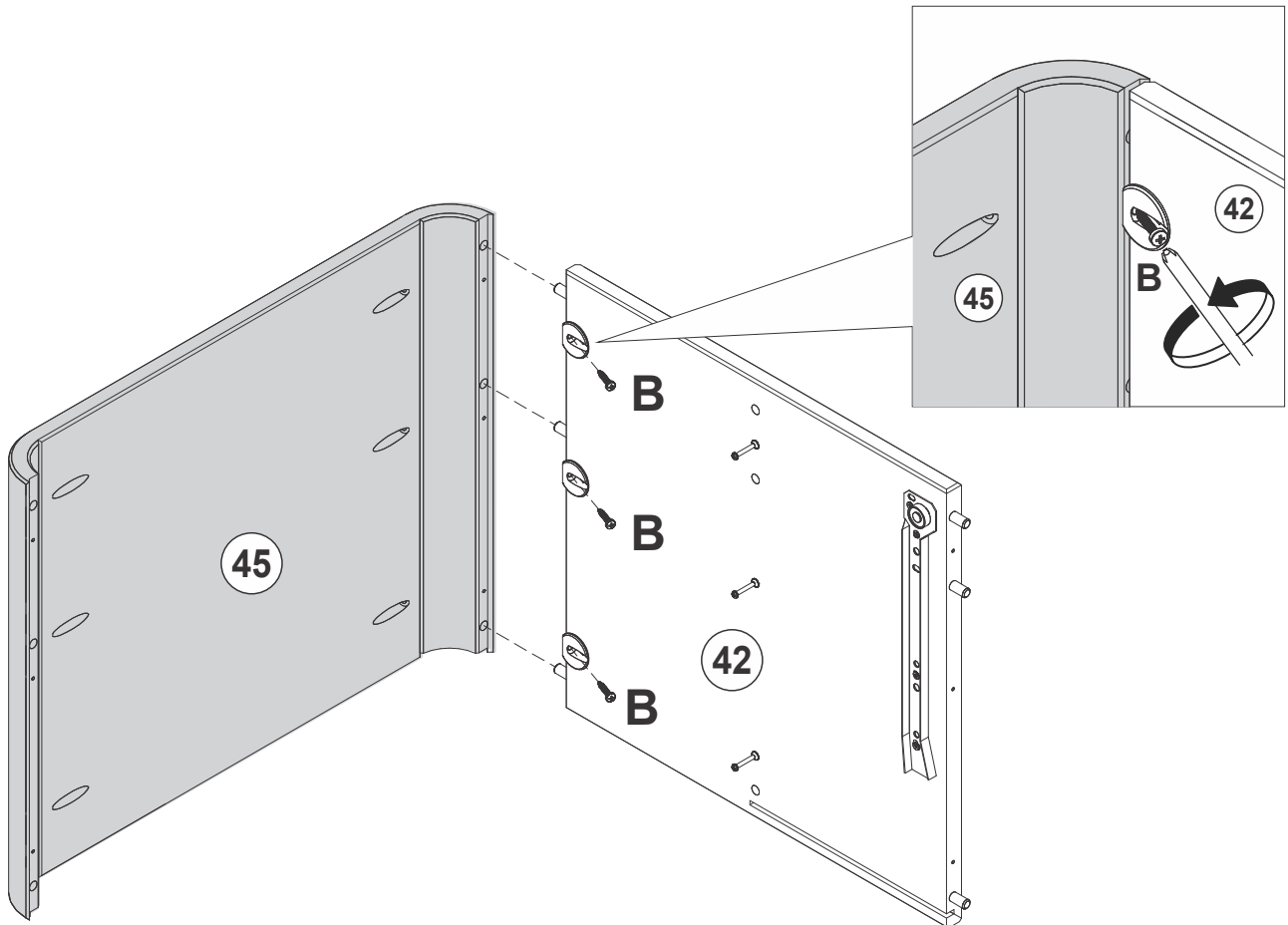
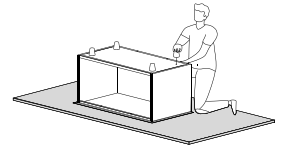

STEP READY

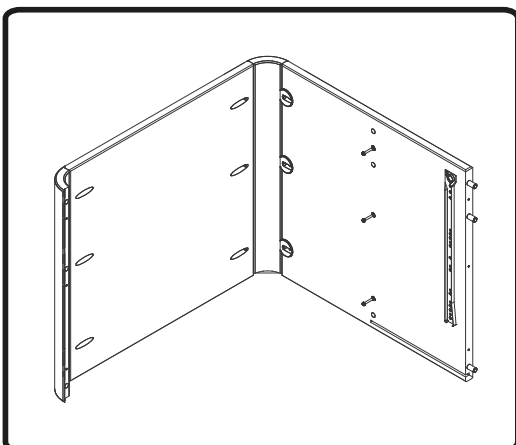

# Step 7

Secure Shelf (25) to Right Side Panel (42) insert Cam locks (E) into the Shelf (25) and tighten with a Phillips head screwdriver.

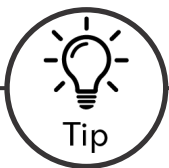
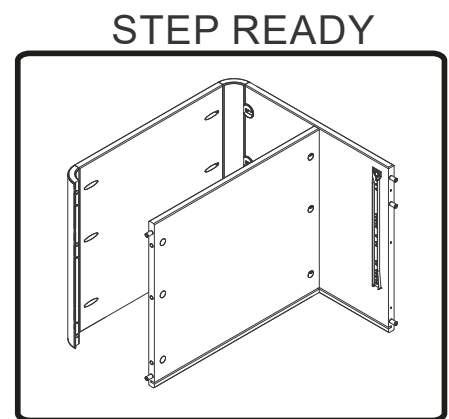
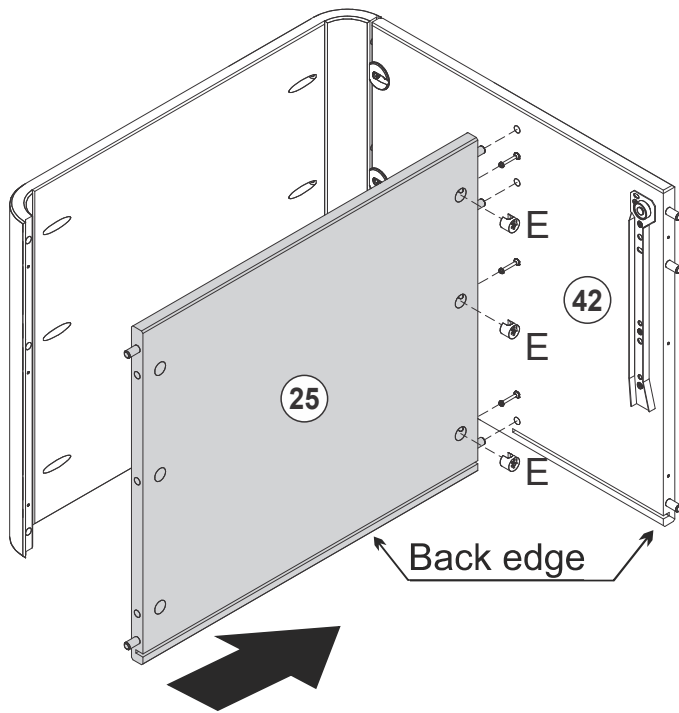
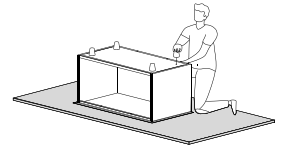

Tip

## Cam Locks

Cam Locks help securely join two pieces together.

Follow these easy steps.

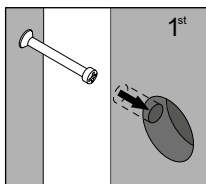

1: Insert Cam Bolt into bolt holes on the flat side. Don't over tighten!

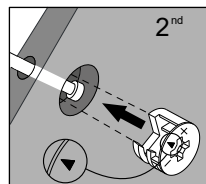

2: Assemble both parts together. The cam bolts goes in the drilled holes that have a circular hole on the side, you should be able to see the cam bolt through it. After fitting parts together insert the cam lock on the side holes.

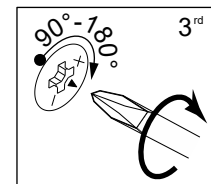

3: On the back of the Cam Lock will be a 'C' shape. Insert the Cam Lock so the opening of the 'C' fits over the Cam Bolt. Tighten with the screwdriver.

# Step 8

Secure Left Side Panel (43) to the Top Panel (45) using wooden dowels. Also fit the Cam bolts (I) into Shelf (25) fixate using Cam locks (E) and a Phillips head screwdriver.

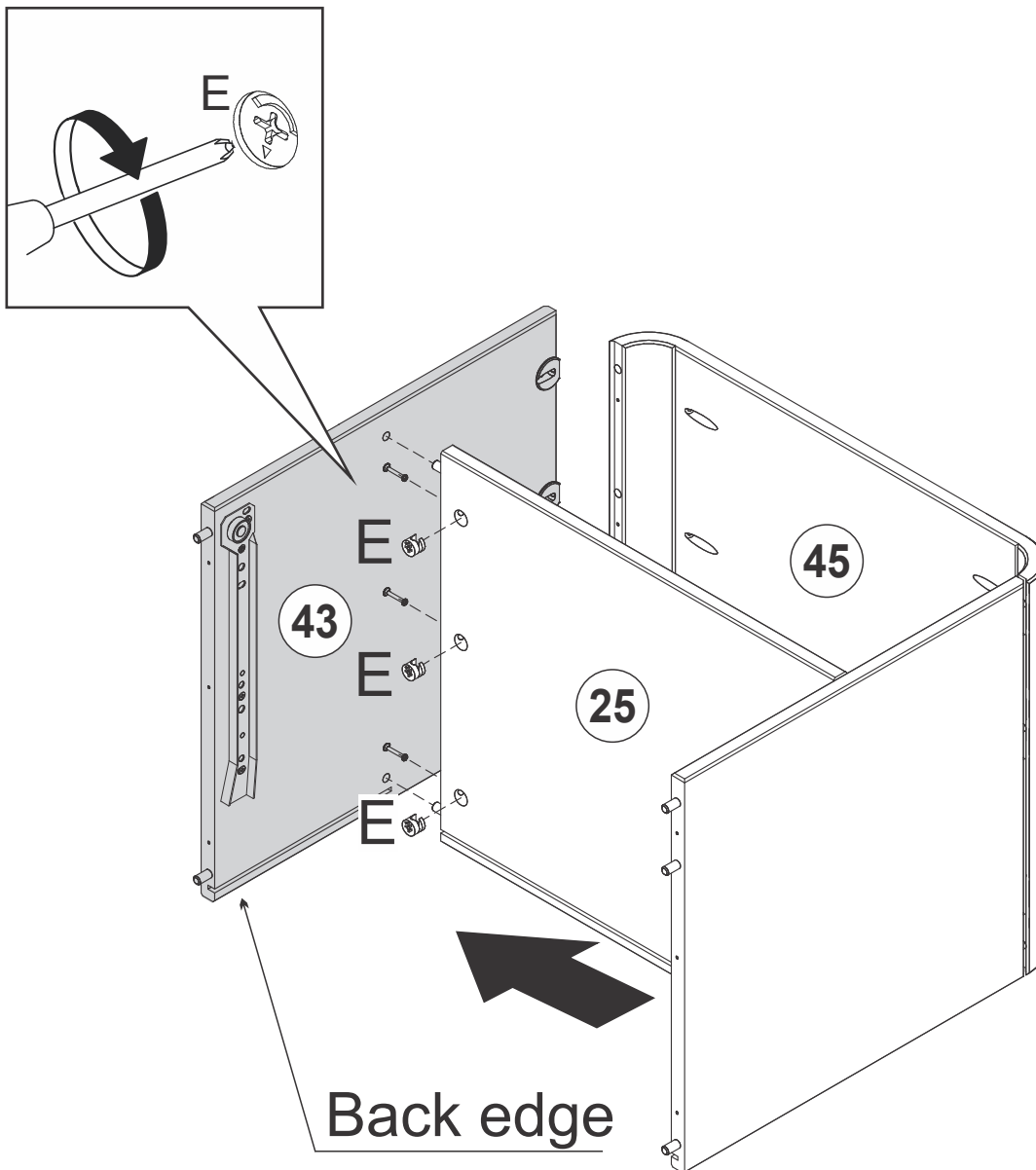
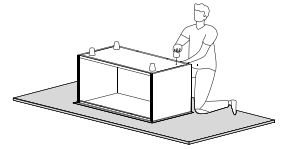



# Step 9

Secure Left Side Panel (43) to Top Panel (45). Insert Screw (B) into Plastic fixing device (L) and tighten with a Phillips head screwdriver.

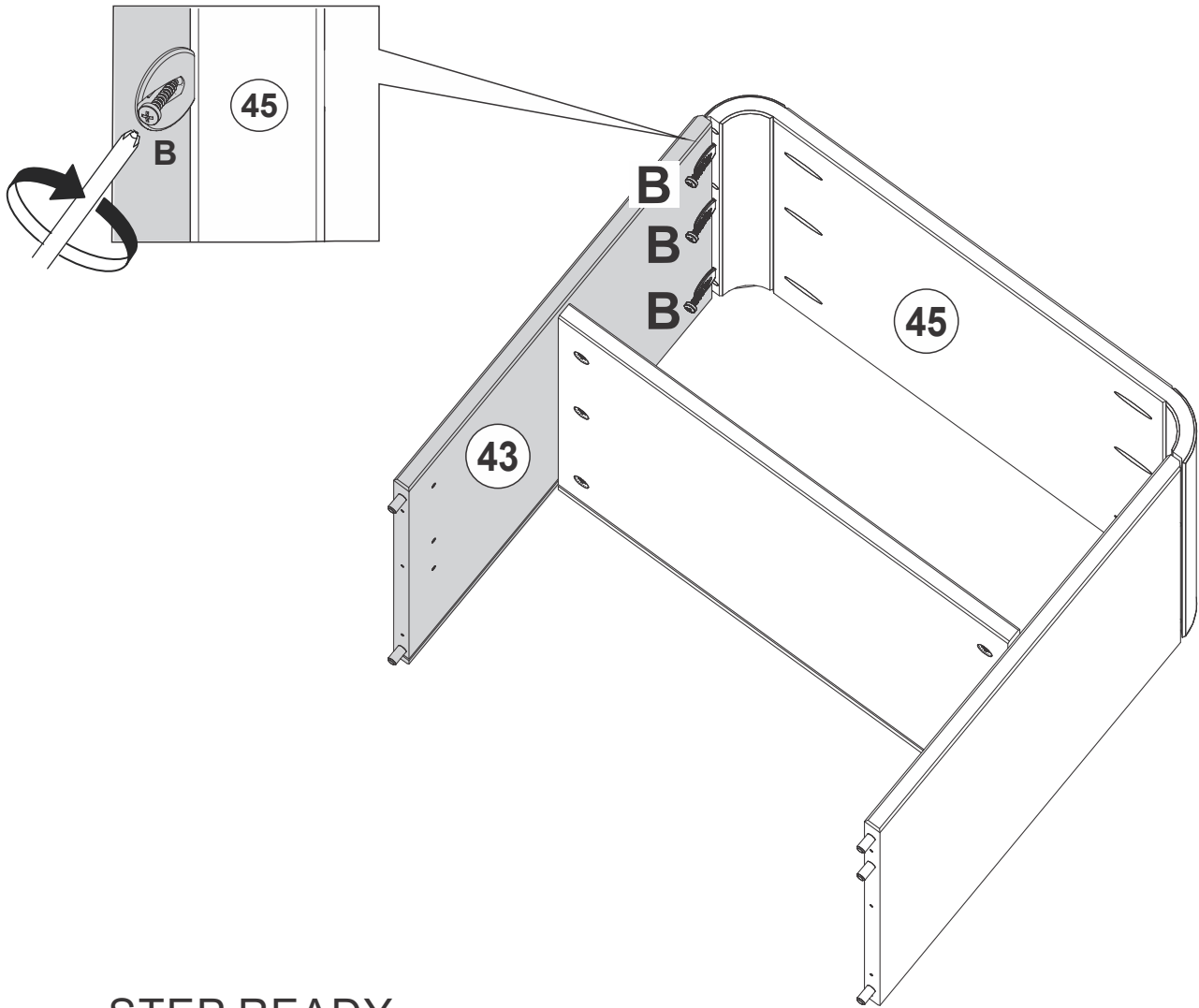
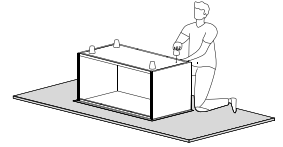

STEP READY

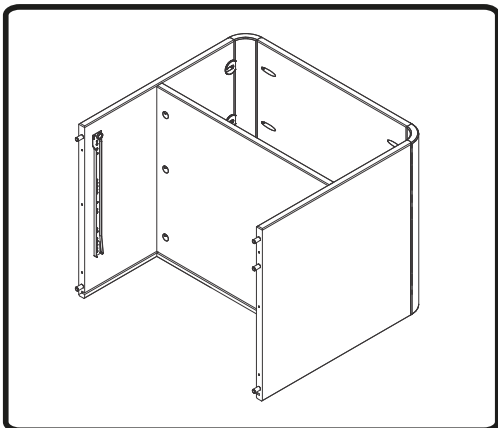

# Step 10

Slide Back Panel (07) on the grooves on Right Side Panel (42) and Left Side Panel (43).

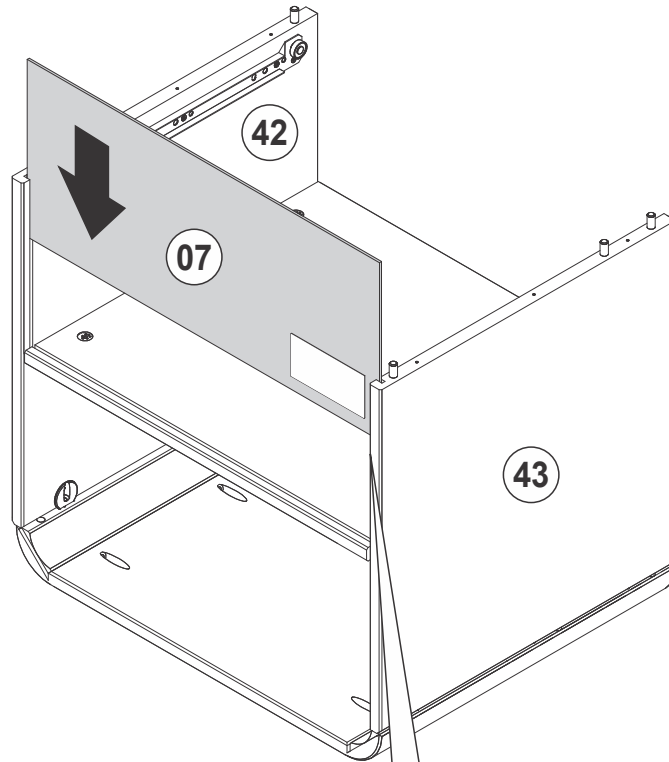
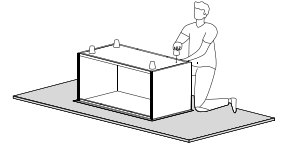

Name and address of the supplier and date of production.

**STEP READY**

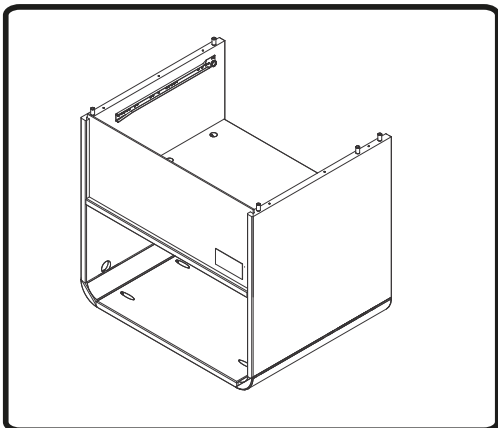

# Step 11

Assemble the Feet (26) to Bottom panel (24) using Bolt (H) and Hex key (K).

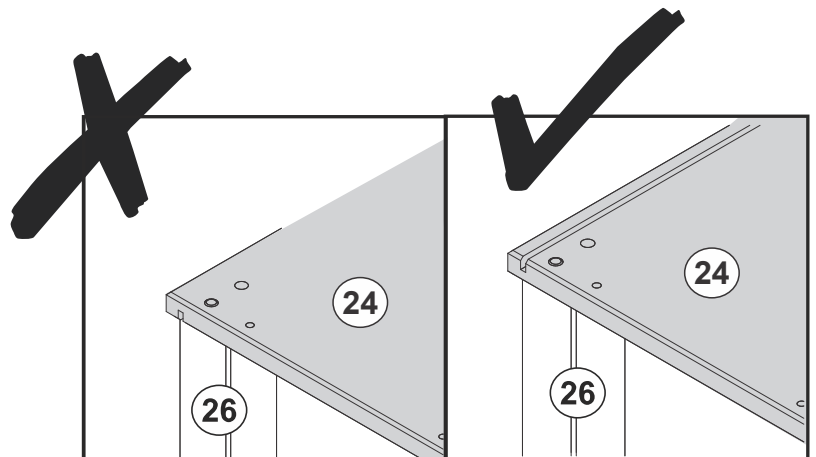
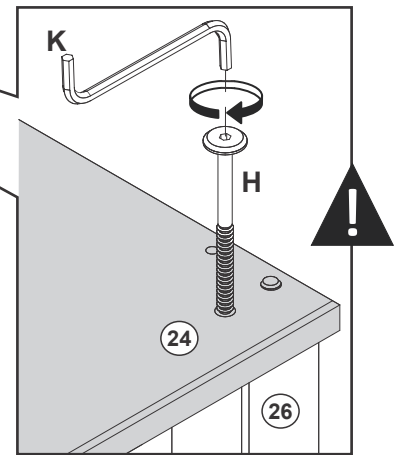
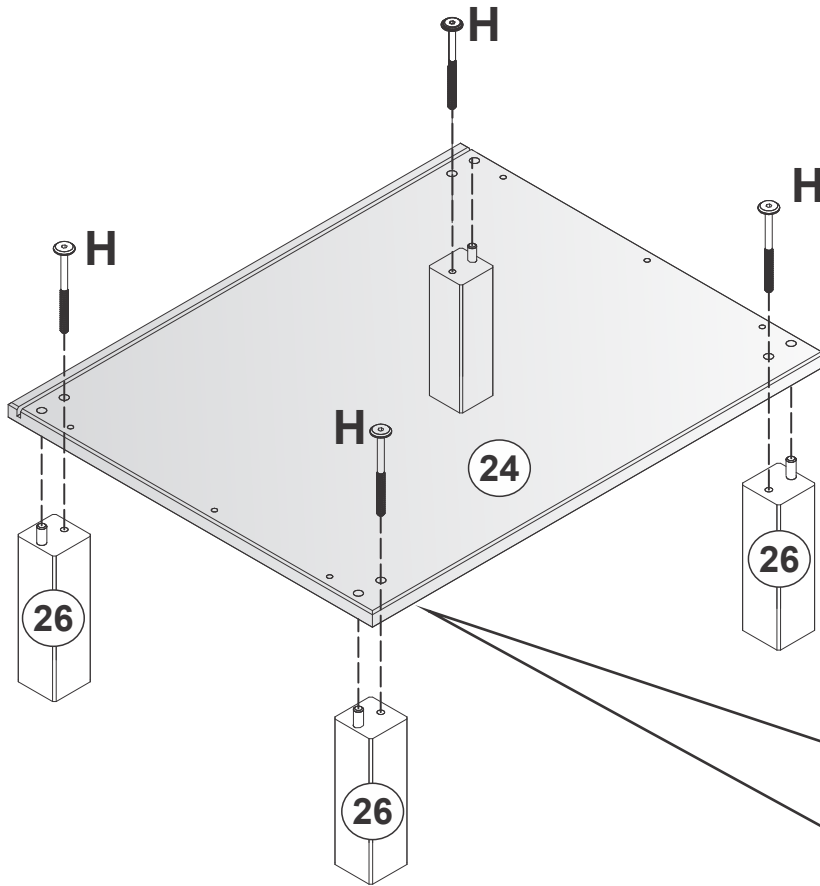
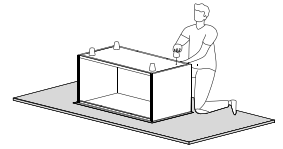

# Step 12

Secure Bottom Panel (24) to Right Side Panel (42) and Left Side Panel (43) with Screw (D) and a Phillips head screwdriver.

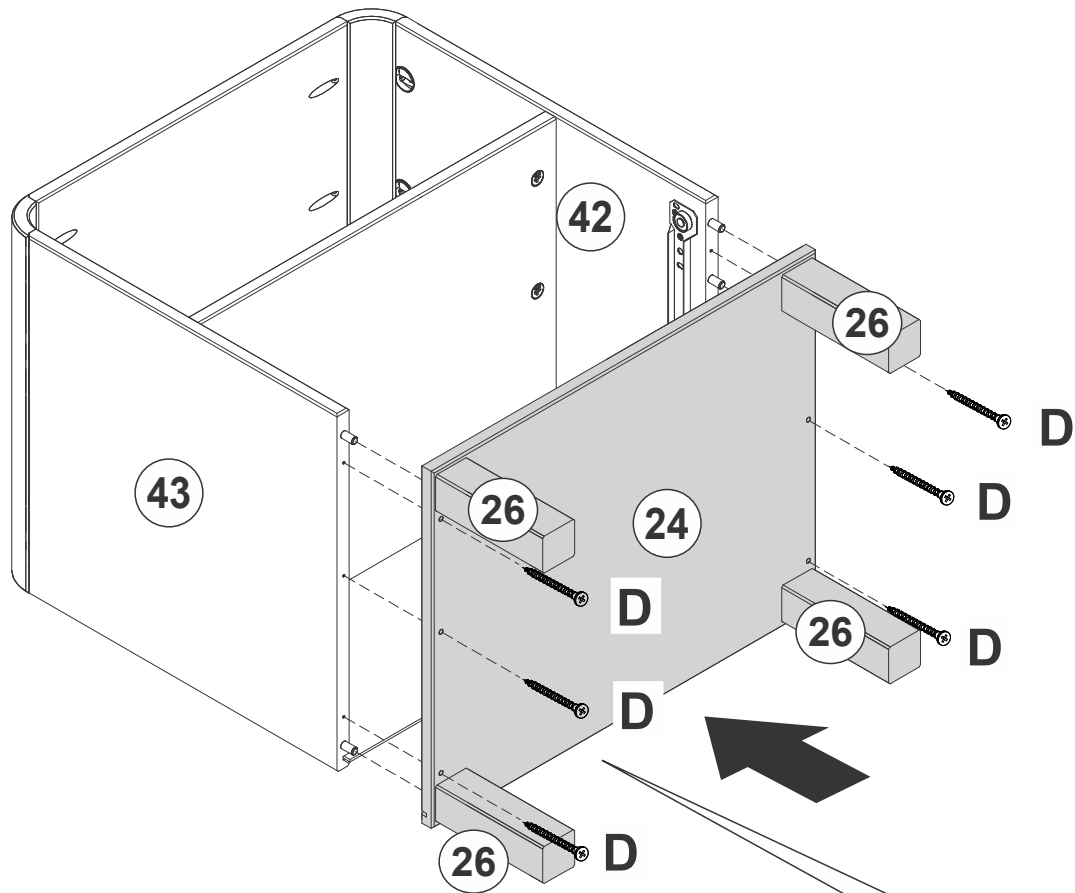
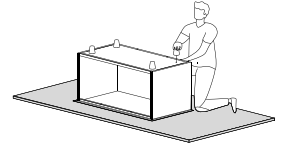

STEP READY

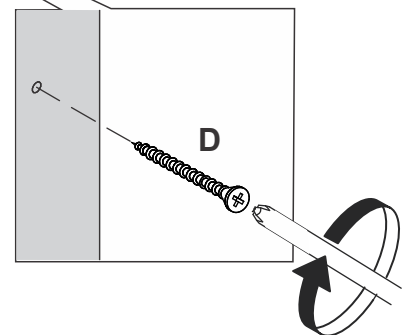
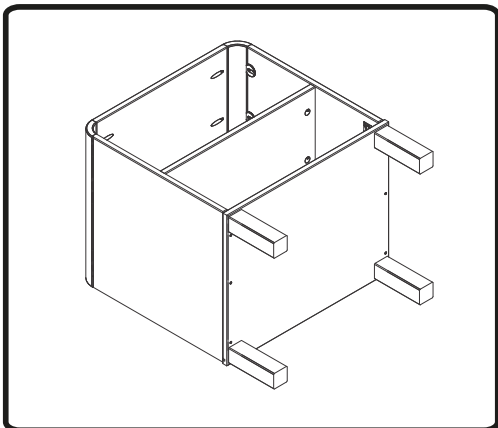

# Step 13

Remove the felt sticker from the paper.  
Glue the felt to the bottom of the feet.

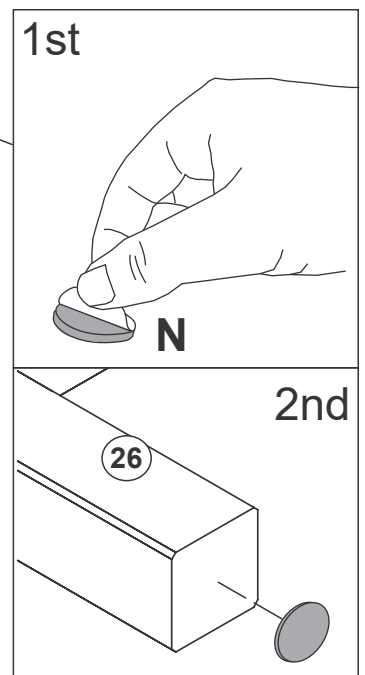
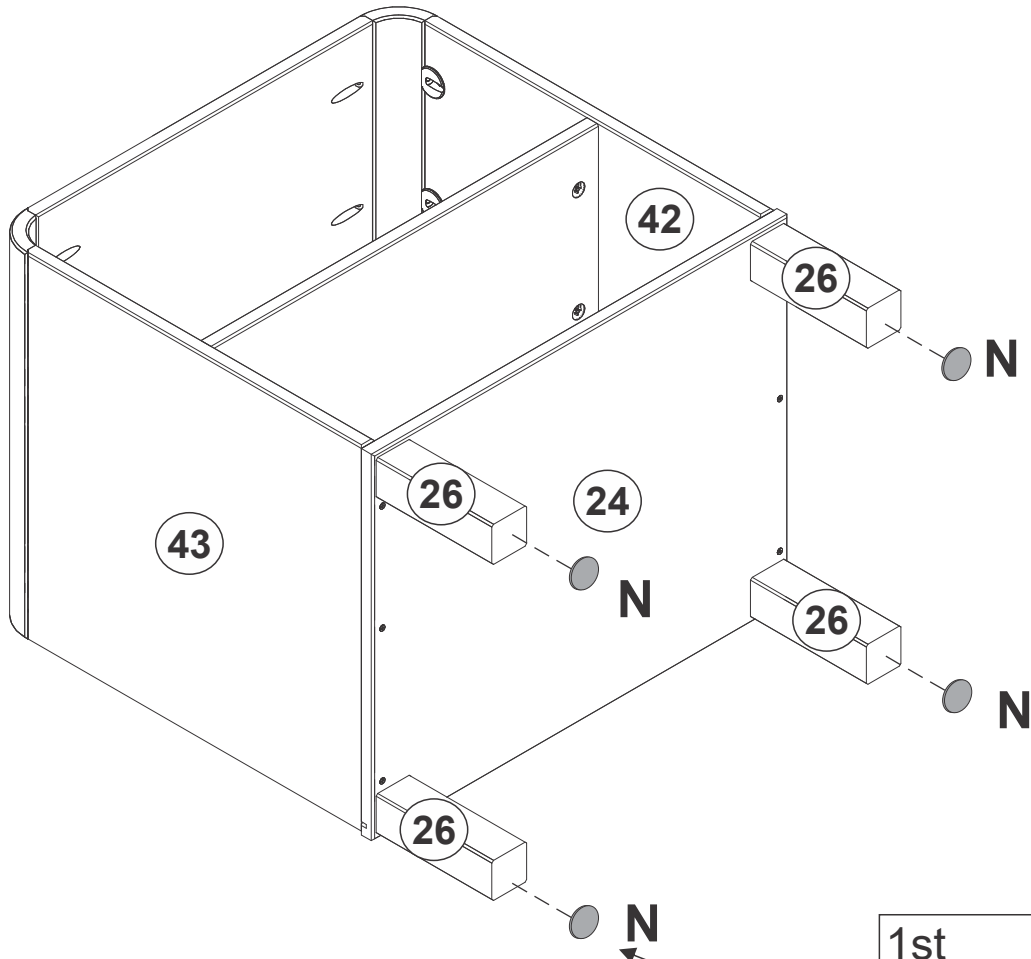
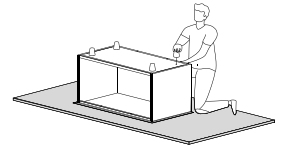

# Step 14

Secure the Left Drawer Side (29) and Right Drawer Side (30) to Drawer Front (44) using Cam Lock (E) and a Phillips head screwdriver.

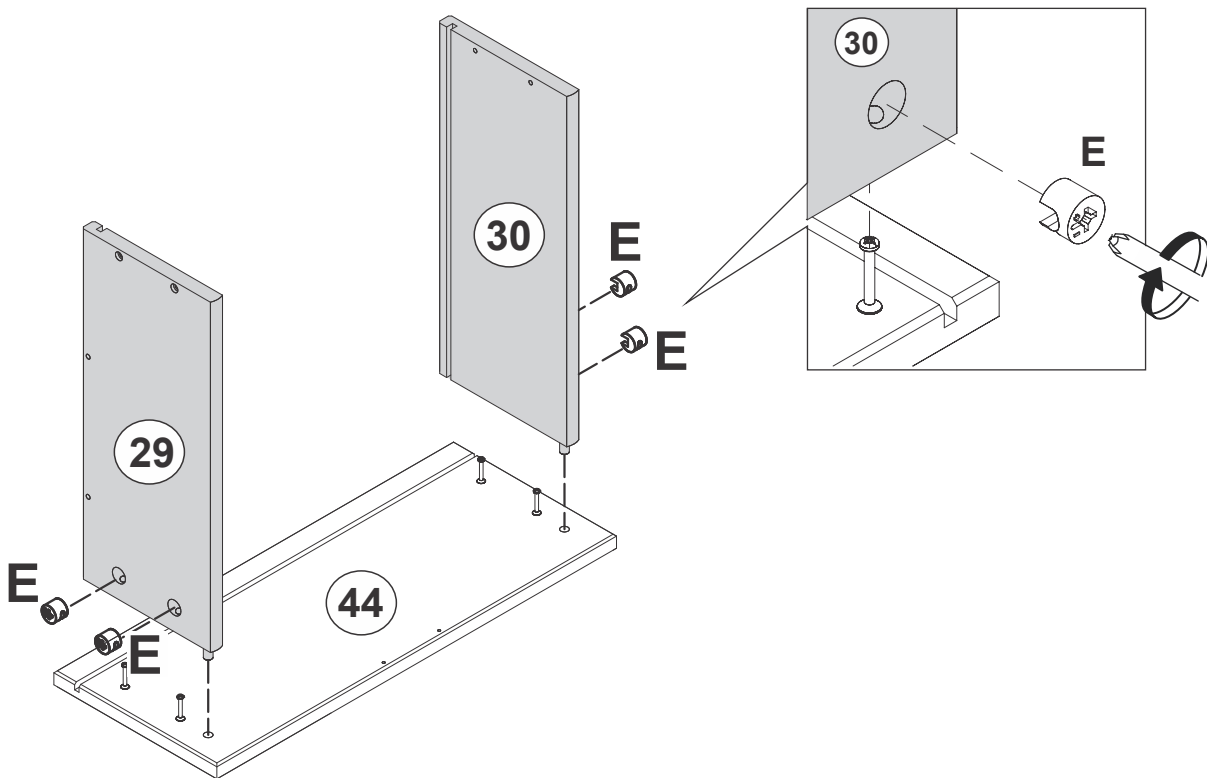
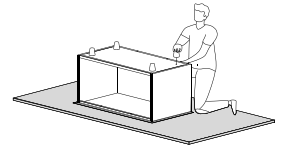

STEP READY

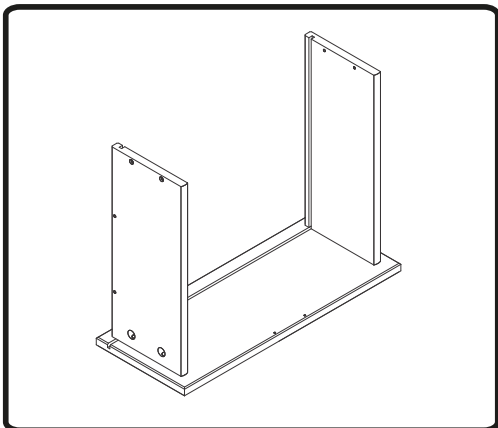

# Step 15

Slide Drawer Bottom (27) on the grooves on Left Drawer Side (29) and Right Drawer Side (30) fitting in Drawer front (44).

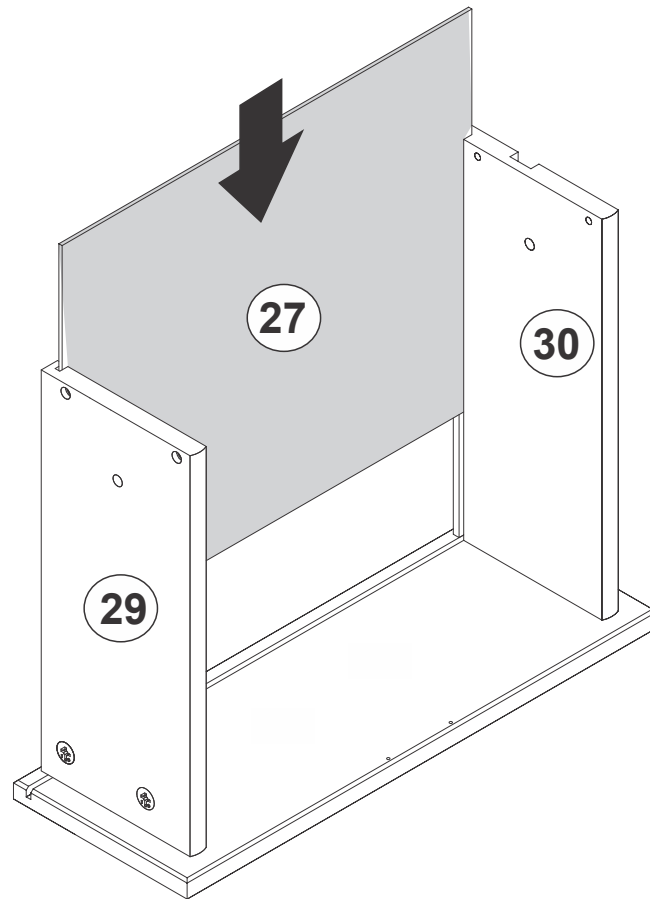
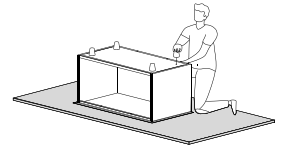

# Step 16

Join Drawer Back (46) to Left Drawer Side (29) and Right Drawer Side (30) using Screw (C) and a Phillips head screwdriver.

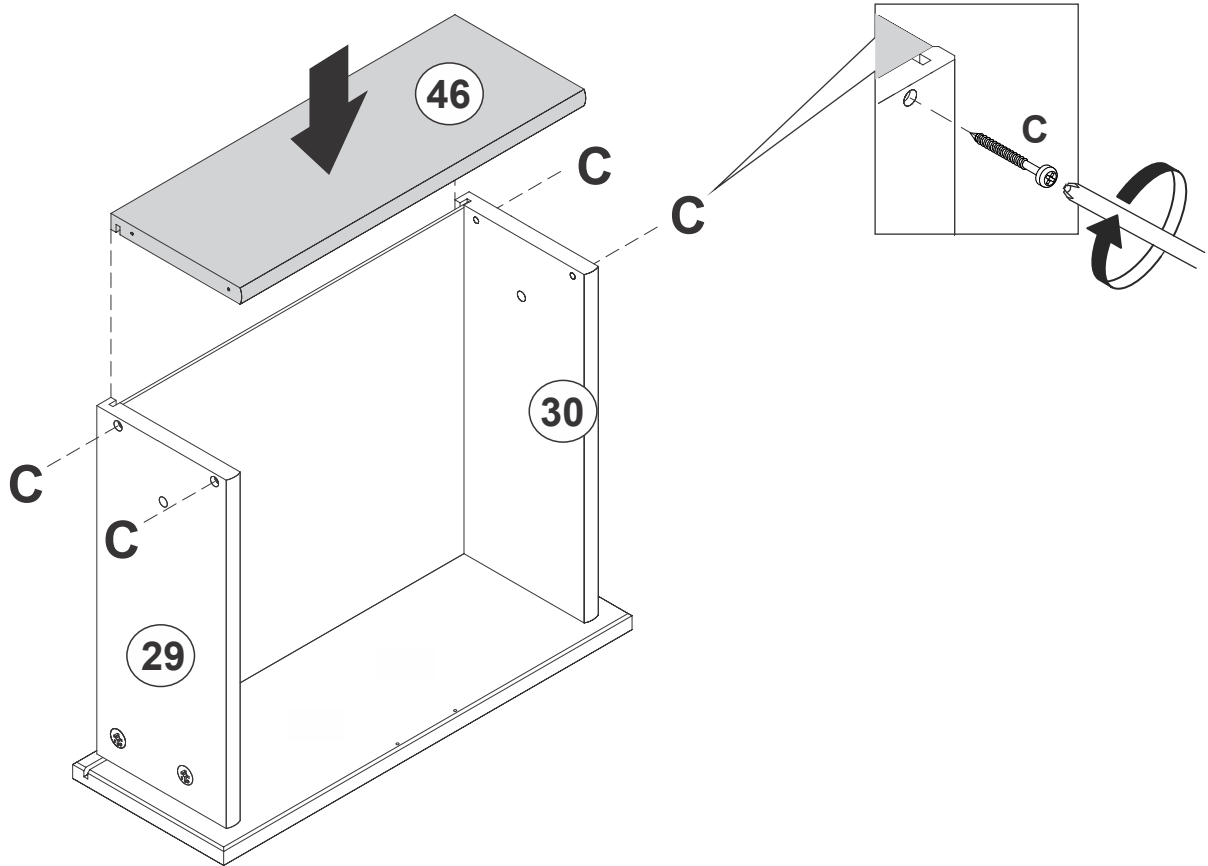
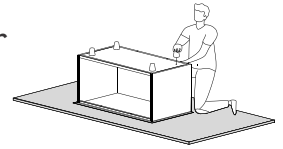

STEP READY

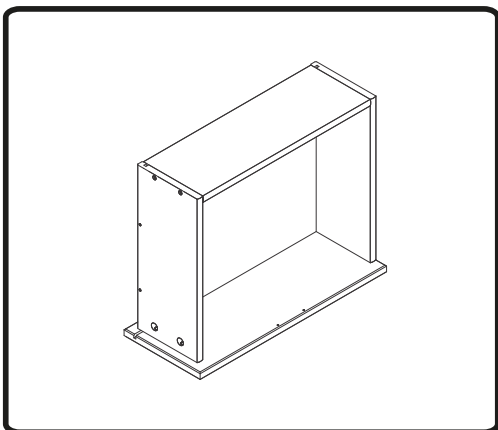



# Step 17

Attach Handle (J) using Screw (G) and a Phillips head screwdriver.

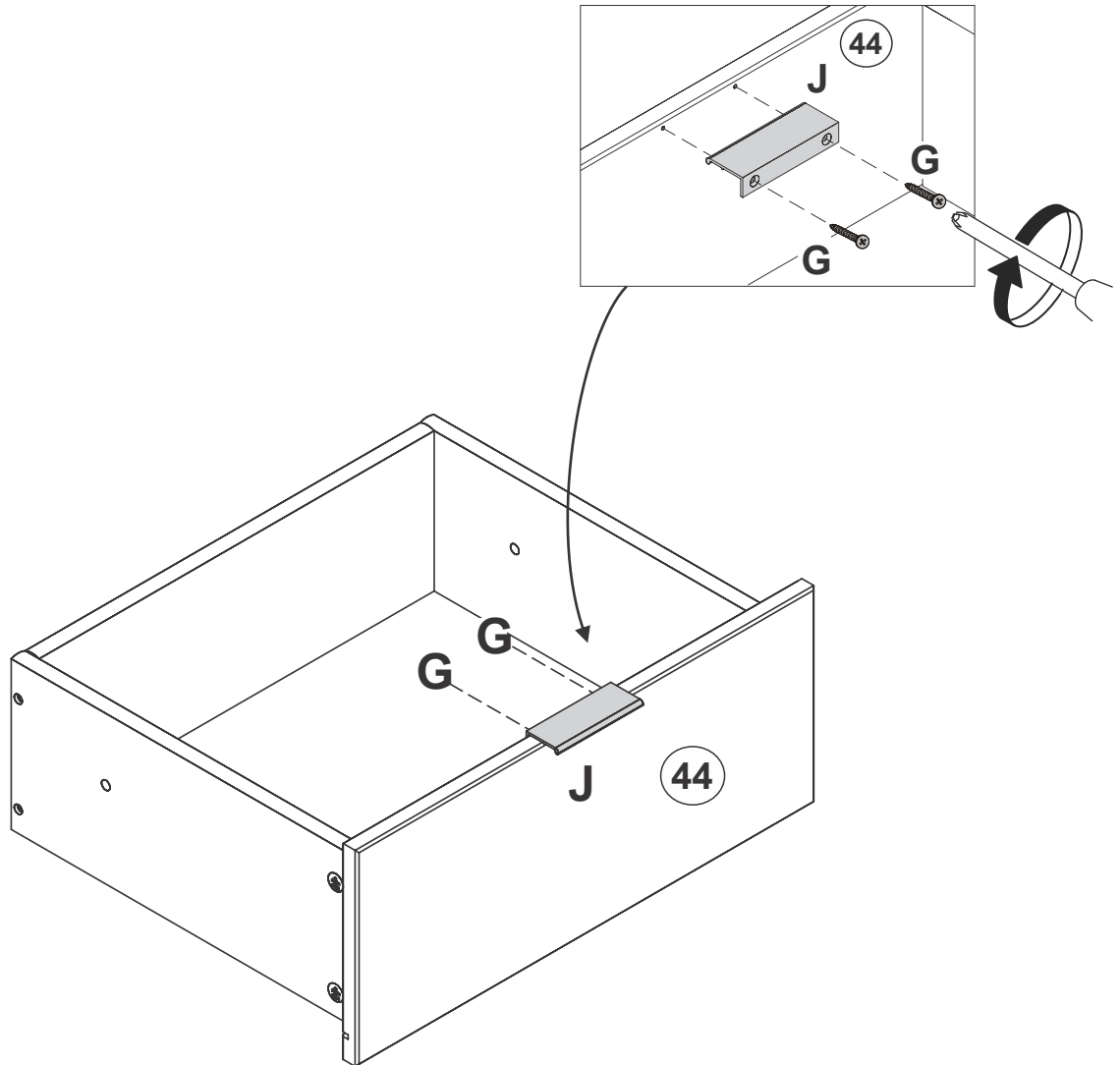
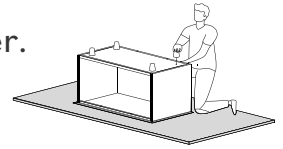

# Step 18

Secure Right Drawer Slide (Q) to Right Drawer Side (30) with Screw (F), and a Phillips head screwdriver. Also secure Left Drawer Slide (R) to Left Drawer Side (29) using Screw (F), tighten with a Phillips head screwdriver. Pay attention to the details in the images below.

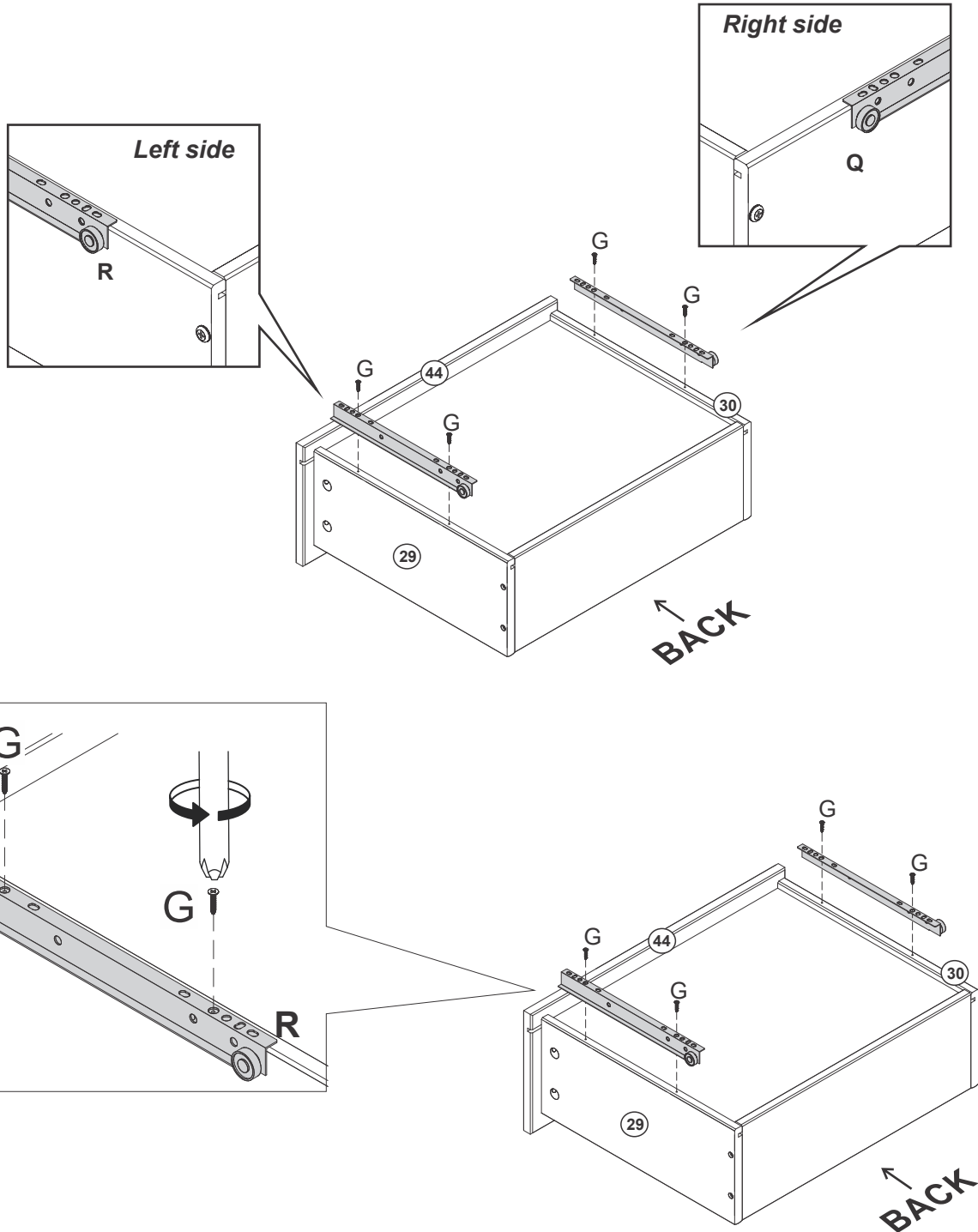
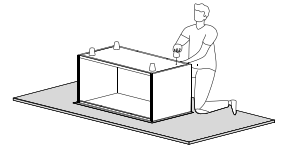

# Step 19

Insert Cover (M) into Plastic fixing device (L) in Right Side Panel (42) and Left Side Panel (43).

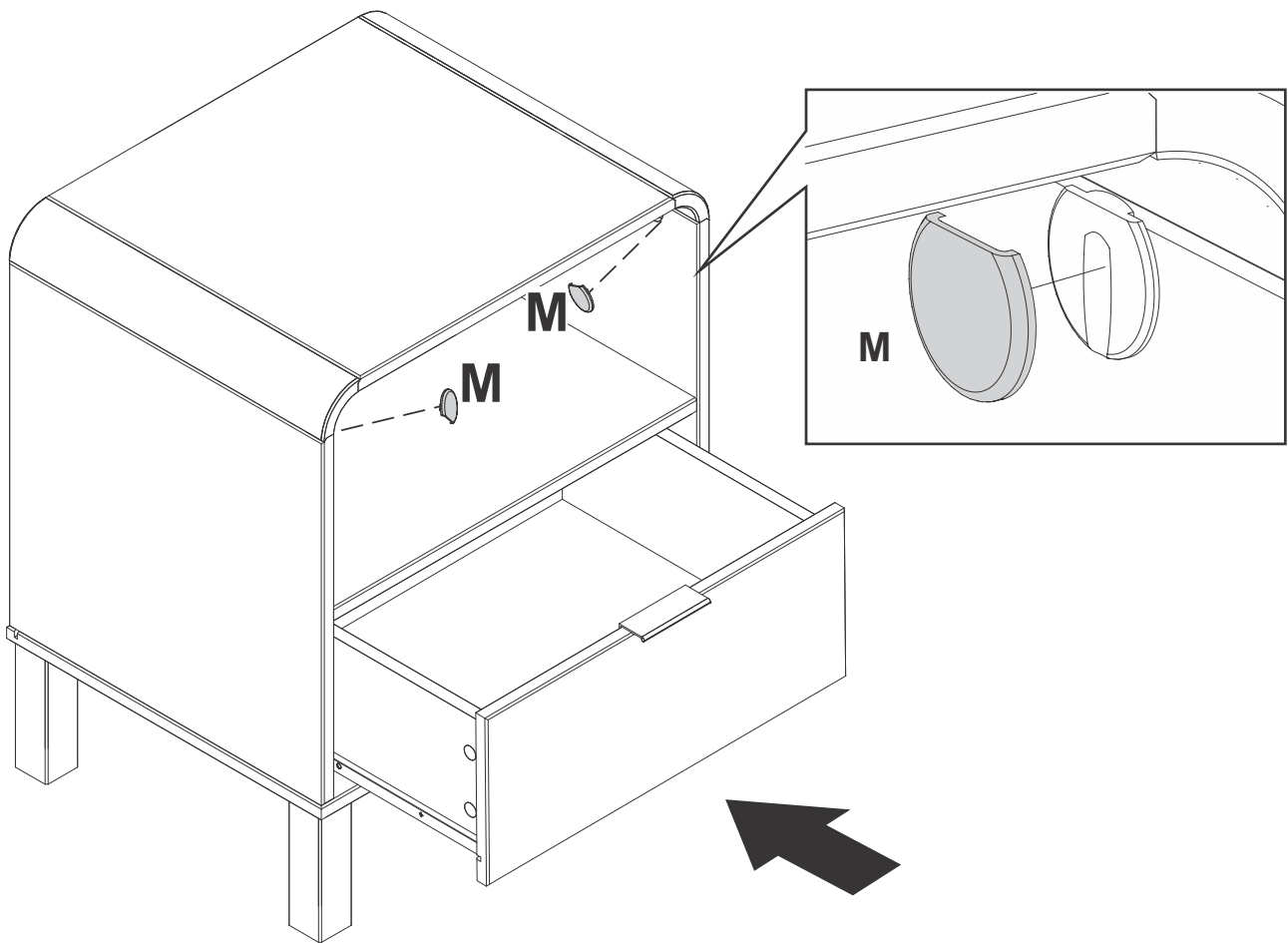
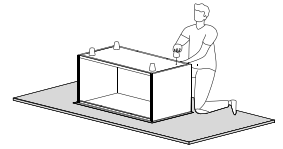

1 - Fit the Right drawer slide (Q) into the Right side slide support (O).

2 - Fit the Left drawer slide (R) into the Left side slide support (P).

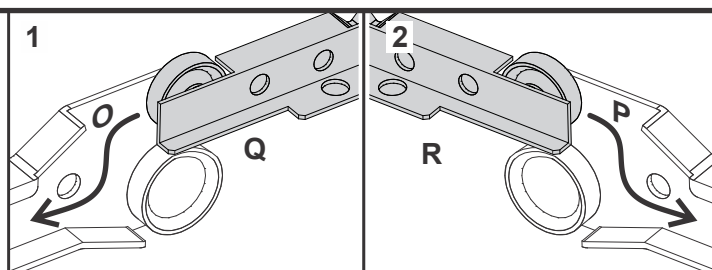

You did it! Enjoy your new nightstand!

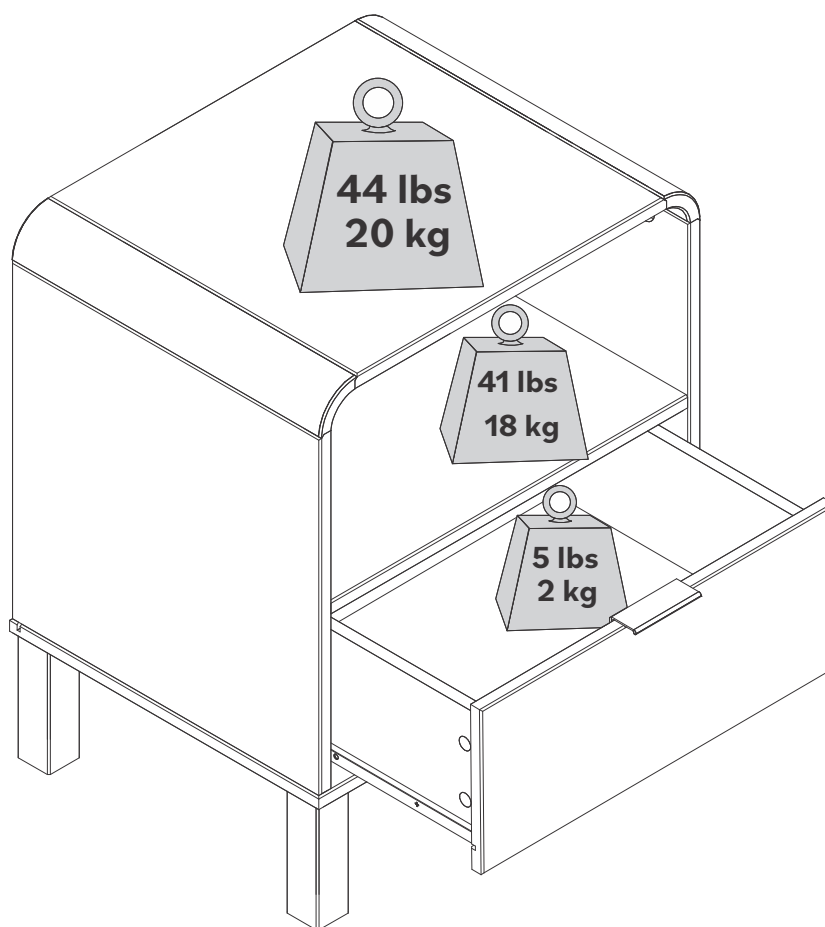

Congratulations on you new piece of furniture!  
We would love to hear about it and see it.  
Please leave us a review or post a picture with  
[#mywalkerredisonhome](#)

# Assembling furniture can be tricky sometimes.

Our customer service team, located in Utah, is here for product information, help assembling a product, or for any other customer support issue

Call us at **801-433-3008**

Email us at **[service@walkeredison.com](mailto:service@walkeredison.com)**

Visit our Customer Service website at **[walkeredison.com/pages/customer-service](http://walkeredison.com/pages/customer-service)**

We are available to help Monday-Thursday 8am-5pm, Friday 8am-3pm MST

For details on Assembly Videos, Assembly Instructions, Replacement Parts, and Customer service,

**SCAN HERE**

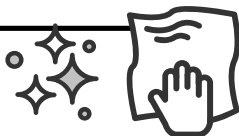

For cleaning, never use abrasives, use a soft cloth and water with neutral soap to clean the furniture.

# WALKER EDISON™

Elias Table de chevet Moderne à Cadre Incurvé en Bois Massif

Elias Mesita de Noche Moderna de Madera Maciza con Estructura Curvada

SKU: ELIB4C  
LOT: **AAYYWW-XXX**

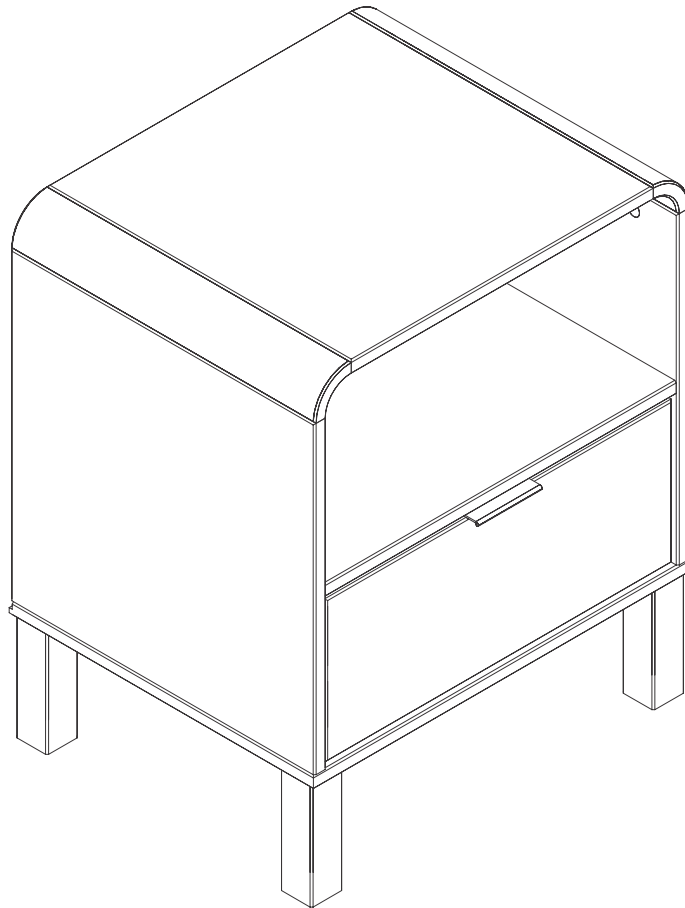

## *Pour usage résidentiel seulement*

Visite notre site Web pour obtenir les instructions les plus récentes, des conseils d'assemblage, signaler des dommages ou commander des pièces. [www.walkerredison.com](http://www.walkerredison.com)

## *Sólo para uso residencial*

Visite nuestro sitio web para consultar las últimas instrucciones, consejos de montaje, notificar daños o solicitar piezas. [www.walkerredison.com](http://www.walkerredison.com)

# WE Il est temps de commencer / Hora de empezar

Prépare un lieu de travail propre et souple pour éviter tout dommage lors de l'assemblage. Tu peux utiliser la boîte et les protections internes comme base. Vérifie également que tu disposes de toutes les pièces et parties avant de te lancer dans l'assemblage.

Prepare un lugar de trabajo limpio y blando para evitar daños durante el montaje. Puede utilizar la caja y las protecciones internas como base. Comprueba también que tiene todas las piezas y partes antes de sumergirse en el montaje.

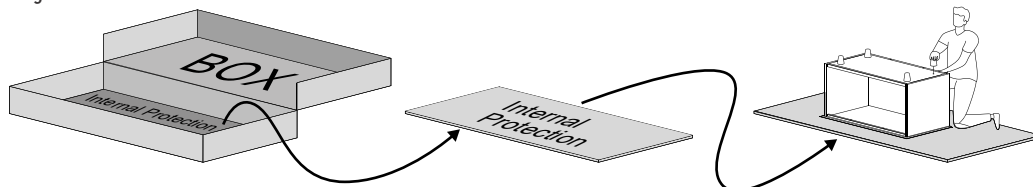

**Temps de montage  
estimé**  
**Tiempo estimado  
de montaje**

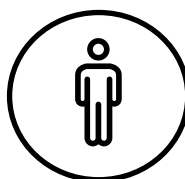

1 Person Build

## **Vous pouvez le faire seul.**

Mais vous pouvez en faire un travail d'équipe !  
Demandez à un ami de vous aider à l'assembler  
plus rapidement et plus facilement.

## **Puedes hacerlo solo**

Pero también puedes hacerlo en equipo.  
Llévate a un amigo para que el montaje  
sea más rápido y sencillo.

## **Outils nécessaires**

Munis-toi d'un tournevis cruciforme pour réaliser cet assemblage

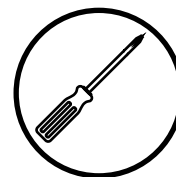

## **Herramientas requeridas**

Tome un destornillador Phillips para conquistar este conjunto.

## **Utilise les outils électriques avec précaution**

Ce meuble est réalisé en Bois Massif et Bois Composite, des matériaux souples. Si tu choisis d'utiliser des outils électriques, règle-les sur le mode le plus lent. Fais attention à toi ! Les outils électriques peuvent provoquer des fissures ou endommager les meubles, mais aussi les autres composants s'ils sont mal utilisés. Les dommages causés par un outil électrique ne sont pas couverts par la garantie Walker Edison.

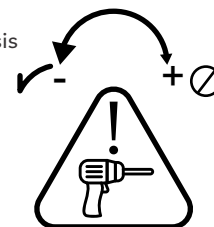

## **Utilice las herramientas eléctricas con cuidado**

Este mueble está fabricado con madera maciza y madera compuesta, materiales blandos. Si decide utilizar herramientas eléctricas, ajústelas al ajuste más lento. Tenga cuidado. Las herramientas eléctricas pueden causar grietas o daños en el mueble, pero también en los herrajes si se utilizan mal. Los daños causados por una herramienta eléctrica no están cubiertos por la garantía de Walker Edison.



**Scannez pour obtenir des conseils d'assemblage et de l'aide !**  
**Escanee para obtener consejos de montaje y ayuda!**

# WE Liste de pièces / Lista de piezas

Nombre de pièces Número de pieza	Description Descripción	Quantité Cantidad
07	Panneau Arrière Panel Trasero	01
24	Panneau Inférieur Panel Inferior	01
25	Étagère Estante	01
26	Pieds Pies	04
27	Fond du Tiroir Inferior del Cajón	01
29	Côté Gauche du Tiroir Lado Izquierdo del Cajón	01
30	Côté Droit du Tiroir Lado Derecho del Cajón	01
42	Panneau Droit Panel Derecho	01
43	Panneau Gauche Panel Izquierdo	01
44	Façade du Tiroir Frènte del Cajón	01
45	Panneau Supérieur Panel Superior	01
46	Arrière du Tiroir Trasero del Cajón	01

**WALKER EDISON**  
 Distribution By:  
 Walker Edison Furniture Company  
 1553 W 9000 S, West Jordan,  
 UT 84088 United States

**ELIAS**  

Model: XXXXXXXXFF  
 LOT: AAYYWW-XXX  
 Date: MM/20YY  
 Rev. MM/20YY-VX





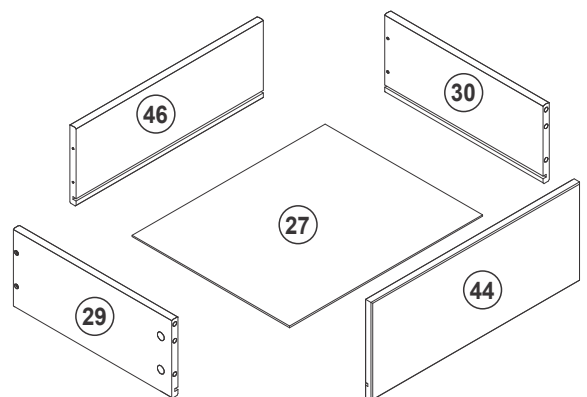
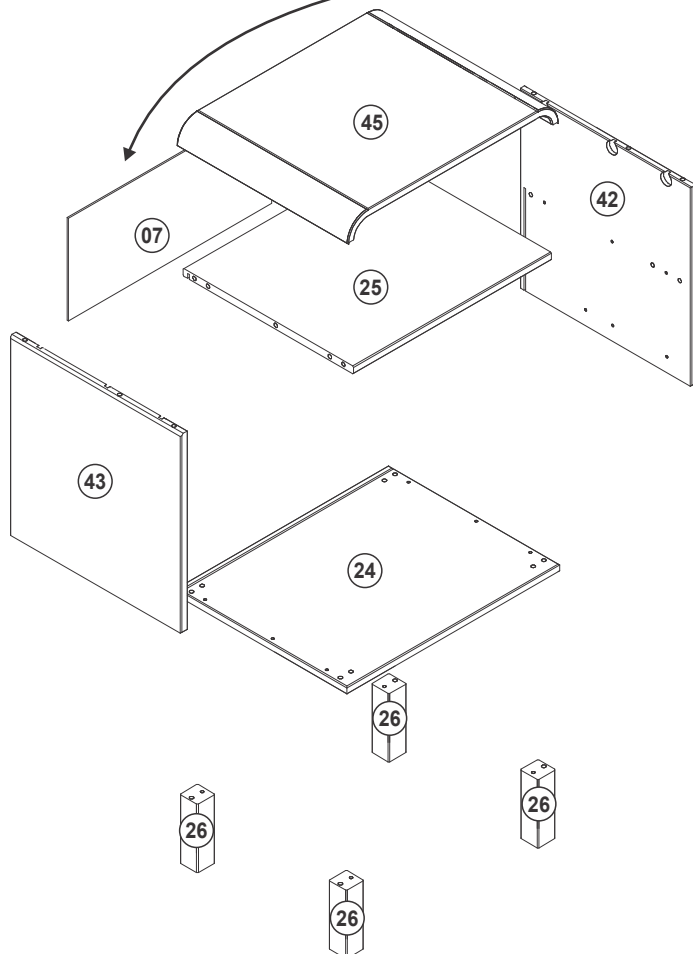



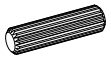
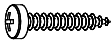
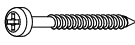

CANFER compliant / conforme au CANFER  
 TSCA Title VI compliant / conforme au titre VI de la TSCA  
 TSCA Title VI certified / certificado conforme al título VI de la TSCA  
 California 81/2012 Compliant for Formaldehyde /  
 Conforme à la norme California 81/2012 pour le formaldéhyde.

For details on Assembly Videos, Assembly Instructions,  
 Replacement Parts and Customer Service, SCAN HERE



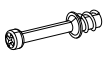
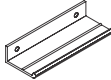
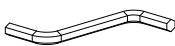

## WE Liste de composants / Lista de hardware

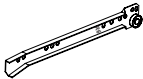
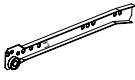
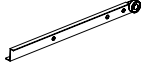
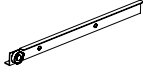
Partie Parte	Taille Tamaño	Nom Nombre	Quantité Cantidad
A 	8x30mm	Cheville Espiga	22
B 	3,5x20mm	Vis Tornillo	06
C 	3,5x30mm	Vis Tornillo	04
D 	4x40mm	Vis Tornillo	06
E 	15x12mm	Boitier de Assemblage Traba del Conector	10
F 	6x8mm	Vis Tornillo	06
G 	3,5x14mm	Vis Tornillo	08
H 	7x80mm	Boulon Perno	04
I 	5x24mm	Goujon de Assemblage Conector	10
J 		Poignée Manija	01
K 		Clé Allen Llave Allen	01
L 	26mm	Dispositif de fixation en plastique Dispositivo de fijación de plástico	06
M 	33mm	Cache Tapa	06
N 	30mm	Feutre Fieltro	04
O 	250mm	Support Glissière Métallique (R6) Soporte Corredera Metálica (R6)	01
P 	250mm	Support Glissière Métallique (L6) Support Glissière Métallique (L6)	01
Q 	250mm	Glissière Métallique Corredera Metálica	01
R 	250mm	Glissière Métallique Corredera Metálica	01

Les quantités de composants indiquées ci-dessus sont nécessaires pour un assemblage correct.  
Des pièces supplémentaires peuvent être incluses.

Las cantidades de tornillería indicadas anteriormente son necesarias para un montaje correcto.  
Se pueden incluir piezas de ferretería adicionales.

# Étape / Paso 1

(FR)

Insérez la Cheville (A) dans l'Étagère (25), Pieds (26), Côté Gauche du Tiroir (29), Côté Droit du Tiroir (30), Panneau Droit (42) et le Panneau Gauche. (43).

(ES)

Inserte la Clavija (A) en el Estante (25), Pies (26), Lado Izquierdo del Cajón (29), Lado Derecho del Cajón (30), Panel Derecho (42) y el Panel Izquierdo. (43).

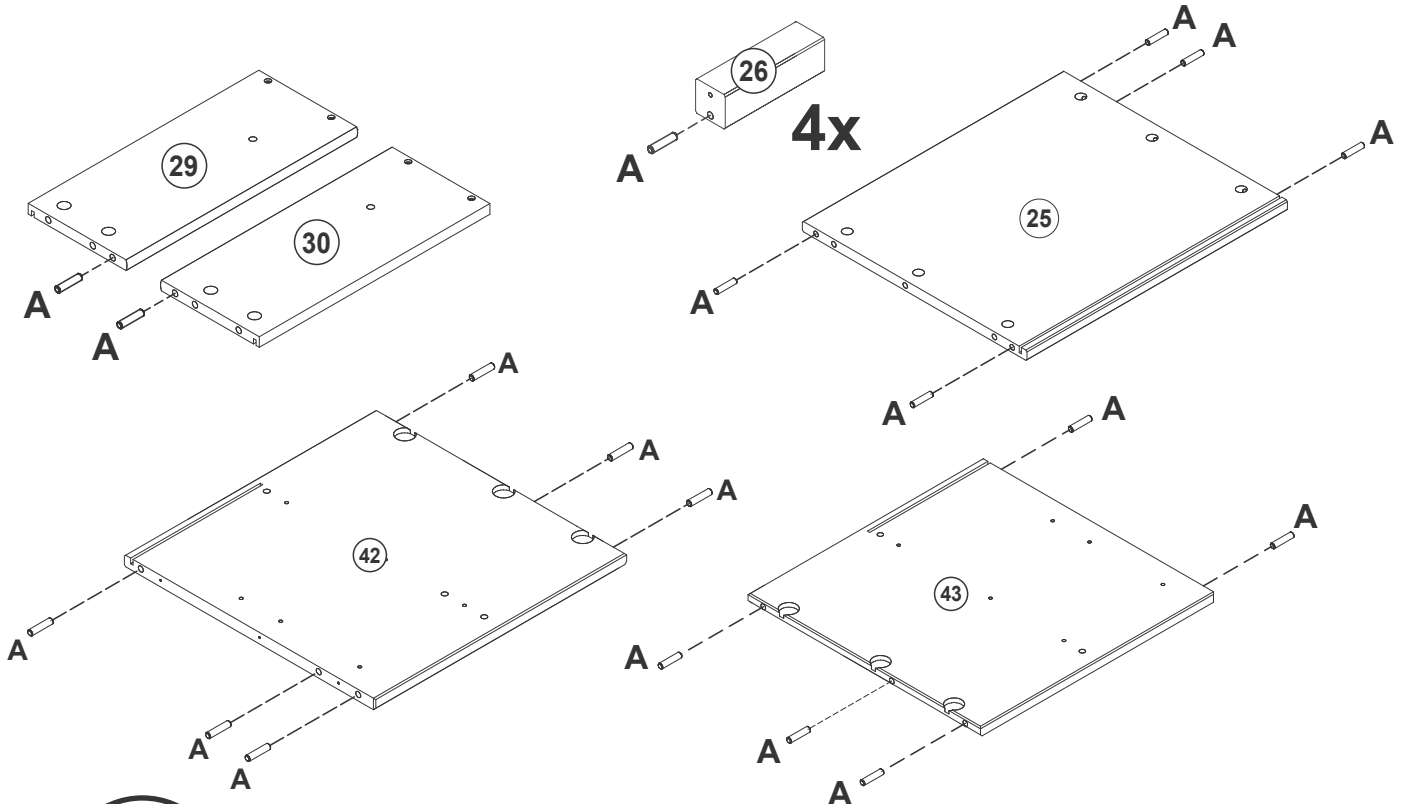
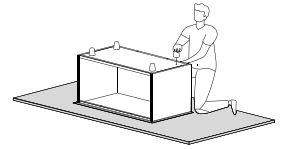

Les chevilles sont essentielles lors de l'assemblage de meubles pour créer des connexions solides et précises. Elles garantissent l'intégrité structurelle, empêchent les déplacements et simplifient l'alignement, ce qui permet d'obtenir des meubles plus résistants et plus durables. Suis ces étapes:

Las espigas son esenciales en el montaje de muebles para crear uniones fuertes y precisas. Garantizan la integridad estructural, evitan el desplazamiento y simplifican la alineación, lo que se traduce en muebles más resistentes y duraderos. Sigue estos pasos:

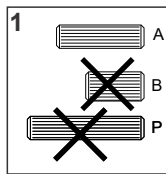

1: Sélectionne la taille de cheville appropriée en fonction de l'étape.  
1: Seleccione el tamaño de espiga adecuado según el paso.

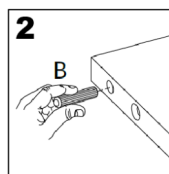

2: Insère dans le trou indiqué et appuie fermement pour assurer un positionnement correct.  
2: Insértela en el orificio indicado y presione firmemente para asegurar su correcta colocación.

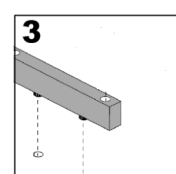
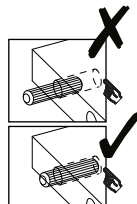

3: Aligne la cheville avec la pièce correspondante et enfonce-la jusqu'à ce qu'elle soit ferme.  
3: Alinee el pasador con la pieza correspondiente y presiónelo hasta que encaje

# Étape / Paso 2

(FR)

Insérez le Goujon de Assemblage (I) avec un tournevis Phillips dans le Panneau Droit (42), Panneau Gauche (43) et la Façade du Tiroir (44).

(ES)

Inserte el Conector (I) con un destornillador Phillips en el Panel Derecho (42), Panel Izquierdo (43) y el Frente del Cajón (44).

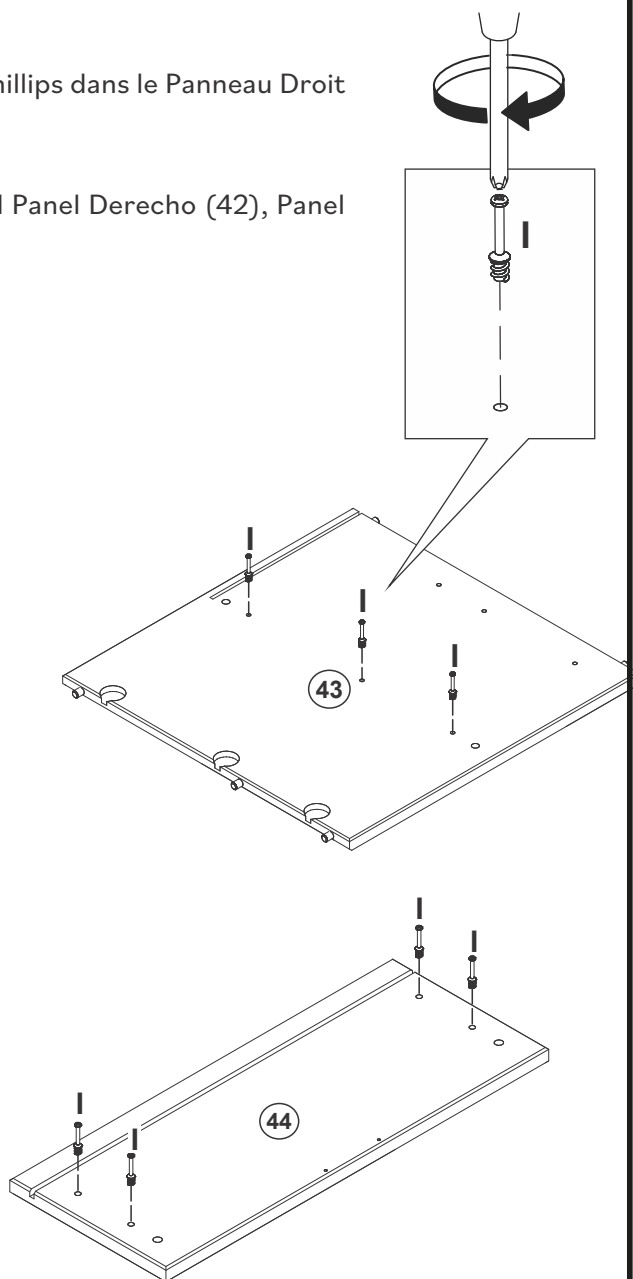
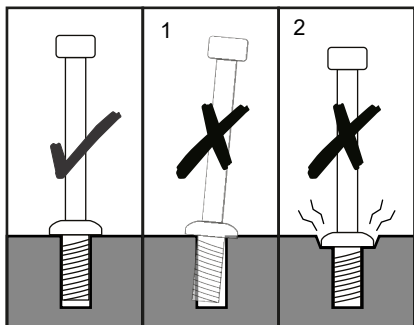

Pour que ton produit conserve son meilleur aspect et sans rayures, essaie de le monter sur une surface souple telle qu'un tapis ou une couverture. Cela permet d'éviter les rayures accidentelles et de garder tes meubles en bon état!

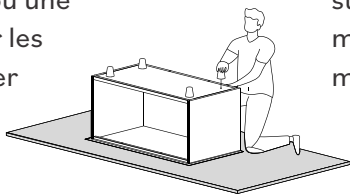

Para mantener su producto con el mejor aspecto y sin arañazos, pruebe a montarlo sobre una superficie blanda, como una alfombra o una manta. Así evitará arañazos accidentales y mantendrá sus muebles en perfecto estado.

# Étape / Paso 3

(FR)

Insérez le Dispositif de Fixation en Plastique (L) dans le Panneau Droit (42) et le Panneau Gauche (43).

(ES)

Inserte el Dispositivo de Fijación de Plástico (L) en el Panel Derecho (42) y en el Panel Izquierdo (43).

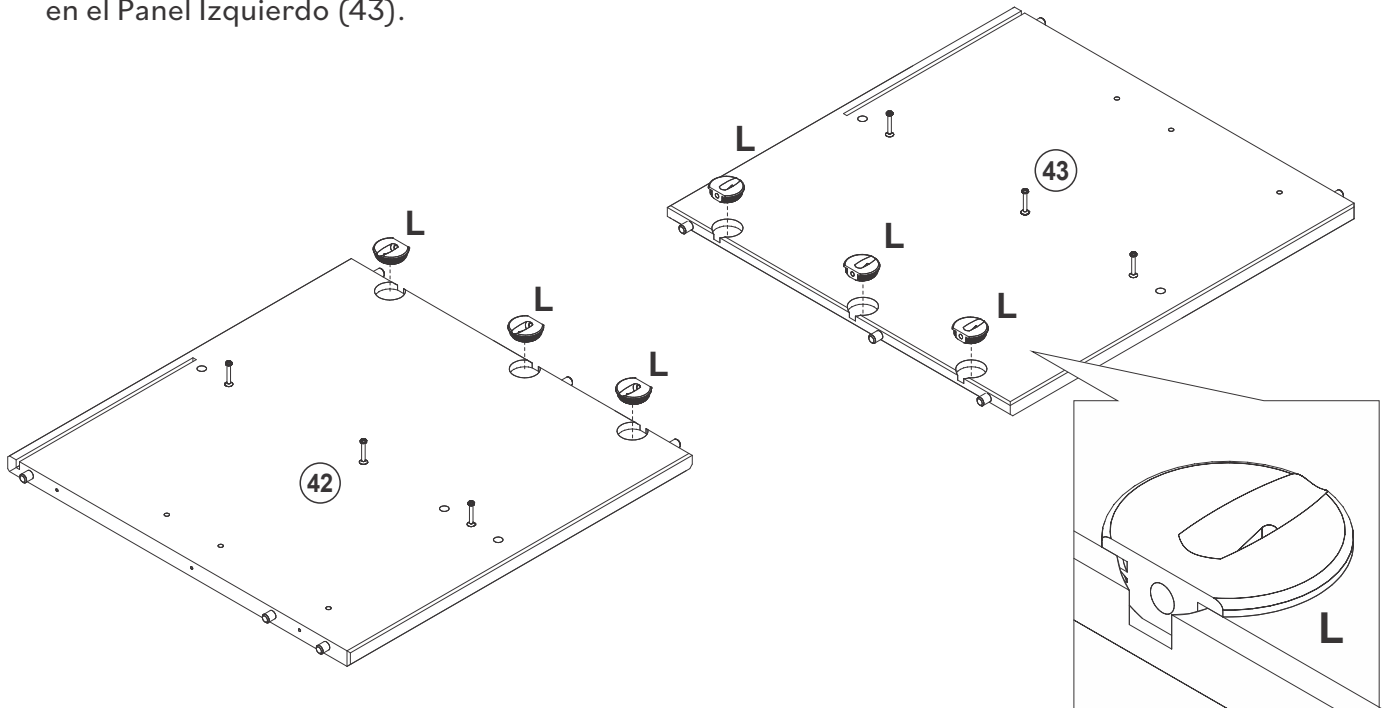
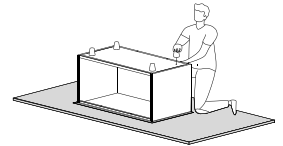

# Étape / Paso 4

(FR)

Fixez le Support Glissière Métallique R6 (O) sur le Panneau Droit (42) avec la Vis (F) et le tournevis Phillips.

(ES)

Fije el Soporte Corredera Metálica R6 (O) al Panel Derecho (42) con el Tornillo (F) y el destornillador Phillips.

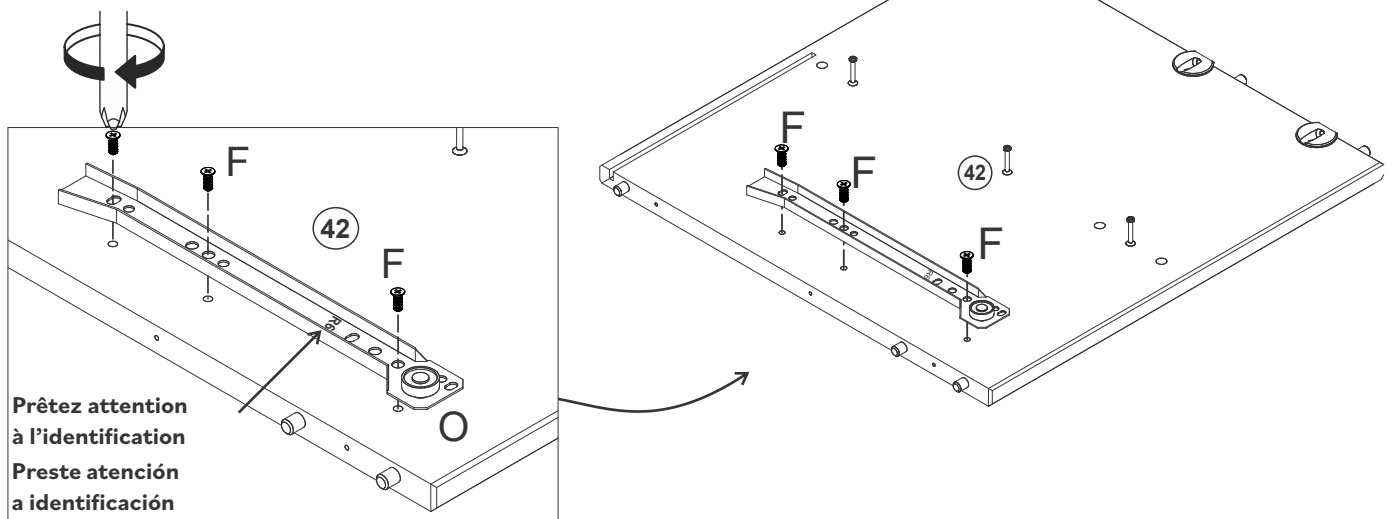

## Étape / Paso 5

(FR)

Fixez le Support Glissière Métallique L6 (P) sur le Panneau Gauche (43) avec les vis (F) et le tournevis Phillips.

(ES)

Conecte el Soporte Corredera Metálica L6 (P) al Panel Izquierdo (43) con el Tornillo (F) y el destornillador Phillips.

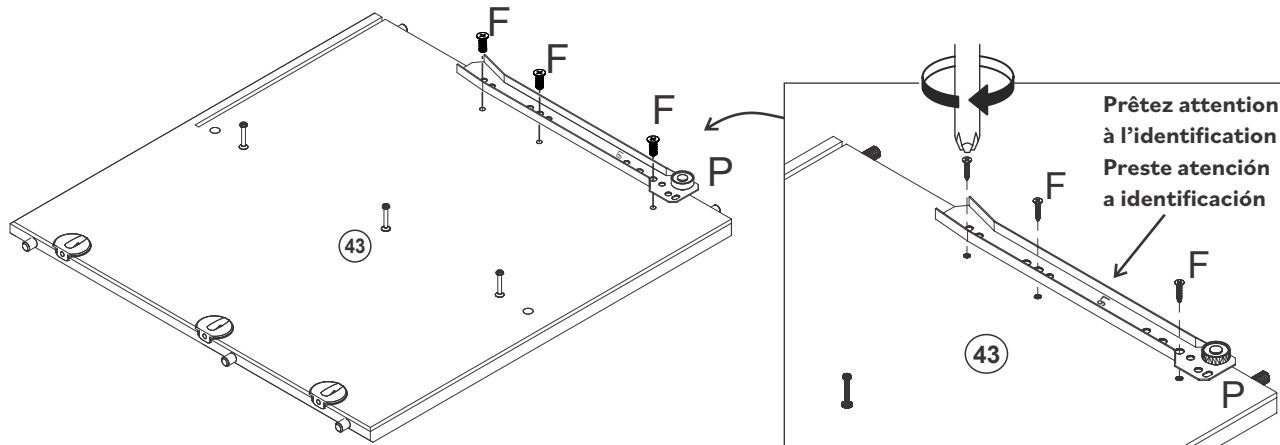
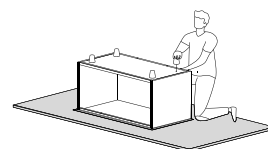

## Étape / Paso 6

(FR)

Utilisez un tournevis Phillips pour insérer la Vis (G) dans les Supports Glissières latérales droite et gauche.

(ES)

Utilice un destornillador Phillips para colocar el Tornillo (G) en los Soportes Correderas laterales derecha e izquierda.

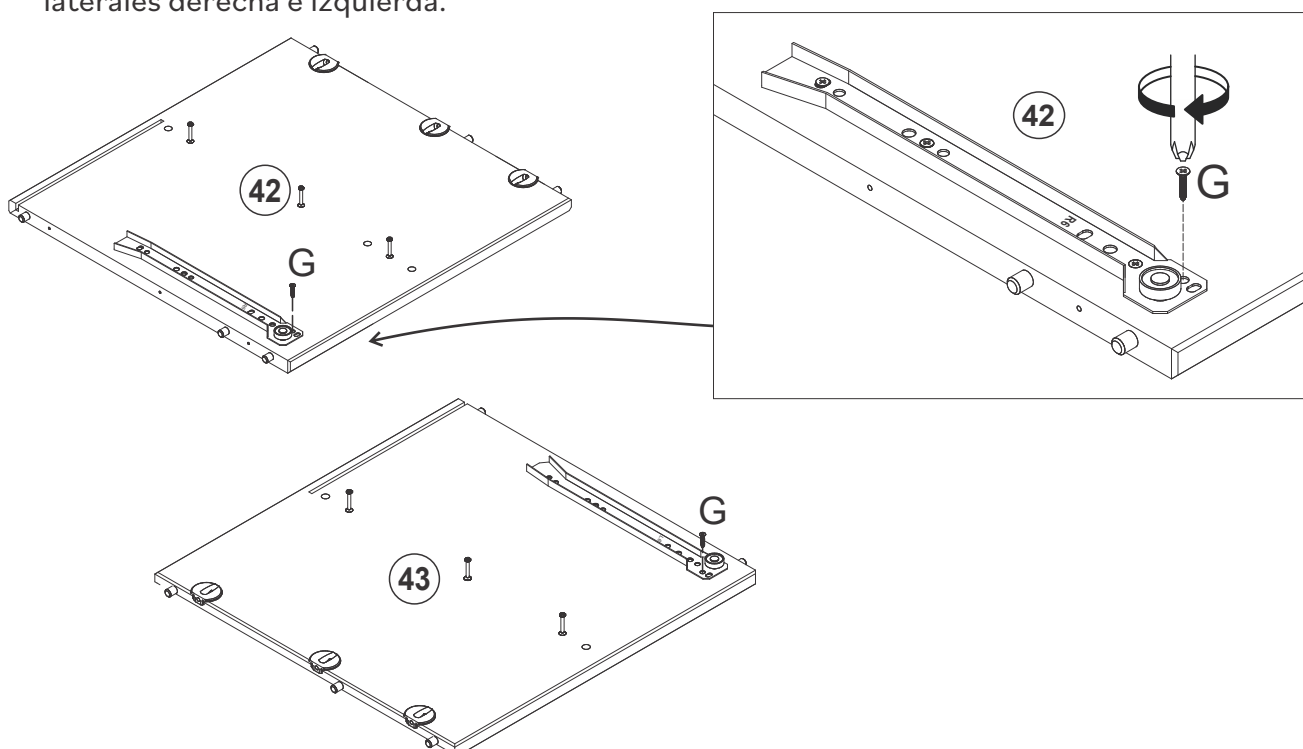

# Étape / Paso 7

(FR)

Attachez le Panneau Supérieur (45) sur le Panneau Droit (42). Insérez la Vis (B) dans le Dispositif de Fixation en Plastique (L) et serrez-la avec un tournevis Phillips.

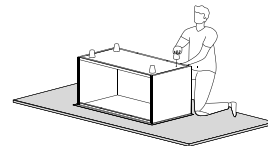

(ES)

Conecte el Panel Superior (45) al Panel Derecho (42). Inserte el Tornillo (B) en el Dispositivo de Fijación de Plástico (L) y apriételo con un destornillador Phillips.

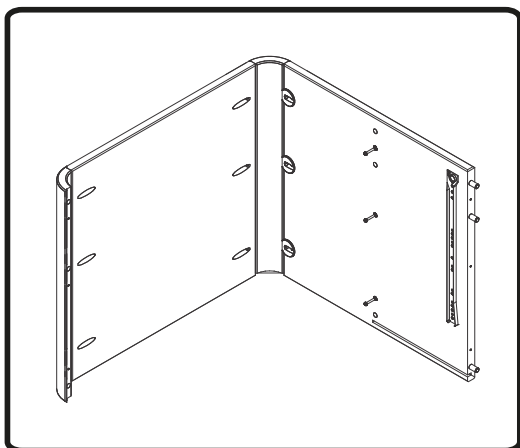
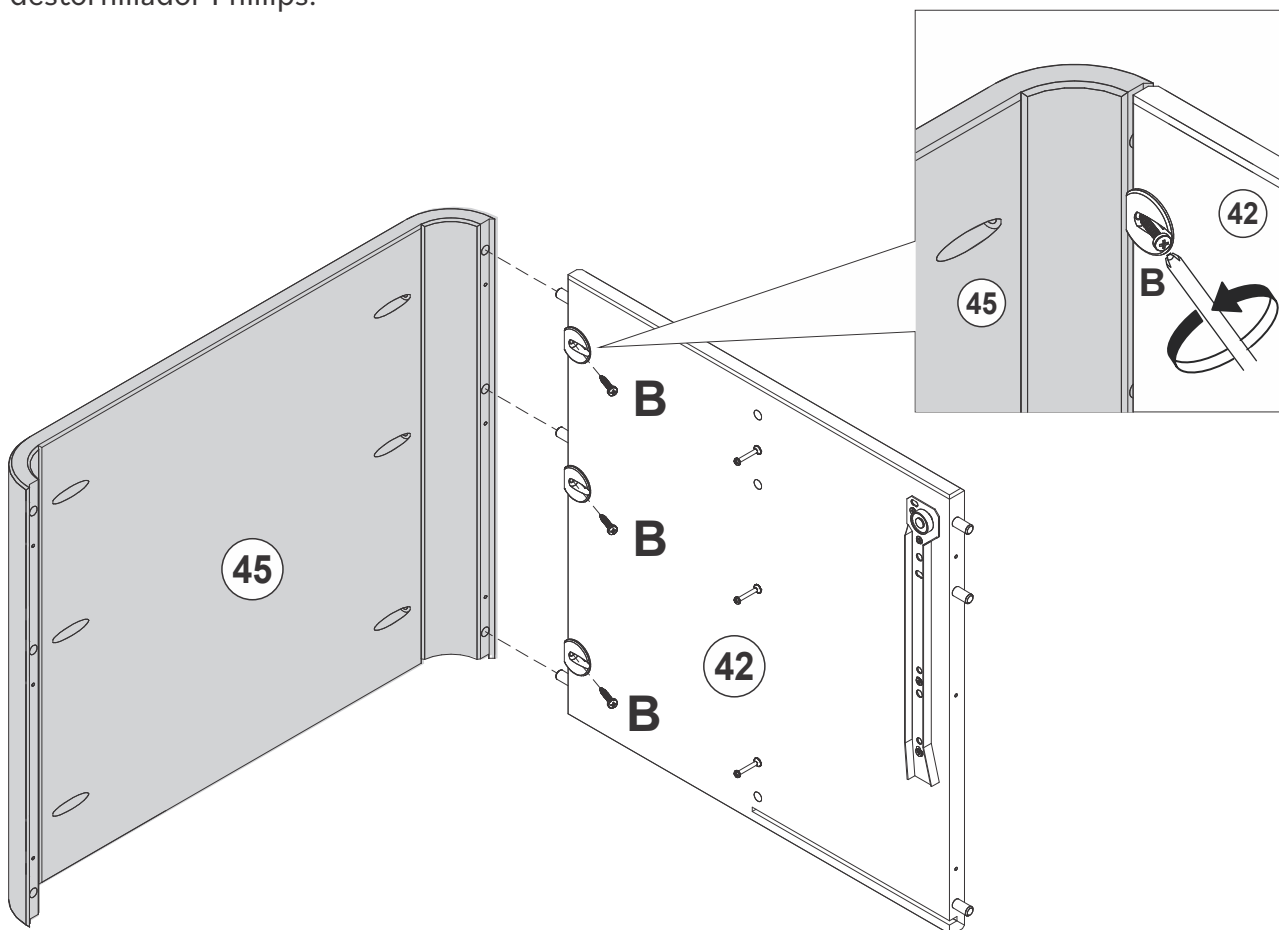

# Étape / Paso 8

(FR)

Attachez l'Étagère (25) sur le Panneau Droit (42). Insérez la Boitier de Assemblage (E) dans l'Étagère (25) et serrez avec un tournevis Phillips.

(ES)

Conecte el Estante (25) al Panel Derecho (42). Inserte la Traba del Conector (E) en el Estante (25) y apriételo con un destornillador Phillips.

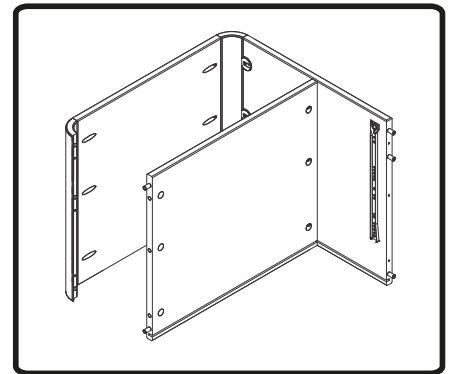
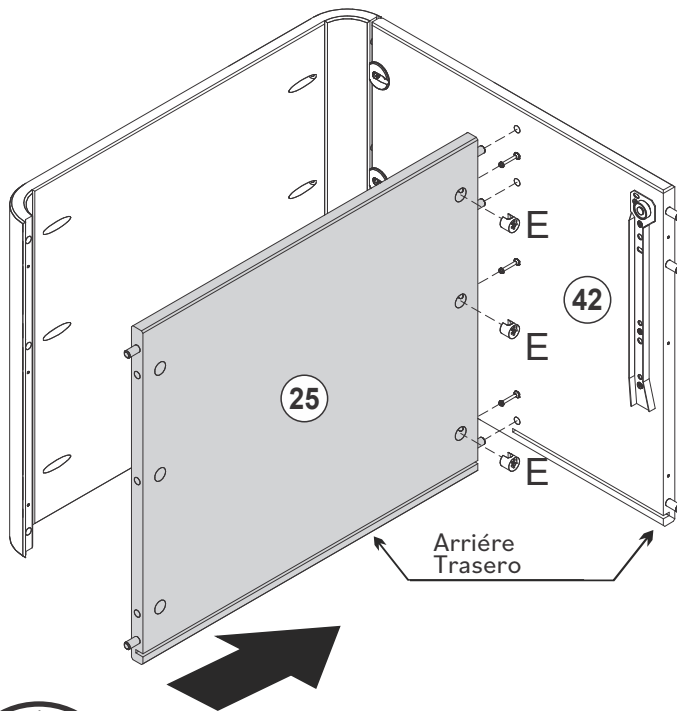
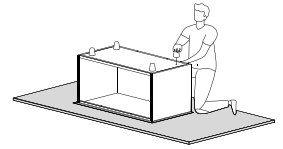

## Goujon de Assemblage

Goujon de Assemblage permet de joindre deux pièces en toute sécurité.

Suis ces étapes simples.

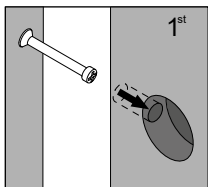

1: Insère le Goujon dans les orifices du côté plat. Ne serre pas trop !

1: Coloca el Conector en los orificios del lado plano. ¡No aprietes demasiado!

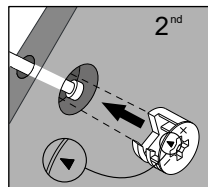

2: Joins les pièces en bois. Les Goujons entrent dans les orifices qui ont des trous sur les côtés, tu dois pouvoir voir les Goujons à travers ceux-ci. Après avoir installé les pièces, insère le Boitiers dans les orifices latéraux

2: Una las piezas de madera. Los Conectores entran en las piezas que tienen orificios en los lados, por lo que deberías poder ver los Conectores a través de ellos. Después de encajar las piezas, inserta la traba en los orificios laterales.

## Conector

Los Conector ayudan a unir de forma segura dos piezas. Sigue estas fáciles etapas.

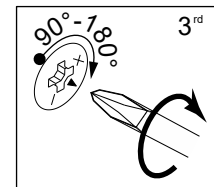

3: Sur la partie arrière du boitier, il aura la forme d'un « C ». Insère le boitier de manière à ce que l'ouverture « C » s'emboîte à la goujon. Serre-la avec le tournevis.

3: La parte posterior de la traba tendrá la forma de "C". Inserta el tambor de modo que la abertura de la "C" encaje en el Conector. Apriétalo con un destornillador.

## Étape / Paso 9

(FR)

Fixez le Panneau Gauche (43) au Panneau Supérieur (45) à l'aide des chevilles et des trous. Insérez les Goujons (I) dans les trous de l'étagère (25). Insérez le Boitier (E) dans l'Étagère (25) et serrez-les avec un tournevis Phillips.

(ES)

Conecte el Panel Izquierdo (43) al Panel Superior (45) usando las espigas y agujeros. Coloque los Conectores (I) en los agujeros del Estante (25). Inserte las Trabas (E) en el Estante (25) y apriételo con un destornillador Phillips.

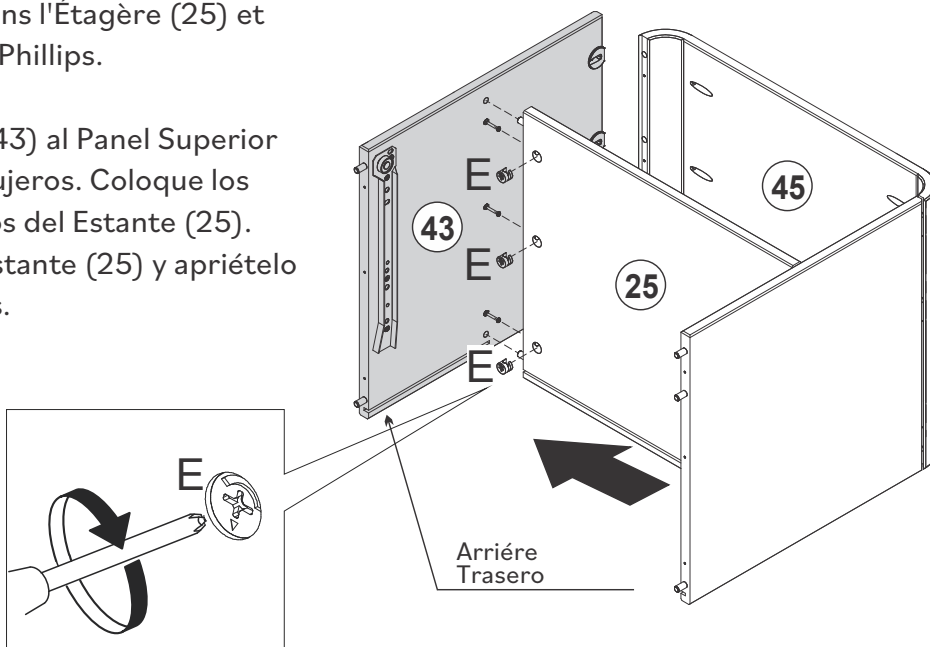
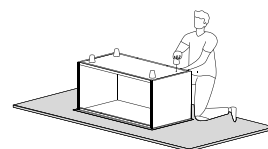

## Étape / Paso 10

(FR)

Attachez le Panneau Gauche (43) au Panneau Supérieur (45). Insérez la Vis (B) dans la fixation en plastique (L) et serrez-la avec un tournevis cruciforme.

(ES)

Conecte el Panel Izquierdo (43) al Panel Superior (45). Inserte el Tornillo (B) en la Fijación de plástico (L) y apriételo con un destornillador Phillips.

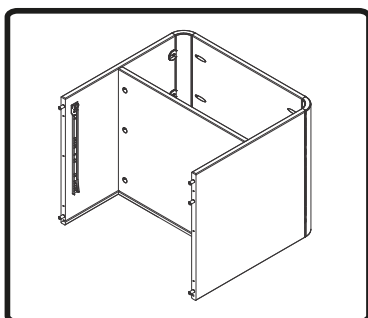
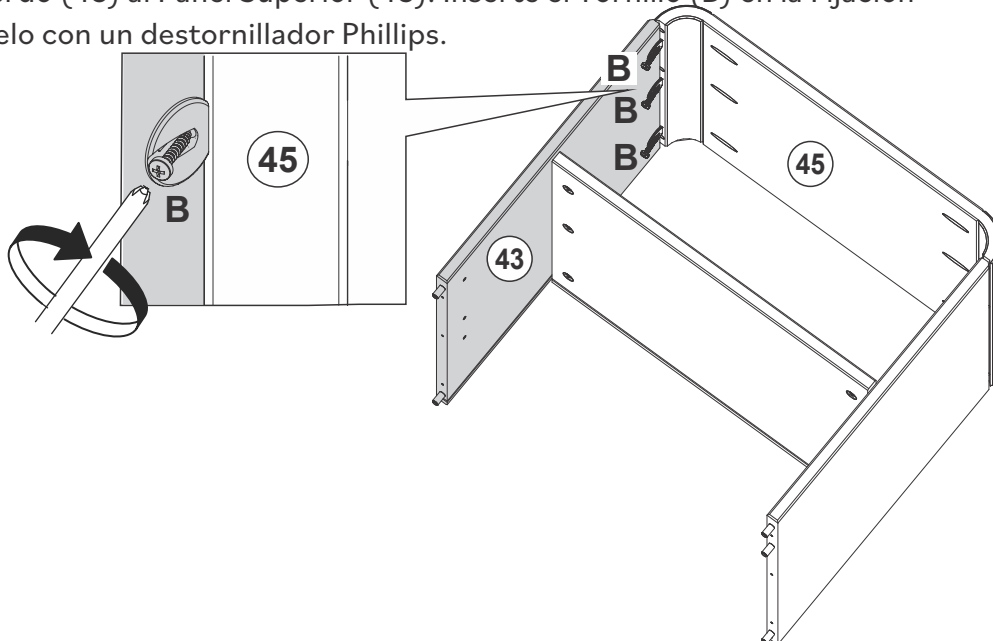



# Étape / Paso 11

(FR)

Insérez l'Arrière (07) entre le Panneau Droit (42) et le Panneau Gauche (43).

(ES)

Inserte la Parte Trasera (07) entre el Panel Derecho (42) y el Panel Izquierdo (43).

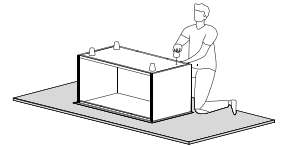

Nom et adresse du fournisseur et date de production

Nombre y dirección del proveedor y fecha de producción.

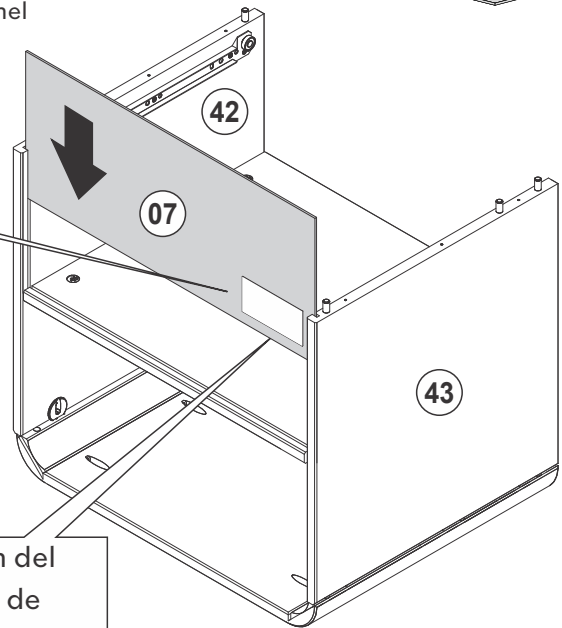
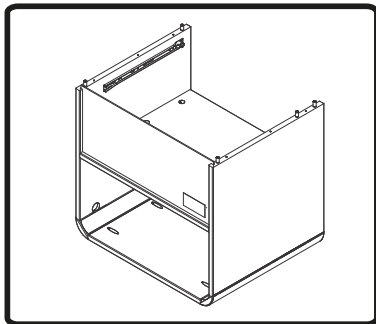

# Étape / Paso 12

(FR)

Insérez les Boulons (H) dans le Panneau Inférieur (24) et les Pieds (26), et serrez-la avec la clé Allen (K).

(ES)

Inserte el Perno (H) en el Panel Inferior (24) y los Pies (26) y apriételo con la llave Allen (K)

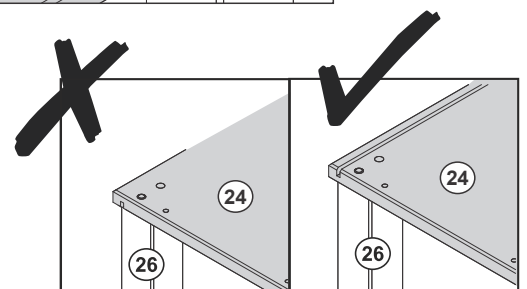
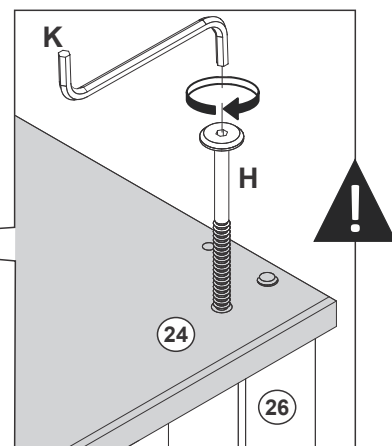
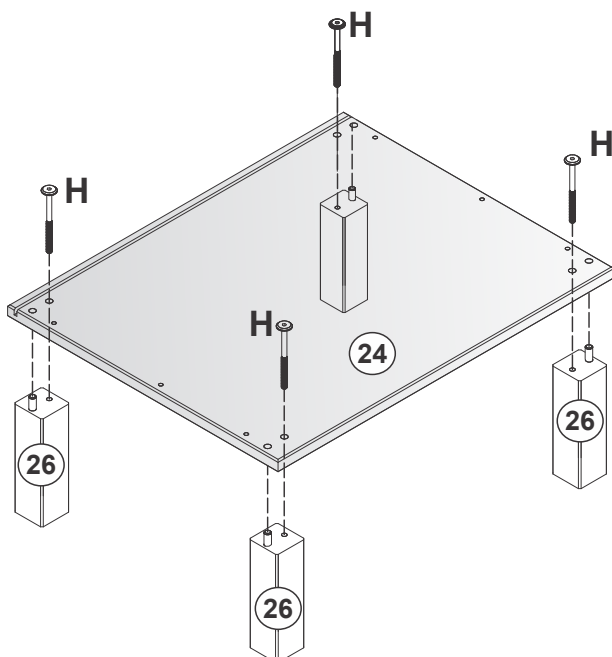

# Étape / Paso 13

(FR)

Fixez le Panneau Inférieur(24) au Panneau Droit (42) et au Panneau Gauche (43) avec la Vis (D) et serrez-la avec un tournevis Phillips.

(ES)

Conecte el Panel Inferior (24) al Panel Derecho (42) y al Panel Izquierdo (43) con el Tornillo (D) y apriételo con un destornillador Phillips.

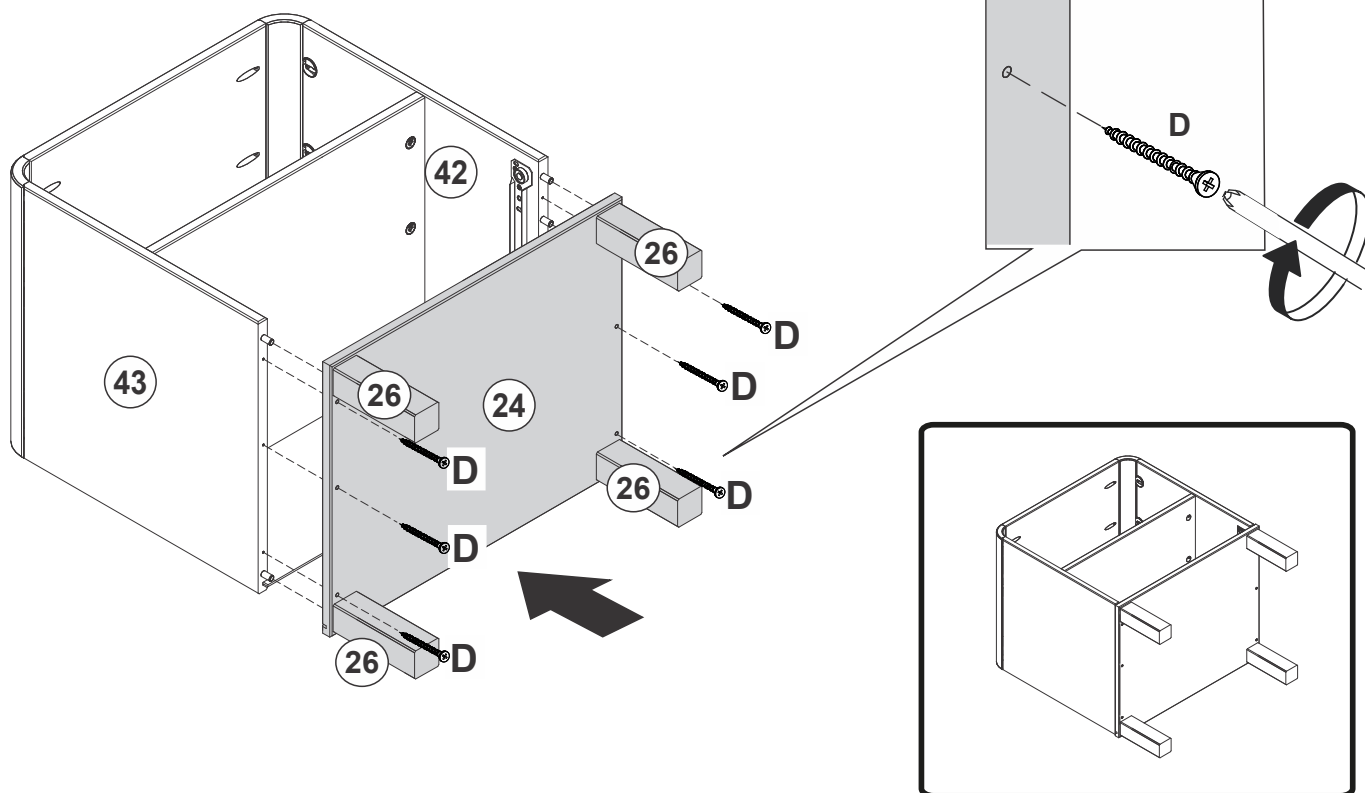
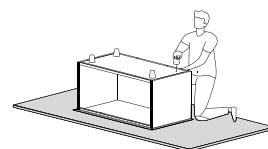

# Étape / Paso 14

(FR)

Retirez l'autocollant en feutre du papier. Collez la feutrine sous le pied.

(ES)

Retire la pegatina de fieltro del papel. Pega el fieltro a la planta del pie

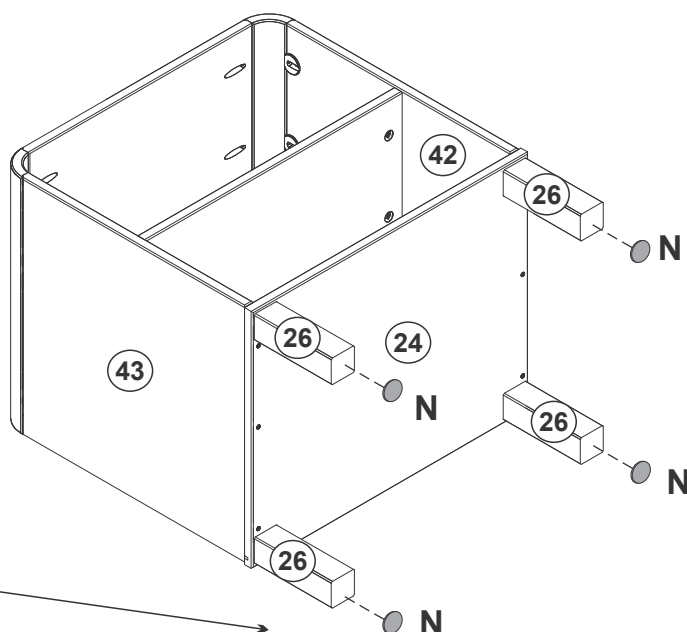
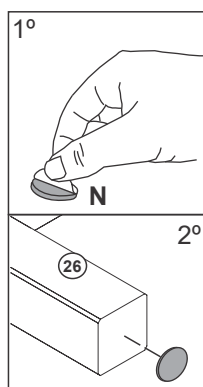

# Étape / Paso 15

(FR)

Fixez le Côté Gauche du tiroir (29) et le Côté Droit du tiroir (30) à la Façade du tiroir (44) à l'aide de la Vis (E) et serrez-le avec un tournevis Phillips.

(ES)

Conecte el Lado Izquierdo del Cajón (29) y el Lado Derecho del Cajón (30) al Frente del Cajón (44) usando el Tornillo (E) y apriételo con un destornillador Phillips.

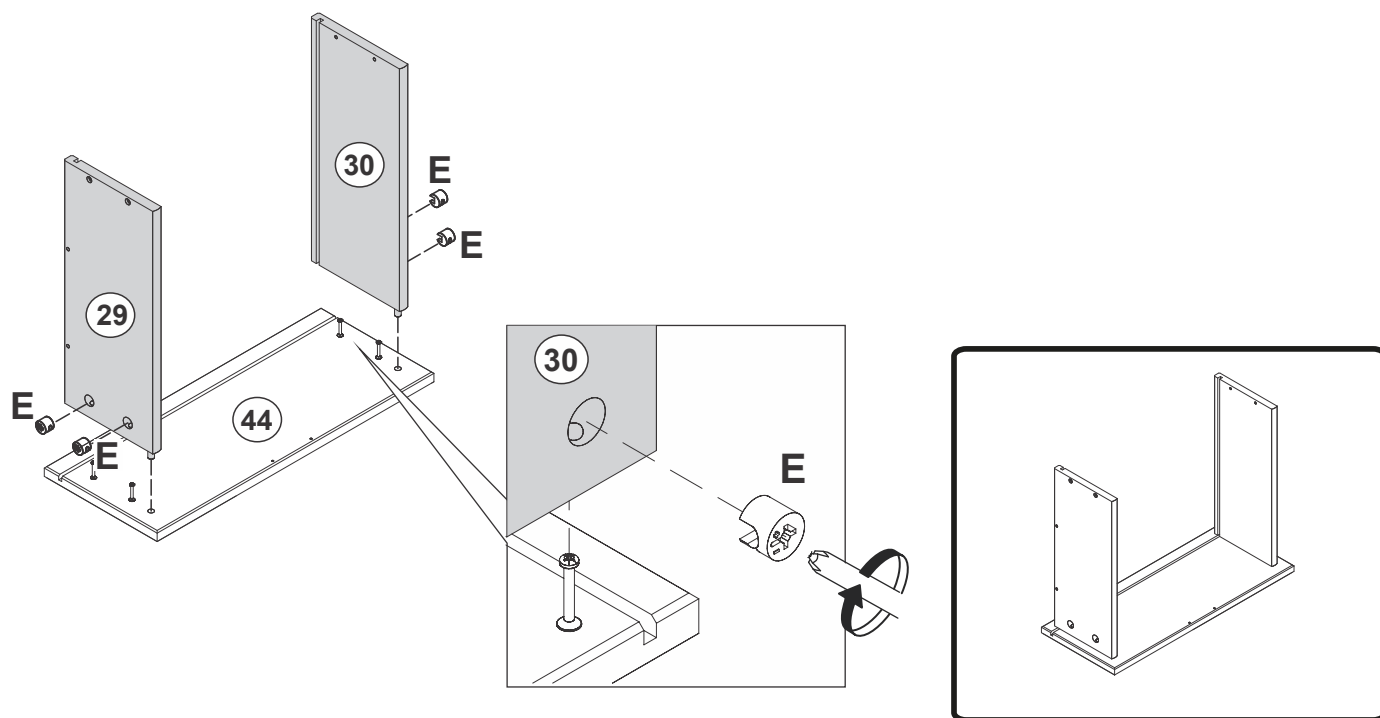
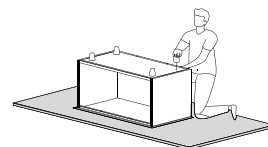

# Étape / Paso 16

(FR)

Insérez le Fond du tiroir (27) entre le Côté Gauche du tiroir (29) et le Côté Droit du tiroir (30).

(ES)

Inserte el Inferior del Cajón (27) entre el Lado Izquierdo del Cajón (29) y el Lado Derecho del Cajón (30).

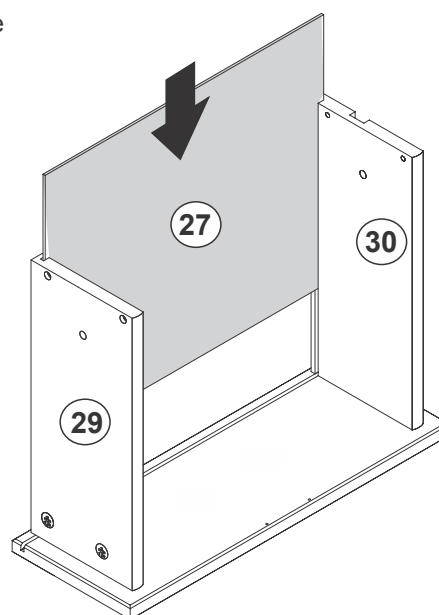

# Étape / Paso 17

(FR)

Insérez l'Arrière du tiroir (46) entre le Côté gauche du tiroir (29) et le Côté droit du tiroir (30). Fixez l'Arrière du tiroir (46) au Côté Gauche du tiroir (29) et au Côté Droit du tiroir (30) avec la vVs (C) et un tournevis Phillips.

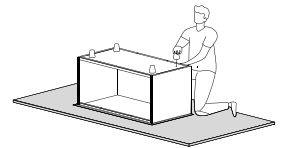

(ES)

Inserte la Parte Trasera del Cajón (46) entre el Lado Izquierdo del Cajón (29) y el Lado Derecho del Cajón (30). Conecte la Parte Trasera del Cajón (46) al Lado Izquierdo del Cajón (29) y al Lado Derecho del Cajón (30) con el tornillo (C) y un destornillador Phillips.

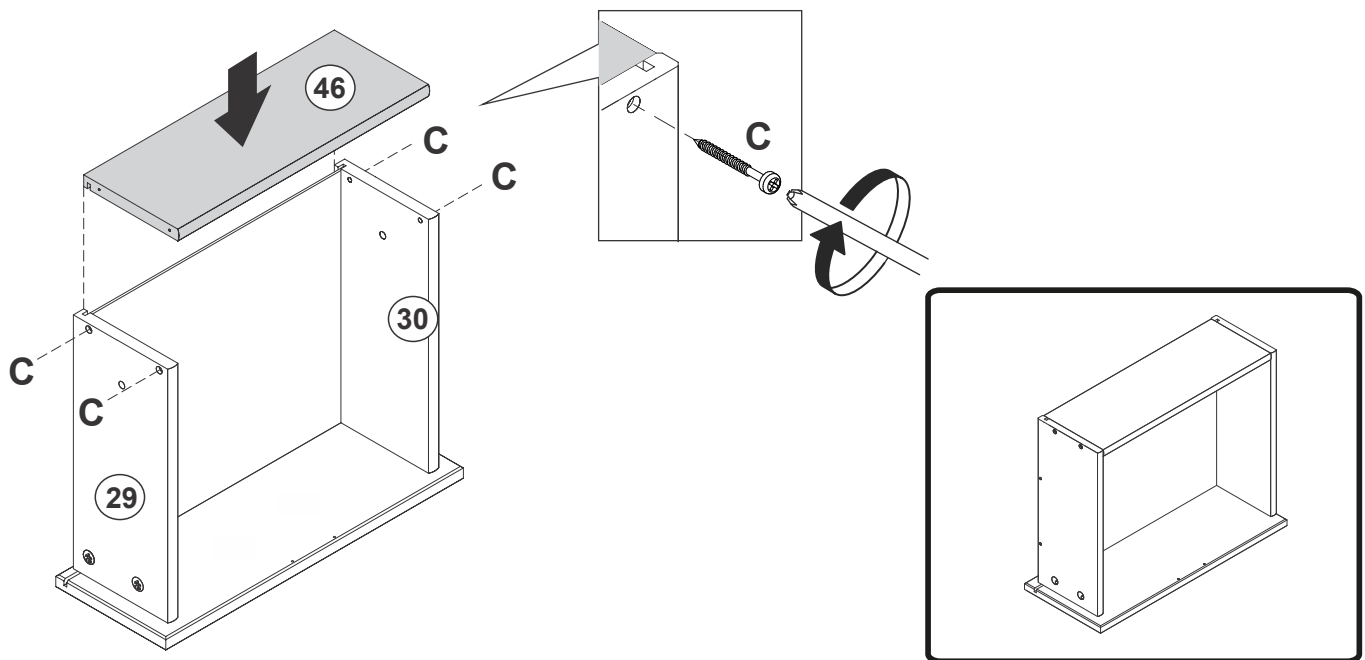

# Étape / Paso 18

(FR)

Fixez la poignée (J) avec la vis (G) et un tournevis cruciforme.

(ES)

Asegure la manija (J) con el tornillo (G) y un destornillador Phillips.

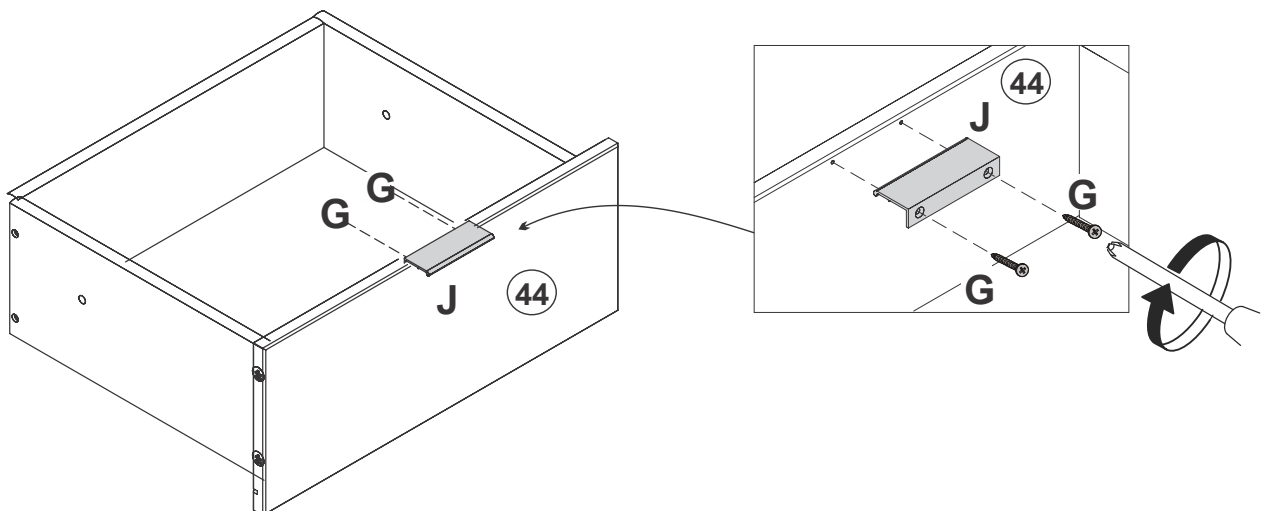

# Étape / Paso 19

(FR)

Fixez la Glissière Droit (Q) sur le Côté Droit du Tiroir (30) avec la Vis (F), serrez-la avec un tournevis Phillips. Fixez la Glissière Gauche (R) sur le Côté Gauche du Tiroir (29) avec la Vis (F), serrez-le avec un tournevis cruciforme.

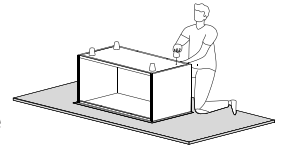

(ES)

Coloque la Corredera Derecha (Q) en el Lado Derecho del Cajón.

(30) con el Tornillo (F), apriételo con un destornillador Phillips. Coloque la Corredera Izquierda (R) en el Lado Izquierdo del Cajón (29) con el Tornillo (F), apriételo con un destornillador Phillips.

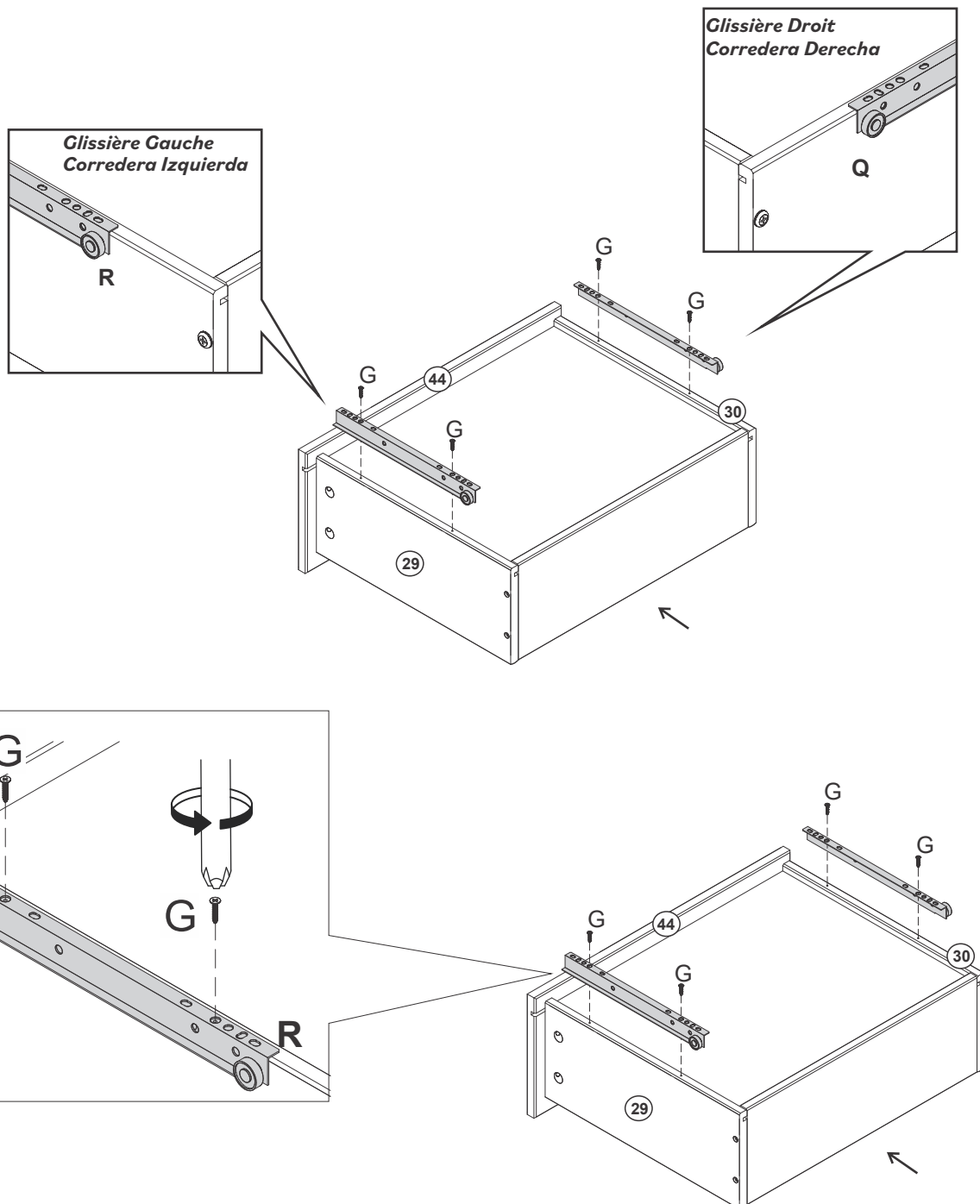

# Étape / Paso 20

(FR)

Insérez le cache (M) dans le Dispositif de Fixation en Plastique (L) sur le Panneau Droit (42) et le Panneau Gauche (43).

(ES)

Inserte la Tapa (M) en el Dispositivo de fijación de plástico (L) en el Panel Derecho (42) y el Panel Izquierdo (43).

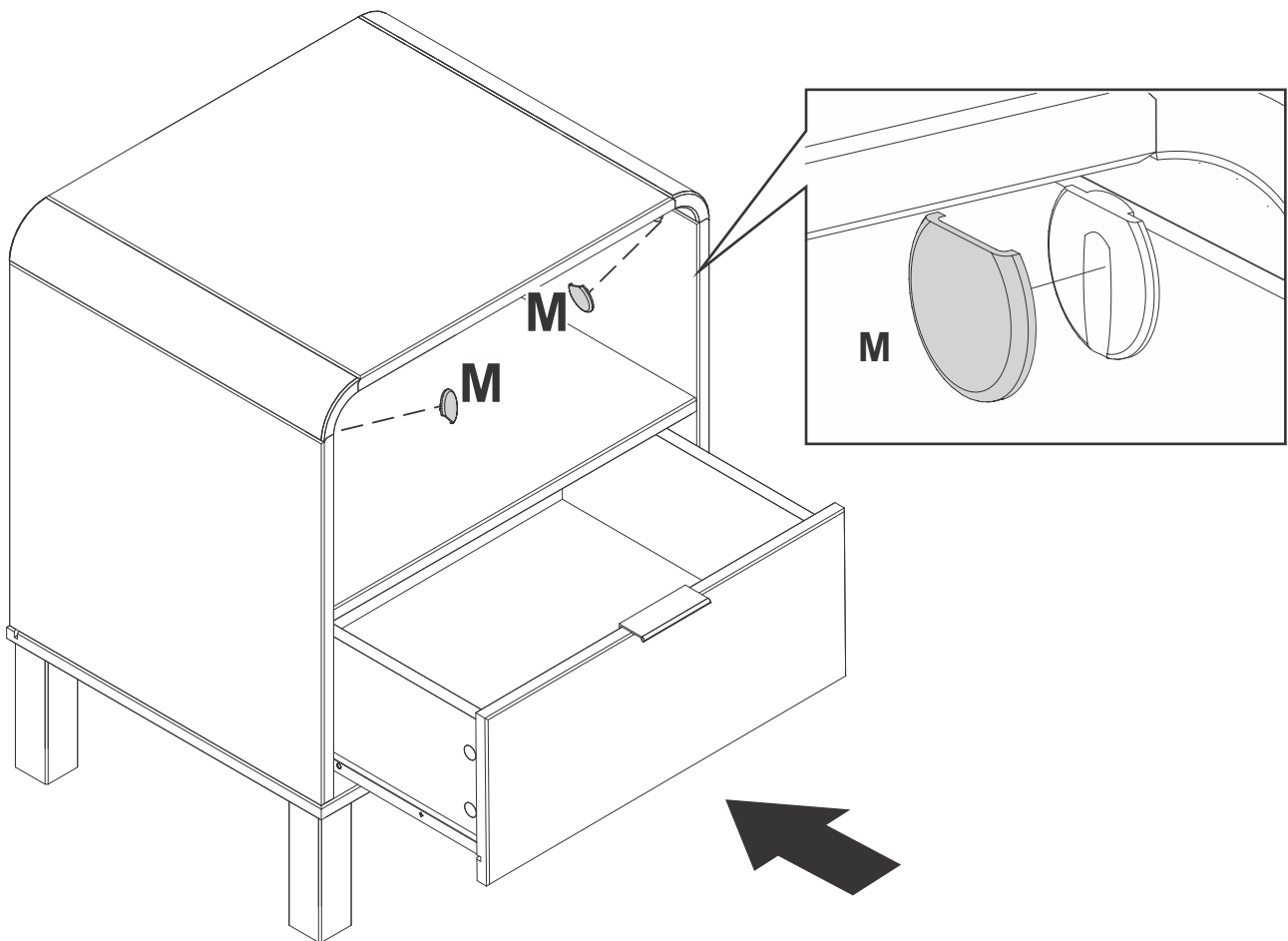
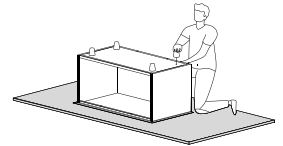

- 1 - Insérez la glissière droite (Q) dans le support de glissière droit (O)
  - 2 - Insérez la glissière gauche (R) dans le support de glissière gauche (P).
- 1 - Coloque la corredera derecha (Q) en el soporte de la corredera derecha (O)
  - 2 - Coloque la corredera izquierda (R) en el soporte de la corredera izquierda (P)

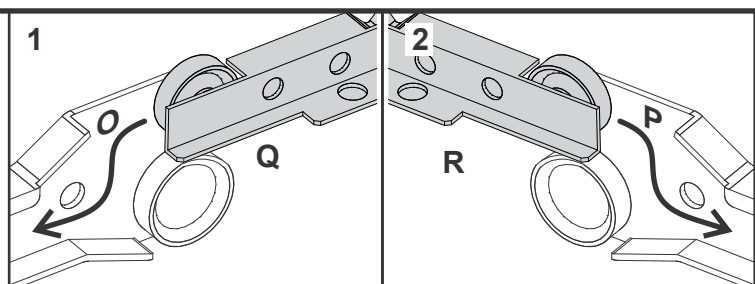

Vous avez réussi ! Profitez de votre nouvelle table de chevet !  
Lo has conseguido! Disfruta de tu nueva mesita de noche !

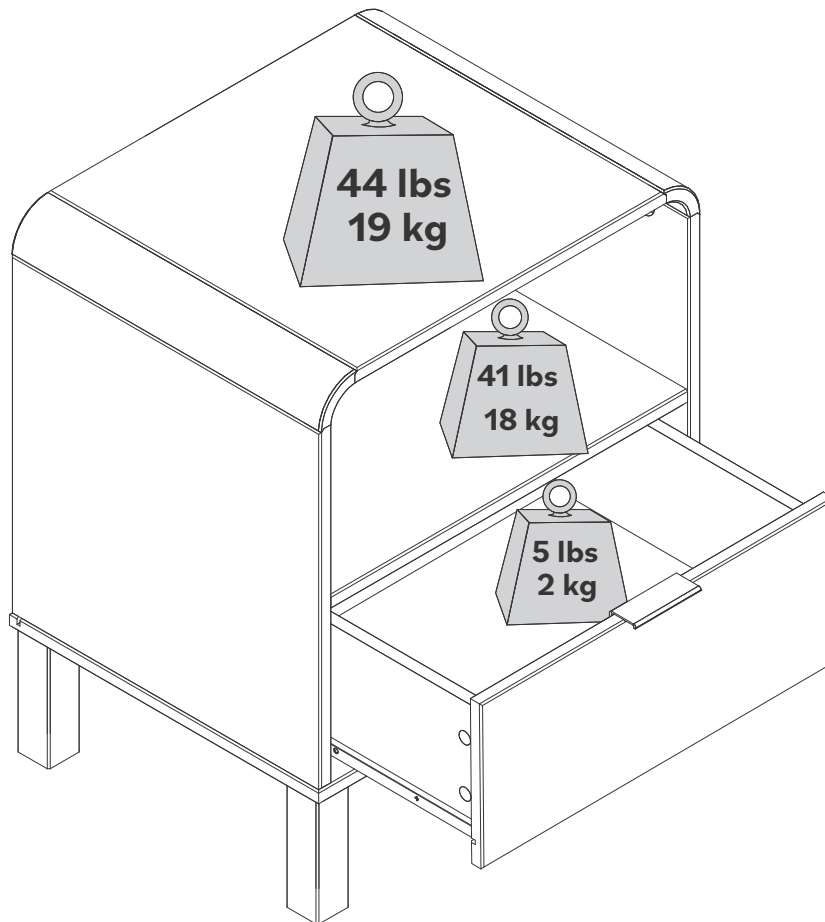

Félicitations pour votre nouveau meuble!  
Nous serions ravis d'en entendre parler et de le voir.  
Laissez-nous un commentaire ou postez une photo  
avec le mot-clé #mywalkerredisonhome

Enhorabuena por su nuevo mueble!  
Nos encantaría conocerlo y verlo.  
Por favor, déjenos un comentario o  
publique una foto con #mywalkerredisonhome

## Assembler des meubles peut parfois être compliqué.

Notre équipe de service client, située dans l'Utah, est là pour obtenir des informations sur les produits, aider pour l'assemblage d'un produit ou pour tout autre problème de support client.

Appelle-nous **801-433-3008**

Envoie-nous les e-mails à **service@walkeredison.com**

Visite notre site accueil au client à

**walkeredison.com/pages/customer-service**

Nous sommes disponibles pour t'aider du Lundi au Jeudi de 8 am - 5 pm, Vendredi de 8 am - 3 pm MST.

Pour plus de détails sur les vidéos d'assemblage, les instructions d'assemblage, les pièces de rechange et le service client.

**NUMÉRISER ICI.**



Pour le nettoyage, n'utilise jamais d'abrasifs, utilise un chiffon doux et de l'eau avec du savon neutre pour nettoyer les meubles

## Assembler des meubles peut parfois être compliqué.

Notre équipe de service client, située dans l'Utah, est là pour obtenir des informations sur les produits, aider pour l'assemblage d'un produit ou pour tout autre problème de support client.

Appelle-nous **801-433-3008**

Envoie-nous les e-mails à **service@walkeredison.com**

Visite notre site accueil au client à

**walkeredison.com/pages/customer-service**

Nous sommes disponibles pour t'aider du Lundi au Jeudi de 8 am - 5 pm, Vendredi de 8 am - 3 pm MST.

Pour plus de détails sur les vidéos d'assemblage, les instructions d'assemblage, les pièces de rechange et le service client.

**NUMÉRISER ICI.**



Pour le nettoyage, n'utilise jamais d'abrasifs, utilise un chiffon doux et de l'eau avec du savon neutre pour nettoyer les meubles