

SILVERBACK

MODEL NO.

B5400

SB54ig

BASKETBALL SYSTEM

OWNER'S MANUAL

1. **Read this manual carefully before starting assembly.** Read each step completely before beginning each step.
2. **Some smaller parts may be shipped inside larger parts. Check inside all parts and cartons before assembling or ordering parts.**
3. **To make assembly of your basketball system easier, use the Hardware Identifier on page 4 to identify and sort all fasteners. Check all cartons for kits. All hardware is not located in one kit.**
4. **Do not tighten hardware until instructed to do so.** If hardware is tightened too soon, mounting holes may not align and parts may not easily fit together. Leave locknuts slightly loose until you are instructed to tighten them.
5. An electric screwdriver is helpful in assembly. However, please **set at low torque and use caution** because you could overtighten the hardware and strip the screws.
6. **Save these instructions and your proof of purchase (receipt) in the event that the manufacturer has to be contacted for replacement parts.**

Please Do Not Return This Product To the Store

Contact Escalade® Sports customer service department at:

Phone: 1-800-USA-GOAL Toll – Free !

Fax: 1-866-873-3536 Toll – Free !

E-mail: basketball@escaladesports.com

Escalade Sports

Physical Location: Mailing Address: (Correspondence Only)

817 Maxwell Ave. PO Box 889

Evansville, IN 47711 Evansville, IN 47706

ITEMS NEEDED (not included)

- 9- 50 lbs bags of concrete
(2-3 extra bags recommended)
- 1- Post hole digger (optional)
- 1- Wheel barrow
- 1- Garden hose
- 1- Level
- 1- Tape Measure
- 6- 2X4's
- 2- 50 lbs sand bags
- 1- Standard masonry block
- 1- 9/16", 3/4" & adjustable wrench
- 1- Cordless drill & 9/64" drill bit
- 1- 5/16" socket driver (for cordless drill)
- 1- Pair of Safety Glasses
- 1- Phillips Screwdriver
- 1- Ladder
- 1- Piece of Plywood or Mdf
(see Figure 3 on Page 6)

Please visit our Website at: www.escaladesports.com

ON-LINE TROUBLE SHOOTING

TECHNICAL ASSISTANCE

ON-LINE PARTS REQUESTS

FREQUENTLY ASKED QUESTIONS

ADDITIONAL ESCALADE® SPORTS PRODUCT INFORMATION

ESCALADE®

S P O R T S

2L-7196-06

Escalade® Sports products may be manufactured and/or licensed under the following patents:
6419596, 6179733, 5919102, 5071120, 4798381, 4424968, D326128, 7244046

Additional patents may be pending. One or more of the listed patents and/or pending patents may cover specific product.

©2025 Escalade® Sports



WARNING

FAILURE TO FOLLOW THESE WARNINGS MAY RESULT IN SERIOUS INJURY AND/OR PROPERTY DAMAGE.

Owner must ensure that all players know and follow these rules for safe operation of the system.

- DO NOT DUNK on this system.
- DO NOT HANG on the rim or any part of system including backboard, support braces or net.
- During play, keep players face away from the backboard, rim, and net. Serious injury could occur if teeth/face encounter backboard, rim, or net.
- Wear a mouthguard when playing to avoid dental injuries.
- Do not slide, climb, or play on pole.
- During Play, do not wear jewelry (rings, watches, necklaces, etc.). Objects may entangle in net or other areas of structure.
- Do not allow children to adjust system.
- When adjusting height, keep hands and fingers away from moving parts.
- Keep water and organic material away from pole. Pole can rust and fail.
- Check system BEFORE EACH USE for loose hardware, instability and signs of corrosion and repair before each use. Never play on damaged equipment.
- Once a month check pole and all metal parts for rust. Completely remove rust and repaint with exterior enamel. If rust has penetrated any steel part, replace that part immediately.
- Do not use this system to lift or hoist anything. The mechanism is designed to lift only the weight of the backboard and rim. Do not hang anything from the handle, rim, backboard, or lifter arms as this will damage the system and void the warranty.
- Refer to product manual for assembly instructions.

4L-7609-01

SAFETY INSTRUCTIONS

FAILURE TO FOLLOW THESE SAFETY INSTRUCTIONS MAY RESULT IN SERIOUS INJURY, PROPERTY DAMAGE AND WILL VOID WARRANTY.

Owner must ensure that all players know and follow these rules for safe operation of the system.

To ensure safety, do not attempt to assemble this system without following the instructions carefully. Proper and complete assembly, use and supervision is essential for proper operation and to reduce the risk of accident or injury. A high probability of serious injury exists if this system is not installed, maintained, and operated properly.

- If using a ladder during assembly, use extreme caution.
- 4 people are recommended for this operation.
- Seat the pole sections properly (if applicable). Failure to do so could allow the pole sections to separate during play.
- Before digging contact utility company to locate underground power cables, gas and water lines. Ensure there are no overhead power lines within 20 ft. (7m) radius of pole location.
- Climate, corrosion or misuse could result in system failure.
- If technical assistance is required, contact the manufacturer.
- Minimum operational height is 6'6" (1.98m) to the bottom of backboard.

*Most injuries are caused by misuse and/or not following instructions.
Use caution when using this system.*





WARNING

FAILURE TO FOLLOW THESE WARNINGS MAY RESULT IN SERIOUS INJURY AND/OR PROPERTY DAMAGE.

- DO NOT DUNK on this system.
- During play, do not wear jewelry (rings, watches, necklaces, etc.) Objects may entangle in net or other areas of structure.
- Wear mouth guard during playing to avoid dental injuries.
- Do not allow children to adjust the system.
- See pole for additional warnings.

 <h1 style="margin: 0;">WARNING</h1>
<p>DO NOT DUNK ON THIS UNIT . DO NOT HANG FROM ANY PART OF THIS UNIT , INCLUDING THE BACKBOARD, RIM, SUPPORT BRACES OR NET.</p>
<p>4L-8152-01</p>

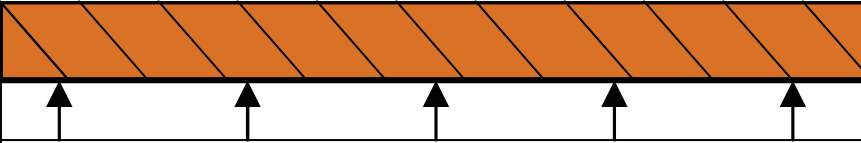
(Affixed to Top Post)

<p>Bottom of upper pole must cover the above orange portion of this sticker (6" mark).</p>
 <h1 style="margin: 0;">WARNING</h1>
<p>FAILURE TO FULLY ENGAGE THE BOTTOM OF THE UPPER POLE TO THE 6" MARK ON THIS BOTTOM POLE STICKER, COULD CAUSE YOUR UNIT TO COLLAPSE AND MAY RESULT IN SERIOUS INJURY OR PROPERTY DAMAGE.</p>
<h2 style="margin: 0;">BACKSIDE</h2>
<p>4L-8151-00</p>

(Affixed to Bottom Post)

BASKETBALL SYSTEM'S HARDWARE IDENTIFIER

Note: Check all cartons for hardware. All hardware is not packed in one kit.

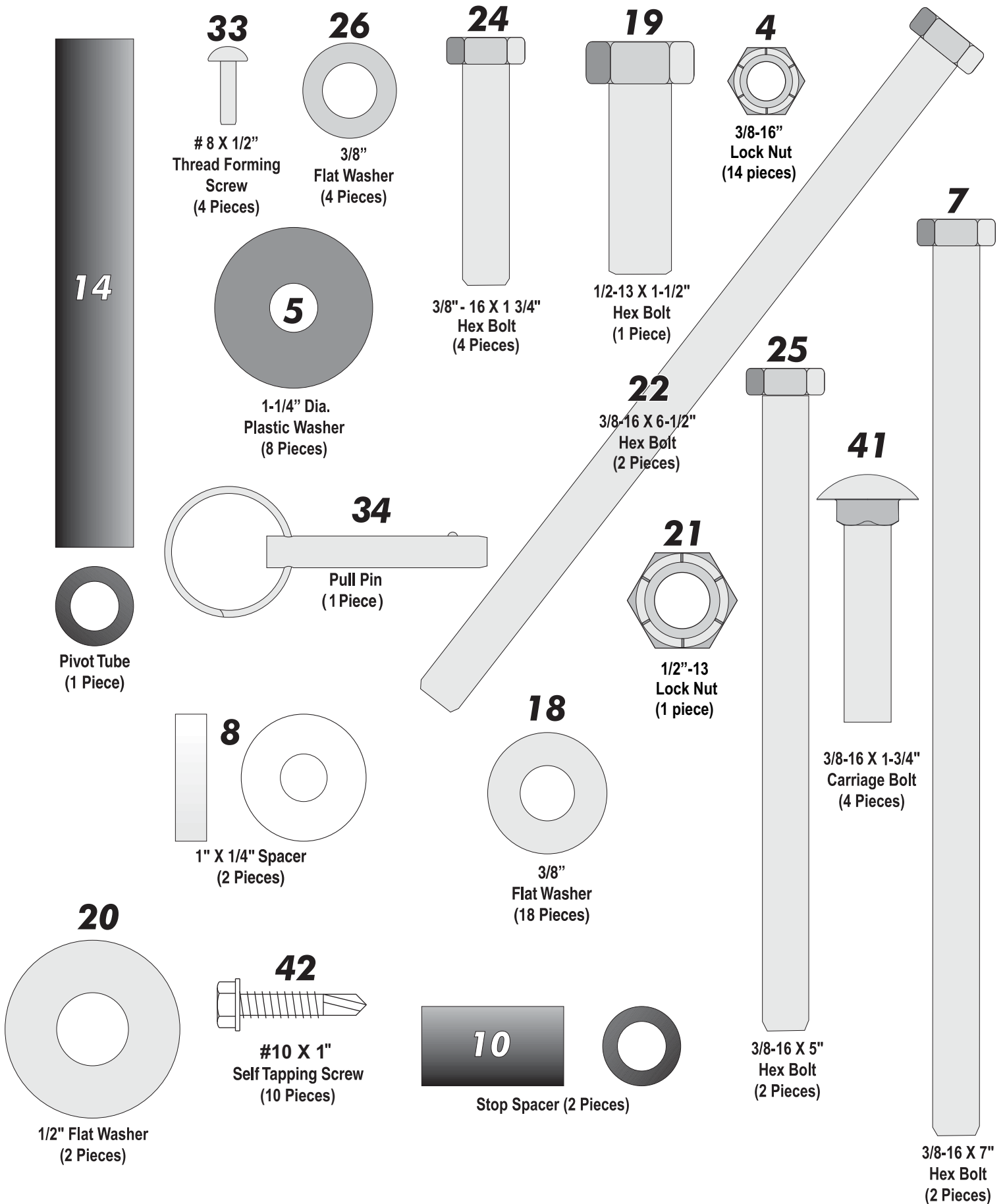

INSTALLATION TIMELINE

1. Prior to pole installation and goal assembly, call utility services for location of underground utility lines before you dig.
2. Vertical main post assembly is a two part process.

PART 1

- Day 1.** Post assembly, pour concrete, set post and Allow concrete to cure.
- Day 2.** Allow concrete to cure.

PART 2

- Day 3.** Complete assembly instructions. (Requires 3-4 adults)

POST INSTALLATION INSTRUCTIONS (Day 1)

⚠ DANGER ⚡

Before digging hole for anchor system, check for buried power, gas, water, and telecommunication lines! Failure to do so could result in serious or fatal injury! Contact your local utility company if unsure.

ITEMS NEEDED (not included)

- 9- 50 lbs bags of concrete (2-3 extra bags recommended)
- 1- Post hole digger (optional)
- 1- Wheel barrow
- 1- Garden hose
- 1- Level
- 1- Tape Measure
- 6- 2X4's
- 2- 50 lbs sand bags
- 1- Standard masonry block
- 1- 9/16", 3/4" & adjustable wrench
- 1- Cordless drill & 9/64" drill bit
- 1- 5/16" socket driver (for cordless drill)
- 1- Pair of Safety Glasses
- 1- Phillips Screwdriver
- 1- Ladder

Note: For best results with less vibration, your system should be independent of court. If pouring concrete for both at same time, add an expansion joint in between.

Note: When digging hole, if you hit rock and cannot dig through contact a contractor.

1. Determine the location of the hole. The proper location is as close to the court without making contact, as shown in **Figure 1**. This, however, is a general rule. If you need to locate the hole in a location other than this, use the following dimensions as a guide.

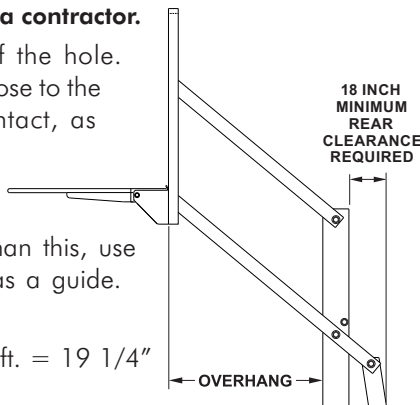

Overhang when adjusted to 10 ft. = 19 1/4"

Note: Minimum of 18" rear clearance is required behind pole.

2. Dig a round hole 32" deep and 16" in diameter at the top and 20" in diameter at the bottom of the hole. If you live in an area where frost heaves may pose a problem, consult your local building inspector to determine the proper hole depth. See **Figure 1**.

Figure 1

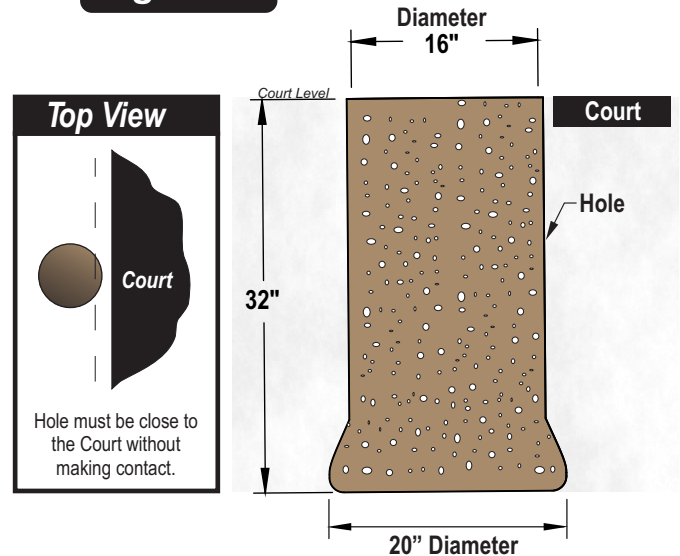

3. Place and center a masonry block in the bottom of the hole so there is exactly 16" from the playing surface to the top of the masonry block. See **Figure 2**.

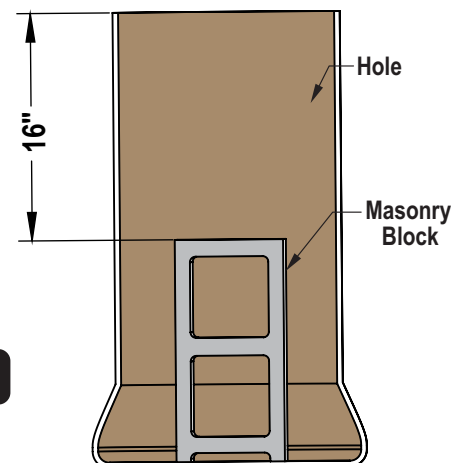

Figure 2

POST ASSEMBLY INSTRUCTIONS

1. Before putting any of the poles tubes together, make sure that the orange area of the Warning Sticker on Pole (#2) is 6 inches from the top end. **Be sure that the "Back Side" stickers are at the back of the pole.** See Figure 3A.

Figure 3B

WARNING
KEEP FEET AWAY WHEN SLAMMING POLE.

NOTE: When slamming poles together make sure to keep the poles **STRAIGHT**.

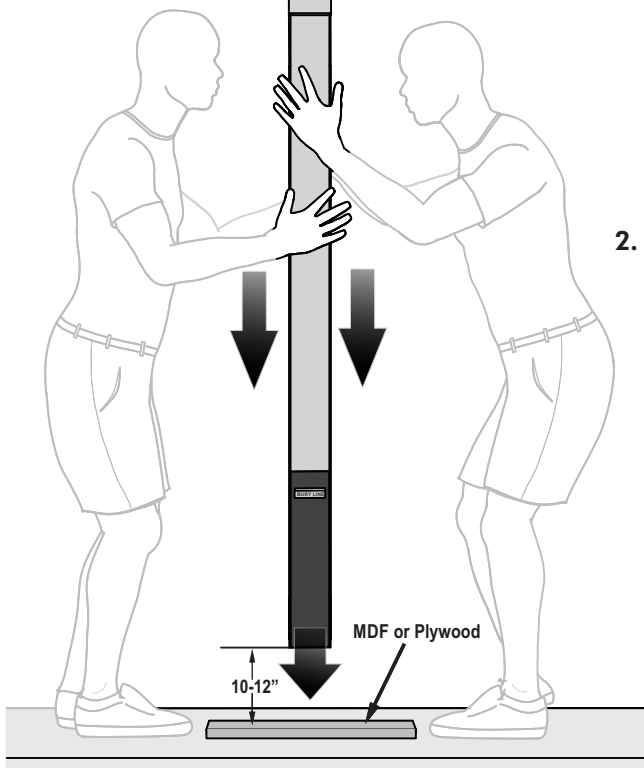

NOTE: When Slamming the pole together make sure you place the MDF or Plywood on a **flat surface** like concrete or Asphalt, do not slam pole on grass or soft ground.

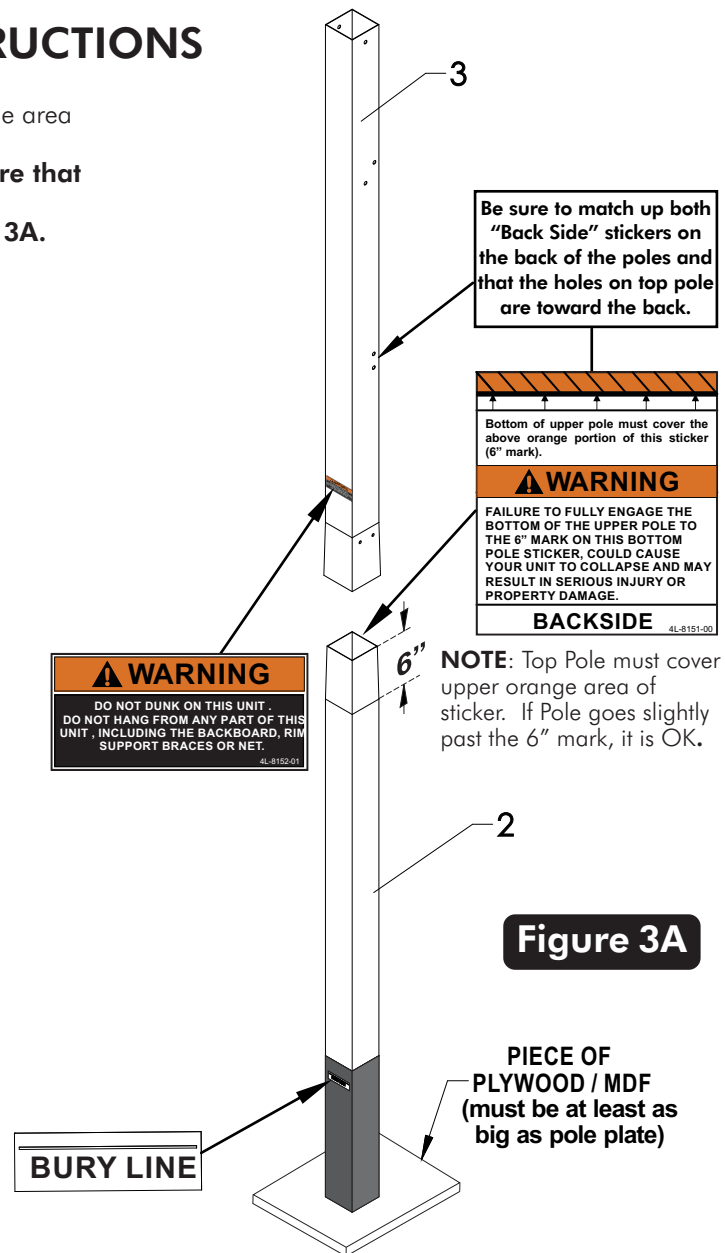

Figure 3A

WARNING
DO NOT DUNK ON THIS UNIT .
DO NOT HANG FROM ANY PART OF THIS UNIT . INCLUDING THE BACKBOARD, RIM SUPPORT BRACES OR NET.

Be sure to match up both "Back Side" stickers on the back of the poles and that the holes on top pole are toward the back.

Bottom of upper pole must cover the above orange portion of this sticker (6" mark).

WARNING
FAILURE TO FULLY ENGAGE THE BOTTOM OF THE UPPER POLE TO THE 6" MARK ON THIS BOTTOM POLE STICKER, COULD CAUSE YOUR UNIT TO COLLAPSE AND MAY RESULT IN SERIOUS INJURY OR PROPERTY DAMAGE.

BACKSIDE 4L-8151-00

NOTE: Top Pole must cover upper orange area of sticker. If Pole goes slightly past the 6" mark, it is OK.

PIECE OF PLYWOOD / MDF (must be at least as big as pole plate)

BURY LINE

WARNING: This pole assembly is heavy. Step 2 will require two adults. Make sure you can control the pole when slamming it together. Have a helper stand on the opposite side of the pole. Attention should be paid to one's feet and toes during entire slamming process.

2. Align the upper pole (#3) with the bottom pole (#2) as shown in Figure 3A and slide them together. While maintaining control of the pole assembly stand poles up **STRAIGHT** on a piece of MDF board or Plywood, **lift poles up by bottom pole** below the 6" mark shown on sticker and slam down the bottom pole as many times as needed on the MDF board or Plywood **until the bottom of the upper pole reaches the 6" mark** (on Sticker) on the bottom pole. Lift the pole 10-12 inches off the ground when slamming the poles together. See Figure 3A & 3B.

IMPORTANT! DO NOT hit poles with hammer or sledge hammer to attach poles together you will damage your pole or pole cap.

NOTE: When slamming poles together make sure to keep the poles **STRAIGHT**. Slamming the poles down crooked will damage the bottom of the pole. Top Pole must cover upper orange area of sticker. If Pole goes slightly past the 6" mark, it is OK.



NOTE: Cordless drill required for screw installation. Do not over tighten screws causing screws to strip.
Once Screw heads touch pole, STOP! Overtightening will cause Pole to Warp and damage system.

NOTE: To install screws, it will be easier if you use a cordless drill with 5/16" socket (instead of Phillips head).

NOTE: Screws #42, used in step 3, are Self Drilling screws and can be installed without drilling pilot holes.
However, it will be easier to install screws if you drill 9/64" pilot holes in bottom pole. WEAR SAFETY GLASSES if drilling holes.

3. Once the Top pole is to the 6" Mark on the Warning Sticker, lay Pole Assembly on its side on two padded saw horses. Insert a (#42) Screw into each 3/16" hole in top Pole, two on each side of the Post Assembly. You will need someone to hold the Pole assembly while inserting screws. Screw must go through both Top and Bottom (Inner) Poles. Make sure to not strip screws once they are all they way through. See **Figure 4**.

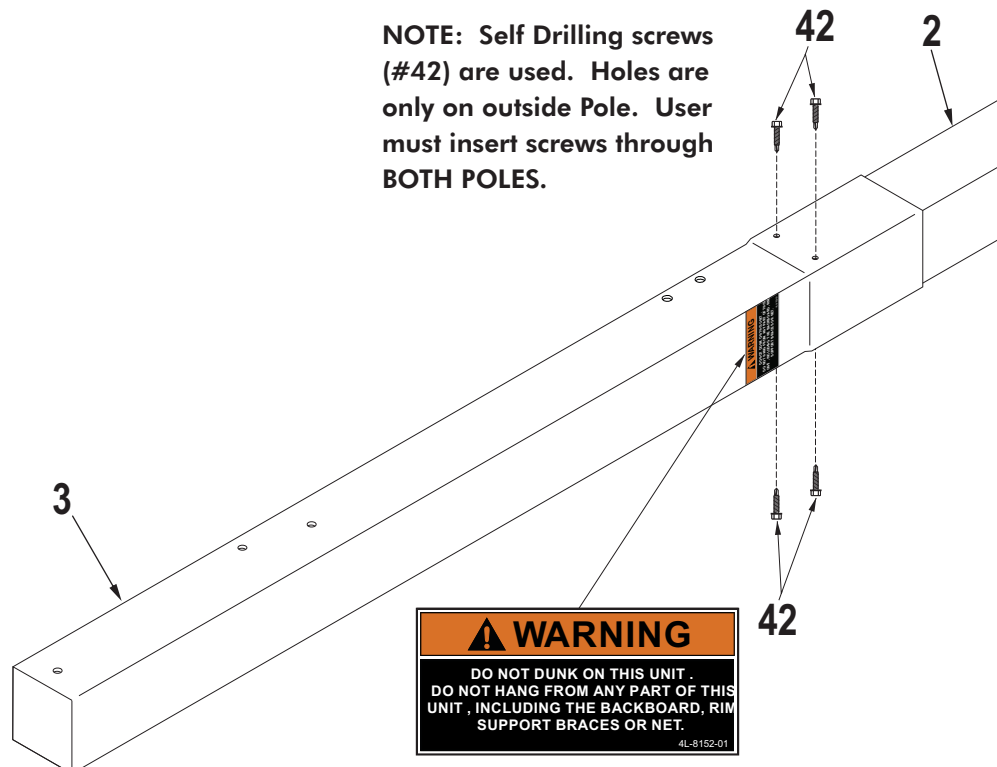

Figure 4

***Tip:** It is always a good idea to purchase two or three extra bags of concrete, just in case you need them. If extra bags are not used you can return them to the store.

- Mix concrete per the instructions on concrete bag. Pour into the hole and stop about 16" from Playing Surface/Court Level or until you can still see the top of the Masonry block you placed earlier. See **Figure 5** and **Detail 1**.
- Set the bottom of the pole on the masonry block in the hole. Make sure the Pole stays on the block as shown in **Figure 5**. The Bury line should be level with the playing surface see **Detail 1**.
- While one person holds the pole in place have two other people finish pouring concrete up to Playing Surface / Court Level. Use a level to make sure Pole is vertical.

CAUTION

THE FOLLOWING STEPS WILL REQUIRE AT LEAST THREE CAPABLE ADULTS.

NOTICE

BE SURE THAT THE HOLES ARE TOWARD THE BACK OF THE POLE AND "BACK SIDE" STICKERS ARE AT THE BACK OF THE POLES/ OPPOSITE THE PLAYING SURFACE BEFORE POURING CONCRETE ON STEPS 4-6.

Figure 5

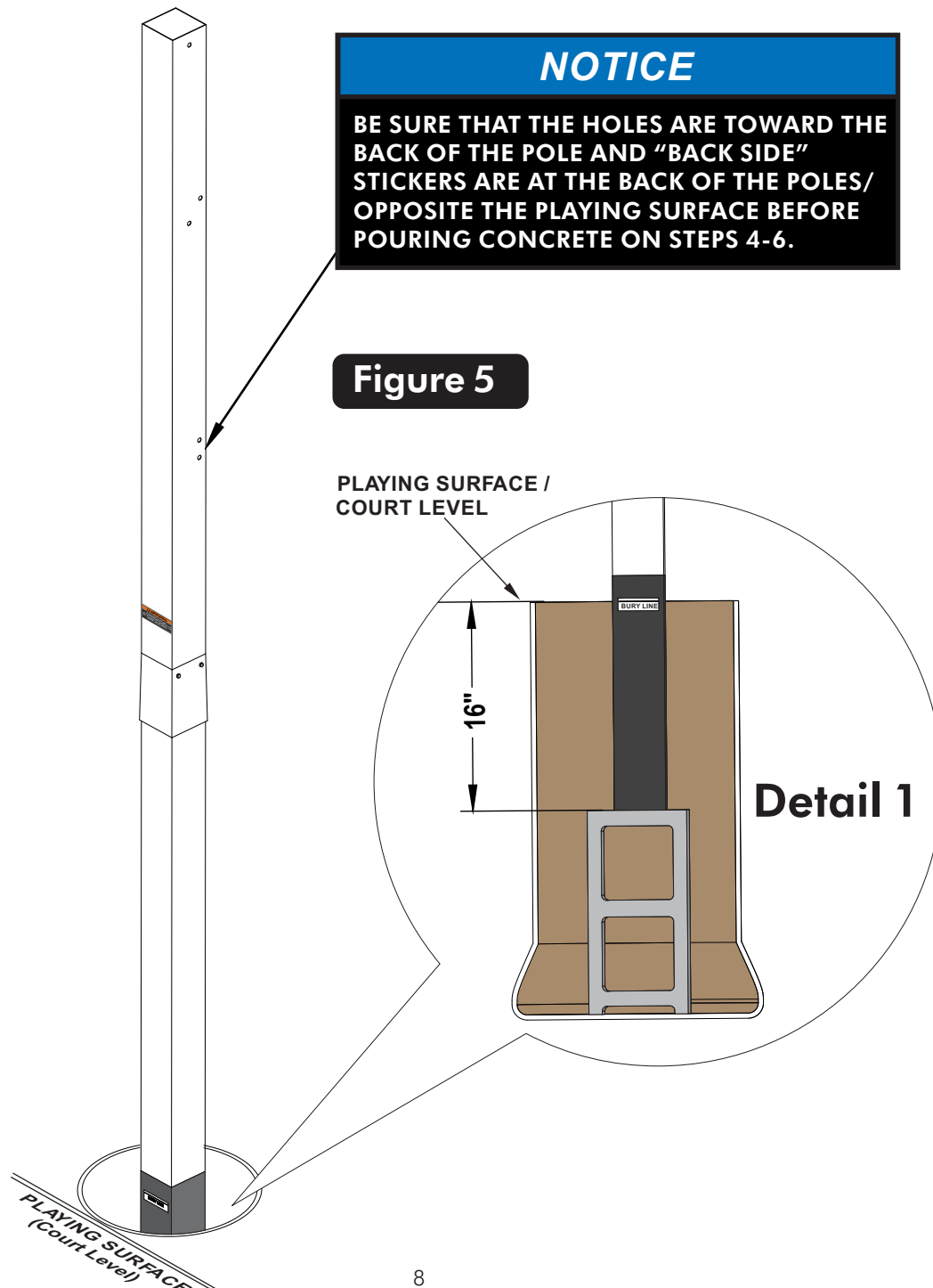

Note: Periodically check pole with level to ensure that pole is vertical.

7. Stabilize the pole by using six 2X4's and placing two 50 lbs. bags of sand on top to keep pole from shifting, periodically check the pole with level to ensure that pole is vertical. See **Figure 6**.

8. Let concrete cure for a **MINIMUM** of 48 hours (2 days).

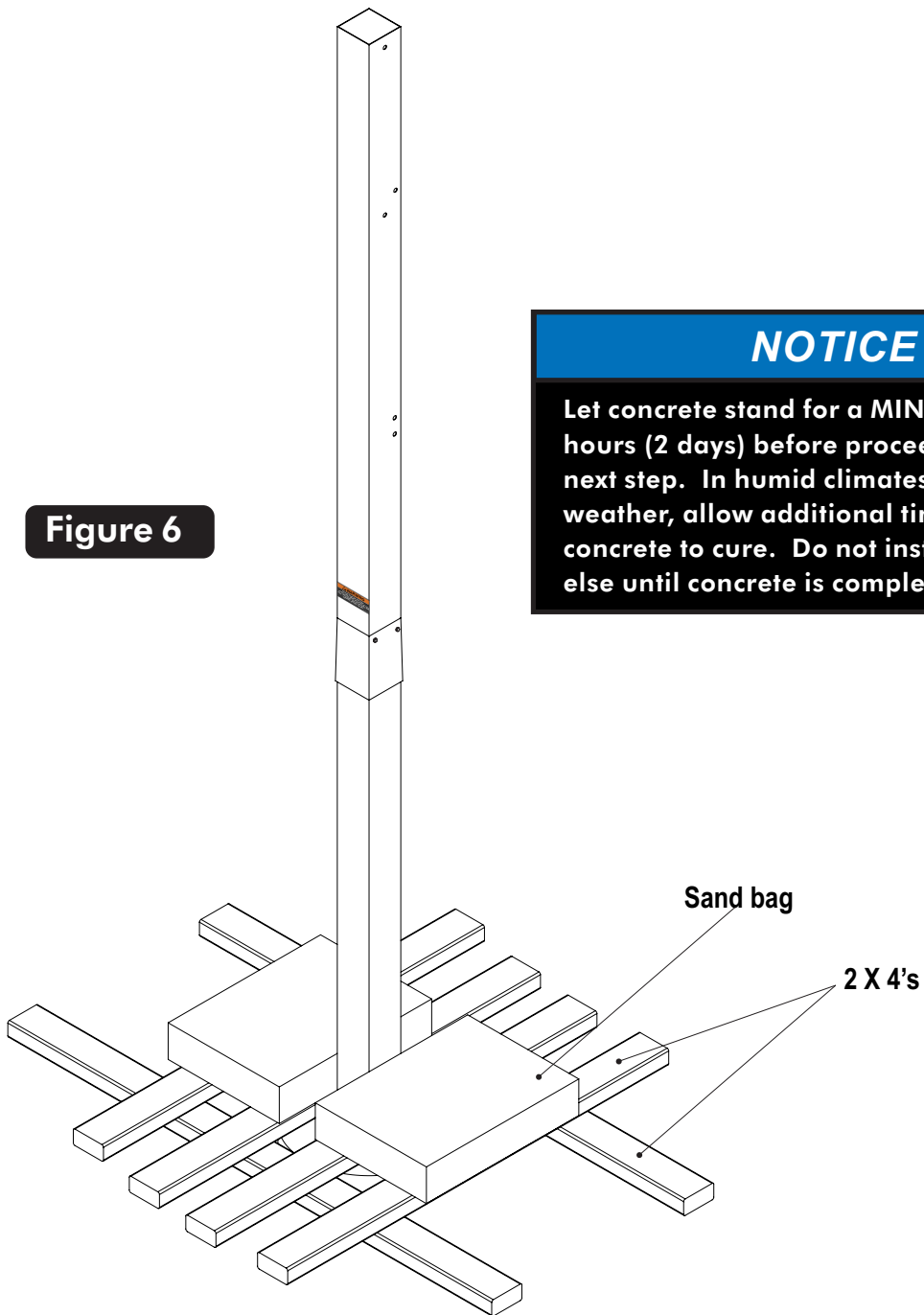

Figure 6

NOTICE

Let concrete stand for a **MINIMUM** of 48 hours (2 days) before proceeding to the next step. In humid climates or wet weather, allow additional time for the concrete to cure. Do not install anything else until concrete is completely cured.

ASSEMBLY INSTRUCTIONS (Day 3)

IMPORTANT! BE SURE CONCRETE HAS BEEN ALLOWED TO CURE FOR AT LEAST 2 DAYS.

9. Attach Post Ears (#30) to holes near the bottom of the Top Post (#3) using two hex bolts (#25) four washers (#18) and two lock nuts (#4). Do not tighten nuts (#4) completely until instructed to do so. See **Figure 7 & Detail 2**.

Figure 7

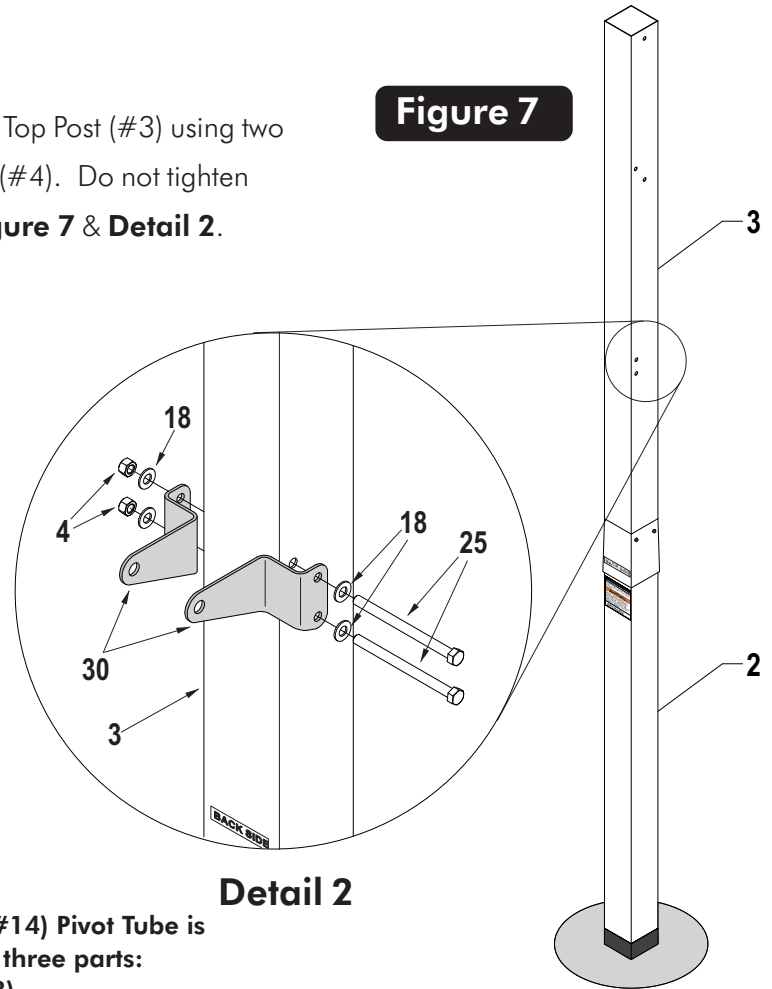

Detail 2

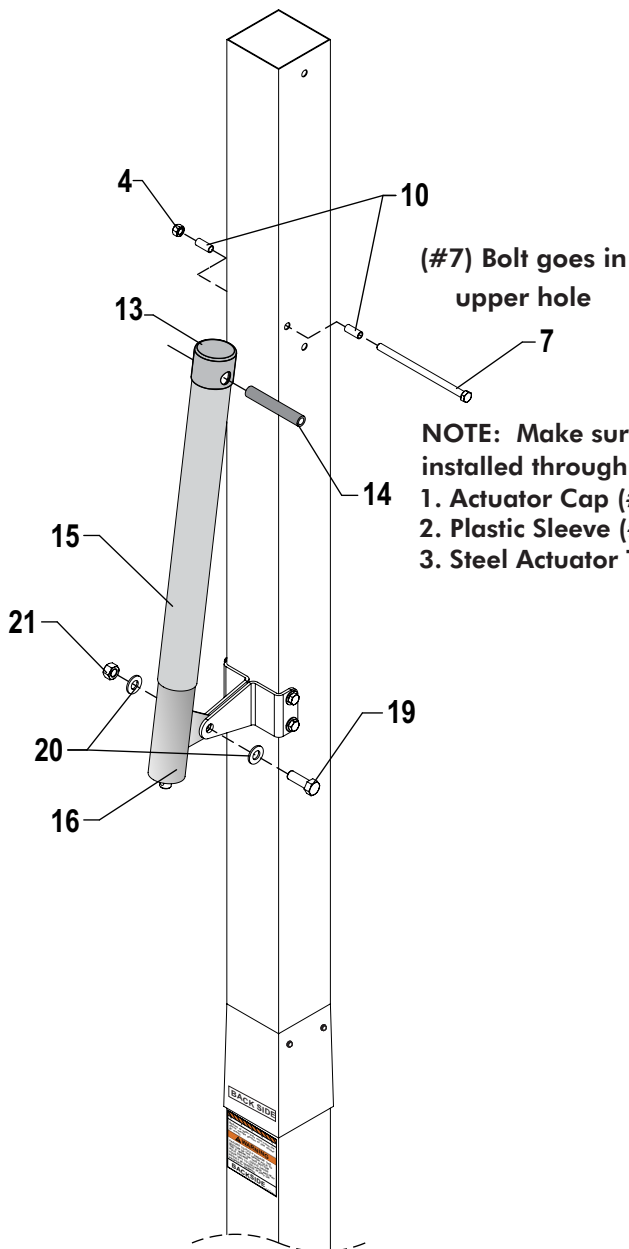

Figure 8

NOTE: Make sure (#14) Pivot Tube is installed through all three parts:

1. Actuator Cap (#13)
2. Plastic Sleeve (#15)
3. Steel Actuator Tube (#16)

10. If not already pre-assembled, slide Plastic Actuator Sleeve (#15) over Steel Actuator (#16) and place Actuator Cap (#13) on top. Align holes in all 3 parts and slide Pivot Tube (#14) through holes in Actuator Cap (#13), Plastic Actuator Sleeve (#15) and Steel Actuator (#16) until equal amounts stick out through both sides of actuator. See **Figure 8**.

Note: If necessary, use a rubber mallet to tap in Pivot Tube (#14)

11. Slide tab on Actuator (#16) between Post Ears #30 and secure using one Bolt (#19), two Washers (#20) and one Lock Nut (#21). Tighten Lock Nut (#21) snug but **DO NOT** over tighten. See **Figure 8**. At this time also **tighten nuts (#4) from Step 9**.
12. Secure two Stop Spacers (#10) to pole, as shown in Figure 8, using one Hex Head Bolt (#7) and one Lock Nut (#4). Tighten Lock Nut (#4) but **DO NOT over tighten**.

IMPORTANT! Nylon washers (#5) adequately space painted parts at all pivot points. Neglecting the use of these washers will result in rusted parts.

NOTE: All board arms are made of rectangular tubing. Tightening hardware too tight may damage tubing and make adjustment of system difficult.

13. Attach lower arms (#11) to Top Pole (#3), as shown in **Figure 9**, using a hex bolt (#22), two flat washers (#18), two plastic washers (#5) and lock nut (#4).

Note: Small amounts of clear tape can be used to adhere Plastic Washers (#5) to Pole. This will make assembly easier.

Note: make sure lettering is right side up. Do NOT tighten bolt (#22) at this time.

14. Secure Actuator (#16) to Lower Arms (#11) using one bolt (#22), two flat washers (#18), two plastic washers (#5) and one lock nut (#4). See **Figure 10** and **Detail 3**. Tighten both bolts (#22) snug but, **do not over tighten. Board Arms must pivot freely.**

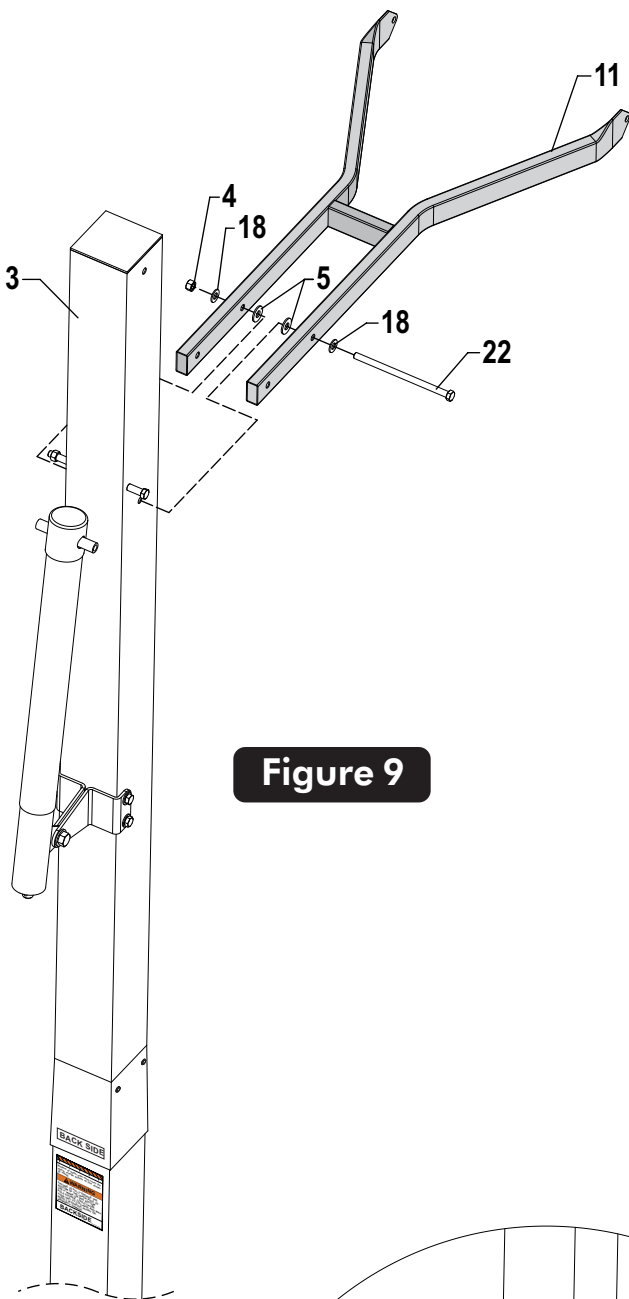
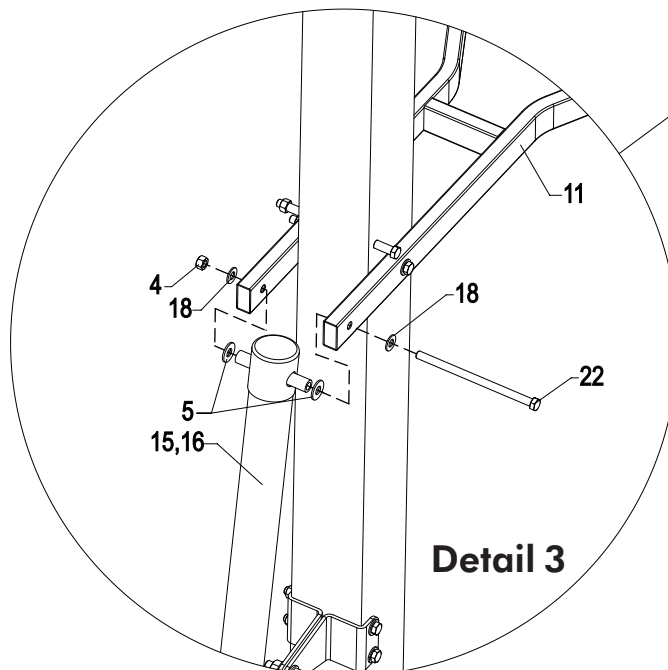

Figure 9



Detail 3

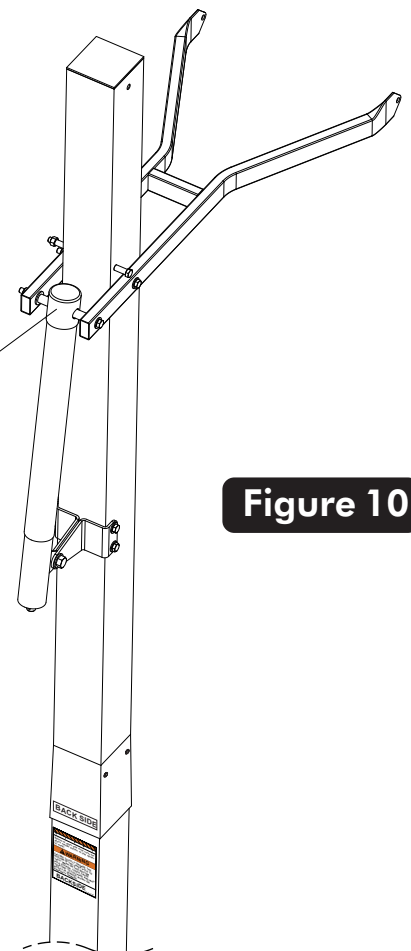

Figure 10

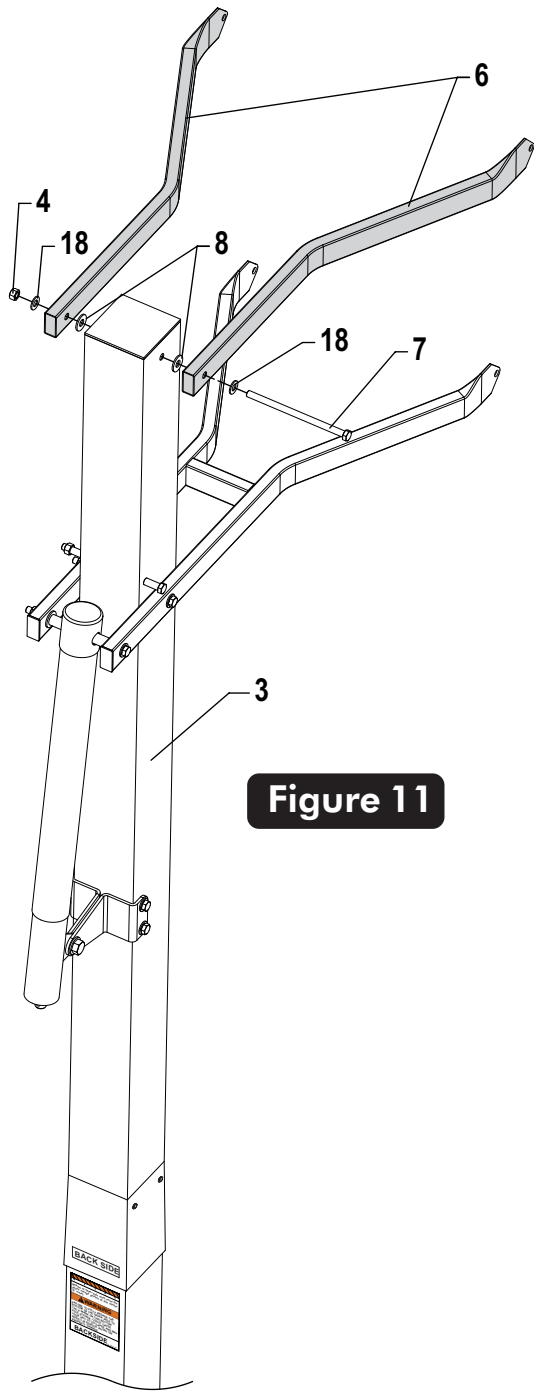

Figure 11

15. Attach of Upper Arms (#6) to Top Pole (#3), as shown in **Figure 11**, using a bolt (#7), two flat washers (#18), two spacers (#8) and one lock nut (#4).

Note: Tighten bolts snug but, do not over tighten. Board Arms must pivot freely

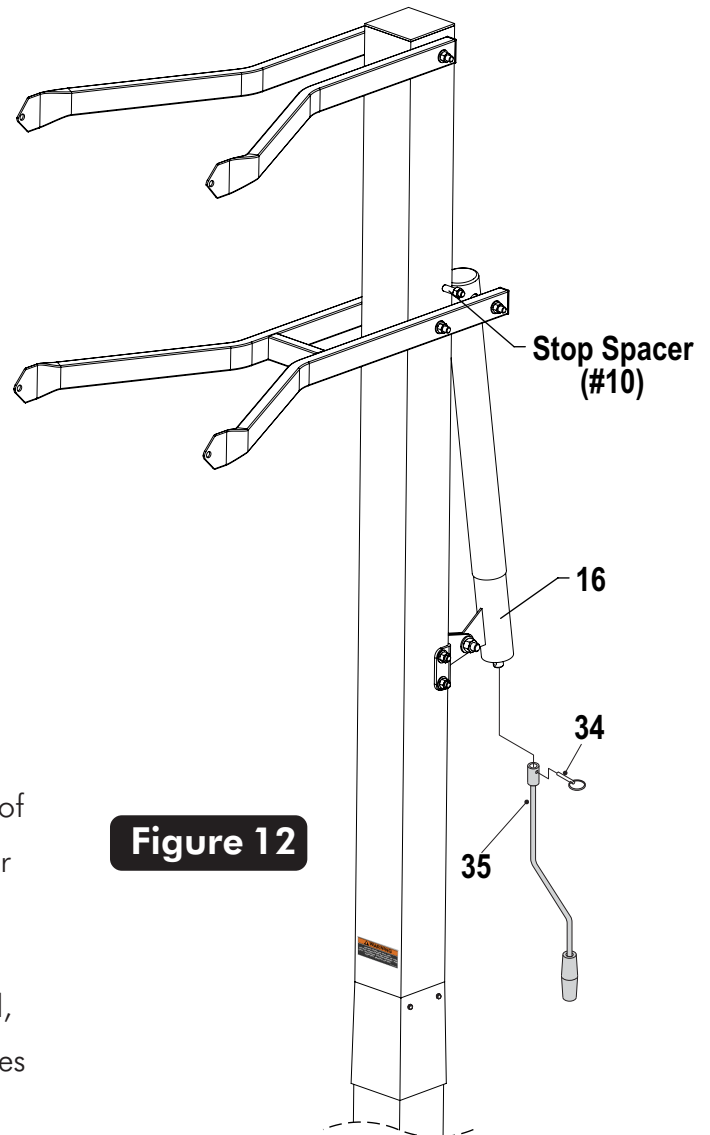

Figure 12

16. Slide Actuator Handle (#35) onto shaft on the bottom of Actuator (#16). Line up hole in shaft with hole in Actuator Handle and insert Pin (#34) to secure. See **Figure 12**.

17. To aid in the assembly of the backboard, lower the backboard, by turning the Actuator Handle, until the lower arm makes contact with Stop Spacer (#10).

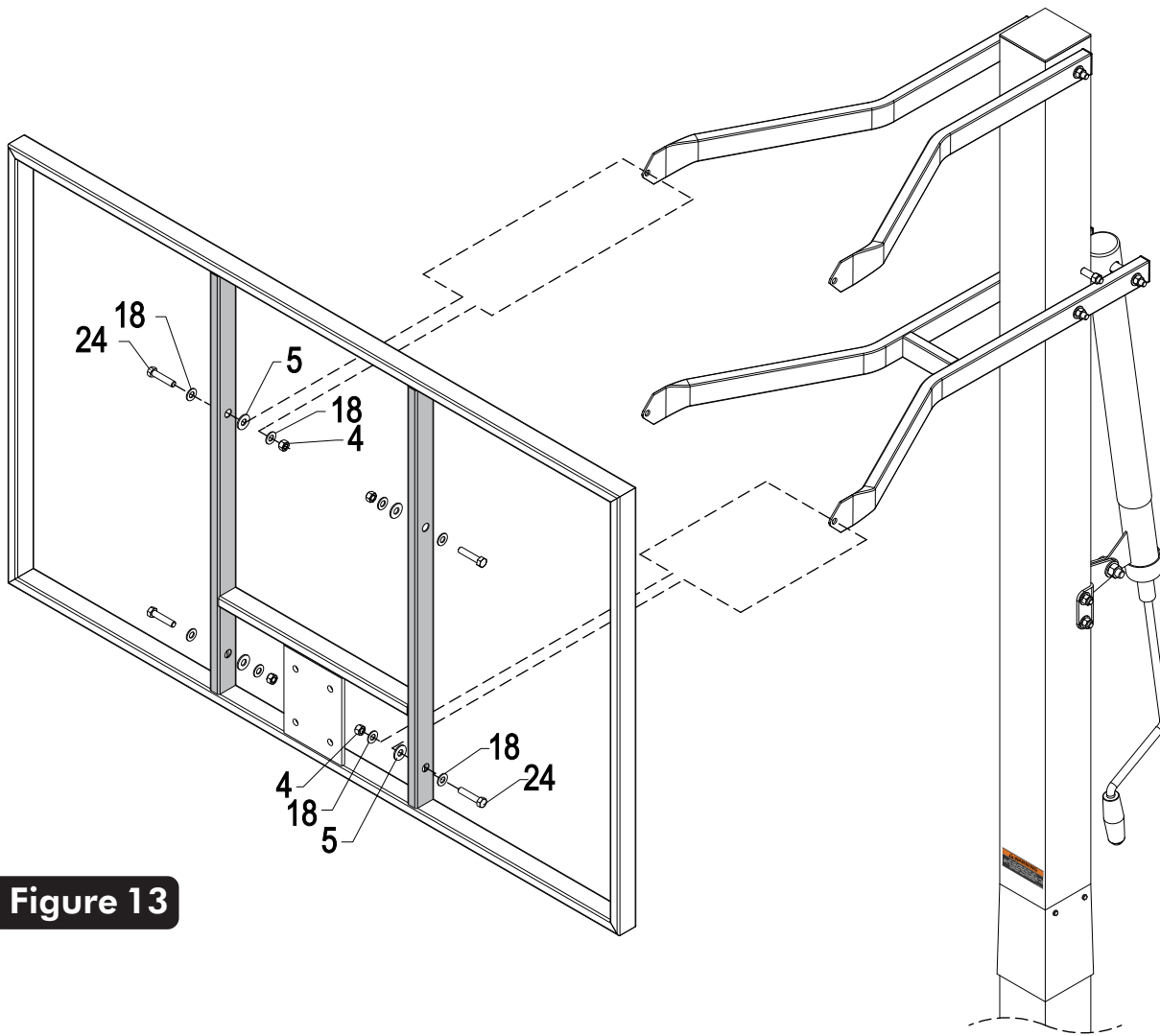

Figure 13

18. With at least two capable people, raise the backboard assembly up and have the third attach Lower Board Arms to lower mounting tubes on backboard using two bolts (#24), two plastic washers (#5), four washers (#18) and two lock nuts (#4). See **Figure 13**.

NOTE: Do NOT over tighten these bolts. This is a pivot point. Snug is tight enough.

19. Attach Upper Board Arms to upper mounting tubes on backboard using two bolts (#24), two plastic washers (#5), four washers (#18) and two lock nuts (#4). See **Figure 13**.

NOTE: Do NOT over tighten these bolts. This is a pivot point. Snug is tight enough.

! WARNING

ATTACHING BACKBOARD TO BOARD ARMS REQUIRES AT LEAST FOUR CAPABLE ADULTS.

! CAUTION

HANDLE BACKBOARD WITH CARE, IT IS A GLASS PRODUCT. ALWAYS WEAR SAFETY GLASSES AND GLOVES WHEN HANDLING GLASS.

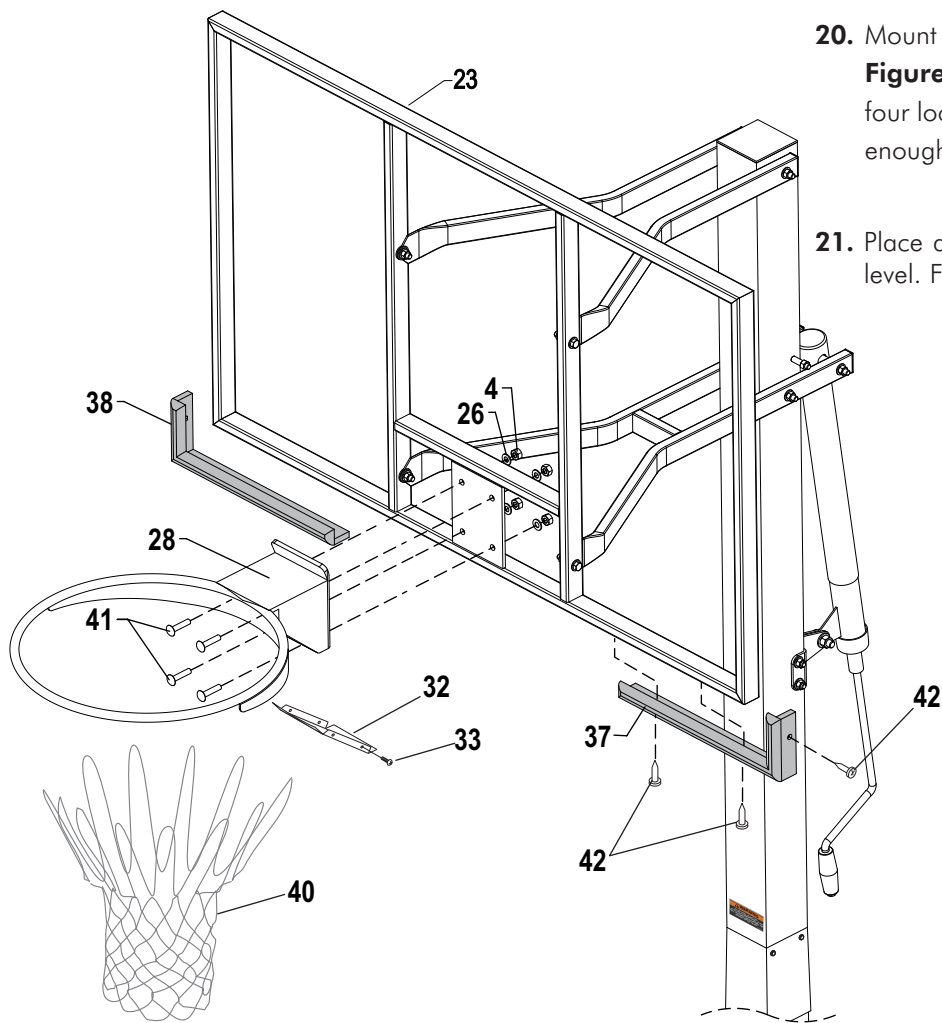

20. Mount Goal Assembly (#28) to Backboard, as shown in **Figure 14**, using four bolts (#41), four washers (#26), and four locknuts (#4). Tighten fasteners, but leave them loose enough to level rim.

21. Place a level across rim assembly and adjust rim until it is level. Finish tightening the four nuts.

Figure 14

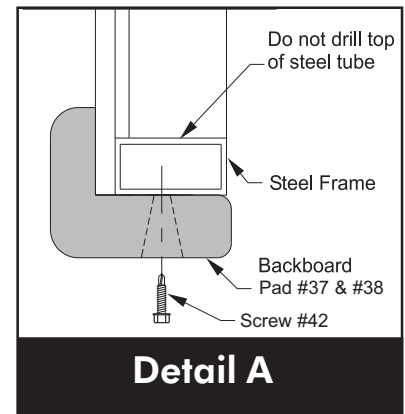

22. Attach Rim Cover Plate (#32) using four screws (#33). See **Figure 14**.

23. Check all nuts and bolts and make sure everything is tightened properly. **DO NOT over tighten** pivot points, snug is tight enough.

24. Use the Backboard Pads (#37) and (#38) as a template and mark the hole locations on the backboard frame. See **Figure 14** and **Detail A**.

Note: Screws (#42), used in step 26, are Self Drilling screws and can be installed without drilling pilot holes. However, it will be easier to install screws if you drill 9/64" pilot holes. **WEAR SAFETY GLASSES** if drilling holes.

25. Drill 9/64" pilot holes into steel backboard frame. See **Detail A**. **Do not drill through both sides of tube.**

Note: Cordless drill recommended for screw installation. **Do not over tighten** screws causing screws to strip.

Note: To install screws, it will be easier if you use a cordless drill with 5/16" socket (instead of Phillips head).

26. Secure Backboard Pads (#37) and (#38), as shown, using screws (#42). Note: Tighten screws tight but, **do not over tighten**.

27. Raise Backboard to 10 FT. regulation playing height. Measure from top of rim straight down to the playing surface.

28. Using tape - mark the **side** of the steel actuator (#16) just under the plastic actuator sleeve (#15) at this 10 ft rim height. See **Figure 15**.

29. Lower backboard all the way down. Do not force actuator once backboard is in it's lowest position. See **Figure 16**.

30. **Do not** remove adhesive backing from height decal (#17) yet. Carefully place height decal on backside of steel actuator (#16) and line up the 10 ft mark on the tape with the 10 ft mark on the height decal. Decal should fit correctly onto the backside of the steel actuator. (If not , simply trim to fit the top of the actuator decal).

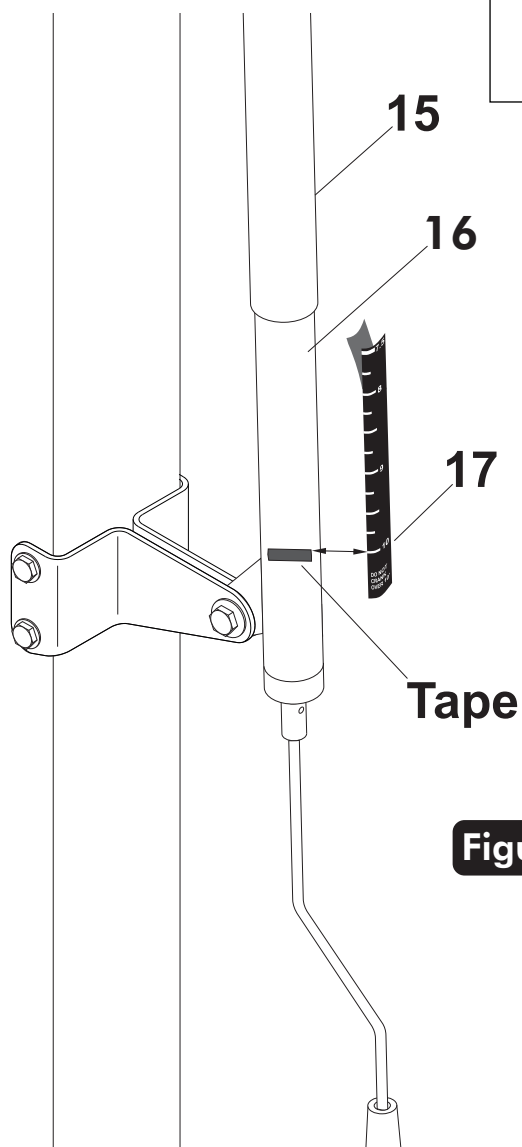
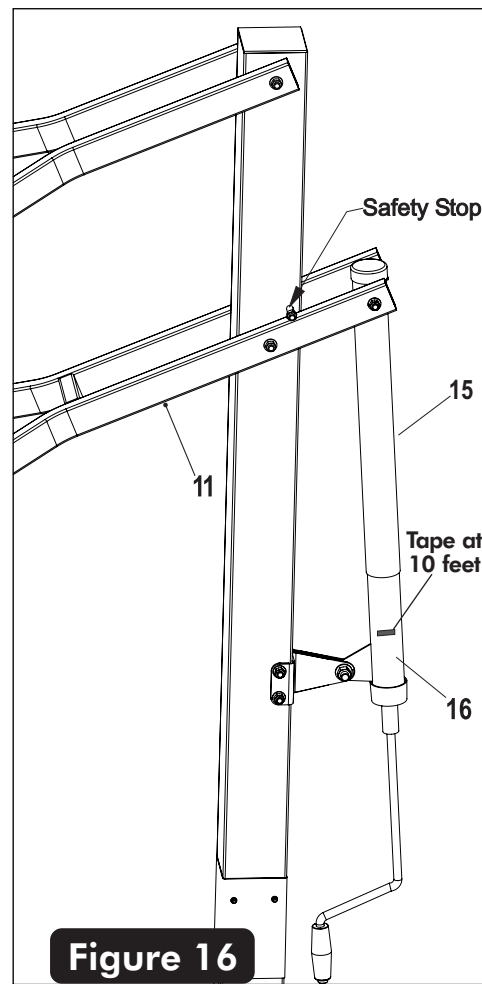
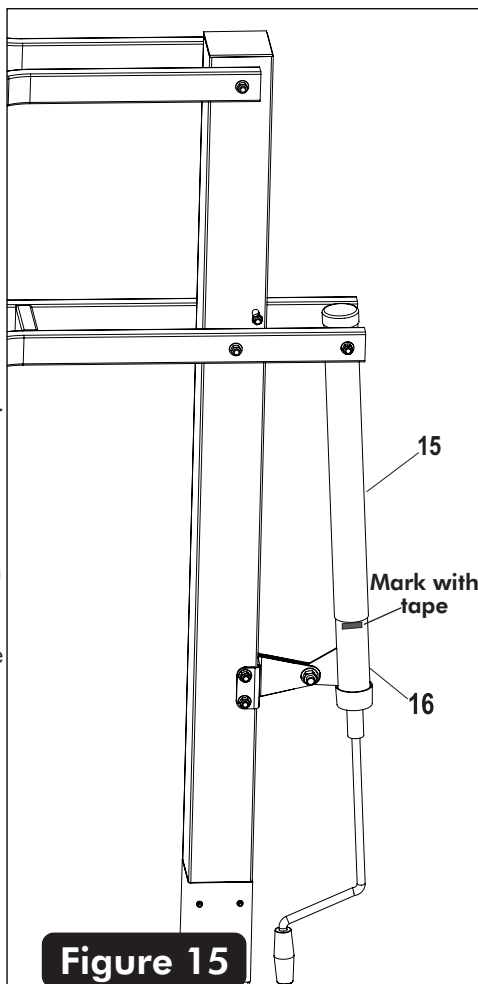

31. Remove the adhesive backing from the Height Decal (#17). Next, carefully align and stick decal to backside of steel actuator (#16) starting at the **10 ft mark first**. Be sure to keep the height decal straight and rub out all air bubbles. See **Figure 17**.

32. Secure Post Pad (#39) to front of pole by wrapping straps around pole and sticking to velcro on opposite side of Pad. Post Pad should cover Post Screws but remain below Warning Label on front of the Pole. See **Figure 18**. Make sure to reposition Pole Pad if Sliding occurs.

NOTE: Do not cover the Warning Label on the front of the pole with the Pole Pad.

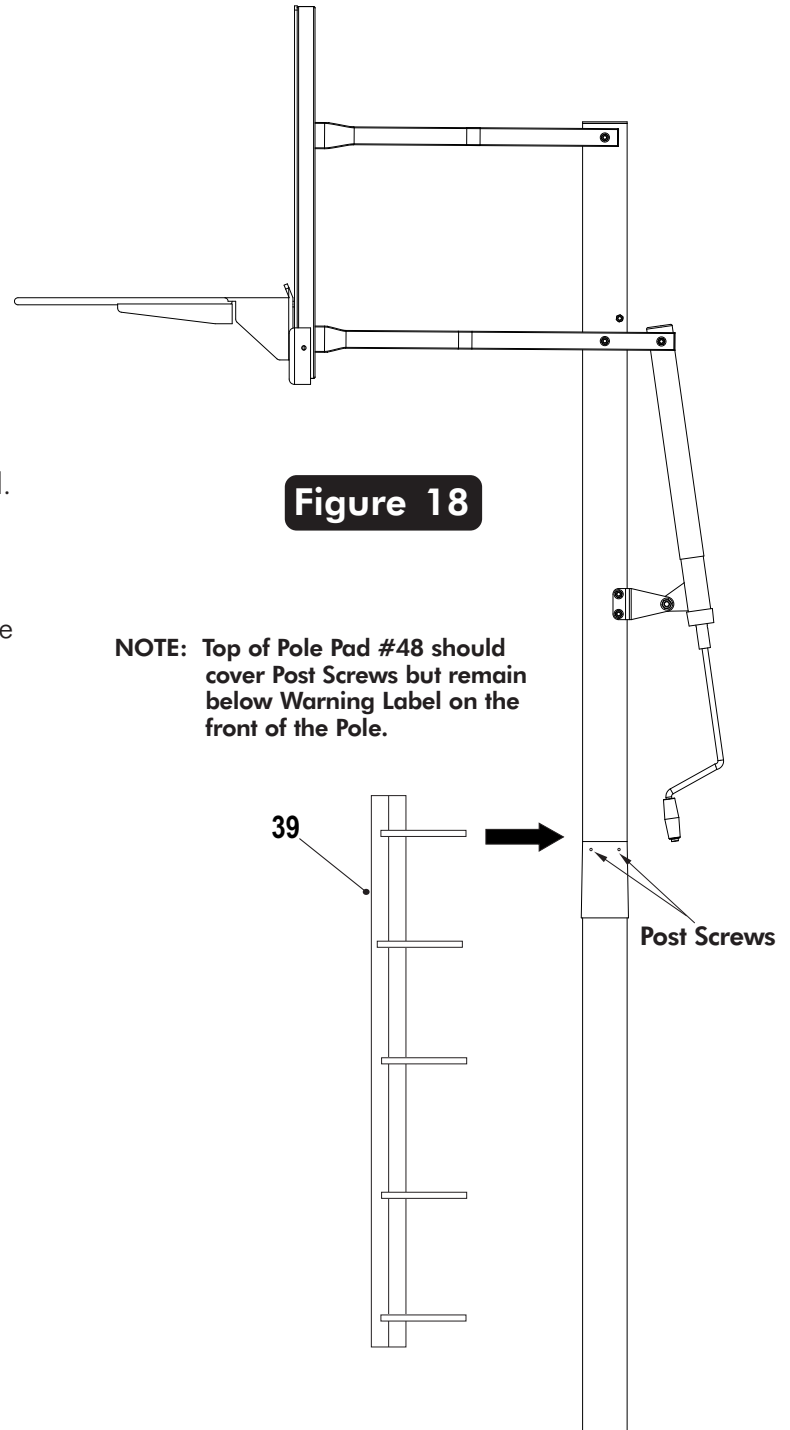

LIMITED 7 YEAR WARRANTY

This consumer warranty extends to the original consumer purchase of any Escalade® Sports Product (hereinafter referred to as the "Product").

WARRANTY COVERAGE: Escalade® Sports warrants to the original Consumer Purchaser that any Product of its manufacture is free from defects in material and workmanship. THIS WARRANTY IS VOID IF THE PRODUCT HAS BEEN DAMAGED BY ACCIDENT, UNREASONABLE USE, NEGLIGENCE, IMPROPER SERVICE, FAILURE TO FOLLOW INSTRUCTIONS PROVIDED WITH THE PRODUCT OR OTHER CAUSES NOT ARISING OUT OF DEFECTS IN MATERIAL OR WORKMANSHIP.

Subject to proper installation and normal Residential use, Escalade® Sports warrants, subject to the limitations below, to the original retail purchaser all structural components of the Silverback® System to be free of defects in material and workmanship for a period of Seven (7) years from the original purchase.

Merchandise must be shipped prepaid with a copy of proof of purchase to Escalade® Sports factory for examination to determine if the basketball system needs to be repaired or replaced. Any labor costs, travel expenses and any other changes involved in the removal, installation or replacement of the defective/repared parts from/to your Silverback® System will be the purchaser's responsibility. Shipping charges for replaced or warranted merchandise sent back to the customer from Escalade® Sports factory must be prepaid by the customer in advance. If not, the replacement shipment will be sent out collect.

Escalade® Sports reserves the right to examine photographs or physical evidence of merchandise claimed to be defective, and to recover said merchandise, prior to authorization of warranty claims. A "Returned Goods Authorization" number may be required, please call for details prior to the return of any photographs or merchandise.

This limited 7 year warranty is expressly in lieu of all warranties, expressed or implied, including warranties of merchantability or fitness for use. Escalade® Sports does not assume or authorize any person or representative to assume for us, any other liability in connection with the sale of our products.

The remedy of repair or replacement stated above is Escalade® Sports exclusive remedy. Escalade® Sports will not be liable for any other damages or expenses which may incur, including but not limited to incidental or consequential damages. Escalade® Sports assumes no other obligations or liability on the part of the purchaser, and Escalade® Sports neither assumes nor authorizes any other person to assume for it any other liability in connection with the goods sold.

This warranty shall not apply in any manner to parts or accessories not manufactured by Escalade® Sports.

NOT COVERED BY THIS WARRANTY

- Merchandise not intended to be in places of public assembly, such as, but not limited to, schools, parks, public or private recreational facilities.
- Any merchandise subjected to Non-residential abuse, negligence, improper installation, vandalism, acts of God, alteration of product, or any other events beyond the control of Escalade® Sports.
- Paint or rusted parts. If rust should appear, remove loose paint, sand lightly, primer and paint with exterior flat matte finish enamel paint.
- HANGING ON RIM WILL VOID THE WARRANTY: Rims are not warranted for any defects other than workmanship. Torn back plates, damaged springs, bent rings, damaged eyebolts, and torn or distorted rim supports result from hanging on the rim and are not warranted.
- Shipping charges both ways. Note: Any merchandise shipped to Escalade® Sports collect will be refused.
- Dealer service charges, labor charges and travel expenses associated with replacement of repair of warranty item.

WARRANTY DISCLAIMERS: ANY IMPLIED WARRANTIES ARISING OUT OF THIS SALE, INCLUDING BUT NOT LIMITED TO THE IMPLIED WARRANTIES OF MERCHANTABILITY AND FITNESS FOR A PARTICULAR PURPOSE, ARE LIMITED IN DURATION. ESCALADE® SPORTS SHALL NOT BE LIABLE FOR LOSS OF USE OF THE PRODUCT OR OTHER CONSEQUENTIAL OR INCIDENTAL COSTS. EXPENSES OR DAMAGES INCURRED BY THE CONSUMER OF ANY OTHER USE.

Some states do not allow the exclusion or limitation of implied warranties or consequential or incidental damages, so the above limitations or exclusions may not apply to you.

LEGAL REMEDIES: This warranty gives you specific legal rights, and you may also have other rights which may vary from state to state.

WARRANTY GUIDELINES IS REQUIRED FOR ALL WARRANTY CLAIMS

1. Proof of Purchase (original retail purchaser) is required for all warranty claims.
 2. Call or write Escalade® Sports to receive a Return Authorization # and determine specific needs.
- Phone: 1-888-USA-GOAL / Warranty Dept.
Or Write Escalade® Sports at: Escalade® Sports - P.O. Box 889, Evansville, IN 47706 - Attn: Warranty Dept.
Or E-mail us at: basketball@escaladesports.com

CARE AND MAINTENANCE

BACKBOARD CARE AND MAINTENANCE

Items needed to clean backboard:

- 100% cotton soft cloth, (only)
- Glass cleaner

Clean backboard using only a **100% Cotton** soft cloth and glass cleaner Clean glass as you would clean household windows. Strong cleansers will damage backboard and void warranty.

MAINTENANCE

To ensure ease of operation, lubricate all pivot points at least every 6 months or as needed with a good lubricant such as WD-40.

RUST

Inspect your pole periodically, if rust should appear, remove loose paint, sand lightly, primer and paint with exterior flat matte finish enamel paint.

NOTICE

- **Do not crank the goal over 10'. Damage to the actuator could occur.**
- **Do not allow children to adjust system.**

B5400 REPLACEMENT PARTS LIST

Key#	Part #	Description	Qty.
1	3M-6850-00	4" Square Tube Plug (pre-installed)	1
2	8S-6899-02	Bottom Post	1
3	8S-6863-00	Top Post	1
4	901-28	3/8-16 Lock Nut	14
5	3M-6883-00	1-1/4" OD Plastic Washer	8
6	8S-6865-00	Upper Board Arm	2
7	1B-6484-10	3/8-16 X 7" Hex Bolt - Grade 5	2
8	3M-6269-00	1/4" Spacer	2
9	3M-6898-00	40mm X 20mm Plug (Pre-Installed)	4
10	8S-6657-00	Stop Spacer	2
11	1A-7030-01	Lower Board Arm	1
12	Not Used		
13	3M-6467-00	Actuator Cap (Pre-Installed)	1
14	8S-6658-00	Pivot Tube	1
15	3M-6542-00	Actuator Sleeve (Pre-Installed)	1
16	4A-6605-00	Actuator	1
17	4L-8110-00	Height Decal	1
18	701-50	3/8 STD Washer	18
19	1B-6486-10	1/2-13 X 1-1/2" Hex Bolt	1
20	2B-6093-00	1/2 Flat Washer	2
21	2B-6095-00	1/2-13 Locknut	1
22	1B-6957-00	3/8-16 X 6.5" Hex Bolt-Grade 5	2
23	6A-7426-01	Backboard Assembly- 54x33" Glass	1
24	1B-6955-00	3/8-16 X 1.75" Hex Bolt	4

Key#	Part #	Description	Qty.
25	1B-6485-10	3/8-16 X 5" Hex Bolt	2
26	2B-6114-00	3/8 Flat Washer	4
27	Not Used		
28	6A-6374-00	Goal Assembly	1
29	Not Used		
30	2S-6795-01	Post Ear	2
31	Not Used		
32	2S-6427-00	Rim Cover Plate	1
33	1B-6788-00	#8 x 1/2 Thread Forming Scr.	4
34	7B-6255-00	Pull Pin	1
35	4A-6606-00	Actuator Handle	1
36	2L-7196-06	This Manual	1
37	3M-6899-01	48" Board Pad Right	1
38	3M-6900-01	48" Board Pad Left	1
39	3M-8901-01	Post Pad	1
40	3F-6010-00	Net	1
41	1B-6782-00	3/8-16 x 1 3/4" Carriage Bolt	4
42	1B-6821-00	Self Tapping Screw-#10 x 1"	10

