

ASSEMBLY INSTRUCTION

ROUND TABLE

A Table Top

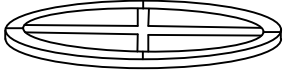

1pc

B Base

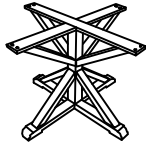

1pc

C Bolt
Ø5/16"x1-1/2"



8pcs

D Flat Washer
Ø5/16"x22mm



8pcs

E Lock Washer
Ø5/16"x13mm



8pcs

F Allen Key
M5

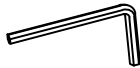

1pc

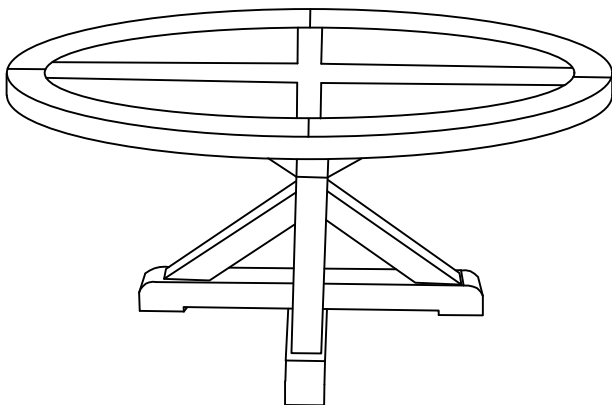

This page lists all the contents included in the box. Please take the time to identify the hardware as well as the individual components to this product. As you unpack and prepare for assembly, place the contents on a carpeted or padded area to protect them from damage.

- 1 Attach Base (B) to Table Top (A) using Bolt (C), Flat Washer (D), Lock Washer (E) by Allen Key (F) as below shown.

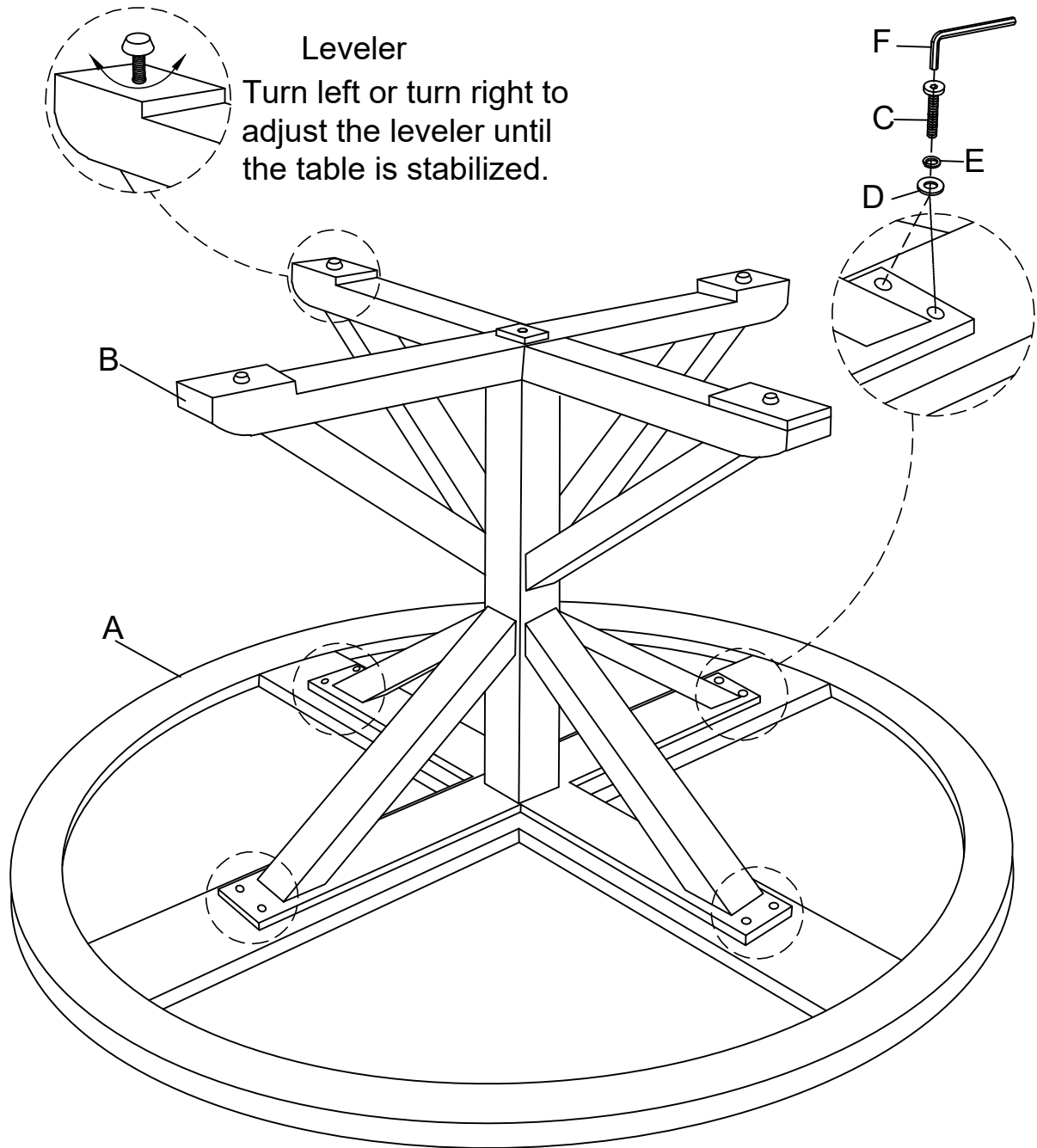

Cleaning & Care

Treat surface with care. Surface is resistant to scratches but is not scratch resistant. Clean surfaces with a dry or damp soft cloth. Do not use abrasive cleaners. Hardware may loosen over time. Periodically check that all connections are tight.