





ASSEMBLY INSTRUCTIONS

25270/25470 & 25271/25471 HFR - Upholstered Queen / King Bed

NO.	HARDWARE LIST		Q'ty
A		Double Thread m8 x 100	8
B		Half Moon Washer	8
C		Nut m8	8
D		Wrench	1
E		Screw Ratan 8 x 1 1/4	8

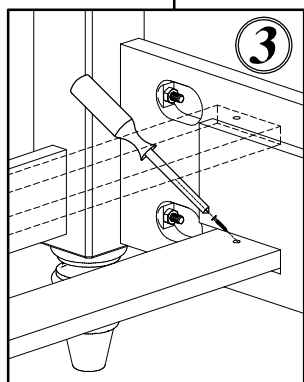
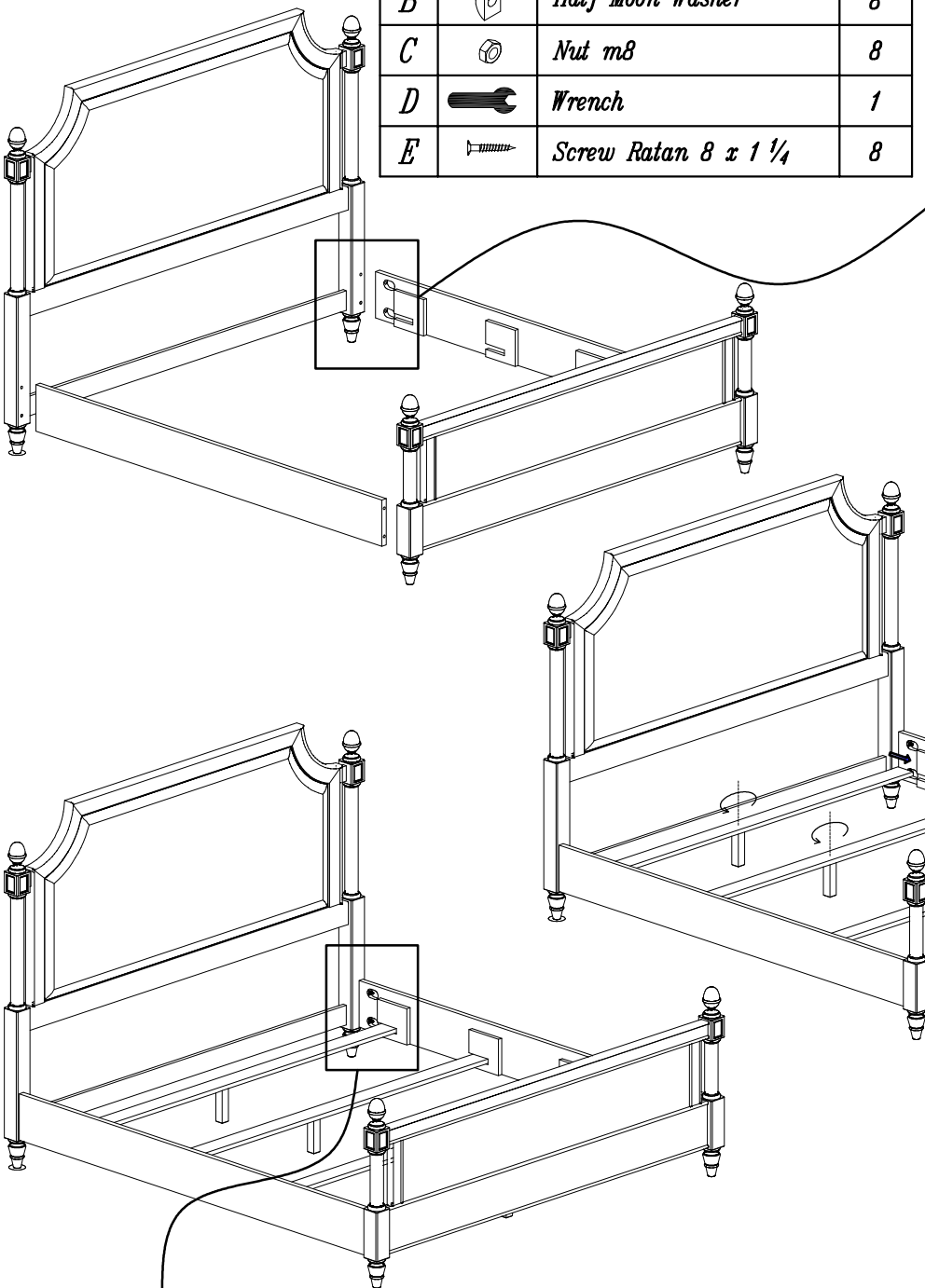
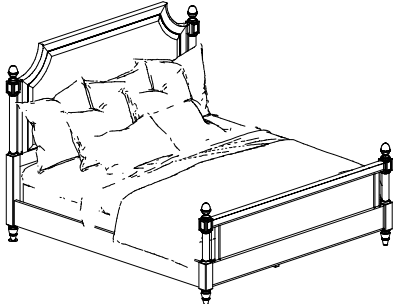
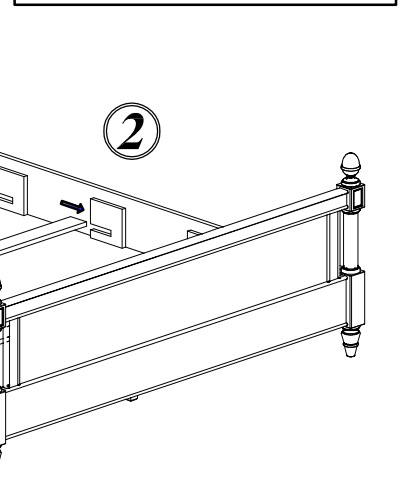
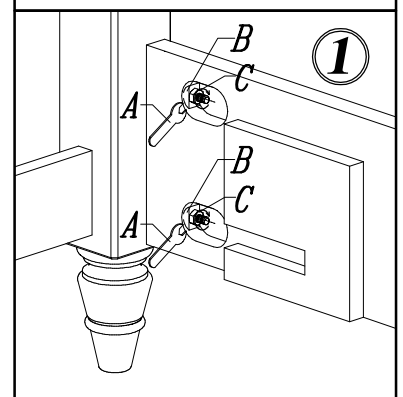
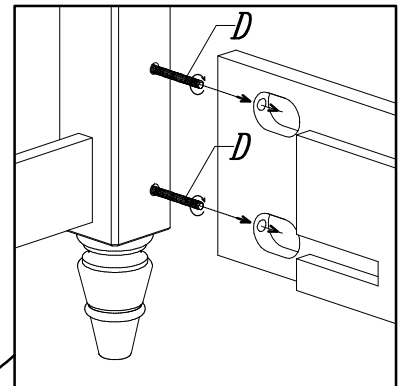

* SCREW DRIVER
NOT INCLUDED

1. ASSEMBLY BED RAILS TO THE HEADBOARD AND FOOTBOARD WITH THREADED ROD (A), HALF MOON WASHER (B), AND NUT (C), TIGHTEN USING WRENCH (D)
2. ATTACH THE FEET TO BED SLATS USING LONG SEGMENTS FOR HIGHER POSITION, SHORT SEGMENT FOR THE LOWER POSITION
3. PLACE THE BED SLATS IN THE POSITION THE FEET ARE ADJUSTED FOR, AND ATTACH WITH SCREW (E)

MADE IN INDONESIA