

BLACK DIAMOND[®]

Project Name: _____

Location: _____

Item #: _____

Qty: _____

Black Diamond Chest Freezer, Single Solid Door, 8.1 Cu. Ft., in White

BDCF-9R



Experience superior frozen storage with the Black Diamond Chest Freezer, designed for commercial use in restaurants, cafes, and catering businesses. Constructed with a solid steel door and an embossed aluminum interior, this freezer offers durability and functionality. With an 8.1 cubic feet capacity, it is perfect for storing bulk food. The temperature range of -4° to 3.2°F ensures optimal preservation of frozen goods. Features a mechanical control system and eco-friendly R600a refrigerant for efficient performance. Easy to clean with a manual defrost system and convenient drain plug.

FEATURES AND CONSTRUCTION

- Offers a generous 8.1 Cu. Ft. capacity for ample frozen storage
- Features a 1/8 horsepower side-mounted compressor for efficient cooling
- Constructed with a white powder-coated steel exterior and embossed aluminum interior
- Maintains a temperature range of -4° to 3.2°F for optimal food preservation
- Utilizes eco-friendly R600a refrigerant for efficient cooling performance
- Operates on 115V with a NEMA-5-15P plug for convenient power access
- Includes a wire coated basket for organized storage
- Built-in casters provide easy mobility for cleaning and repositioning
- Hinged lid opens 90° for easy access to stored items
- Mechanical controls offer user-friendly temperature adjustments

ELECTRIC

115V / Hz / 1Ph

Cord Length (Inches): 70"

Plug Type: NEMA 5-15P

Cord set included

NEMA 5-15P



3RD PARTY APPROVALS



WARRANTY (USA / CANADA)

One (1) Year Limited Warranty on Parts and Labor, One (1) Year Warranty on Compressor and Evaporator

Contact us for details at 1.877.368.2797



STORAGE CAPACITY

- Cubic Feet: 8.1 Cu. Ft.

TEMPERATURE

- Holding Temperature (Fahrenheit): -12 - 6.8

These models are designed to operate in an environment where temperature and humidity do not exceed 75°F (24°C) and 55% relative humidity



Black Diamond Chest Freezer, Single Solid Door, 8.1 Cu. Ft.

BDCF-9R

FRONT

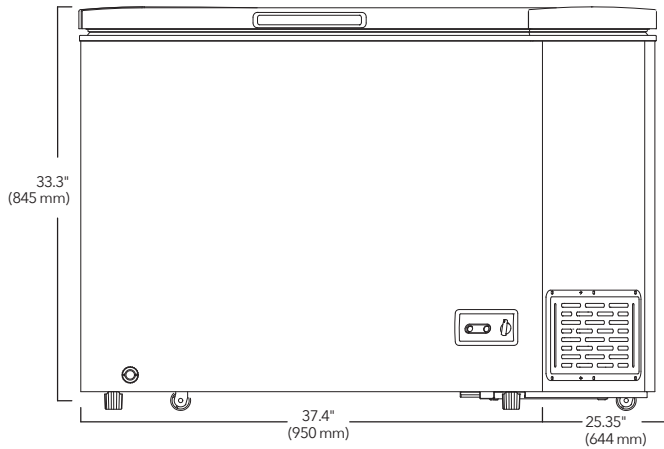

SIDE

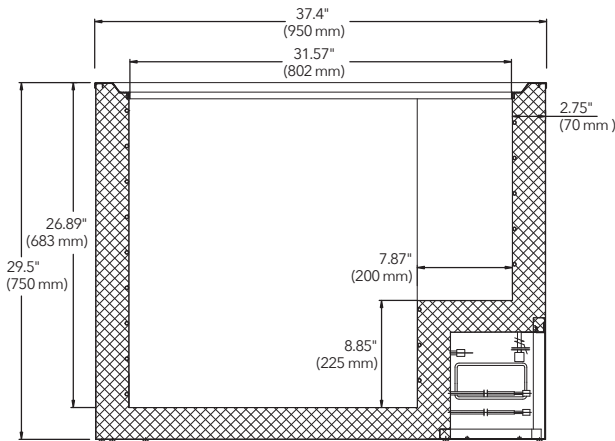
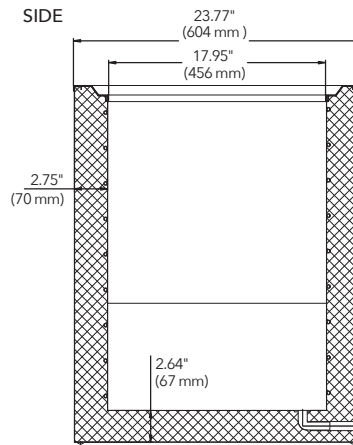

OPEN

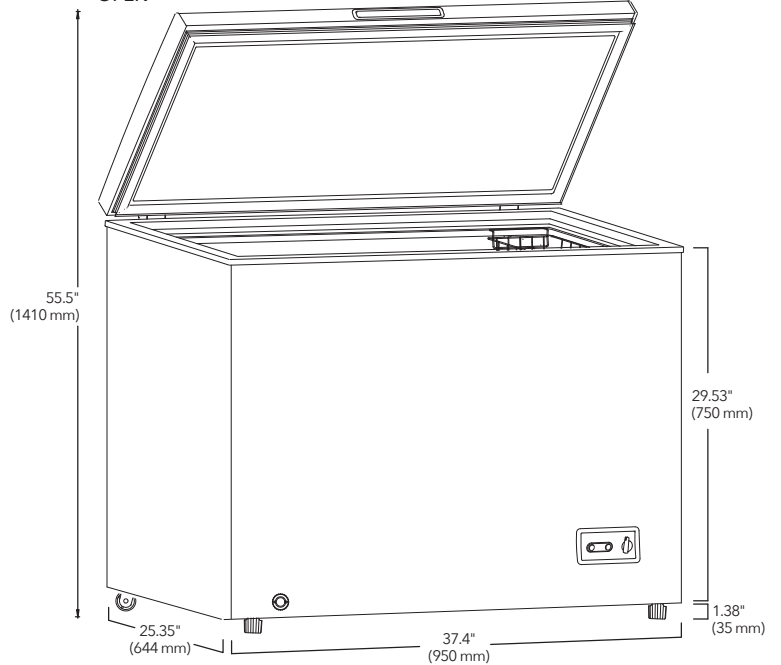

Chest

Doors	Baskets Included	Casters	Refrigerant	Amps	HP	Wattage	Assembled Dimensions (in)	Item Weight (lbs)	Shipping Weight (lbs)
1	1	2	R600a 1.94 oz	1.2A	1/8	150W	25.35" x 37.40" x 33.30"	81.6	92.6

Due to periodic changes in designs, methods, procedures, policies and regulations, the specifications contained in this document are subject to change without notice. While we exercise good faith efforts to provide information that is accurate, we are not responsible for errors or omissions in information provided or conclusions reached as a result of using the specifications. By using the information provided, the user assumes all risks in connection with such use.