

DION SIDE CHAIR ASSEMBLY INSTRUCTIONS

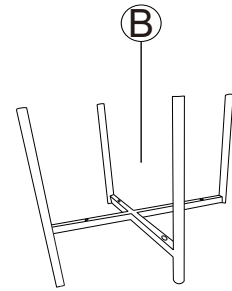

PARTS PACKING CONFIGURATIONS

- A. SEAT 2 PCS
- B. LEG BASE 2 PCS

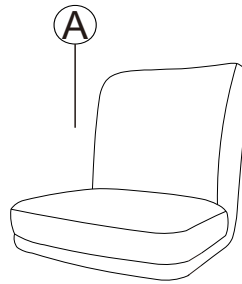

HARDWARE KIT PACKED IN BOX(for 2 chairs)

| NO. | DESCRIPTION | IMAGE | QTY |
|-----|--------------------|-------|-------|
| 1 | FLAT WASHER(M6) | | 8 PCS |
| 2 | ALLEN BOLT(6x35mm) | | 8 PCS |
| 3 | ALLEN KEY(S4) | | 2 PCS |
| 4 | LOCK WASHER(M6) | | 8 PCS |

FULLY ASSEMBLED

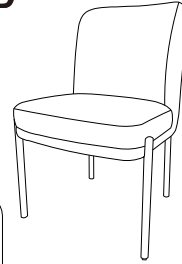

STEP 1:

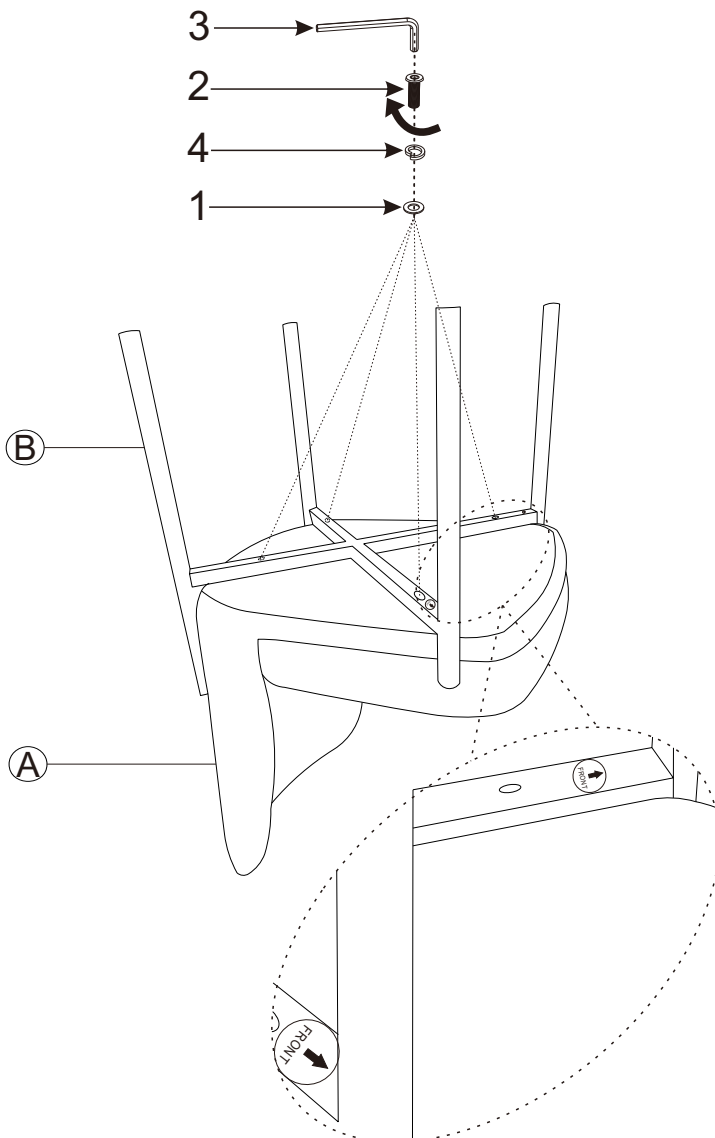

STEP 2:

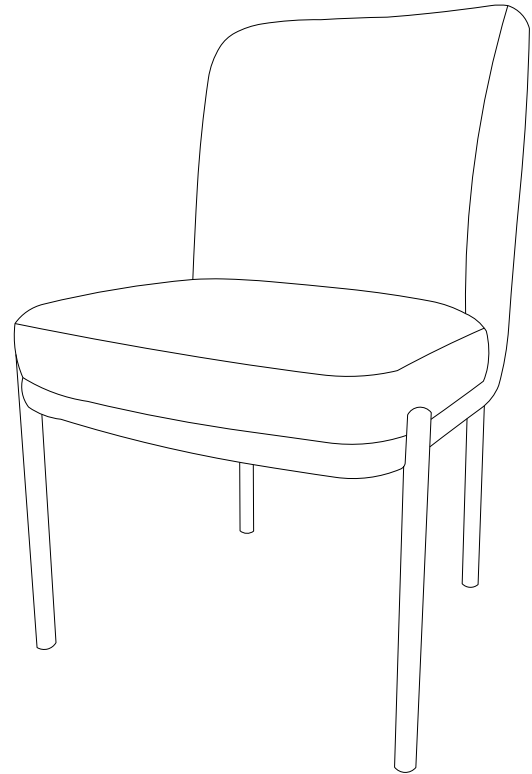

ASSEMBLY COMPLETE

DION SIDE CHAIR ASSEMBLY INSTRUCTIONS



IDENTIFY AND CORRECT WOBBLY SEATING PRODUCTS:

Our seating products are tested on a leveling table prior to packaging. If after unpacking and/or assembly your chairs wobble, follow these steps to eliminate it:

1. If your chair is fitted with leveling feet, adjust them to eliminate the wobble. Please contact us for replacement levelers if yours are missing or damaged.
2. Verify floor protectors on the underside of the chair have not become loose or damaged during transit or assembly. Please contact us if you need replacement floor protectors.
3. Although they appear flat, all floors are uneven. Verify the floor is not causing the wobble by testing the chair in other positions. If you have multiple pieces of the same chair, some that wobble and some that don't, try reversing their positions. This will isolate whether the chair or the floor is causing the wobble.

The following steps apply to ready-to-assemble chairs only:

4. Check assembly fittings. Turn the chair upside down. Apply light to medium cross pressure to each leg, stretcher or other component to test whether it is installed tightly. Use tools indicated in the assembly instructions to tighten fittings as necessary.
5. Ready-to-assemble furniture is designed with small tolerances to facilitate assembly. Occasionally these tolerances can create a wobble, which can be eliminated by reseating the assembly hardware as follows:
 - a. Loosen all fittings a few turns until they are hand tight. Fittings need to be loose enough to be reseated but tight enough to retain their position while they are being re-tightened.
 - b. Place the chair upright on a level surface
 - c. Apply downward pressure on the seat, especially over and around legs that may appear to be longer than the others. Depending on the tightness of the bolts it may require significant pressure or multiple attempts to seat the bolts correctly.
 - d. Once the wobble is corrected, carefully reposition the chair so that assembly fittings are accessible. Being careful not to unseat fittings from their new positions, re-tighten the bolts with tools indicated in the assembly instructions.