

2019 NEW PRODUCT GUIDE





Style, Performance, Service. That's the Fypon® advantage.

FYPON STYLE

Fypon is the recognized leader in polyurethane product design, innovation and molding technology. We offer a wide selection of architecturally correct styles and designs of moulding and trim. Fypon products are designed to capture the texture, patterns and deep shadow lines of classic building materials, adding a distinctive look and personality to any home.

FYPON PERFORMANCE

Manufactured by experts in polyurethane molding technology, each Fypon product is engineered for consistent quality and long-lasting performance.

Fypon polyurethane products are low maintenance and easy to install, with no special tools or extra labor required. They are insect- and moisture-resistant, and won't warp, crack, split or rot.

FYPON SERVICE

Building professionals trust Fypon to deliver outstanding customer service and support.

We provide:

- Drawings and marketing support for blueprints and model homes.
- An industry-first quote package program with quantity pricing tool.
- Support from Fypon experts and answers to common installation questions.
- Custom quotes available for historical replications, or unique profiles to fit your home or commercial application.

For more information, contact CPS@fypon.com.



ELEVATE 2019

Humble Roots | CONFIDENT FOCUS | TIMELESS TWIST

Celebrate style with our new products.

As homeowners focus on bringing their own personal style to life, Fypon is elevating its product portfolio. We've researched the latest home design trends to offer you products that complement the newest home styles.

The Humble Roots trend is grounded in casual living and is brought to life in homes that embrace architectural authenticity. These homes often feature simple, clean design details that incorporate natural textures, dimensional patterns and a softened industrial vibe.

The Confident Focus trend is tied to visually inspired spaces with striking contrasts that have an undercurrent of excitement while still maintaining a sense of calm. Home styles that coordinate with this trend often feature vertical windows, pops of color, geometric styling and mixed materials, inside and out.

The Timeless Twist trend is centered on the reinvention of classics mixed with 21st century living. These homes often have tailored design elements that add character and feature classic patterns and deep, dramatic color palettes to bring an understated sophistication to the home.

Humble Roots

RELAXED | NATURAL | SIMPLE



Unplugged Lifestyles

Love of Local

Informal Surroundings



Casual and comfortable
with a clean edge.

CONFIDENT FOCUS

BOLD | INDIVIDUAL | EVOLVING



TIMELESS TWIST

CHARMING | YOUTHFUL | TAILORED



Modern design with a soft,
livable touch.

Confident Creativity

Visually Inspired

Touching Senses

A fresh, playful twist on traditional.

Heritage Values

New Traditions

21st Century Style

2019 NEW PRODUCTS



DISTINCTION CROSSHEAD | PAGE 10, 28

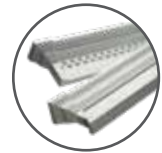

DISTINCTION CROSSHEAD OPTIONS | PAGE 12, 29



CRAFTSMAN COVE CROSSHEAD | PAGE 14, 30-31



CRAFTSMAN STEP CROSSHEAD | PAGE 16, 32



MODERN FARMHOUSE SHAKER-STYLE SHUTTERS | PAGE 18, 33



SHAKER-STYLE SHUTTERS | PAGE 20, 33



RAFTER TAILS | PAGE 22, 34



BEAM MANTELS AND SHELVES | PAGE 24, 35



STRUCTURAL POST FOR COLUMN WRAPS | PAGE 26, 35

DISTINCTION CROSSHEAD

Our Distinction Crosshead offers a modern twist on classic design, with ends that overlap the breast board to create a perfect fit.





DISTINCTION CROSSHEAD OPTIONS

Discover expanded style options for our Distinction Crosshead, now available to add an updated look to timeless design. Dentil and Bottom Trim are offered in both Ready-to-Install and Trimmable options.



CRAFTSMAN COVE CROSSHEAD

Our new Craftsman Cove Crosshead captures the look of a wood built-up Crosshead with Cove, Top and Bottom Trim. Optional End Caps are available to add an authentic Arts & Crafts style.



CRAFTSMAN STEP CROSSHEAD

The simplistic design of our Craftsman Step Crosshead emphasizes the elements of early Craftsman-style homes.



MODERN FARMHOUSE SHAKER-STYLE SHUTTERS

Discover casual, practical design with a modern twist.
Our new Modern Farmhouse Shaker-style Shutters
deliver an authentic look with subtle elegance.





SHAKER-STYLE SHUTTERS

Add grace and charm to any home with our new Shaker-style Shutters. The 2-flat recessed panel stile and rail construction honors the timeless architectural details of both classic and modern Craftsman-style homes.





RAFTER TAILS

New Fypon® Rafter Tails feature an updated Rough Sawn Cedar finish, creating a more authentic look.

Choose from five new profile designs including Straight, Cove, Slant, Bullnose and Scroll.



BEAM MANTELS & SHELVES

Add rustic charm to the interior of any home with Fypon® Beam Mantels and Shelves. Choose from two realistic wood grains, Rough Sawn or Hand Hewn.



STRUCTURAL POST KIT FOR FYPON® COLUMN WRAPS

We now offer a Structural Post Kit that pairs perfectly with our Column Wraps. The Structural Post has a load-bearing capacity of 5,000 lbs., and can be used in lieu of a 4" x 4" pre-treated wood post.



DISTINCTION CROSSHEAD

Ready-to-Install

- Our extended Distinction Crosshead line includes heights measuring 6" and 9". Widths for 6" high Crossheads are available from 24" - 144", and widths for 9" Crossheads are available from 24" - 216", both in 1" increments.
- End Cap comes standard with 1 1/2" width and overlaps Crosshead.
- End Caps may be routed.
- Optional Keystone, Dentil and Bottom Trim are factory applied.

6" & 9" Distinction Crosshead



Distinction Crosshead with Coordinating Pilaster Widths

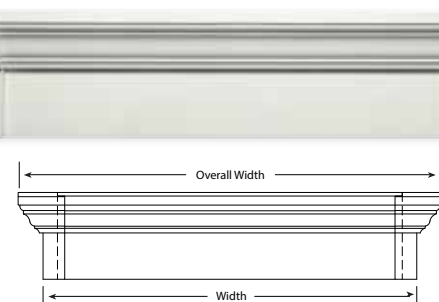

Part Number Logic:

[Profile]		[Configuration]	
CH = Crosshead	EC = End Cap	BT = Bottom Trim	D = Dentil Trim
		K = Keystone	R = Routed
[Breast Board Width] (1" increments)		[Height]	
24 = 24" [Minimum]	6 = 6"	7 = 7" (BT option only)	9 = 9"
144 = 144" [Maximum for 6" high]	7 = 7" (BT option only)	9 = 9"	10 = 10" (BT option only)
216 = 216" [Maximum for 9" high]	10 = 10" (BT option only)		

Part Number Logic:

[Profile]		[Pilaster Width*]	
CH = Crosshead	EC = End Cap	5 = 5 1/4"	7 = 7"
		7 = 7"	9 = 9"
[Crosshead Width]		[Crosshead Height]	
51 = 51"	66 = 66"	74 = 74"	86 = 86"
53 = 53"	67 = 67"	77 = 77"	88 = 88"
54 = 54"	68 = 68"	78 = 78"	93 = 93"
56 = 56"	69 = 69"	80 = 80"	96 = 96"
58 = 58"	70 = 70"	81 = 81"	9 = 9"
64 = 64"	72 = 72"	84 = 84"	

* The last character in the part number coordinates with the Pilaster width.

Trimmable

- Distinction Trimmable Crossheads are available in heights measuring 6" and 9", and widths measuring 36", 48", 144" and 216".
 - 36" and 48" widths allow for ease of handling and quick installation.
 - 144" and 216" widths can be cut to any length, minimizing waste in the field.
- End Cap overlaps the Trimmable Crosshead.
- End Caps may be routed.

6" Distinction Crosshead & End Caps

Part Number	Overall Width (A)	Width (B)	Rabbet Width (C)
CHC2X6	3 1/4"	1 1/2"	1/2"
CHC2X6-5*			
CHC4X6	5 1/4"	3 1/2"	1"
CHC4X6-5*			
CHC7X6^	8 3/4"	7"	4"
CHC7X6-5*^			
CHC11X6^	12 3/4"	11"	4"
CHC11X6-5*^			

Note: Sold in pairs. *Pack quantity of 5 pair. ^Trimmable up to 3 1/2".

9" Distinction Crosshead & End Caps

Part Number	Overall Width (A)	Width (B)	Rabbet Width (C)
CHC2X9	4 1/4"	1 1/2"	1/2"
CHC2X9-5*			
CHC4X9	6 1/4"	3 1/2"	1"
CHC4X9-5*			
CHC7X9^	9 3/4"	7"	4"
CHC7X9-5*^			
CHC11X9^	13 3/4"	11"	4"
CHC11X9-5*^			

Note: Sold in pairs. *Pack quantity of 5 pair. ^Trimmable up to 3 1/2".



How to Order

- 1 Determine height.
- 2 Determine breast board width of Crosshead.
- 3 Select End Cap width. End Cap widths should coordinate with Pilaster or Moulding on either side of door / window. If no Moulding is used, then any End Cap can be selected.
- 4 Calculate Trimmable Crosshead; account for End Cap. Crosshead breast board width - (End Cap Back Surface X 2) = Trimmable Crosshead
- 5 Select Trimmable Crosshead.
- 6 Optional: Select Accessory Moulding / Keystone.

Example

- 6" high
- 36" width
- CHC4X6 (Coordinating over 3 1/2" Flat Trim)
- 36" - (2.5" x 2) = 31" required
- CHT36X6
- K6M and MLD716-12

*End Cap Back Surface

End Cap	End Cap Breast Width (A)	End Cap Back Surface (B)	Rabbet Width (C)
CHC2	1 1/2"	1"	1/2"
CHC4	3 1/2"	2 1/2"	1"
CHC7	7"	3"	4"
CHC11	7"	11"	4"

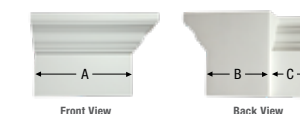

Distinction Accessories

Accessory	6" Height	9" Height
Keystone	K6M	K9M
Dentil	MLD357-8	MLD358-8
Bottom Trim	MLD716-12	MLD758-12

CRAFTSMAN COVE CROSSHEAD

Ready-to-Install

- Our expanded Craftsman Cove Crosshead line includes heights measuring 9" and widths measuring 24" - 216", available in 1" increments.
- End Cap comes standard with 3 1/2" width and overlaps Crosshead.
- End Caps may be routed.

9" Craftsman Cove Crosshead

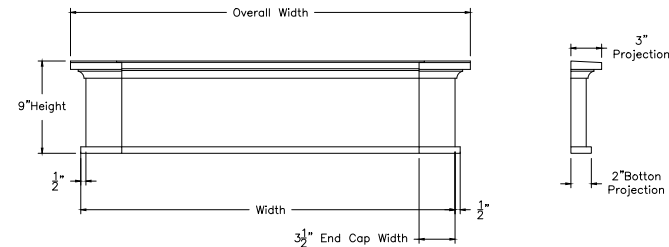

Part Number Logic:

CHCC24X9BT

[Profile]
CHCC = Crosshead Craftsman Cove

[Breast Board Width]
(1" increments)
24 = 24" [Minimum]
216 = 216" [Maximum]

[Configuration]
EC = End Cap
R = Routed

[Height]
9 = 9"

BT = Bottom Trim

If Flat Trim is to be included as part of the opening, remember the following:

- 1) Account for lighting, door bells, mailboxes or any other item that could dictate the width of the trim.
- 2) Remember to take into account brickmould, if applicable.
- 3) Breast board of the Crosshead or Crosshead End Cap should fit over both the left and right trim pieces.

Trimvable

- Our expanded Craftsman Cove Crosshead line includes a 9" height, and widths measuring 24"-216", in 1" increments.
- Optional End Caps are available in widths measuring 3 1/2" and 5 1/2" to complement standard trim sizes, and overlap Crosshead.
- Crosshead and End Caps may be routed.

9" Craftsman Cove Crosshead

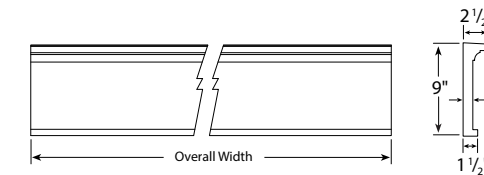

Part Number	Overall Width
CHCCT36X9BT	36"
CHCCT48X9BT	48"
CHCCT144X9BT	144"
CHCCT216X9BT	216"

End Caps are optional.



How to Order

- 1 Determine height.
- 2 Determine breast board width. When installing over side trim CHCCC6X9BT coordinates best with 5 1/4" Pilaster and 5 1/2" wide trim.
- 3 Select End Cap width.

9" Craftsman Cove End Caps



3 1/2" End Cap

5 1/2" End Cap

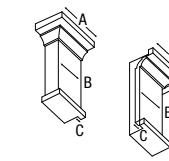

Bottom View

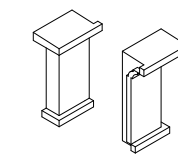

Top View

Part Number	Overall Width (A)	Width (B)	Rabbit Width (C)
CHCCC4X9BT	5"	3 1/2"	1/2"
CHCCC4X9BT-5*			
CHCCC6X9BT	7"	5 1/2"	1/2"
CHCCC6X9BT-5*			

* Pack quantity of 5 pair.
End Caps overlap the Trimvable Crosshead.

CRAFTSMAN STEP CROSSHEAD

Trimmable

6" Craftsman Step Crosshead

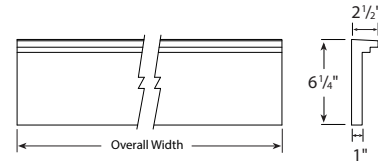

Part Number	Overall Width	Height
CHCST36X6	36"	6 1/4"
CHCST48X6	48"	6 1/4"
CHCST144X6	144 3/8"	6 1/4"
CHCST216X6	216 5/8"	6 1/4"

Part may be routed.

8" Craftsman Step Crosshead

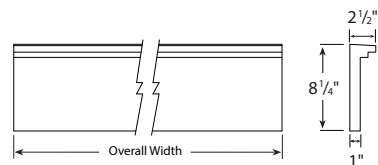

Part Number	Overall Width	Height
CHCST36X8	36"	8 1/4"
CHCST48X8	48"	8 1/4"
CHCST144X8	144 3/8"	8 1/4"
CHCST216X8	216 5/8"	8 1/4"

Part may be routed.

MODERN FARMHOUSE SHAKER-STYLE SHUTTERS

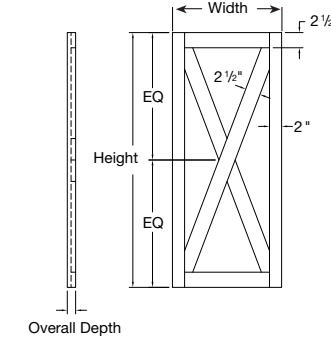

- Available in widths measuring 12", 16", 18" and 24", and heights measuring 24" - 120" in 1" increments.
- 2" wide stiles and 2 1/2" wide batten create the X batten design.
- Stiles 1 3/8" deep with 5/8" recessed panel
- Modern Farmhouse Shaker-style Shutter Panels and Flat Trim are available to meet your design needs (SHSFP12X144, SHSFP16X144, SHSFP18X144, SHSFP24X144, FLT1X3-12).

Part Number Logic:

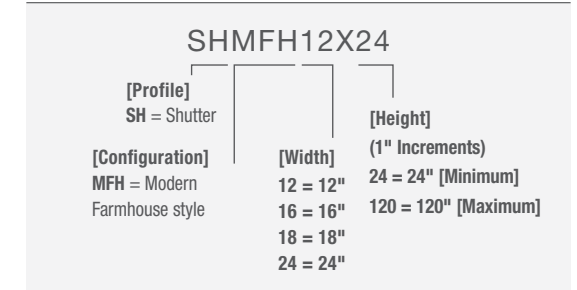

Note: Sold in pairs.

SHAKER-STYLE SHUTTERS

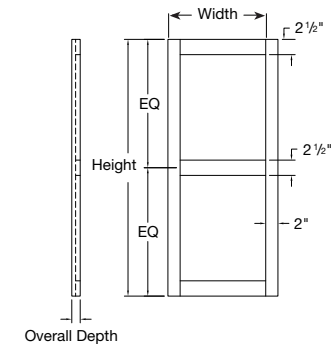

- 2-panel flat recessed stile and rail design.
- Available in widths measuring 12", 16", 18" and 24", and heights measuring 24" - 120" in 1" increments.
- 2" wide stiles with 2 1/2" wide rails. Center rail is positioned in the center of the shutter.
- Stiles 1 3/8" deep with 5/8" recessed panel.
- Shaker-style Shutter Panels and Flat Trim are available to meet your design needs (SHSFP12X144, SHSFP16X144, SHSFP18X144, SHSFP24X144, FLT1X3-12).

Part Number Logic:

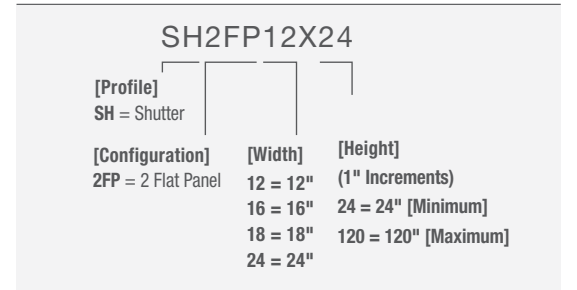

Note: Sold in pairs.

RAFTER TAILS

How to Order

- 1 Select profile design.
- 2 Select size.
- 3 Optional: Select pitch angle needed.
- 4 Select pack quantity.*

- New Rafter Tails are available in five profile designs: Straight, Cove, Slant, Bullnose and Scroll.
- Available in heights measuring 5 1/2" (6" nominal) and 7 1/2" (8" nominal).
- 6 Projections: 12", 18", 24", 30", 36", 42".
- Optional back cut pitch angles: 4/12, 6/12, 8/12, 10/12 and 12/12.
- Quantities: 4 Pack, 10 Pack.



Straight Profile	Cove Profile	Slant Profile	Bullnose Profile	Scroll Profile
BMRTST4X6X12RS	BMRTCV4X6X12RS	BMRTSL4X6X12RS	BMRTBL4X6X12RS	BMRTSC4X6X12RS
BMRTST4X6X18RS	BMRTCV4X6X18RS	BMRTSL4X6X18RS	BMRTBL4X6X18RS	BMRTSC4X6X18RS
BMRTST4X6X24RS	BMRTCV4X6X24RS	BMRTSL4X6X24RS	BMRTBL4X6X24RS	BMRTSC4X6X24RS
BMRTST4X6X30RS*	BMRTCV4X6X30RS*	BMRTSL4X6X30RS*	BMRTBL4X6X30RS*	BMRTSC4X6X30RS*
BMRTST4X6X36RS*	BMRTCV4X6X36RS*	BMRTSL4X6X36RS*	BMRTBL4X6X36RS*	BMRTSC4X6X36RS*
BMRTST4X6X42RS*	BMRTCV4X6X42RS*	BMRTSL4X6X42RS*	BMRTBL4X6X42RS*	BMRTSC4X6X42RS*
BMRTST4X8X18RS	BMRTCV4X8X18RS	BMRTSL4X8X18RS	BMRTBL4X8X18RS	BMRTSC4X8X18RS
BMRTST4X8X24RS	BMRTCV4X8X24RS	BMRTSL4X8X24RS	BMRTBL4X8X24RS	BMRTSC4X8X24RS
BMRTST4X8X30RS*	BMRTCV4X8X30RS*	BMRTSL4X8X30RS*	BMRTBL4X8X30RS*	BMRTSC4X8X30RS*
BMRTST4X8X36RS*	BMRTCV4X8X36RS*	BMRTSL4X8X36RS*	BMRTBL4X8X36RS*	BMRTSC4X8X36RS*
BMRTST4X8X42RS*	BMRTCV4X8X42RS*	BMRTSL4X8X42RS*	BMRTBL4X8X42RS*	BMRTSC4X8X42RS*

Note: All parts have open cavity. *Longer rafter tails are only available in pack quantities of 4.

Optional Pitch Adder:

Pack Quantity Adder:

4/12 = P4 6/12 = P6 8/12 = P8 10/12 = P10 12/12 = P12

-4PK -10PK

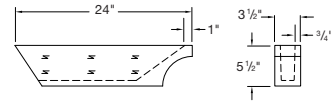

Part Number Logic (Pitch required):

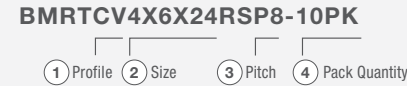

*Longer Rafter Tails are only available in pack quantities of 4.

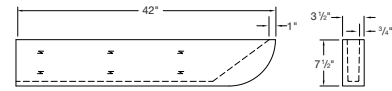

Part Number Logic (No Pitch needed):

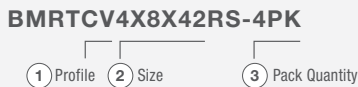

*Longer Rafter Tails are only available in pack quantities of 4.



BEAM MANTELS

Sizes:

- Available in 6" x 8" and 8" x 10" with lengths measuring 60" - 90", in 6" increments.

Beam Mantel Testing:

- Fypon polyurethane beam mantels were tested to ASTM D1929 – IGNITION TEMPERATURE EVALUATION ON BEAM MANTEL POLYURETHANE FOAM USING FOAMRESIN-R MATERIAL, and shown to be safe from ignition at a temperature of 300 degrees Celsius or 572 degrees Fahrenheit. As a comparison, wood (soft woods, such as pine, cedar, redwood, fir, etc.) will ignite at 180 degrees Celsius or 300 degrees Fahrenheit.

Weight Load Capacity:

- Testing by a third-party lab showed a weight load capacity of 200 lbs.

Note: When installed according to Fypon Beam Mantel Installation Instructions.

Hand Hewn



Part Number

BMH6X8X60ELM-EC
 BMH6X8X66ELM-EC
 BMH6X8X72ELM-EC
 BMH6X8X78ELM-EC
 BMH6X8X84ELM-EC
 BMH6X8X90ELM-EC
 BMH8X10X60ELM-EC
 BMH8X10X66ELM-EC
 BMH8X10X72ELM-EC
 BMH8X10X78ELM-EC
 BMH8X10X84ELM-EC
 BMH8X10X90ELM-EC

Rough Sawn



Part Number

BMR6X8X60CDR-EC
 BMR6X8X66CDR-EC
 BMR6X8X72CDR-EC
 BMR6X8X78CDR-EC
 BMR6X8X84CDR-EC
 BMR6X8X90CDR-EC
 BMR8X10X60CDR-EC
 BMR8X10X66CDR-EC
 BMR8X10X72CDR-EC
 BMR8X10X78CDR-EC
 BMR8X10X84CDR-EC
 BMR8X10X90CDR-EC

STRUCTURAL POST FOR COLUMN WRAPS

Description	Height	Part Number
Aluminum Structural Post with a load-bearing capacity of 5,000 lbs. Kit includes aluminum post, 4 x 4 post mount and screws.	96"	STRPOSTKIT96
	108"	STRPOSTKIT108
	120"	STRPOSTKIT120





1750 Indian Wood Circle | Maumee, OH 43537 | Phone: 800.446.3040 U.S. and Canada
Fax: 800.446.9373 U.S. and Canada | www.fypon.com | info@fypon.com



Fypon warrants all of our products to be free from defects in material and workmanship for as long as the original owner of the residential dwelling owns the property. For complete homeowner lifetime limited warranty details, exclusions and limitations, please see your purchase location or visit www.fypon.com.

©2018 Fypon, LLC. All rights reserved. Fypon and the Fypon Logo are trademarks of Fypon, LLC. Fypon, LLC, and its parent company Therma-Tru Corp. are part of Fortune Brands Home & Security, Inc. All trademarks are property of their respective owners.

Publication No. MAFYNG2019 METZ / DEC 2018