

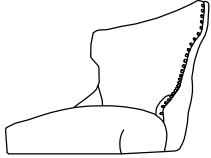







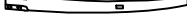
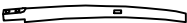
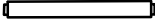
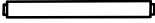

ASSEMBLY INSTRUCTION

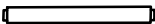
E491-24(N1) / E491-29(N1) COUNTER / BAR HEIGHT STOOL

A Chair Body	B Front Left Leg	C Front Right Leg	D Left Rear Leg
1pc 	1pc 	1pc 	1pc 
E Right Rear Leg	F Front Stretcher	G Left Stretcher	H Right Stretcher
			
1pc I Rear Stretcher	1pc J Bolt Ø8x55mm	1pc K Bolt Ø8x50mm	1pc L Lock Washer Ø8x13mm
			
1pc M Flat Washer Ø8x22mm	4pcs N Allen Key M5	4pcs O Screw M4x45mm	8pcs P Screwdriver (Not Provided)
			
8pcs	1pc	8pcs	1pc

E491-24(N1)

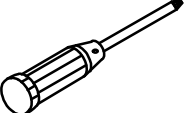
E491-29(N1)

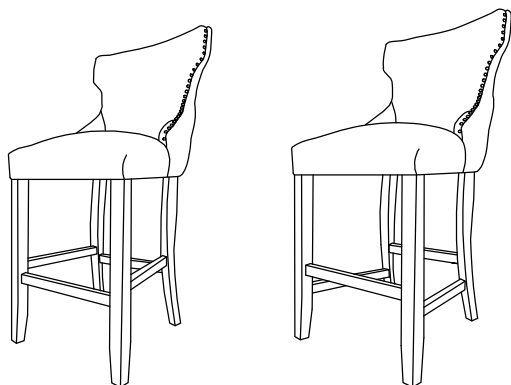

This page lists all the contents included in the box. Please take the time to identify the hardware as well as the individual components to this product. As you unpack and prepare for assembly, place the contents on a carpeted or padded area to protect them from damage.

- 1** Attach Front Stretcher (F) to Front Left Leg (B) & Front Right Leg (C), then attach Front Left Leg (B) and Front Right Leg (C) to the Chair Body (A) using Bolt (J), Lock Washer (L) and Flat Washer (M) on both holes of Chair Body (A) by Allen Key (N). Turn the Allen Key (N) in Bolt (J). But not too tight.

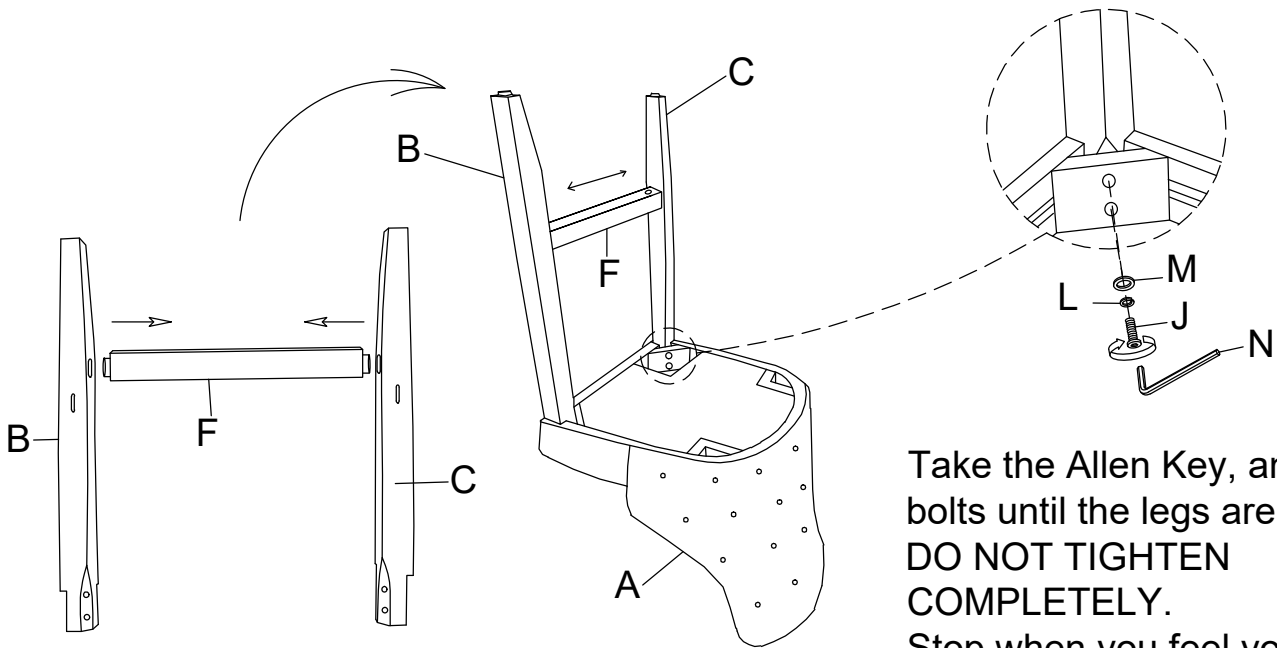

Take the Allen Key, and turn the bolts until the legs are secure. **DO NOT TIGHTEN COMPLETELY.** Stop when you feel you are adding force to tighten the bolt.

- 2** First, attach the Rear Stretcher (I) to the Left Rear Leg (D) & Right Rear Leg (E). Then attach them to the Chair Body (A) using Bolt (K), Lock Washer (L), Flat Washer (M) in both holes of Chair Body (A). Turn the Allen Key (N) in Bolt (K). But not too tight. Second, attach Right Stretcher (H) to Front Right Leg (C) & Right Rear Leg (E), and attach Left Stretcher (G) to Front Left Leg (B) & Left Rear Leg (D) as below shown.

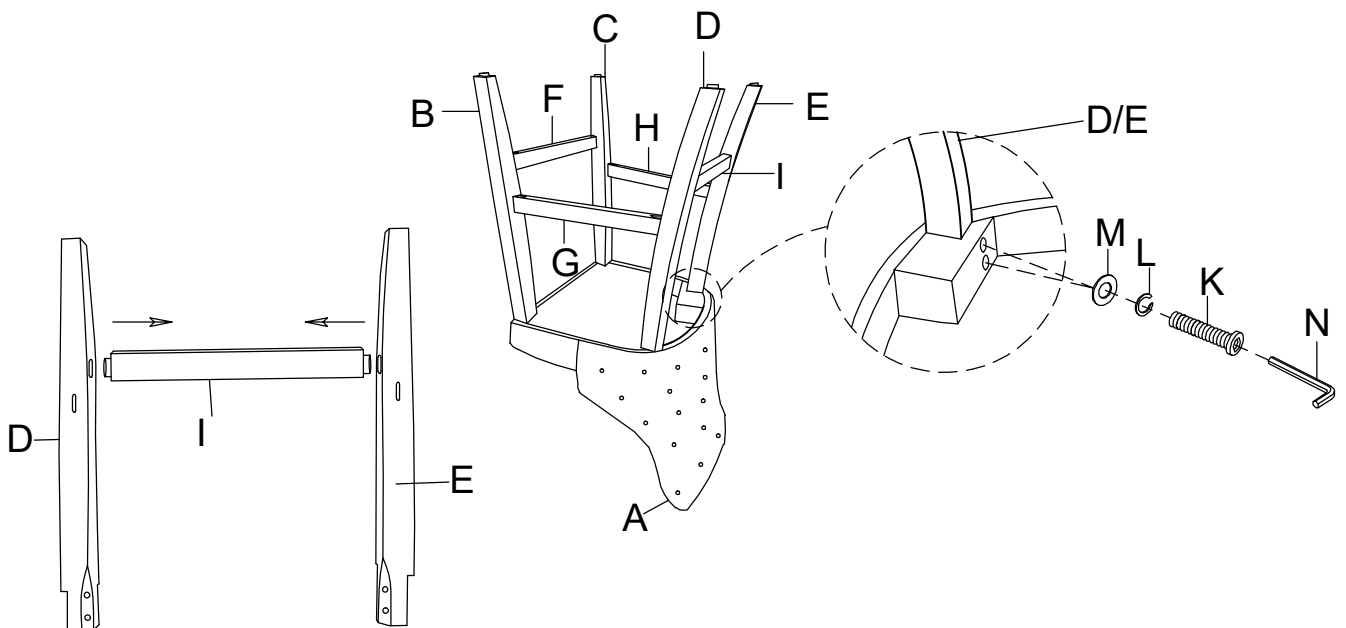

3 Using Screw (O) by Screwdriver (P) to tighten all stretchers as below shown.

Stand chair up on an even surface and check that it is balanced. If there is a slight wobble, apply downward pressure in the corner where a leg is uneven. Keeping pressure in that corner, tighten all bolts. If balanced, apply downward pressure evenly in the center and tighten all bolts. Do not over-tighten beyond hole depth.

P (Not Provided)

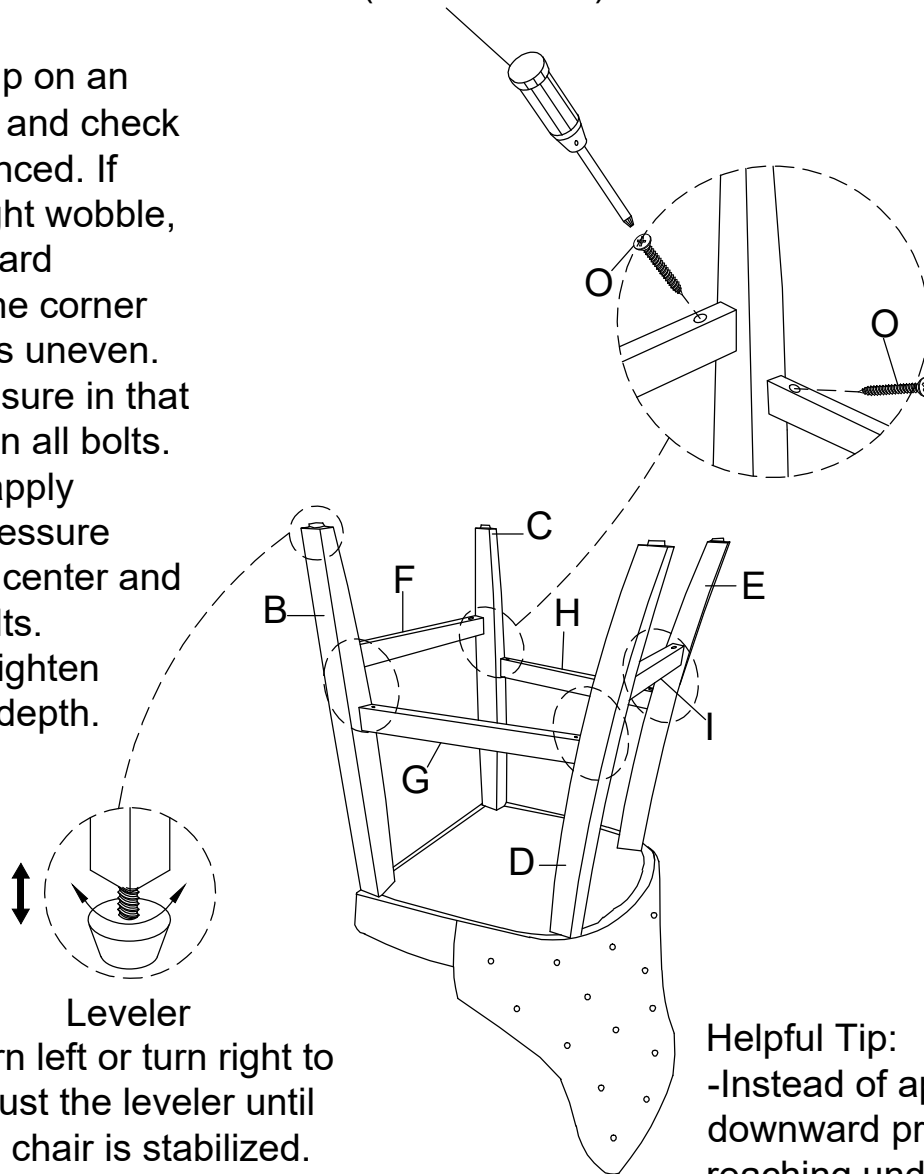

Helpful Tip:
-Instead of applying downward pressure while reaching under to tighten bolts, have someone sit in the chair while you tighten the bolts.

Cleaning & Care

Treat surface with care. Surface is resistant to scratches but is not scratch resistant. Clean surfaces with a dry or damp soft cloth. Do not use abrasive cleaners. Hardware may loosen over time. Periodically check that all connections are tight.