

# FLEXSTEEL®

## W1020 - 90Q1 / 90Q2 / 90R3

### Queen Panel Bed

#### IMPORTANT

Carefully remove all parts from the carton, and put them individually on a soft cloth to prevent damage to the parts.

We have taken great care in the design of this product and request that you carefully and accurately follow our assembly instructions to ensure proper set-up.

A Phillips Head Screwdriver is required for assembly (Not Provided)

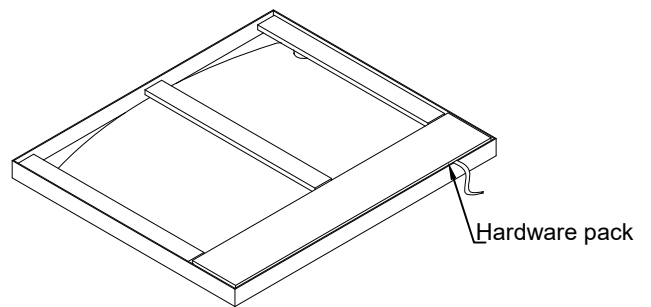
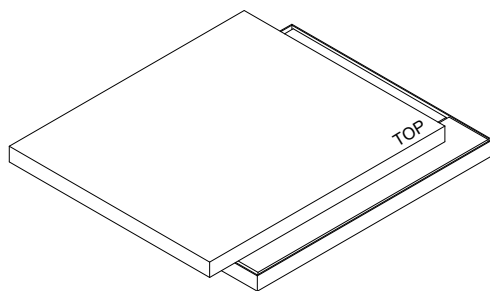
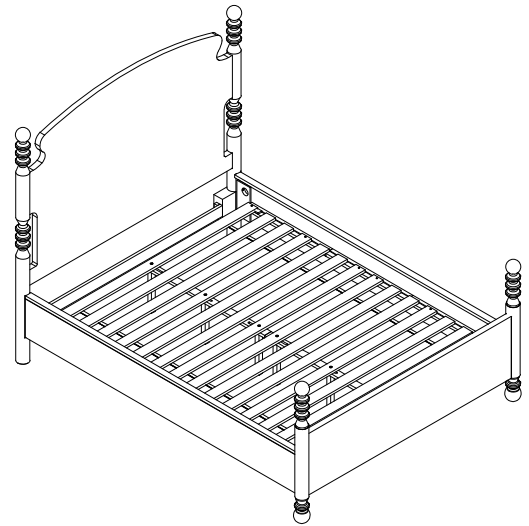

#### Part List

#### Assembly Instructions 1/4

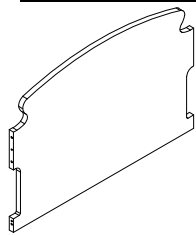

A. Headboard Panel  
1 piece

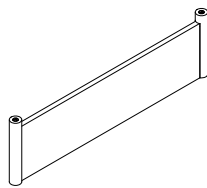

B. Footboard Panel  
1 piece

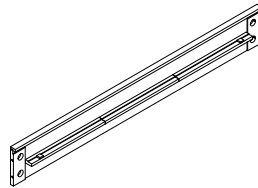

C. Side rail  
2 pieces



D. Footboard  
Upper Post  
2 pieces



E. Footboard  
Lower Post  
2 pieces



F. Headboard  
Left Post  
1 piece



G. Headboard  
Right Post  
1 piece

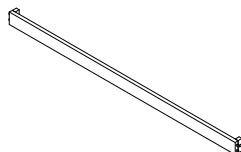

H. Headboard  
Bottom Rail  
1 piece

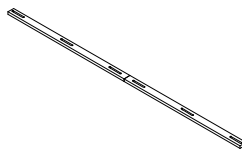

I. Center Rail  
1 piece

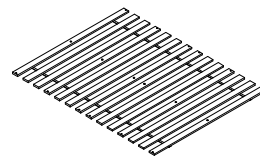

J. Roll Slats  
1set



K. Slat Support  
6 pieces

#### Hardware List

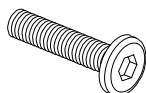

Bolt  
Ø5/16" x 18 UNC x 1-3/4"  
8 pieces



Spring Washer  
Ø5/16" x 1.5mm  
8 pieces



Flat Washer  
Ø5/16" x Ø19 x 1.5mm  
8 pieces

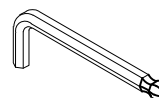

Hex Key  
5/32"  
1 piece



Screw  
#4 x 1-1/4"  
12 pieces

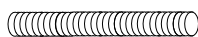

Thread Bolt  
Ø5/16" x 18 UNC x 3-1/2"  
8 pieces



Curved Washer  
1" x 5/8" x 1/16"  
8 pieces



Hexagonal Nut  
Ø5/16" x 1/2"  
8 pieces

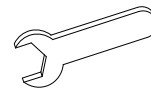

Spanner Wrench  
1/2"  
1 pieces

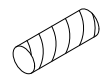

Wooden Dowel  
Ø10mm x 1-1/4"  
4 pieces

# FLEXSTEEL®

## Assembly Instructions 2/4

### IMPORTANT NOTES

- Do not tighten up all the bolts until each part is properly assembled.
- Keep the Hex Key and Spanner Wrench in a safe place as you may need to tighten up the bolts in the future.
- Use a soft cloth between these parts and the floor.
- We recommend this product be assembled by at least two adults.

### STEP 1

Fix Headboard Left Post (D) and Headboard Right Post (E) to Headboard Panel (A) and Headboard Bottom Rail (H). Insert Wooden Dowels, Bolts, Spring Washers, Flat Washers and fully tighten bolts with the Hex Key. (See Figure 1)

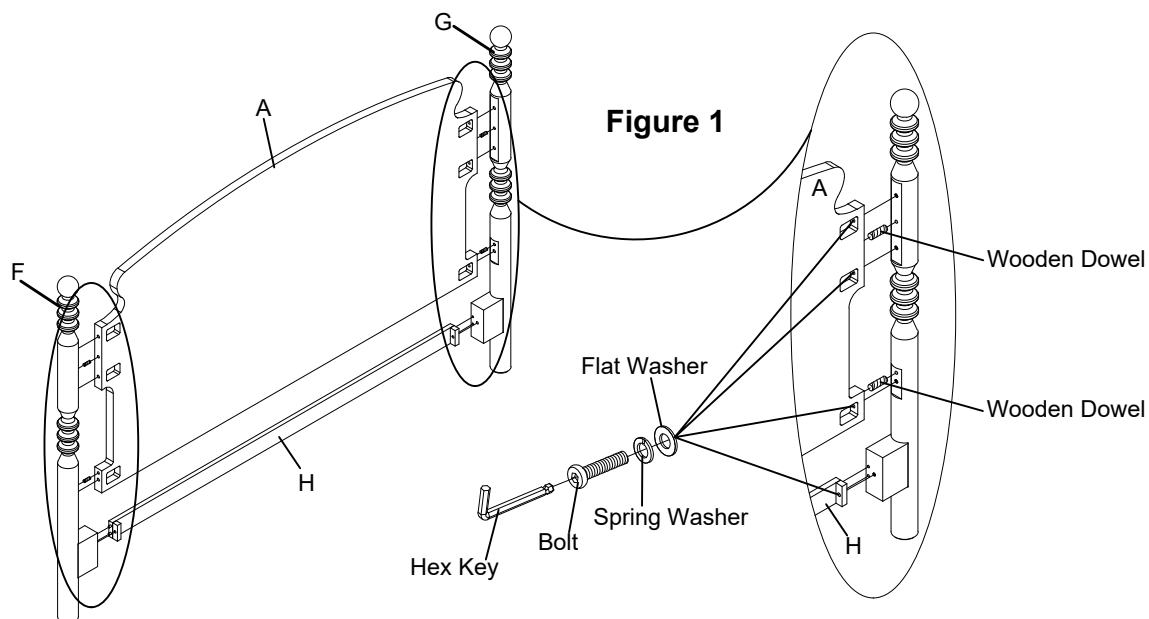

### STEP 2

Connect the Footboard Upper Post (D) and Footboard Lower Post (E) to the Footboard Panel (B) by turning by hand clockwise until tight. (See Figure 2)

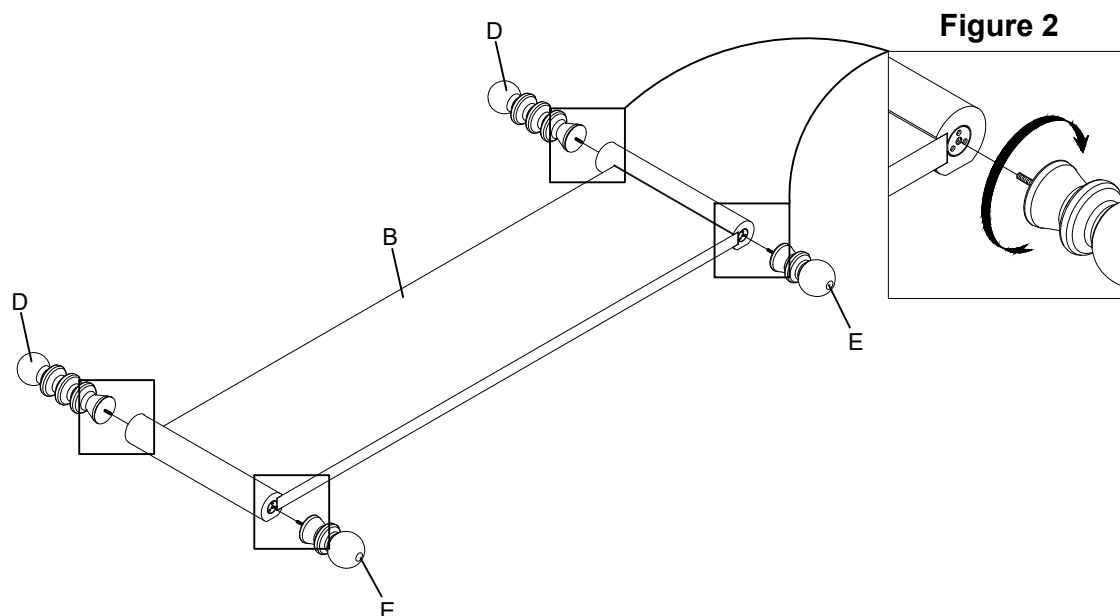

# FLEXSTEEL®

## Assembly Instructions 3/4

### STEP 3

Connect the Side rails (C) to Headboard Post (F) and (G) and Footboard Panel (B). Insert Thread Bolts, Curved Washers, Hexagonal Nuts and fully tighten bolts with Spanner Wrench. (See Figure 3)

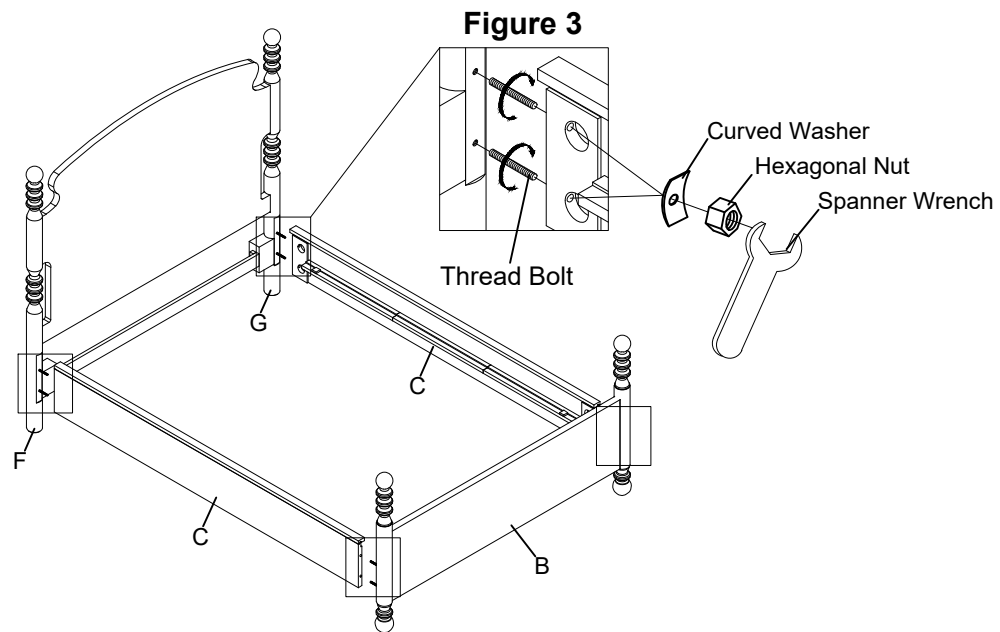

### STEP 4

Connect the Slat Supports (K) and Center Rail (I) to Roll Slats (J) by passing the bolt on the Slat Supports (K) through the slots in the Center Rails (I), and rotating them by hand clockwise until tight. (See Figure 4)

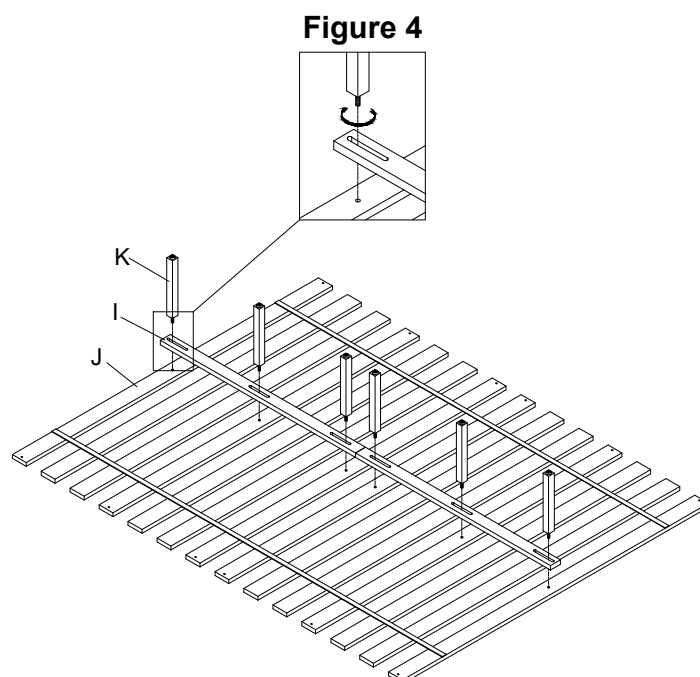

# FLEXSTEEL®

## Assembly Instructions 4/4

### STEP 5

Fix Roll Slats (J) to Side rails (C). Insert Screws.  
(See Figure 5)

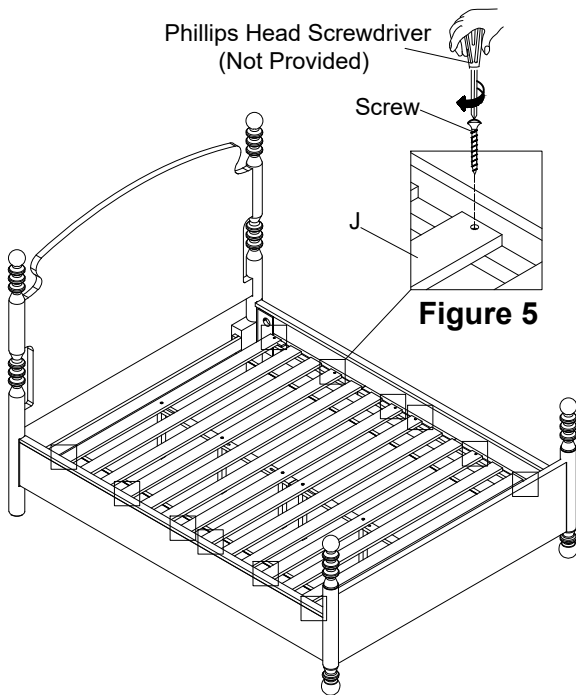

### STEP 6

Adjust the levelers on the Slat Supports (K) to ensure they are all touching the floor and ensure the Roll Slats (J) are flat. (See Figure 6)

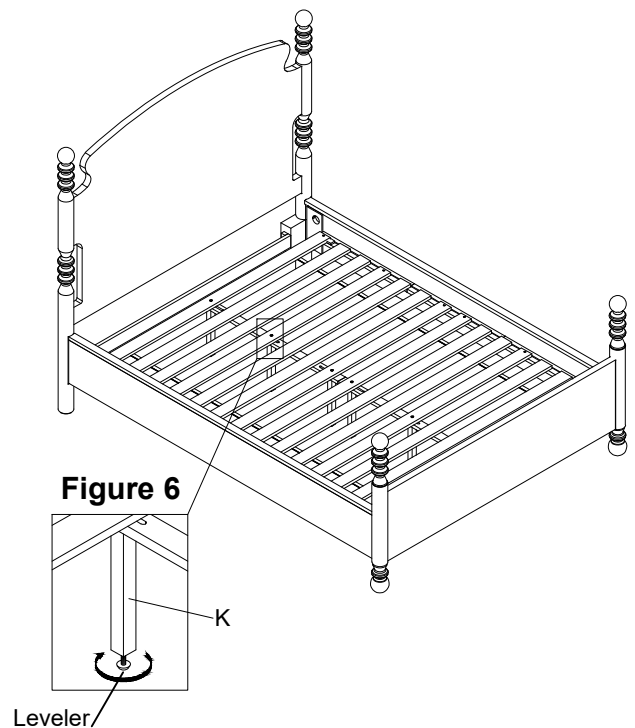

### CARE INSTRUCTIONS

- To avoid scratches, do not place sharp or jagged objects directly on the bed.
- Do not place hot items directly on the bed.
- Avoid the use of harsh chemicals or abrasive cleaning materials.
- Wipe the bed clean with a soft, dry cloth after each use.
- Wipe up spills quickly with a soft, dry cloth.

Flexsteel Industries, Inc.

For Parts or Customer Service call

toll-free:

1-888-415-3979

Monday-Friday

8:00 a.m. -5:00 p.m.

(Central Time)

Email:

customersolutions@flexsteel.com

www.flexsteel.com