

**WALKER EDISON**  
TM

# Lee Tall Chest

SKU: LEEB3B-T  
LOT: **AAYYWW-XXX**

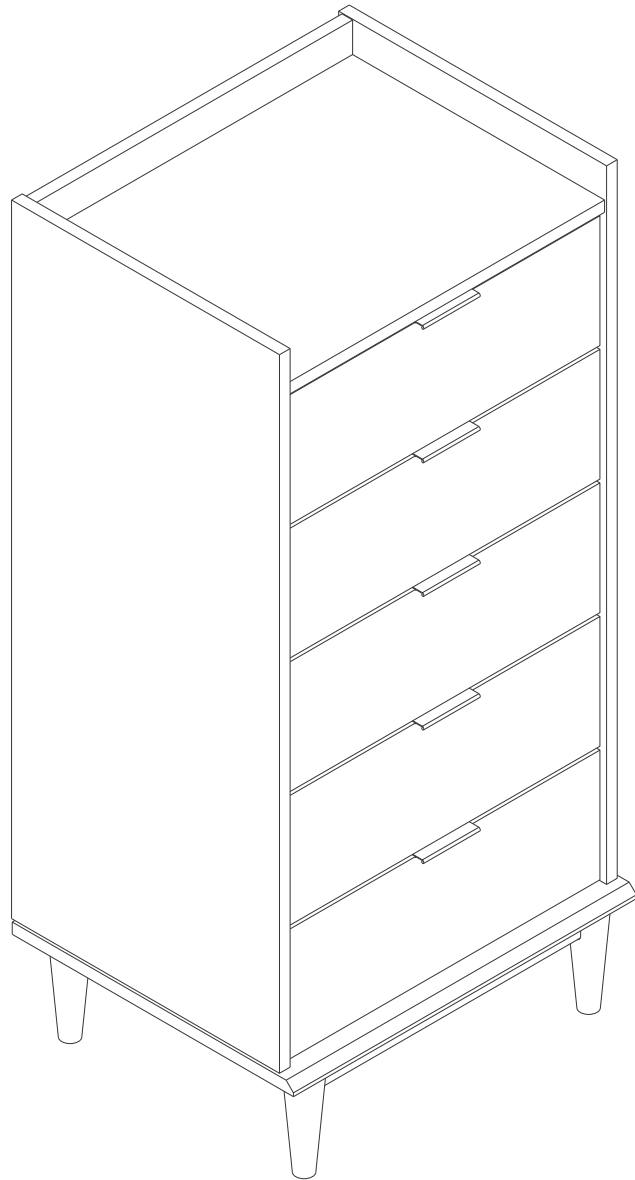

*For Residential Use Only*

Please visit our website for the most current instructions, assembly tips, to report damage, or request parts. [www.walkeredison.com](http://www.walkeredison.com)

# WE Time to get started

Set up a clean and soft workplace to avoid damage during assembly. You can use the box and internal protections as cover. It also helps to double-check if you've got all the pieces and parts before diving in assembly.

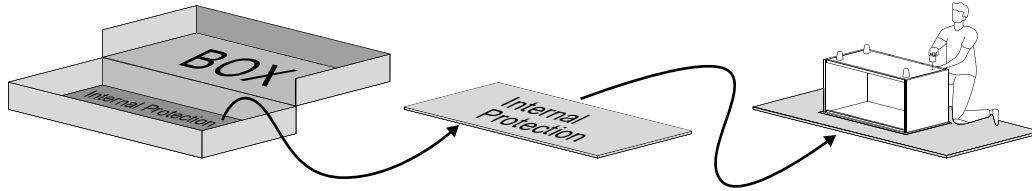

**Estimated time  
for assembly**

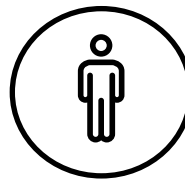

1 Person Build

**You can assemble  
it alone.**

But you can make  
it a team effort!  
Grab a friend for quicker,  
easier assembly.

## Tools Needed

Grab a Phillips head screwdriver to conquer this assembly.

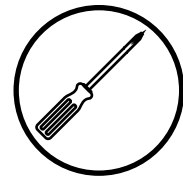

## Use power tools with caution

This furniture is made of Solid Wood and Composite Wood, soft materials. If you choose to use power tools, set it to the slower setting. Be careful! Power tools can cause cracking or damage to the furniture, they can also damage the hardware if misused. Power tool damages are not covered by the Walker Edison warranty

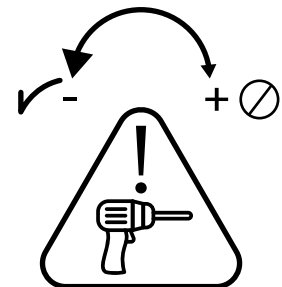

## Slide care

Your furniture has highly durable wooden sliders. From time to time we recommend applying paraffin or standard candle wax to improve gliding of the sliders.

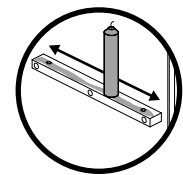

**Scan to get assembly tips and help!**

# WE Part List

Part Number	Description	Quantity
01	Top panel	01
04	Bottom panel	01
05	Left drawer side	05
06	Right drawer side	04
07	Right drawer side (warning)	01
08	Drawer front	05
10	Drawer back	05
15	Top rail	01
16	Back panel	01

Part Number	Description	Quantity
17	Wood slider	10
34	Bottom front rail	02
35	Bottom side rail	02
36	Foot	04
42	Left side panel	01
43	Right side panel	01
44	Center rail	01
48	Drawer bottom	05

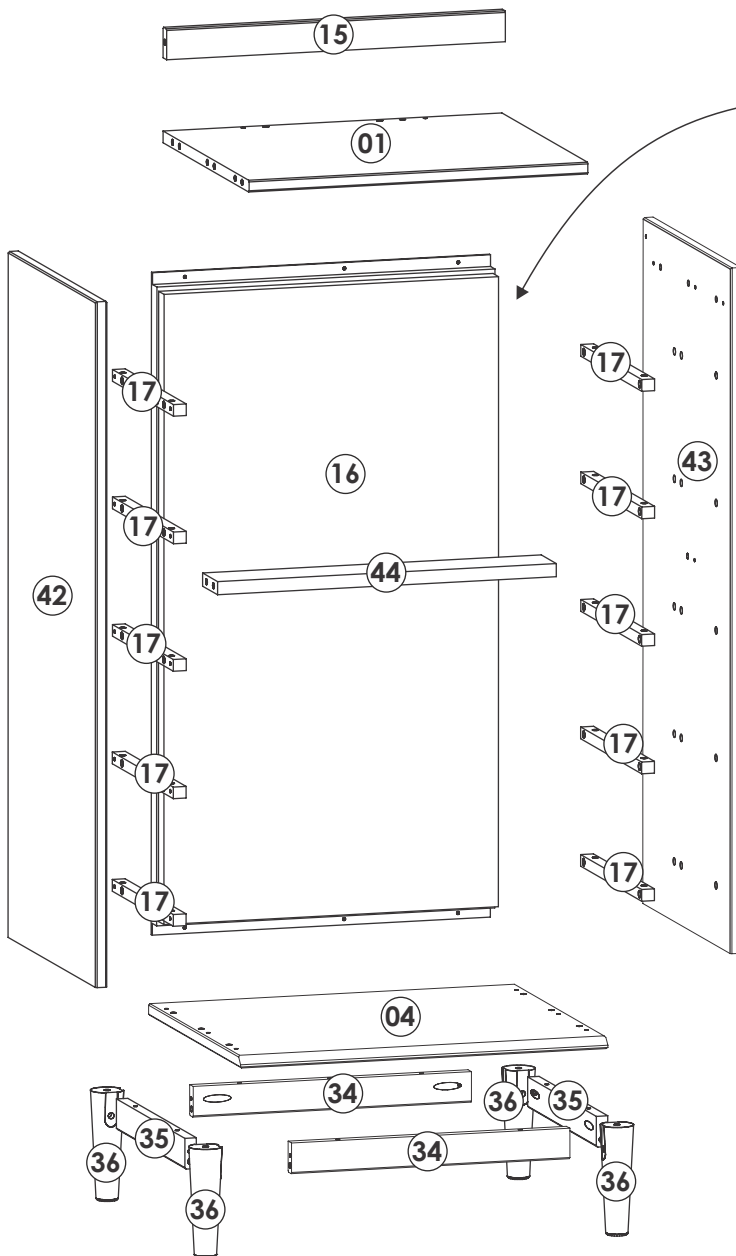

**WALKER EDISON**  
 Distribution and responsible for the anti-tip hardware:  
 Walker Edison Furniture Company  
 1553 W 9000 S, West Jordan,  
 UT 84088 United States

**LEE**

Model: XXXXXXXXFF  
 LOT: AAYYWW-XXX  
 Date: MM/20YY  
 Rev: MM/20YY-VX

CANFER compliant / conforme au CANFER  
 TSCA Title VI compliant / conforme au titre VI de la TSCA  
 TSCA Title VI certified / certifié conformément au titre VI de la TSCA  
 California 93120 Compliant for Formaldehyde  
 Conforme à la norme Californie 93120 pour le formaldéhyde

For details on Assembly Videos, Assembly Instructions,  
 Replacement Parts and Customer Service, SCAN HERE

**WARNING**

Children have died from furniture tipover. To reduce the risk of furniture tipover:

- ALWAYS install Anti-tip device provided.
- NEVER put a TV on this product.
- NEVER allow children to stand, climb, or hang on any drawers, doors, or shelves.
- NEVER open more than one drawer at a time.
- Place heaviest items in the lowest drawers.







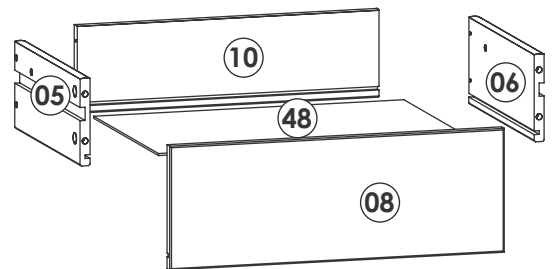





*This is a permanent label. Do not remove!*

The drawer with WARNING LABEL should be placed as the highest drawer.

**5x**

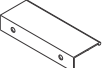

# WE Hardware List

Part	Size	Name	Quantity
A	 8x30mm	Wooden dowel	41
B	 10x20mm	Wooden dowel	30
C	 4,0x40mm	Screw	22
D	 3,0x12mm	Screw	10
E	 3,5x30mm	Screw	23
F	 15x12mm	Cam lock	30
G	 5x24mm	Cam bolt	30
H	 3,5x20mm	Screw	07
I	 8x40mm	Wooden dowel	10
J	 4,0x25mm	Screw	30
K	 6x35mm	Plastic bush	01
L		Washer	02
M		Wall anchor	01
N		Handle	05

The hardware quantities listed above are required for proper assembly.  
Extra hardware pieces may be included.

# Step 1

Let's get started! Insert Wooden dowel (B) into Wood slider (17).

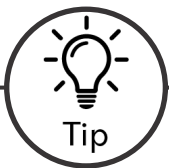
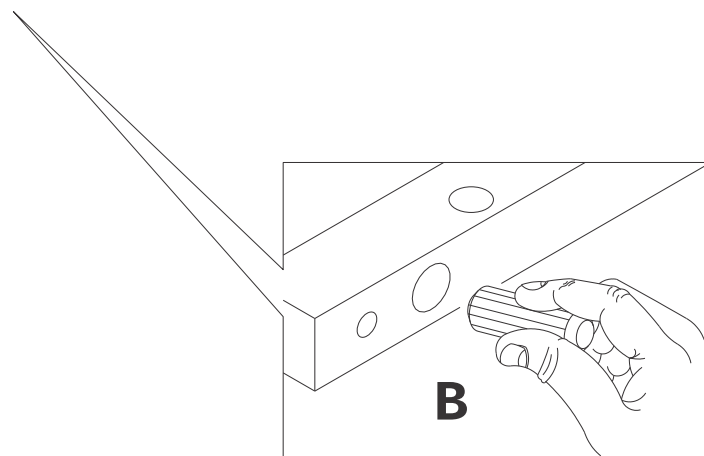
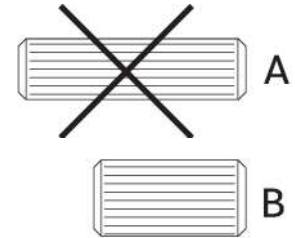
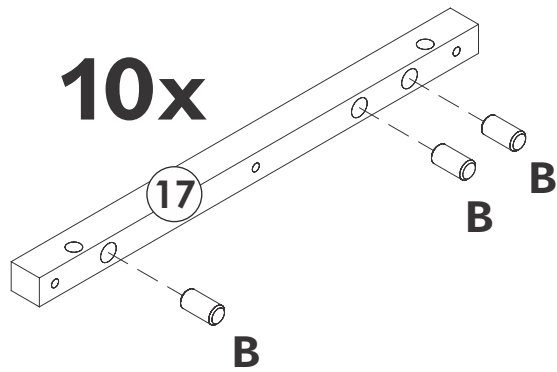
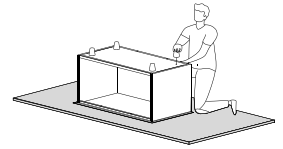

Tip

## Wood Dowels

Dowels are essential in furniture assembly to create strong, precise connections. They ensure structural integrity, prevent shifting, and simplify alignment, resulting in sturdier, longer-lasting furniture.

Follow these steps:

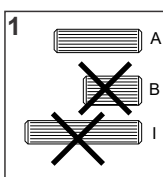

1: Select the appropriate size dowel according with step.

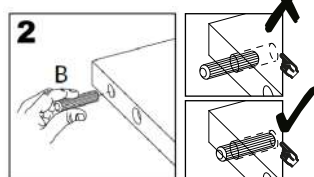

2: Insert into drilled hole and press firmly to ensure placement is set.

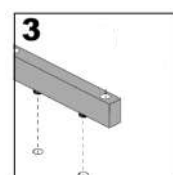

3: Align the dowel with corresponding piece and press together until secure.

# Step 2

Also insert Wooden dowels (A) into Top panel (01), Top rail (15), Bottom front rail (34), Bottom side rail (35), Foot (36), Left side panel (42) and Right side panel (43).

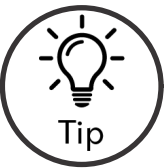
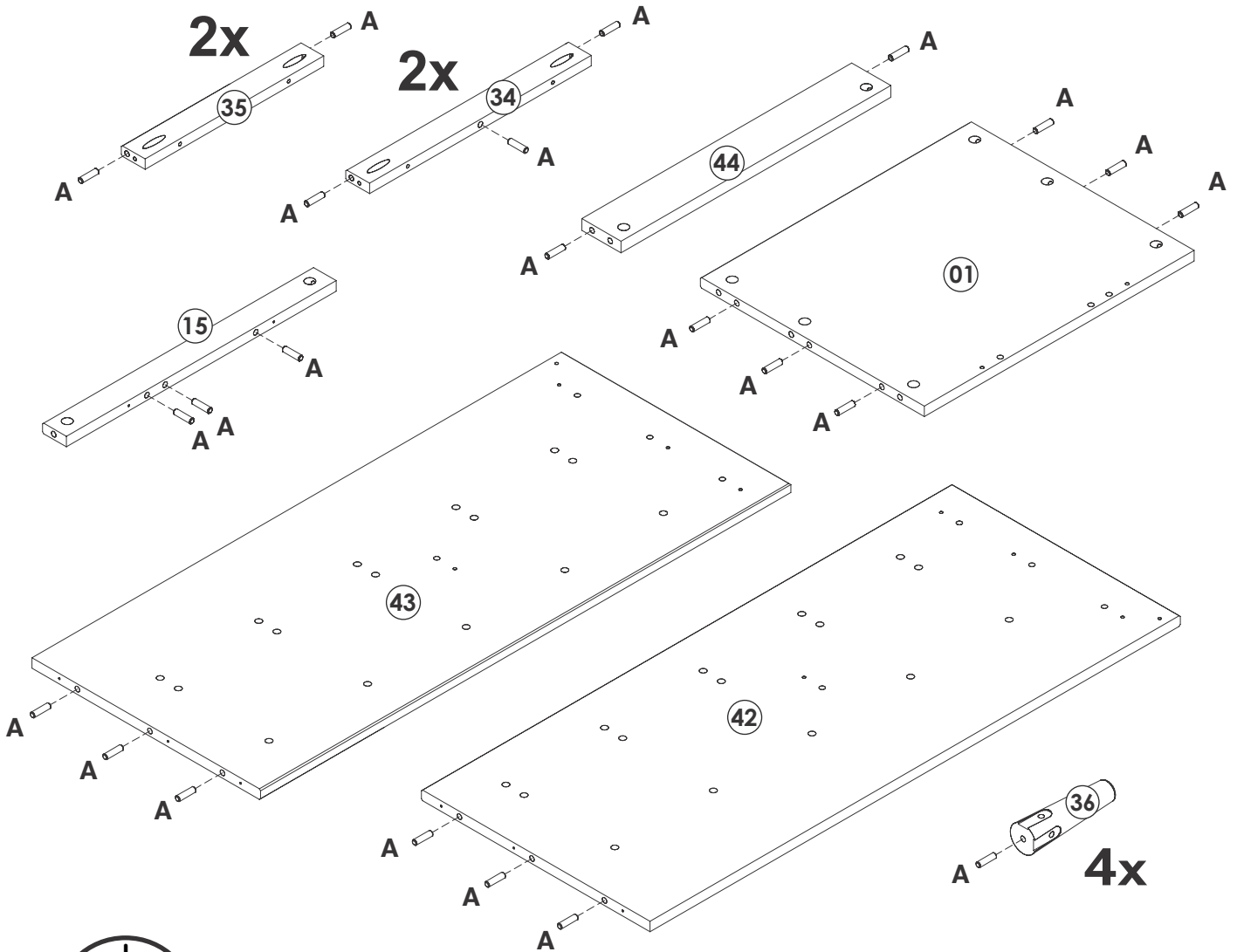

To keep your product looking its best and scratch-free, try assembling it on a soft surface like carpet or a blanket. This helps prevent any accidental scratches and keeps your furniture in top shape!

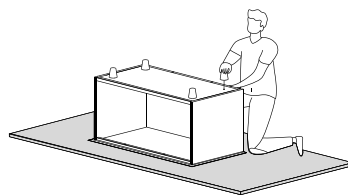

# Step 3

Attach Cam bolt (G) into the holes in Drawer front (08),  
Left side panel (42) and Right side panel (43) with  
Phillips head screwdriver.

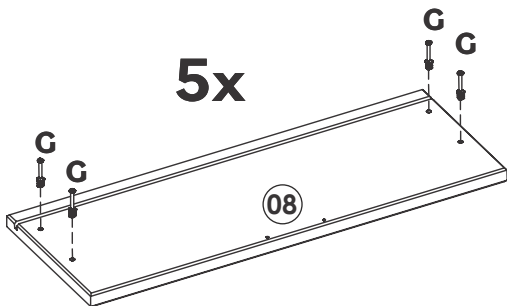
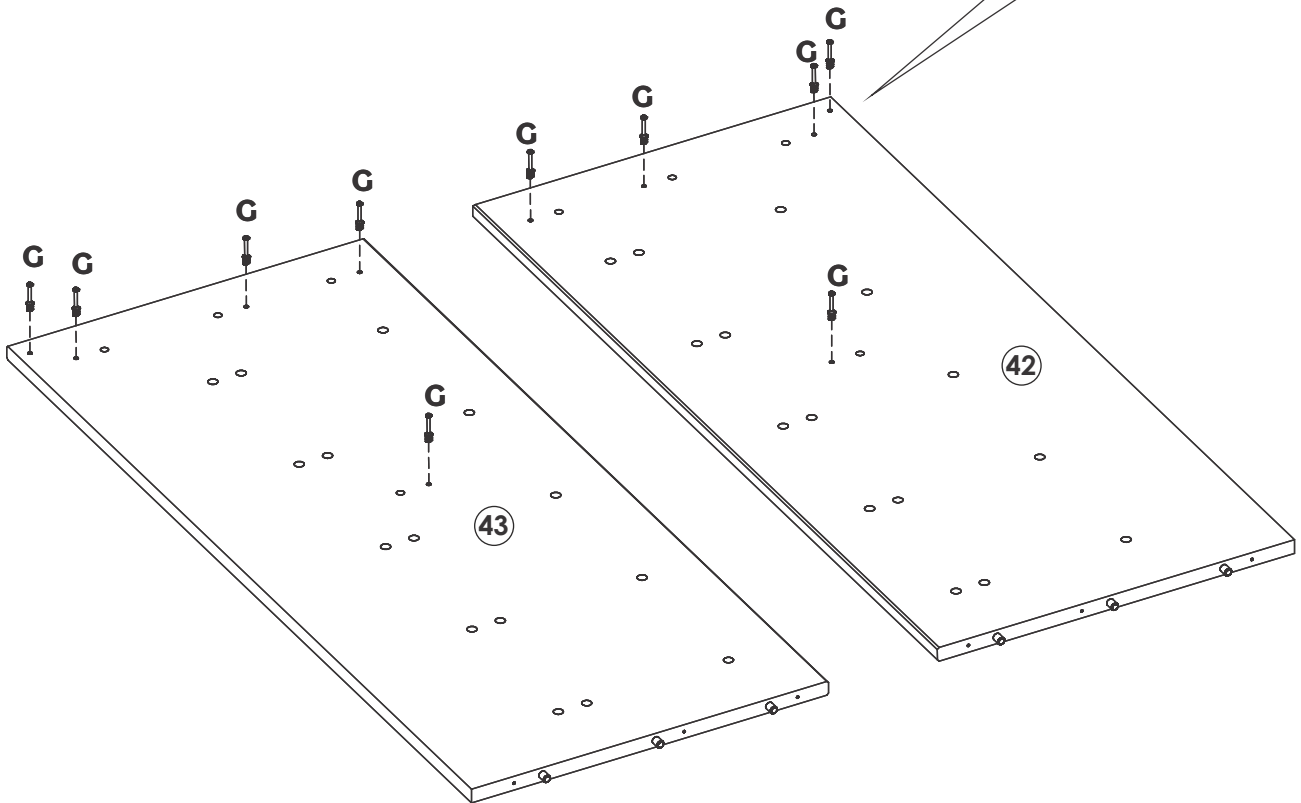
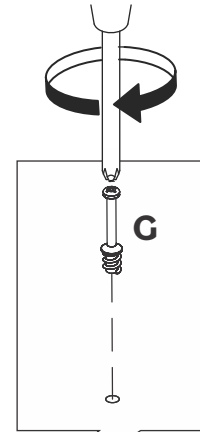
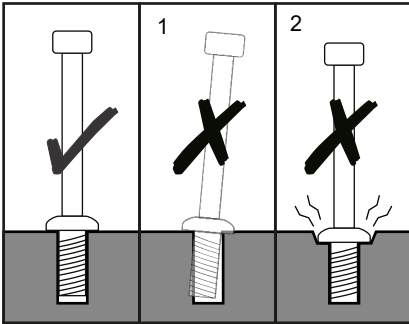
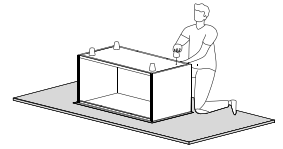

# Step 4

Secure Wood sliders (17) to Left side panel (42) and Right side panel (43) with Screw (J) and Phillips head screwdriver.

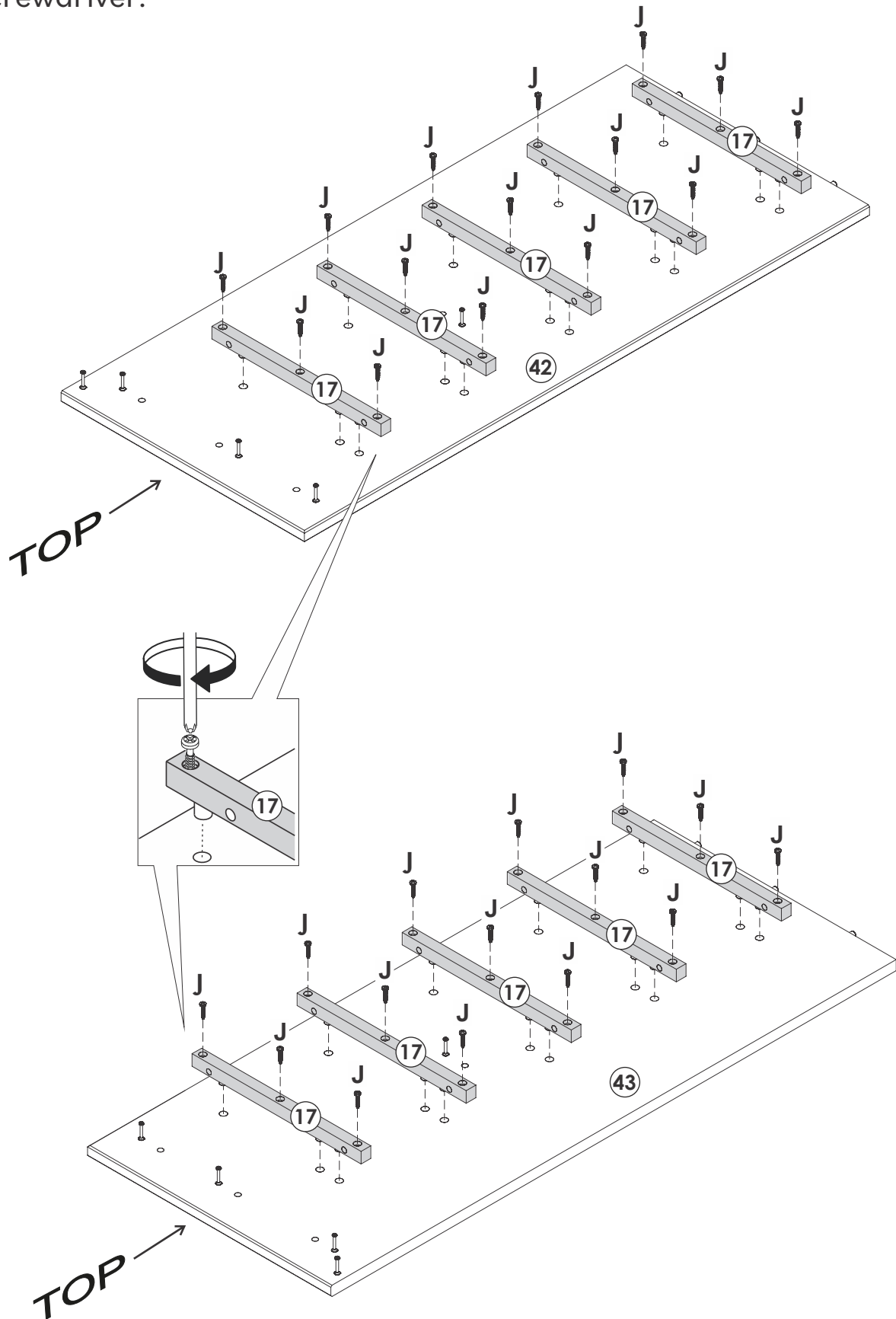
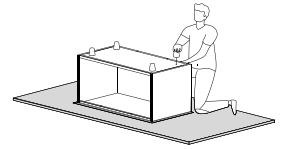



# Step 5

Secure Top rail (15) to Top panel (01) using Screw (E) and a Phillips head screwdriver.

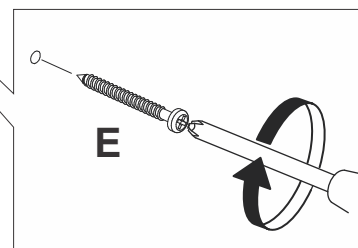
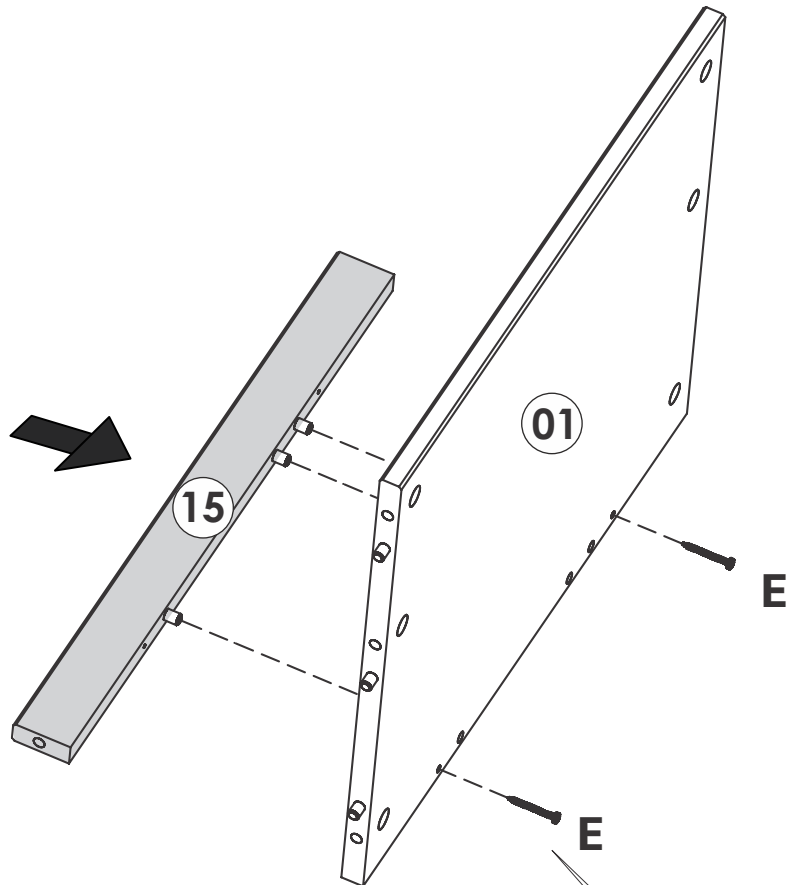
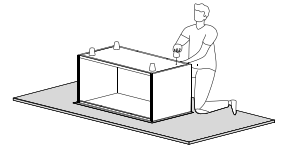

Once this step is completed, your product should look like this.

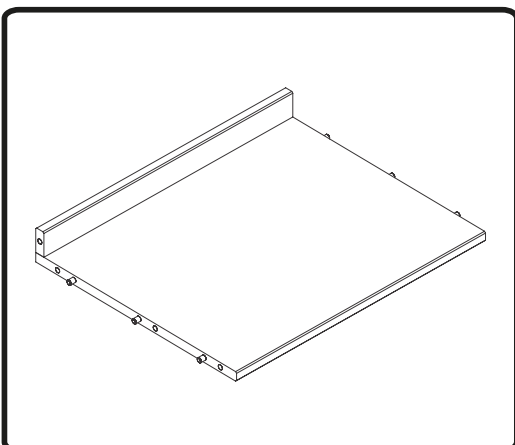

# Step 6

Assemble Top panel (01), Top rail (15) and Center rail (44) to Right side panel (43). Insert Cam lock (F) in the holes on Top panel (01) and Center rail (44) and attach with Phillips head screwdriver.

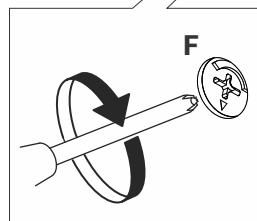
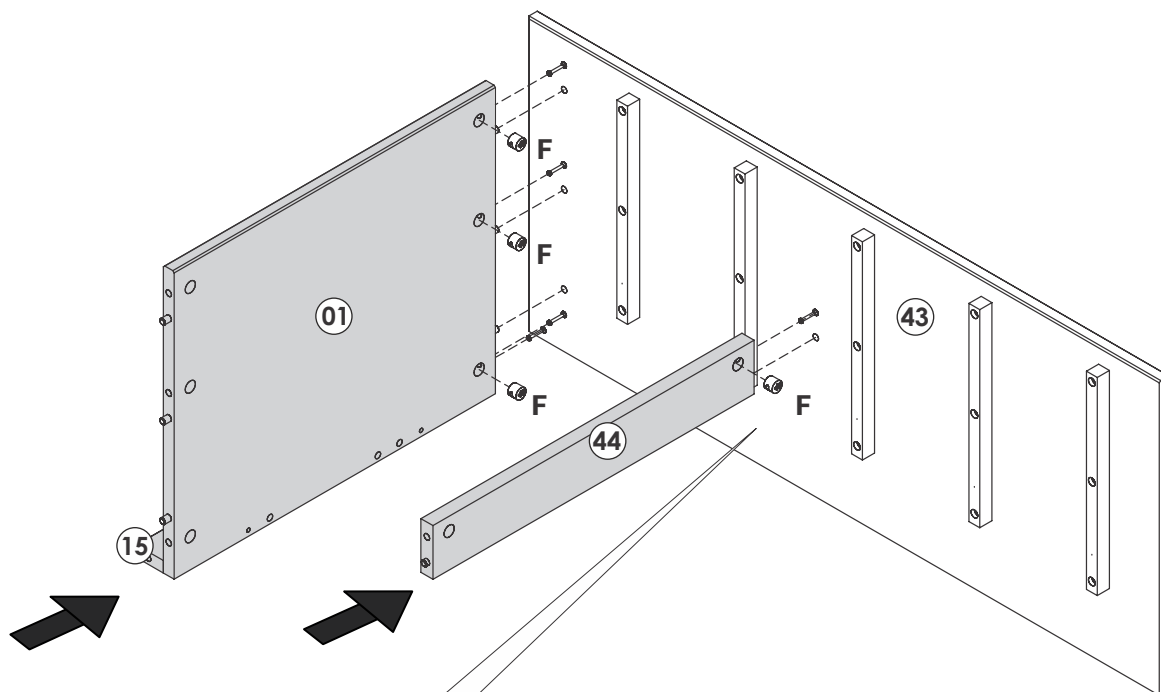
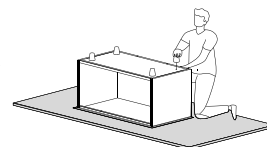

Once this step is completed, your product should look like this.

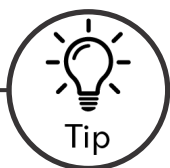
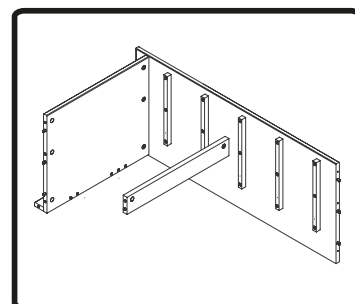

Tip

## Cam Locks

Cam Locks help securely join two pieces together. Follow these easy steps.

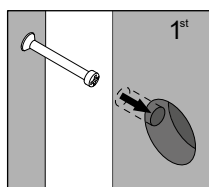

1: Insert Cam Bolt into bolt holes on the flat side. Don't over tighten!

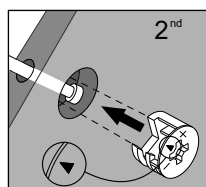

2: Assemble both parts together. The cam bolts goes in the drills holes that have a circular hole on the side, you should be able to see the cam bolt through it. After fitting parts together insert the cam lock on the side holes.

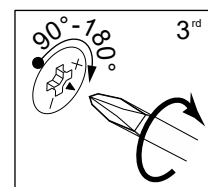

3: On the back of the Cam Lock will be a 'C' shape. Insert the Cam Lock so the opening of the 'C' fits over the Cam Bolt. Tighten with the screwdriver.

# Step 7

Join Left side panel (42) to Top panel (01), Top rail (15) and Center rail (44). Insert Cam lock (F) in the hole on Top panel (01) and Center rail (44) and attach with a Phillips screwdriver.

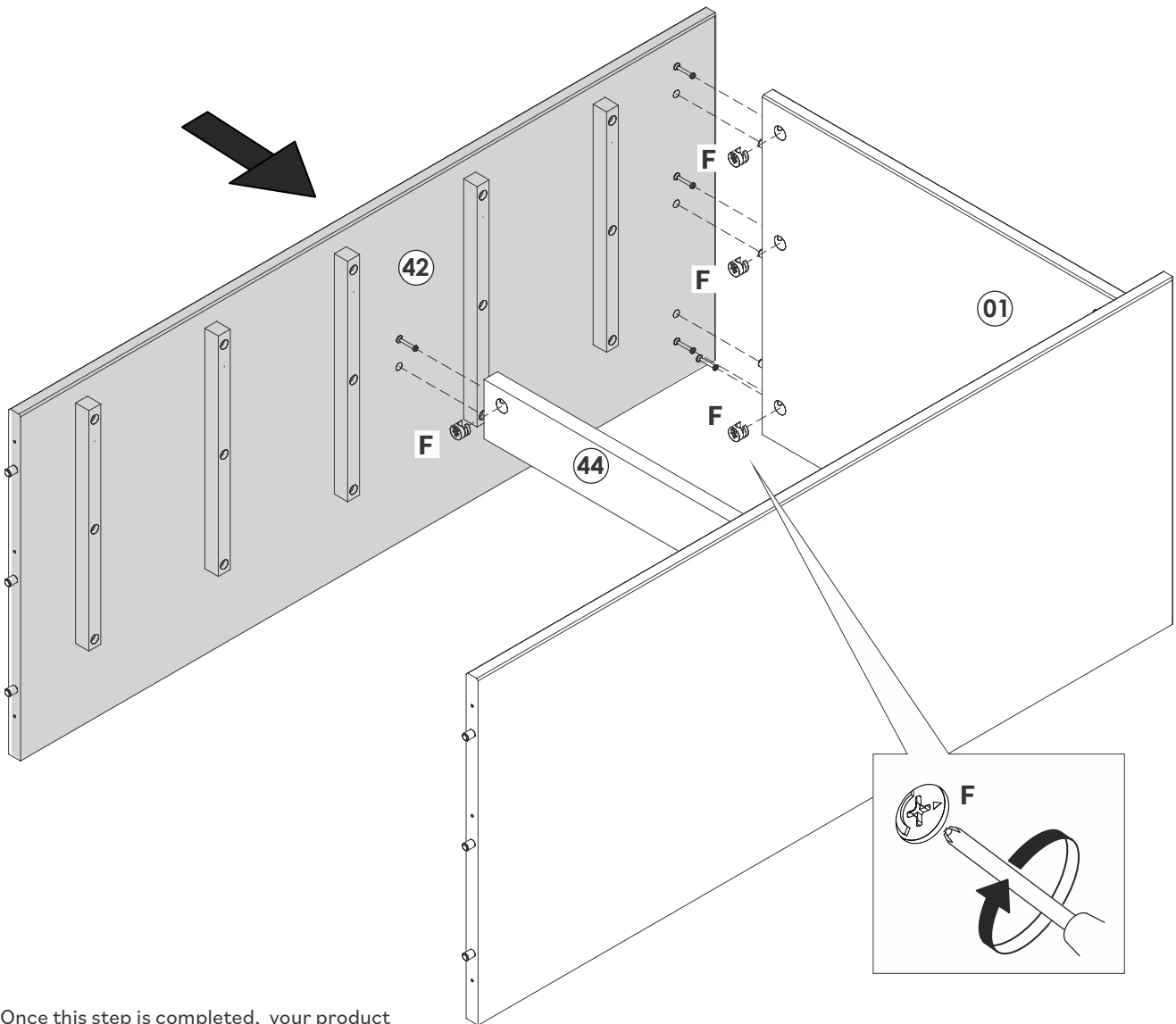
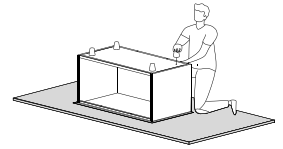

Once this step is completed, your product should look like this.

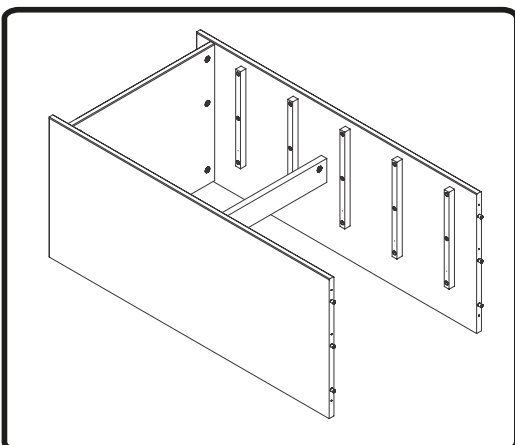

# Step 8

Secure Bottom panel (04) to Left side panel (42) and Right side panel (43) using Screw (C) and a Phillips head screwdriver.

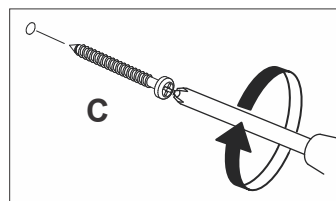
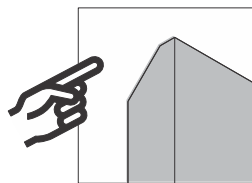
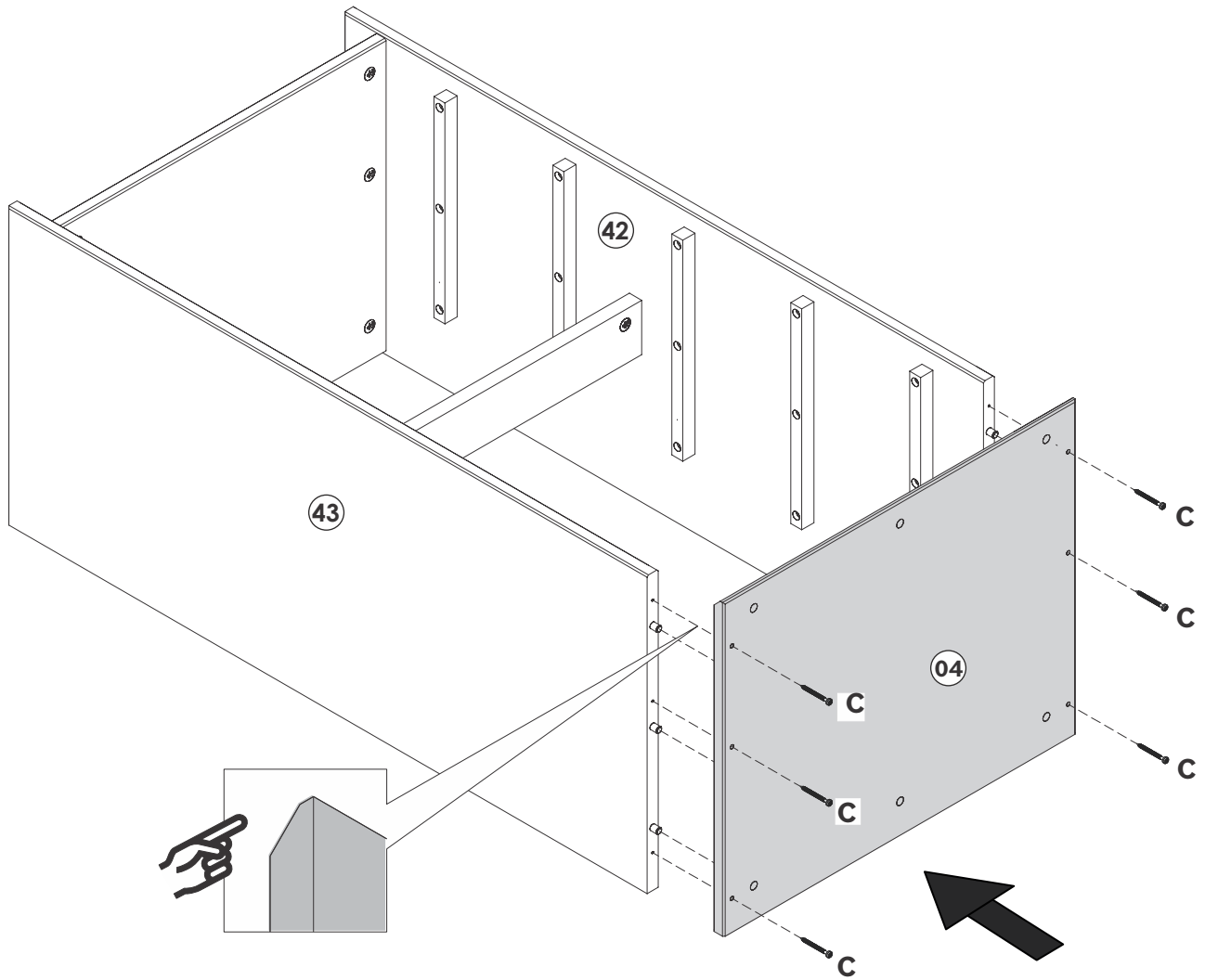
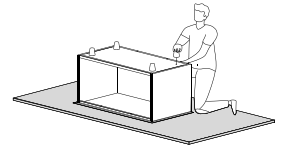

Once this step is completed, your product should look like this.

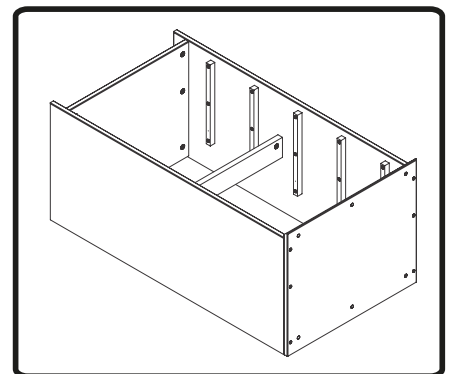

# Step 9

Secure Bottom front rail (34) to Foot (36) with Screw (C) and Phillips head screwdriver.

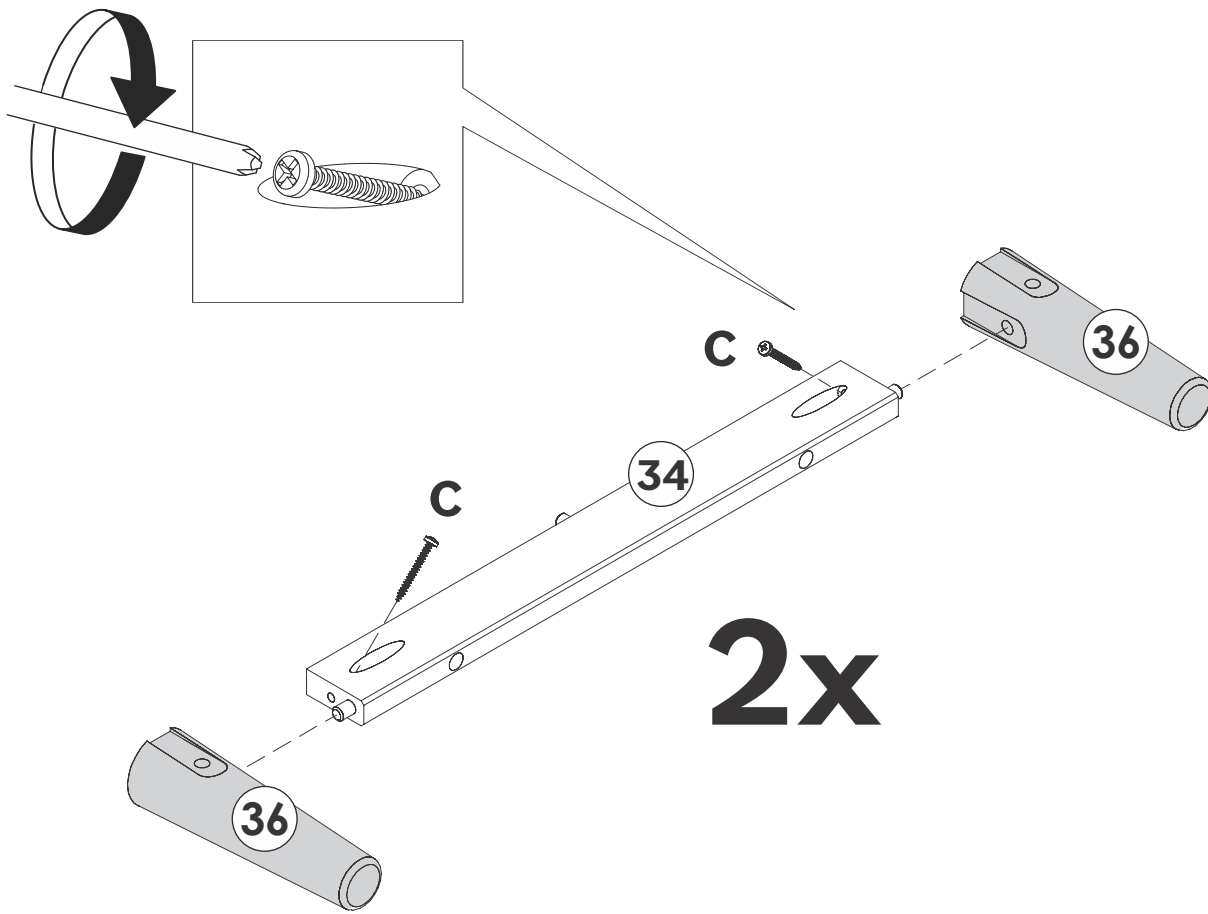
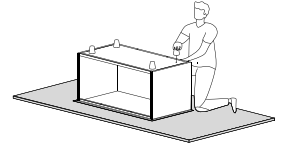

Once this step is completed, your product should look like this.

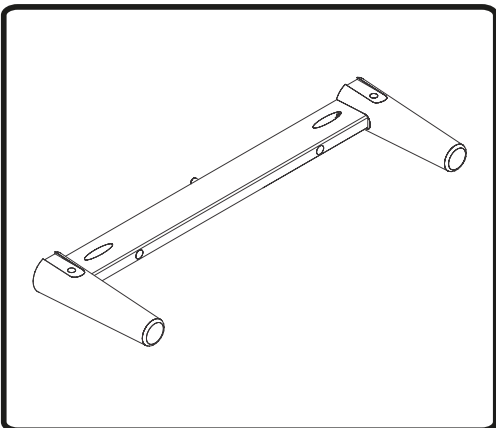

# Step 10

Secure Bottom side rail (35) to Foot (36) with Screw (C) and Phillips head screwdriver.

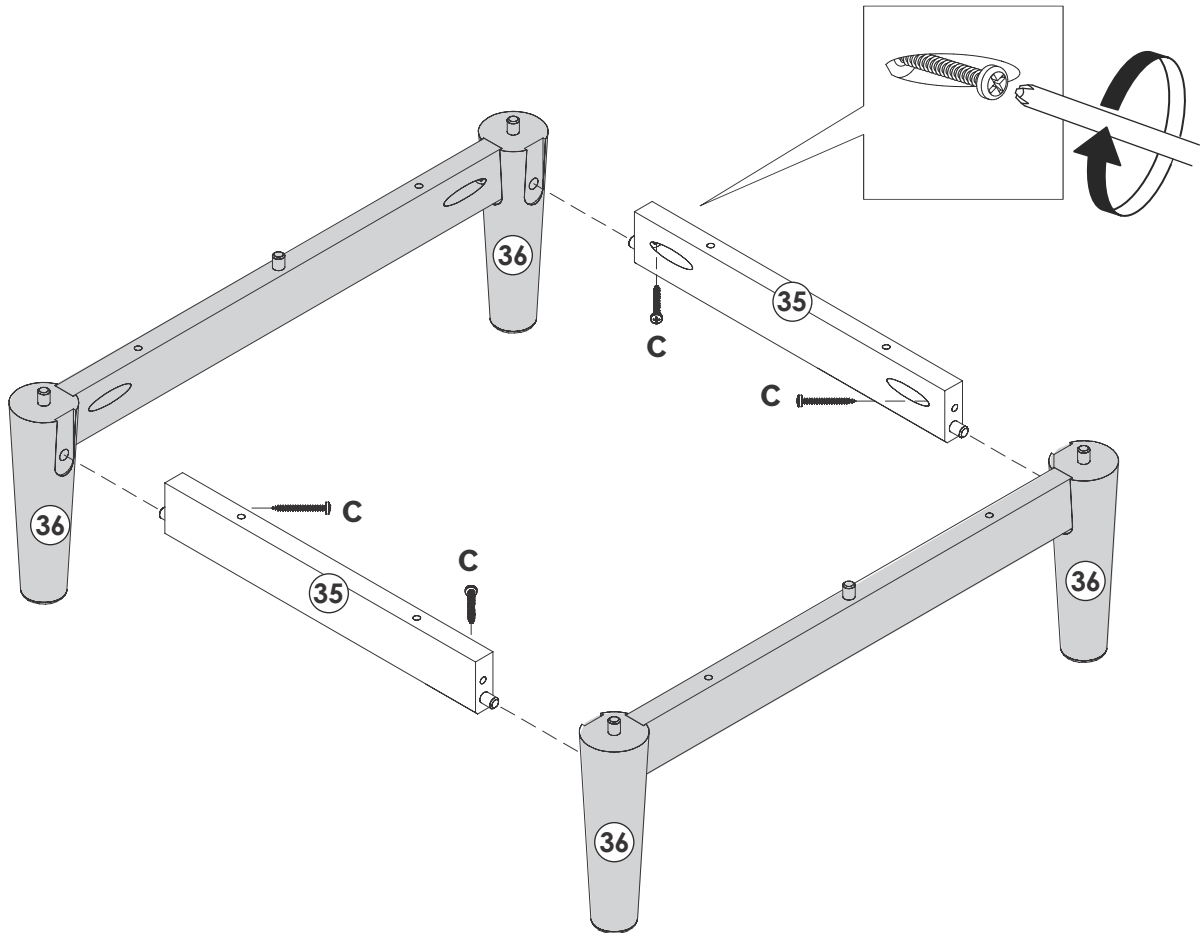
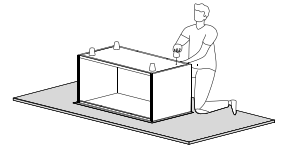

Once this step is completed, your product should look like this.

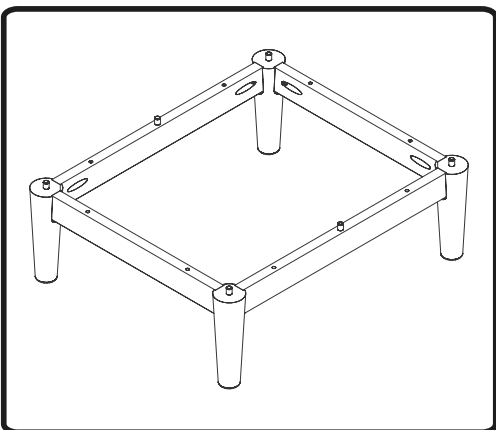

# Step 11

Join Bottom front rail (34) and Foot (36) to Bottom panel (04).  
Secure Bottom front rail (34) and Bottom side rail (35) to  
Bottom panel (04) using Screw (C) and Phillips head screwdriver.

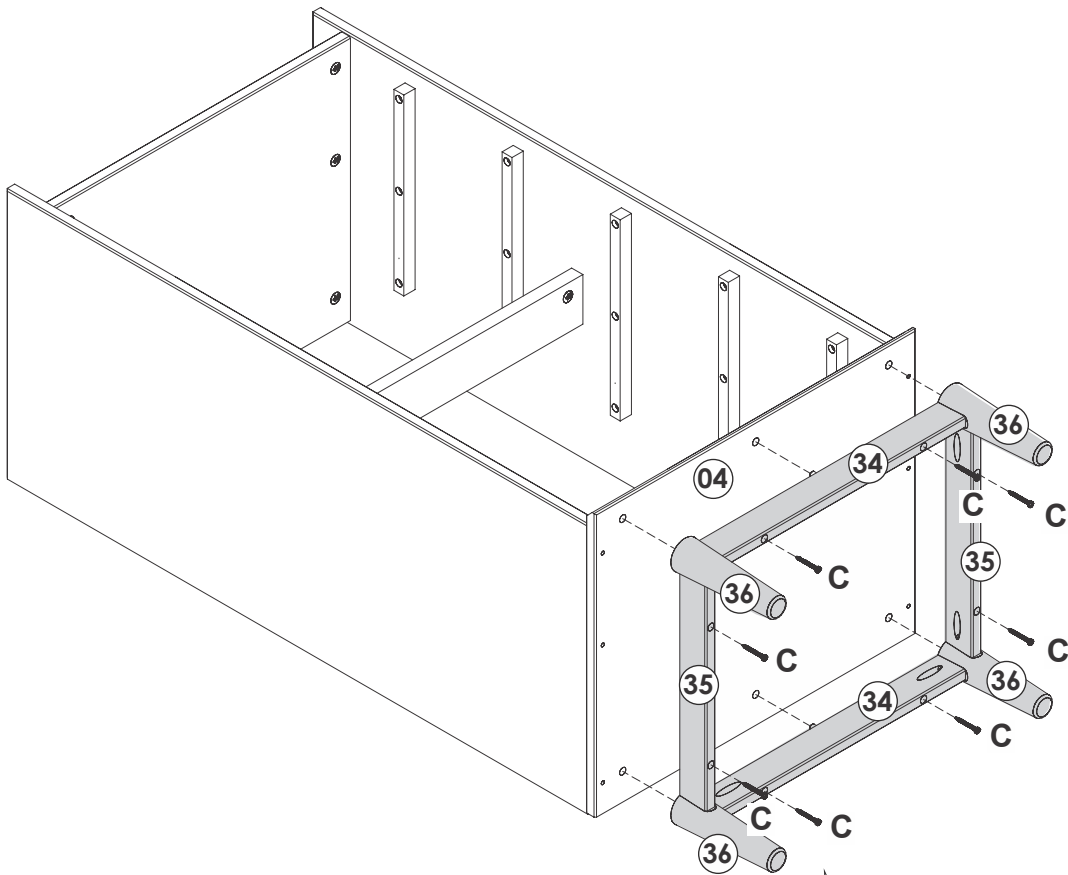
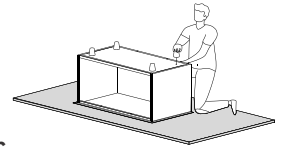

Once this step is completed, your product  
should look like this.

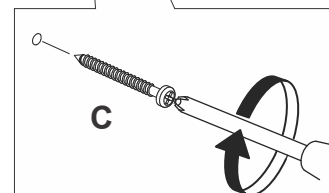
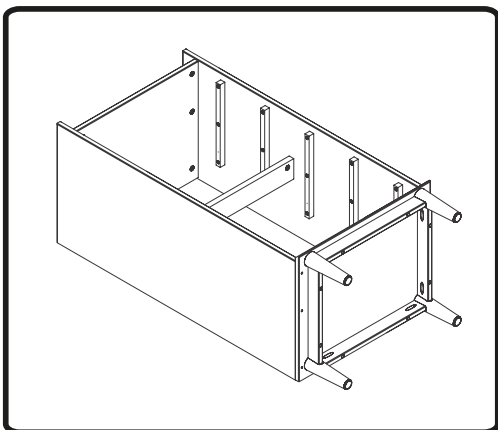

# Step 12

Insert Cam lock (F) in the hole on Top rail (15) and attach with Phillips head screwdriver.

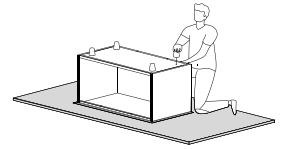

Rotate 90°

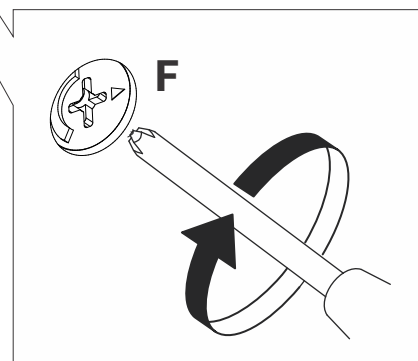
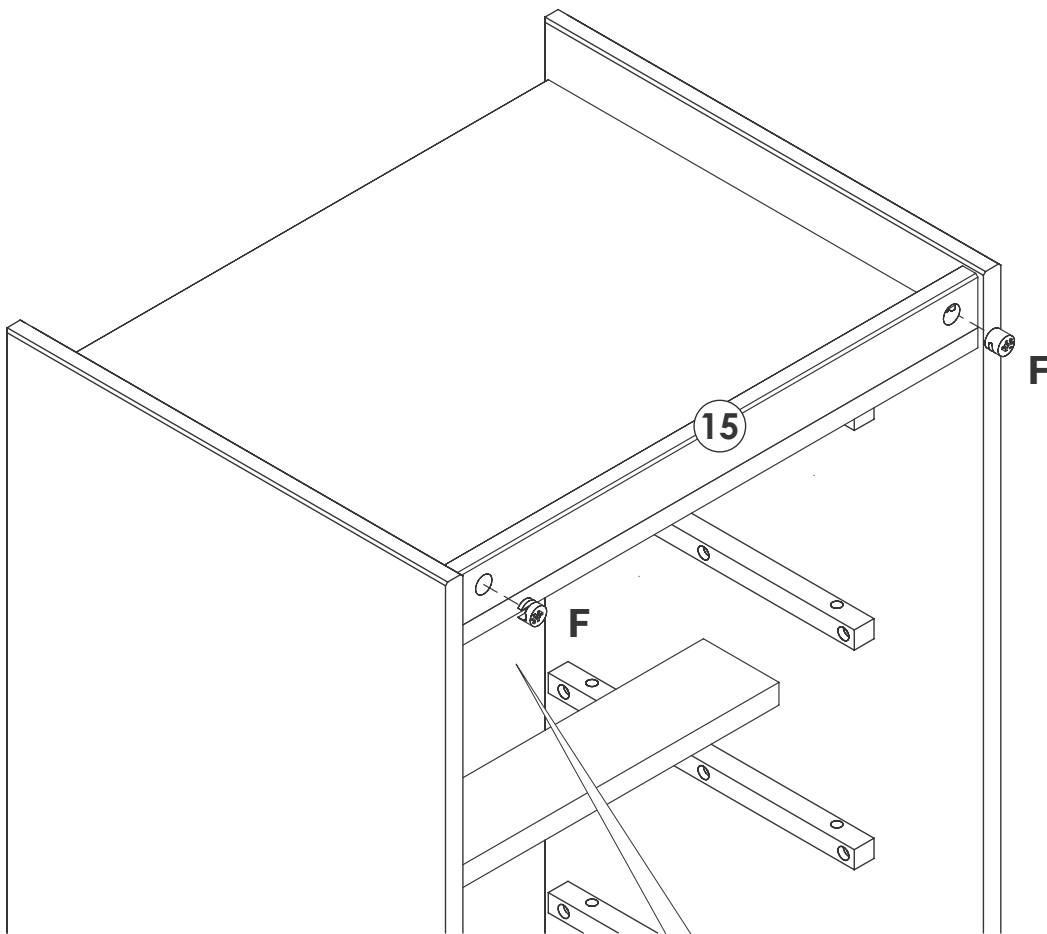
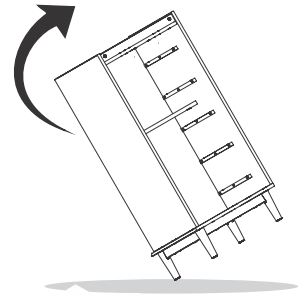



# Step 13

Fit Back panel (16) into Top panel (01), Bottom panel (04), Left side panel (42) and Right side panel (43). Secure Back panel (16) to Top panel (01) and Bottom panel (04) using screw (H) and Phillips head screwdriver.

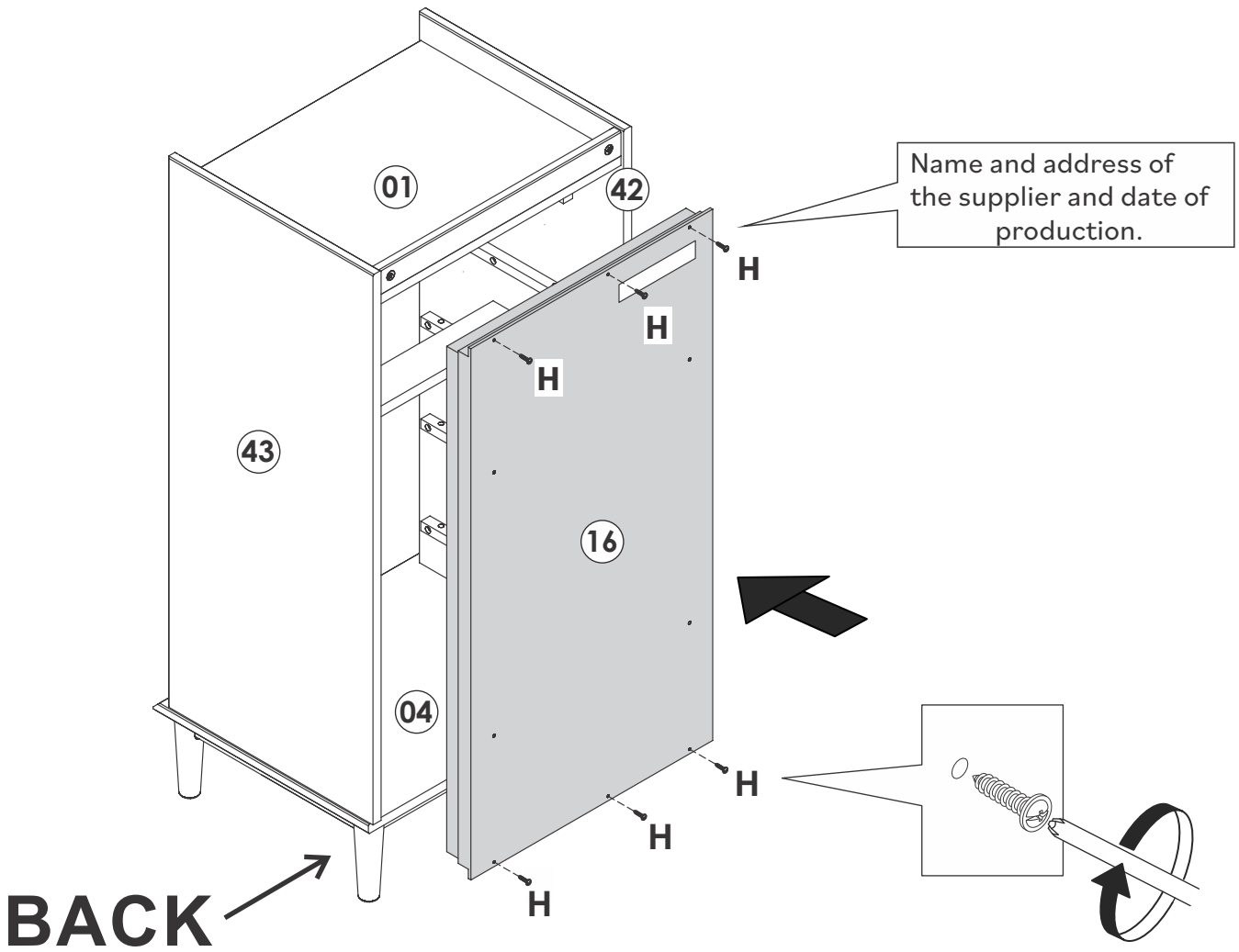
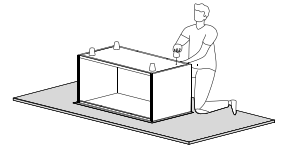

Once this step is completed, your product should look like this.

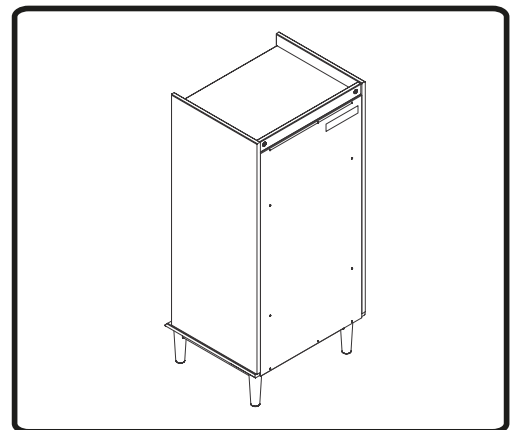

# Step 14

Insert Wooden dowel (A) into the front hole in Wood slider (17).

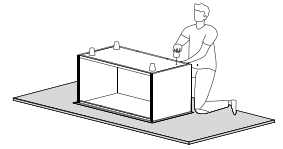

Rotate 90°

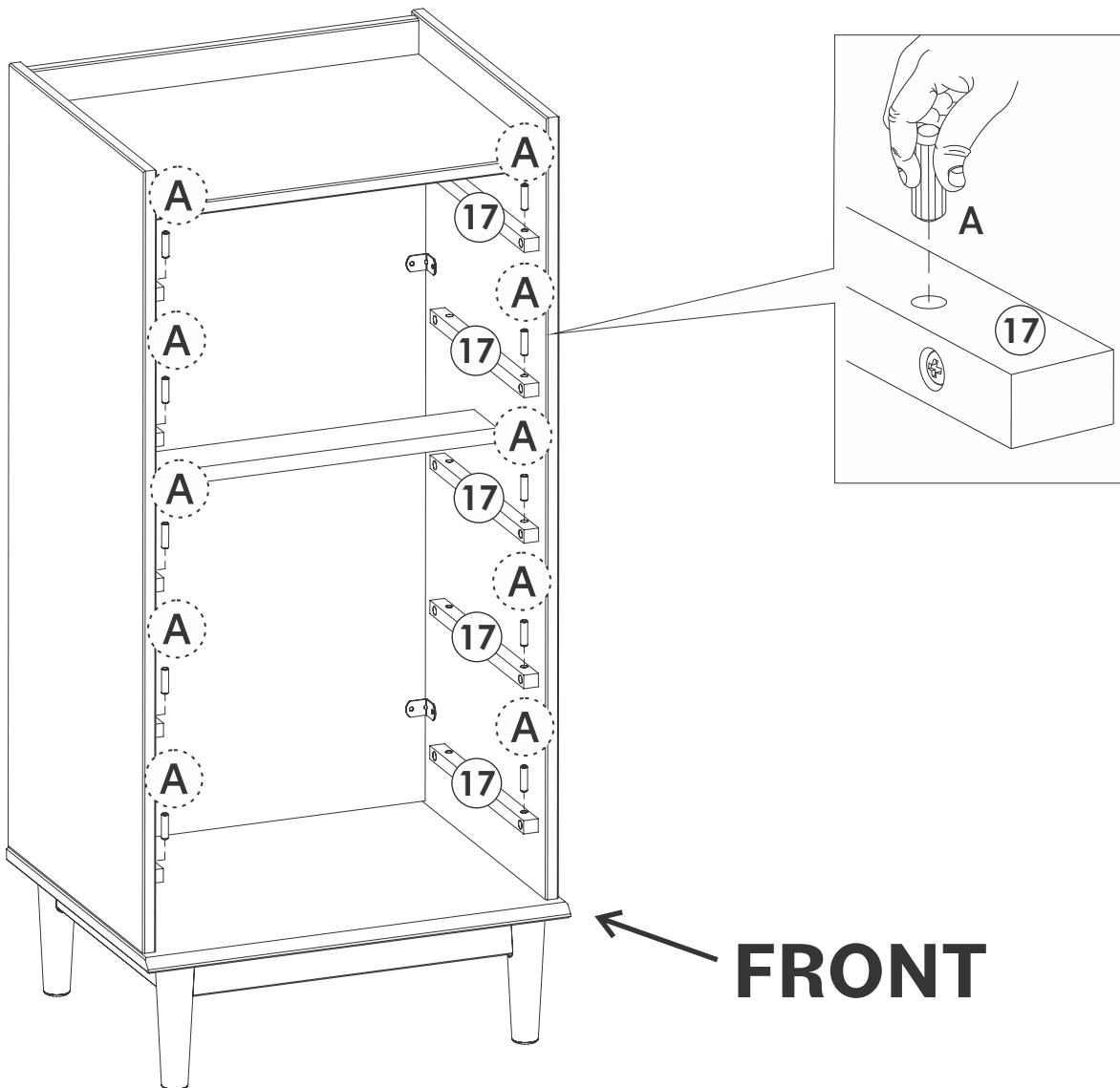
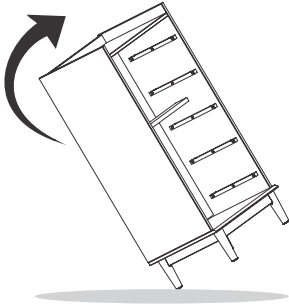

# Step 15

Attach Left drawer side (05), Right drawer side (06) and Right drawer side with warning (07) to Drawer front (08) using Cam locks (F).

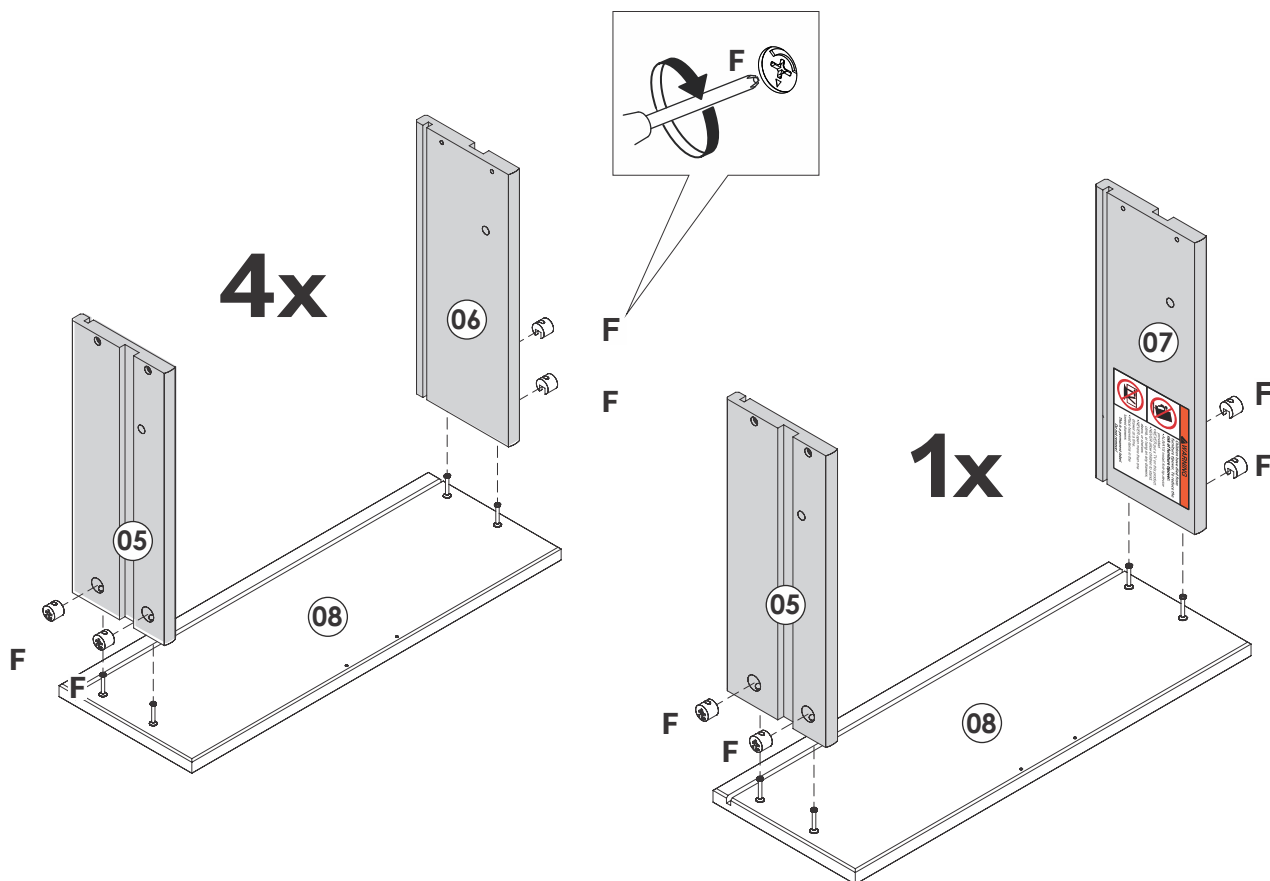
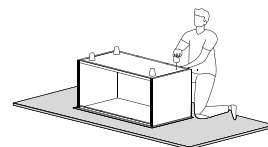

Once this step is completed, your product should look like this.

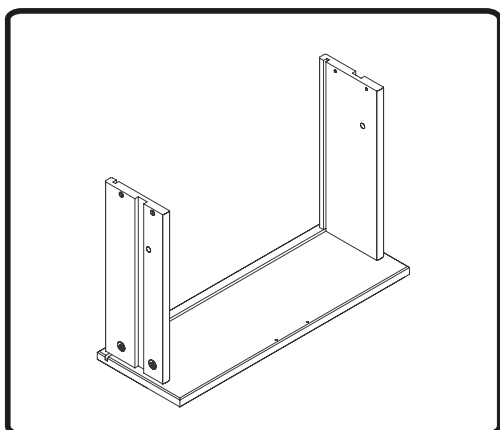

# Step 16

Slide Drawer bottom (48) into grooves on Left drawer side (05), Right drawer side (06) and Right drawer side with warning (07), and fit in Drawer front. Secure Drawer back (10) with Screw (E) and Phillips head screwdriver.

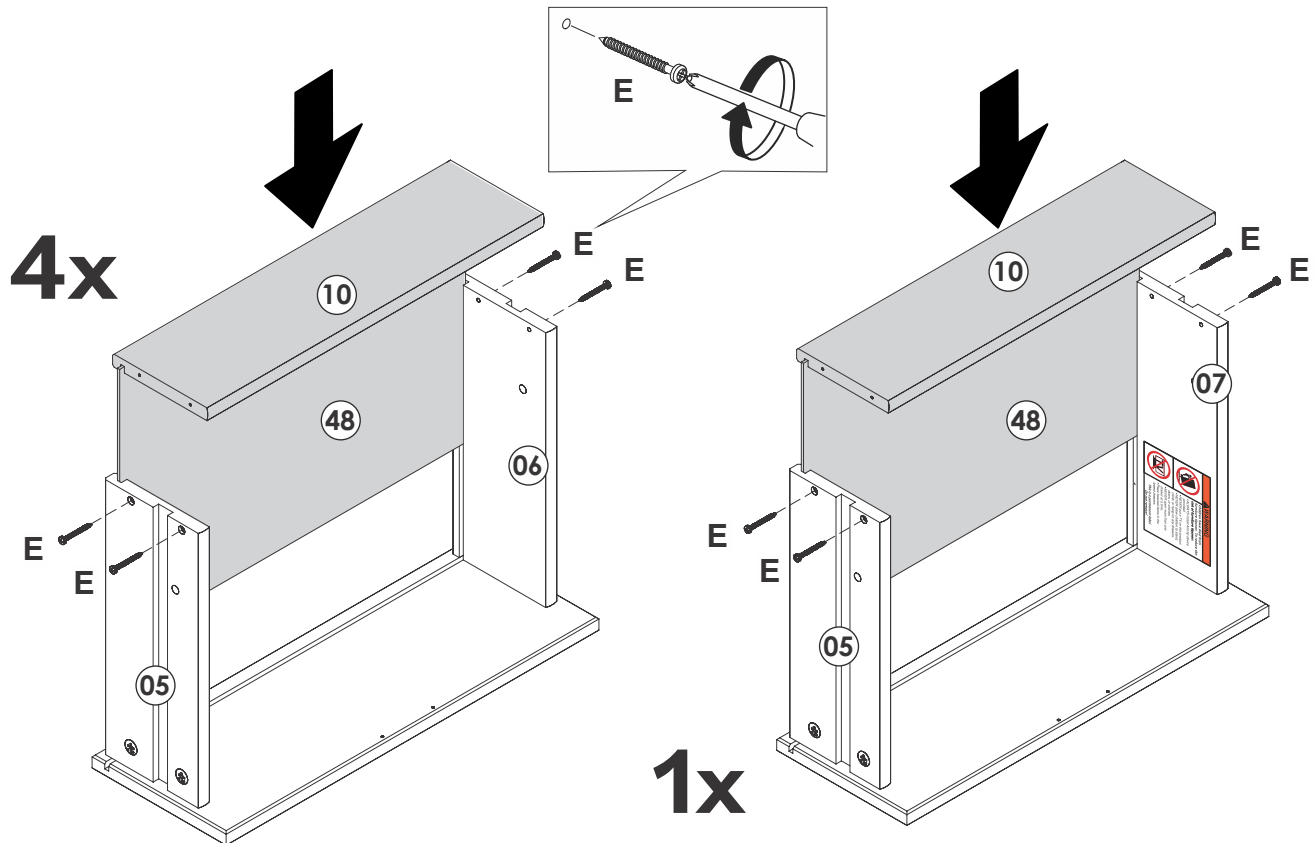
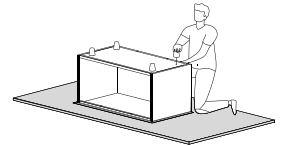

Once this step is completed, your product should look like this.

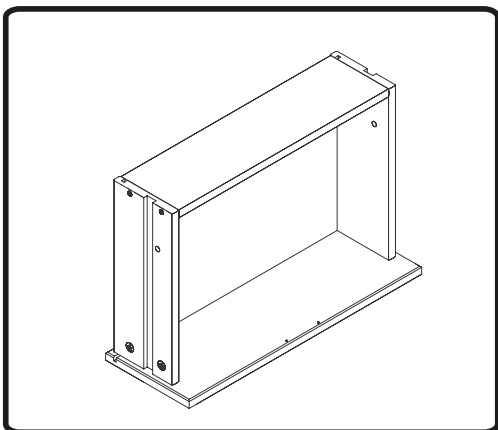

# Step 17

Attach Handle (N) with Screw (D) and a Phillips head screwdriver.

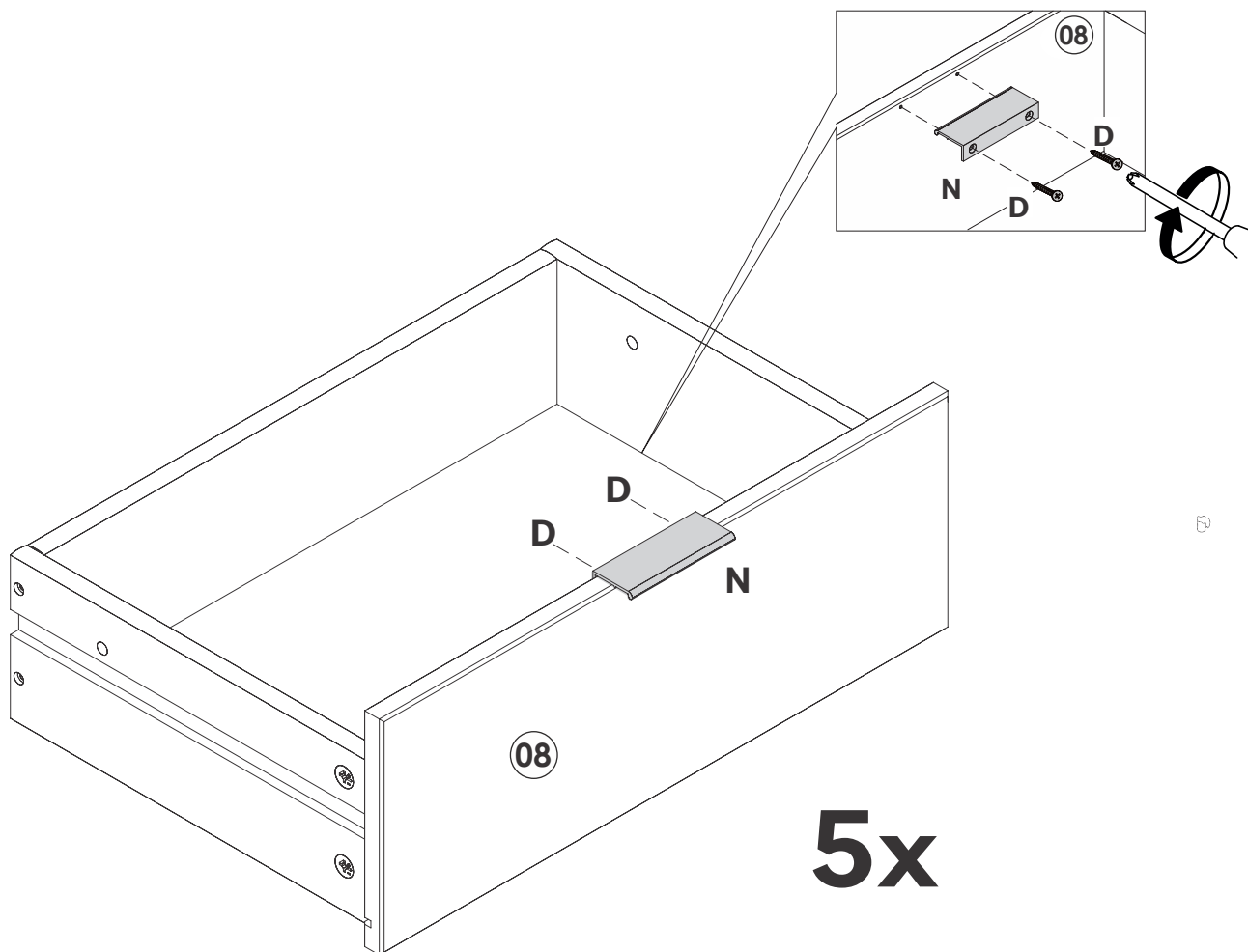
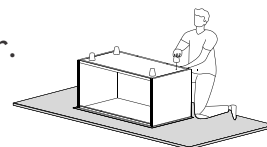

Once this step is completed, your product should look like this.

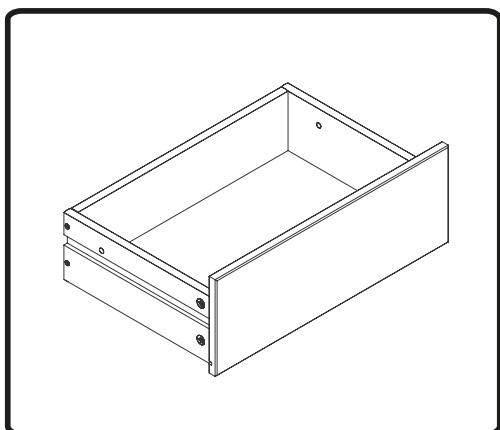

# Step 18

One at a time, place each drawer inside the unit, ensuring that you have passed the wooden dowel that is on the drawer slide. Then, insert Wooden Dowels (I) into place inside the drawers. Please note: Do not push the dowel all the way in. It will slightly stick out into the drawer so you are able to remove it if needed.

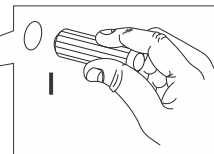
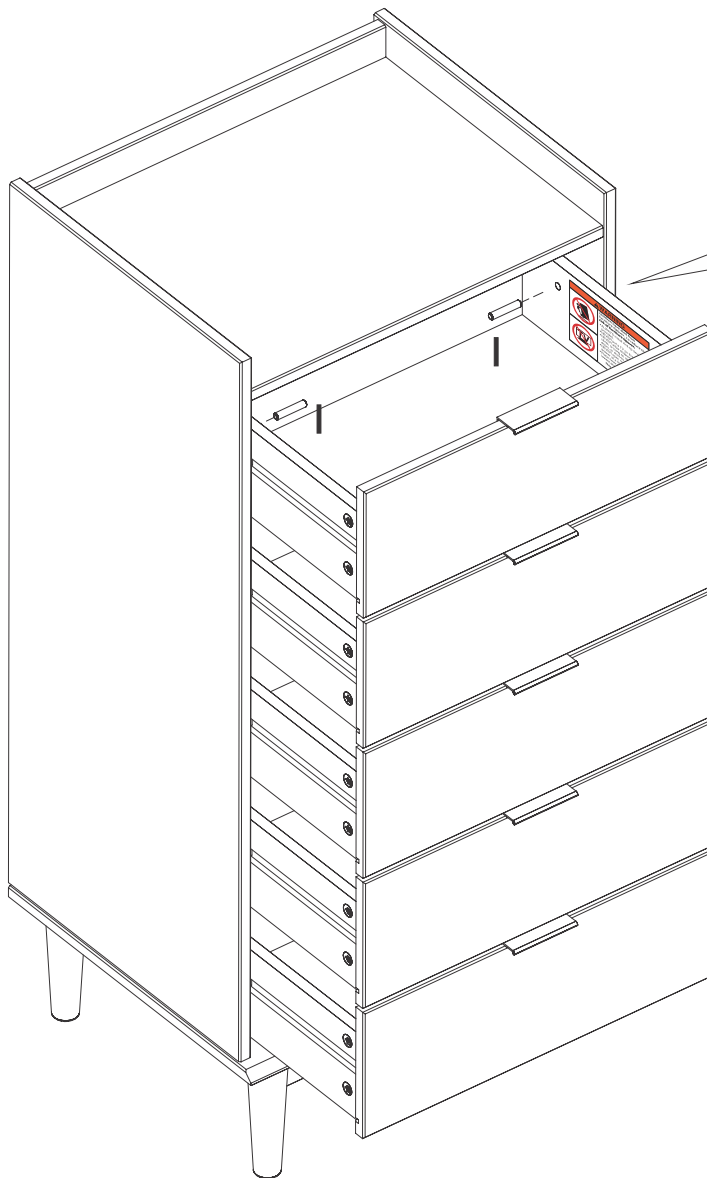
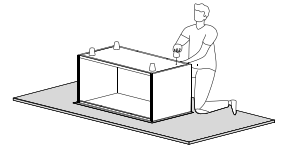

**WARNING**

Children have died from furniture tipover. To reduce the risk of furniture tipover:

- ALWAYS install Anti-tip device provided.
- NEVER put a TV on this product.
- NEVER allow children to stand, climb, or hang on any drawers, doors, or shelves.
- NEVER open more than one drawer at a time.
- Place heaviest items in the lowest drawers.

*This is a permanent label. Do not remove!*



The assembled drawer with this warning must be placed on top of the unit.

# Step 19

## WARNING

Serious or fatal injuries can occur from furniture tipping over. To prevent the furniture from tipping over we recommend that it is permanently fixed to the wall. Wall anchor and hardware are included with this product. Please make sure hardware is suitable for your walls before installing, as different wall materials may require different types of anchors.

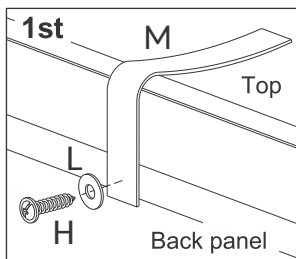

### ! 1st

Attach Anchor (M) with Screw (H) and Washer (L), in the frame of top panel unit using Phillips head screwdriver.

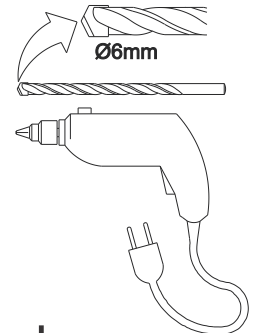

### ! 2nd

Using a drilling machine, make one hole in the wall, insert Bush (K) in the hole. Secure Anchor (M) with Screw (E) and Washer (L) in the wall using a Phillips head screwdriver.

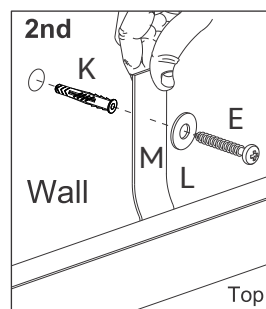
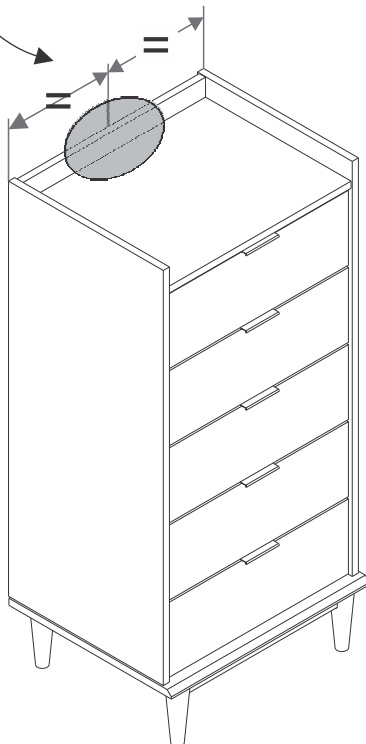

Wall



Name and address information for the manufacturer responsible for the anti-tip hardware and date of production can be found on the label on the back of the furniture.

You did it! Enjoy your new chest!

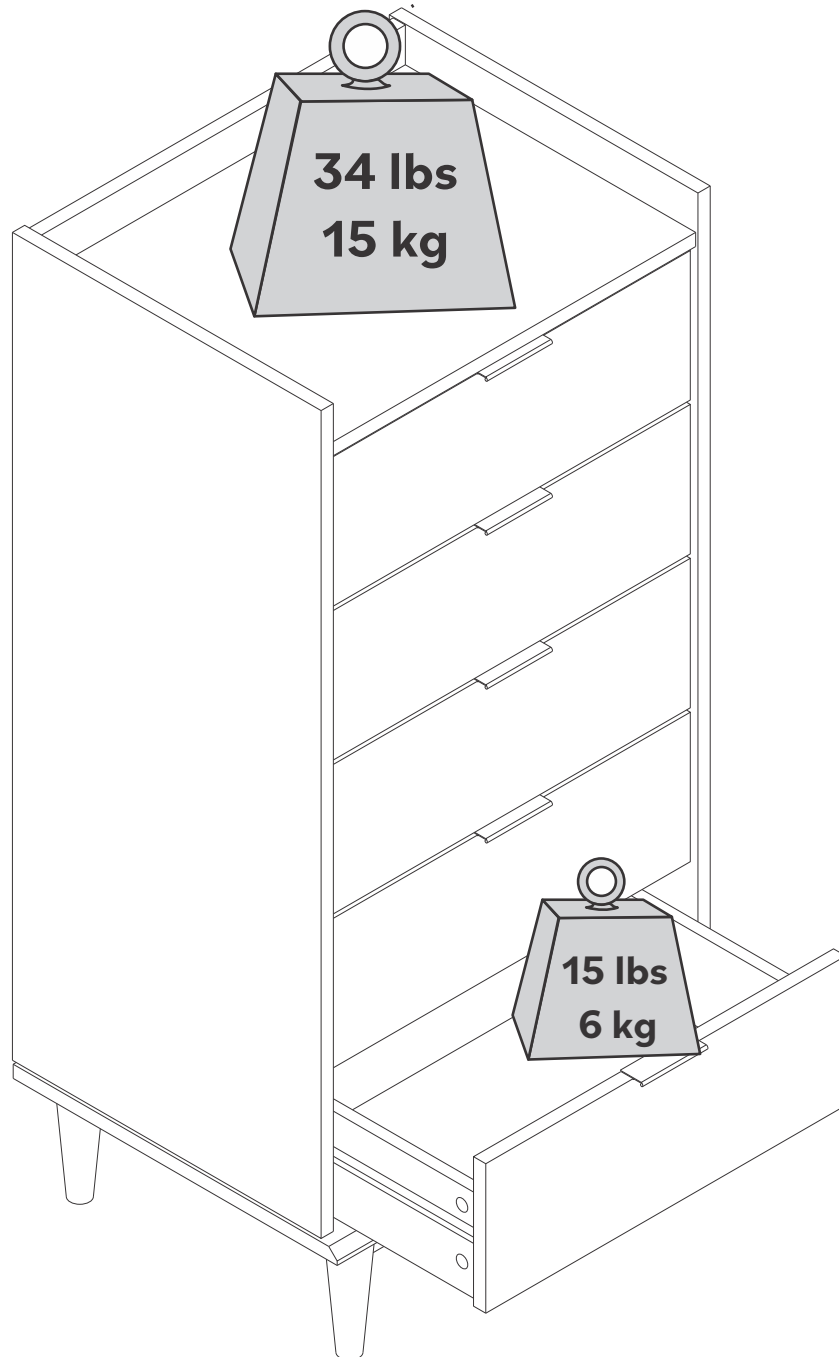

Congratulations on your new piece of furniture! We would love to hear about it and see it. Please leave us a review or post a picture with #mywalkeredisonhome



# Assembling furniture can be tricky sometimes.

Our customer service team, located in Utah, is here for product information, help assembling a product, or for any other customer support issue

Call us at **801-433-3008**

Email us at **[service@walkeredison.com](mailto:service@walkeredison.com)**

Visit our Customer Service website at **[walkeredison.com/pages/customer-service](http://walkeredison.com/pages/customer-service)**

We are available to help Monday-Thursday 8am-5pm, Friday 8am-3pm MST

For details on Assembly Videos, Assembly Instructions, Replacement Parts, and Customer service,

**SCAN HERE**

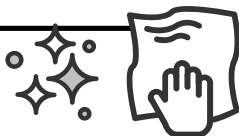

For cleaning, never use abrasives, use a soft cloth and water with neutral soap to clean the furniture.

# WALKER EDISON™

Lee Commode Haute  
Lee Cómoda Alta  
SKU: LEEB3B-T

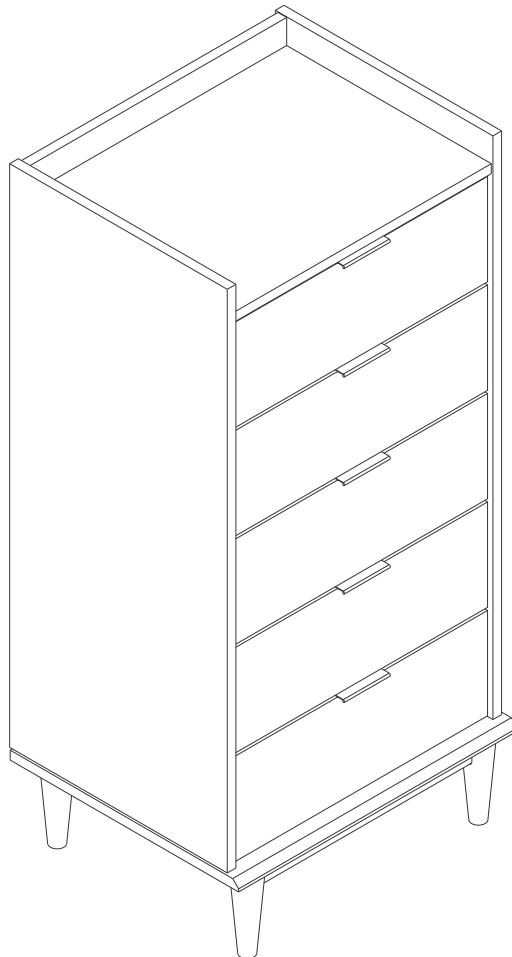

## *Pour usage résidentiel seulement*

Visite notre site Web pour obtenir les instructions les plus récentes, des conseils d'assemblage, signaler des dommages ou commander des pièces. [www.walkeredison.com](http://www.walkeredison.com)

## *Sólo para uso residencial*

Visite nuestro sitio web para consultar las últimas instrucciones, consejos de montaje, notificar daños o solicitar piezas. [www.walkeredison.com](http://www.walkeredison.com)

# WE Il est temps de commencer / Hora de empezar

Prépare un lieu de travail propre et souple pour éviter tout dommage lors de l'assemblage. Tu peux utiliser la boîte et les protections internes comme base. Vérifie également que tu disposes de toutes les pièces et parties avant de te lancer dans l'assemblage.

Prepare un lugar de trabajo limpio y blando para evitar daños durante el montaje. Puede utilizar la caja y las protecciones internas como base. Comprueba también que tiene todas las piezas y partes antes de sumergirse en el montaje.

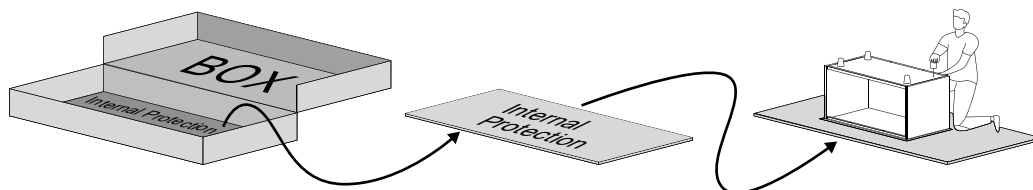

**Temps de montage  
estimé**

**Tiempo estimado  
de montaje**

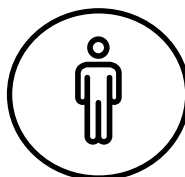

1 Person Build

**Vous pouvez le faire seul.**

Mais vous pouvez en faire un travail d'équipe !  
Demandez à un ami de vous aider à l'assembler plus rapidement et plus facilement.

**Puedes hacerlo solo**

Pero también puedes hacerlo en equipo.  
Llévate a un amigo para que el montaje sea más rápido y sencillo.

## Outils nécessaires

Munis-toi d'un tournevis cruciforme pour réaliser cet assemblage

## Herramientas requeridas

Tome un destornillador Phillips para conquistar este conjunto.

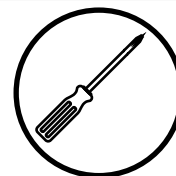

## Utilise les outils électriques avec précaution

Ce meuble est réalisé en Bois Massif et Bois Composite, des matériaux souples. Si tu choisis d'utiliser des outils électriques, règle-les sur le mode le plus lent. Fais attention à toi ! Les outils électriques peuvent provoquer des fissures ou endommager les meubles, mais aussi les autres composants s'ils sont mal utilisés. Les dommages causés par un outil électrique ne sont pas couverts par la garantie Walker Edison.

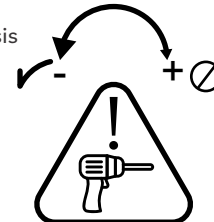

## Utilice las herramientas eléctricas con cuidado

Este mueble está fabricado con madera maciza y madera compuesta, materiales blandos. Si decide utilizar herramientas eléctricas, ajústelas al ajuste más lento. Tenga cuidado. Las herramientas eléctricas pueden causar grietas o daños en el mueble, pero también en los herrajes si se utilizan mal. Los daños causados por una herramienta eléctrica no están cubiertos por la garantía de Walker Edison.

## Attention avec la glissière

Tes meubles possèdent des glissières en bois très résistantes. De temps en temps, nous recommandons d'appliquer de la paraffine ou de la cire de bougie standard pour améliorer la glisse des curseurs.

## Cuidado con las guías

Tus muebles cuentan con guías de madera de alta durabilidad. De vez en cuando, recomendamos la aplicación de parafina o cera estándar para mejorar el deslizamiento de los deslizadores.



**Scannez pour obtenir des conseils d'assemblage et de l'aide !**  
**Escanee para obtener consejos de montaje y ayuda!**

# WE Liste de pièces / Lista de piezas

Nombre de pièces Número de pieza	Description Descripción	Quantité Cantidad
01	Panneau Supérieur Panel Superior	01
04	Panneau Inférieur Panel Inferior	01
05	Côté Gauche du Tiroir Lado Izquierdo del Cajón	05
06	Côté Droit du Tiroir Lado Derecho del Cajón	04
07	Côté Droit du Tiroir Avertissement Lado Derecho del Cajón Advertencia	01
08	Façade du Tiroir Frènte del Cajón	05
10	Arrière du Tiroir Trasero del Cajón	05
15	Barre Supérieur Travesaño Superior	01
16	Panneau Arrière Panel Trasero	01

Nombre de pièces Número de pieza	Description Descripción	Quantité Cantidad
17	Glissière Corredera	10
34	Barre Avant Inférieur Travesaño Delantero Inferior	02
35	Barre latéral inférieur Travesaño Lateral Inferior	02
36	Pied Pies	04
42	Panneau Gauche Panel Izquierdo	01
43	Panneau Droit Panel Izquierdo	01
44	Barre Central Travesaño Central	01
48	Fond du Tiroir Inferior del Cajón	05

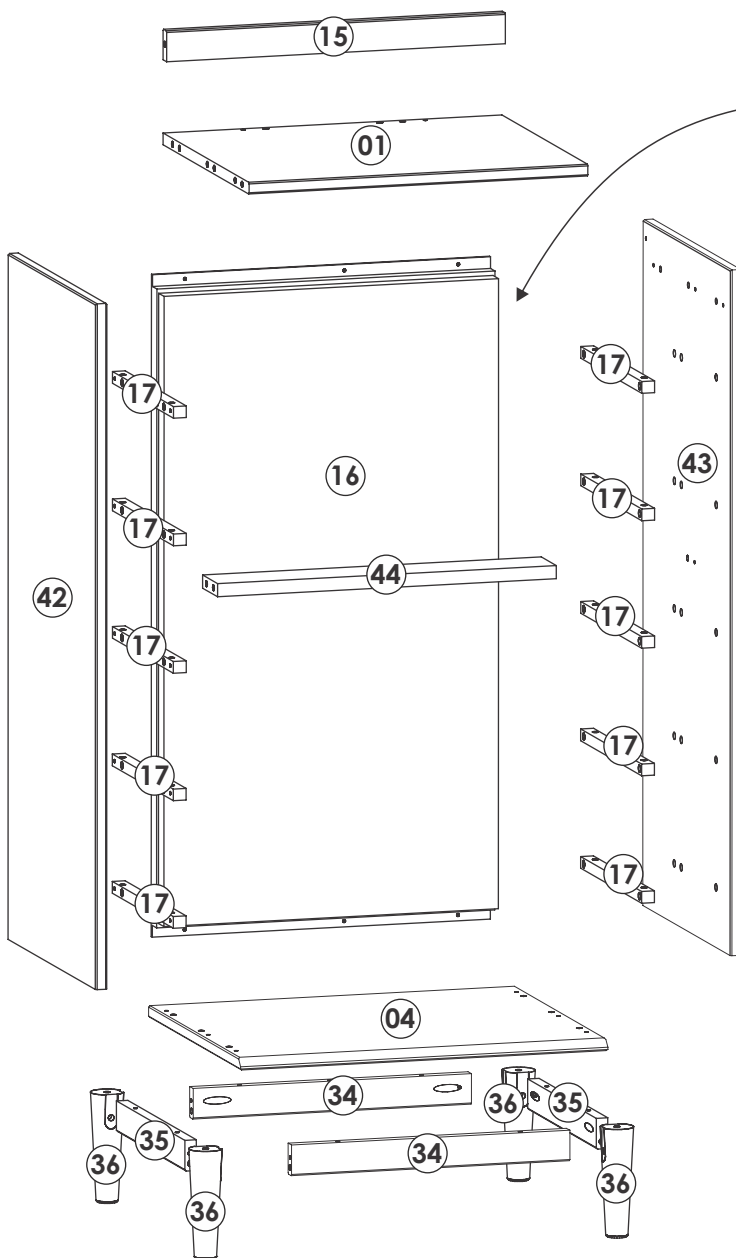

**WALKER EDISON**  
Distribution and responsible for the anti-tip hardware:  
Walker Edison Furniture Company  
1553 W 9000 S, West Jordan,  
UT 84088 United States

For details on Assembly Videos, Assembly Instructions,  
Replacement Parts and Customer Service, SCAN HERE

**LEE**

Model: XXXXXXXXFF  
LOT: AAYYWW-XXX  
Date: MM/20YY  
Rev: MM/20YY-VX

CANFER compliant / conforme au CANFER  
TSCA Title VI compliant / conforme au titre VI de la TSCA  
TSCA Title VI certified / certifié conformément au titre VI de la TSCA  
California 93120 Compliant for Formaldehyde  
Conforme à la norme Californie 93120 pour le formaldéhyde

**WARNING**

Children have died from furniture tipover. To reduce the risk of furniture tipover:

- ALWAYS install Anti-tip device provided.
- NEVER put a TV on this product.
- NEVER allow children to stand, climb, or hang on any drawers, doors, or shelves.
- NEVER open more than one drawer at a time.
- Place heaviest items in the lowest drawers.

*This is a permanent label. Do not remove!*







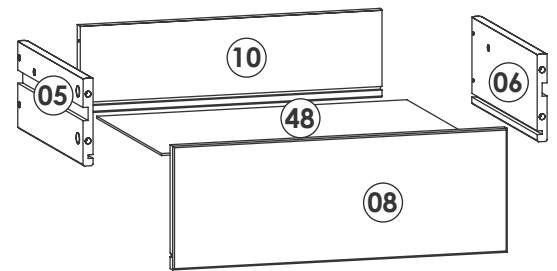



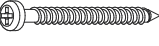

A gaveta lateral com a etiqueta WARNING LABEL, deve ser montada na gaveta mais alta.

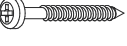
A gaveta lateral com a etiqueta WARNING LABEL, deve ser montada na gaveta mais alta.

**5x**

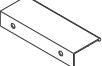

## WE Liste de composants / Lista de hardware

	Partie Parte	Taille Tamaño	Nom Nombre	Quantité Cantidad
A		8x30mm	Cheville Espiga	41
B		10x20mm	Cheville Espiga	30
C		4,0x40mm	Vis Tornillo	22
D		3,0x12mm	Vis Tornillo	10
E		3,5x30mm	Vis Tornillo	23
F		15x12mm	Boitier Traba	30
G		5x24mm	Goujon Conector	30
H		3,5x20mm	Vis Tornillo	07
I		8x40mm	Cheville Espiga	10
J		4,0x25mm	Vis Tornillo	30
K		6x35mm	Douille Casquillo	01
L			Arandela Rondele	02
M			Rubán Cinta	01
N			Poignée Manija	05

Les quantités de composants indiquées ci-dessus sont nécessaires pour un assemblage correctt.  
Des pièces supplémentaires peuvent être incluses.

Las cantidades de tornillería indicadas anteriormente son necesarias para un montaje correcto.  
Se pueden incluir piezas de ferretería adicionales.

# Étape / Paso 1

(FR)

Commençons! Insérez les Chevilles en bois (A) dans le Panneau supérieur (01), Barre supérieur (15), Rail avant inférieur (34), Barre latéral inférieur (35), Pied (36), Panneau latéral gauche (42) et Panneau latéral droit (43).

(ES)

¡Comencemos! Inserte las Clavijas de madera (A) en el Panel superior (01), Travesaño superior (15), Travesaño frontal inferior (34), Travesaño lateral inferior (35), Pie (36), Panel lateral izquierdo (42) y Panel lateral derecho (43).

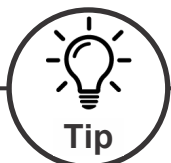
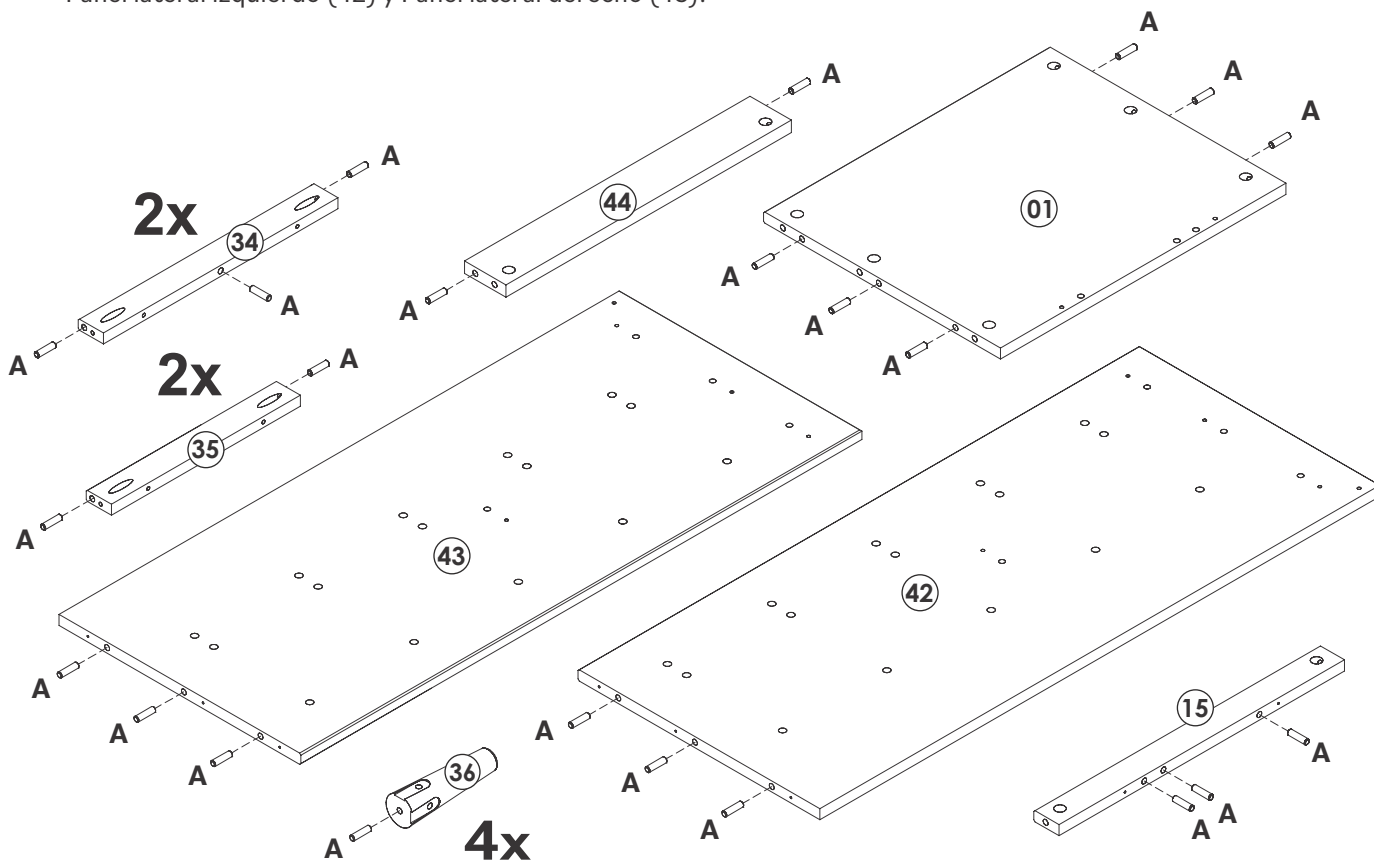
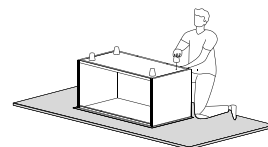

Les chevilles sont essentielles lors de l'assemblage de meubles pour créer des connexions solides et précises. Elles garantissent l'intégrité structurelle, empêchent les déplacements et simplifient l'alignement, ce qui permet d'obtenir des meubles plus résistants et plus durables. Suis ces étapes:

Las espigas son esenciales en el montaje de muebles para crear uniones fuertes y precisas. Garantizan la integridad estructural, evitan el desplazamiento y simplifican la alineación, lo que se traduce en muebles más resistentes y duraderos. Sigue estos pasos:

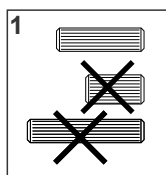

1: Sélectionne la taille de cheville appropriée en fonction de l'étape.  
1: Seleccione el tamaño de espiga adecuado según el paso.

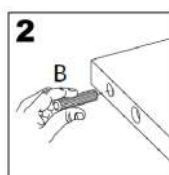

2: Insère dans le trou indiqué et appuie fermement pour assurer un positionnement correct.  
2: Insértela en el orificio indicado y presione firmemente para asegurar su correcta colocación.

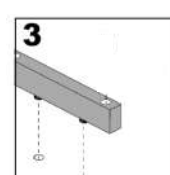
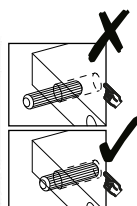

3: Aligne la cheville avec la pièce correspondante et enfonce-la jusqu'à ce qu'elle soit ferme.  
3: Alinee el pasador con la pieza correspondiente y presiónelo hasta que encaje

# Étape / Paso 2

(FR)

Insérez la Cheville en bois (B) Glissière (17).

(ES)

Inserte la Espiga de madera (B) en la Corredera (17).

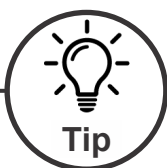
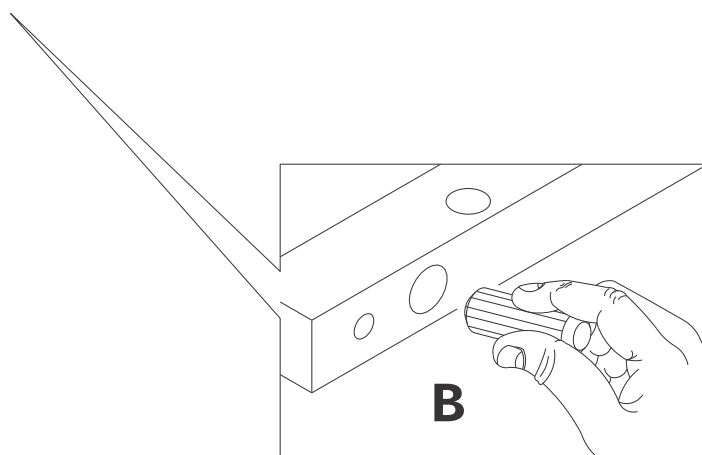
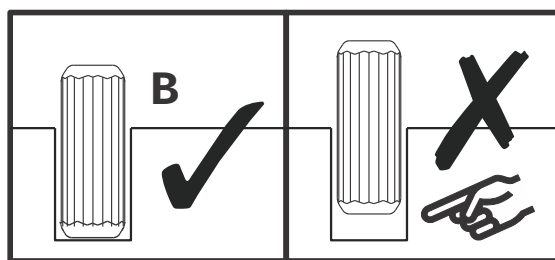
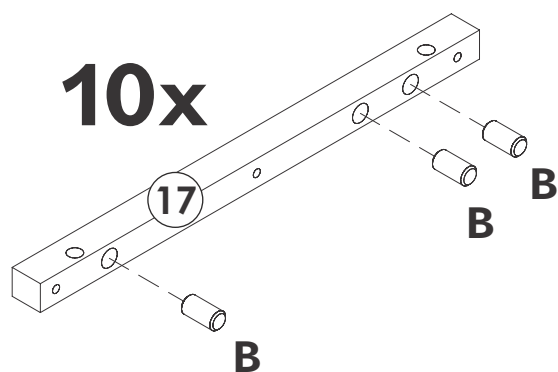

Pour que ton produit conserve son meilleur aspect et sans rayures, essaie de le monter sur une surface souple telle qu'un tapis ou une couverture. Cela permet d'éviter les rayures accidentelles et de garder tes meubles en bon état!

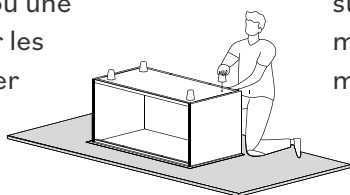

Para mantener su producto con el mejor aspecto y sin arañazos, pruebe a montarlo sobre una superficie blanda, como una alfombra o una manta. Así evitará arañazos accidentales y mantendrá sus muebles en perfecto estado.

# Étape / Paso 3

(FR)

Fixez le Goujon (G) dans les trous de la Façade du tiroir (08), Panneau latéral gauche (42) et Panneau latéral droit (43) avec un tournevis cruciforme.

(ES)

Coloque el Conector (G) en los orificios del Frente del cajón (08), Panel lateral izquierdo (42) y Panel lateral derecho (43) con un destornillador Phillips.

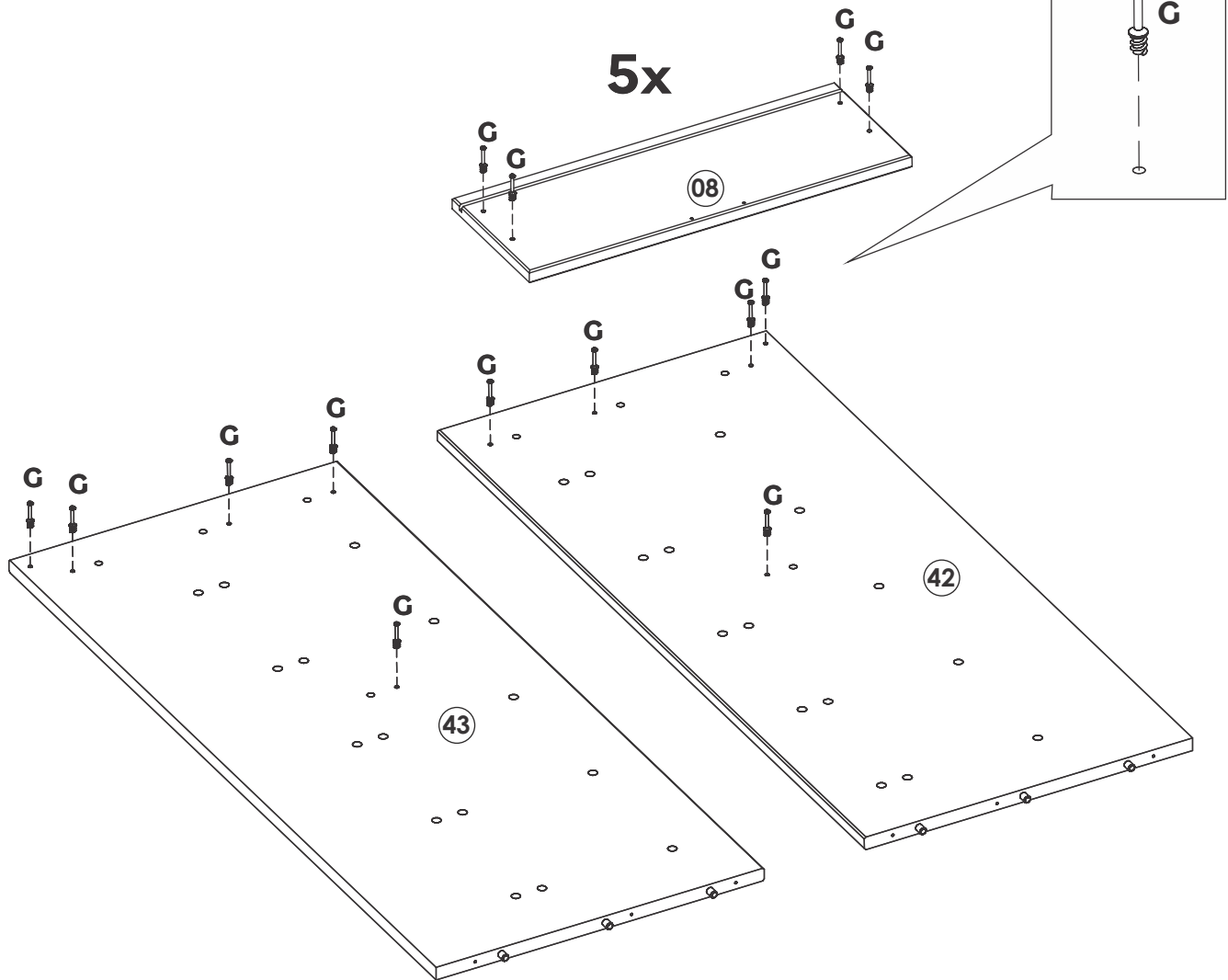
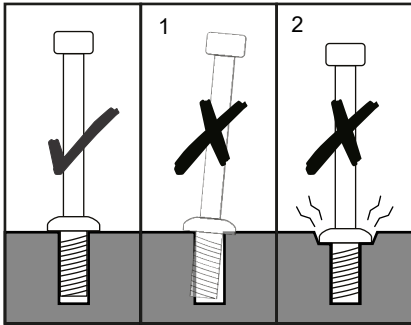
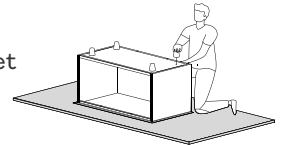



# Étape / Paso 4

(FR)

Fixez les Glissières (17) au Panneau latéral gauche (42) et au Panneau latéral droit (43) avec une Vis (J) et un tournevis cruciforme.

(ES)

Asegure las Correderas (17) al Panel lateral izquierdo (42) y Panel lateral derecho (43) con el Tornillo (J) y un destornillador Phillips.

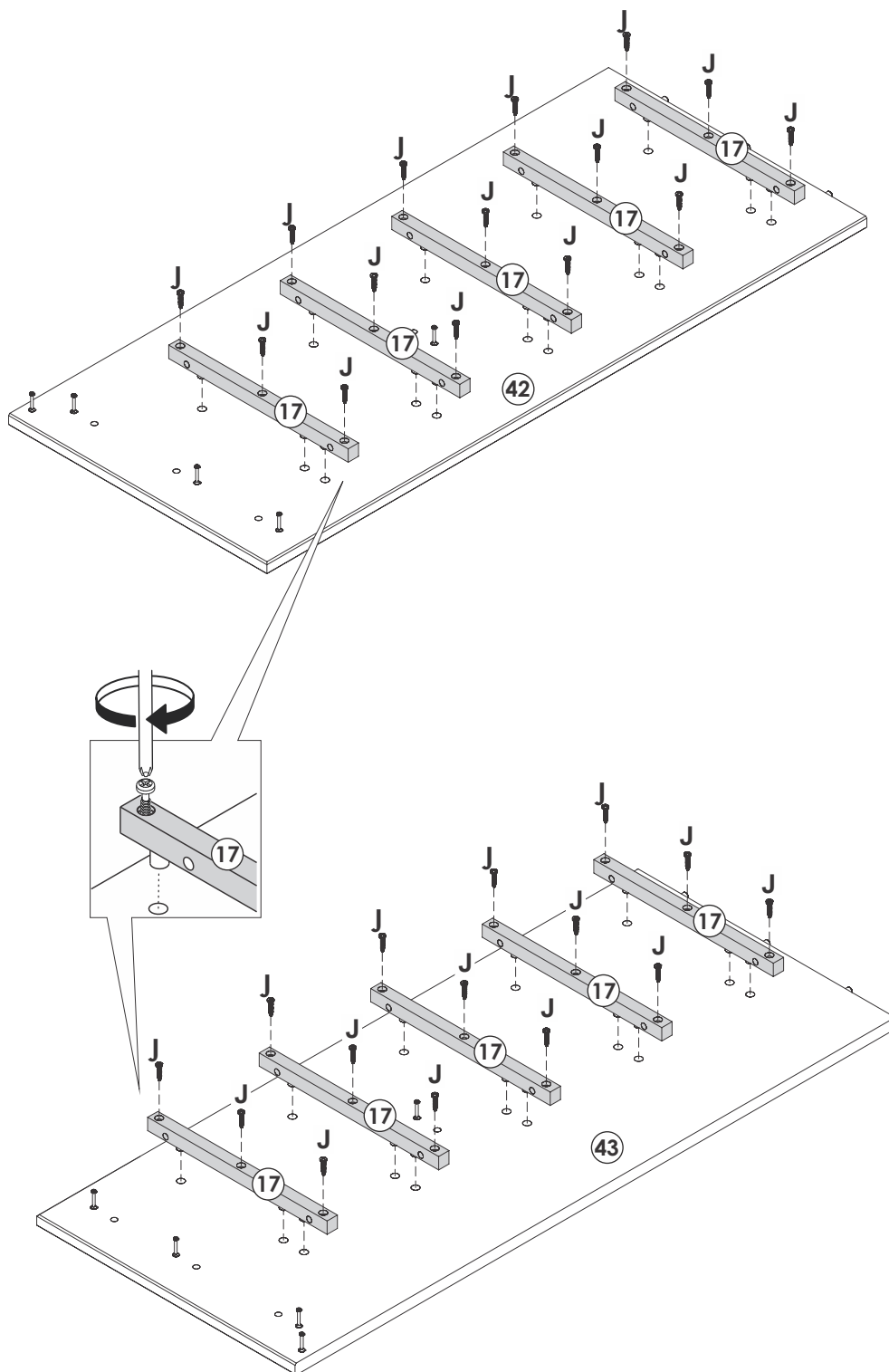
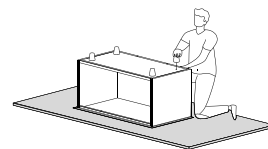

# Étape / Paso 5

(FR)

Fixez le Barre supérieur (15) au Panneau supérieur (01) à l'aide de la Vis (E) et d'un tournevis cruciforme.

(ES)

Asegure el Travesaño superior (15) al Panel superior (01) usando el Tornillo (E) y un destornillador Phillips.

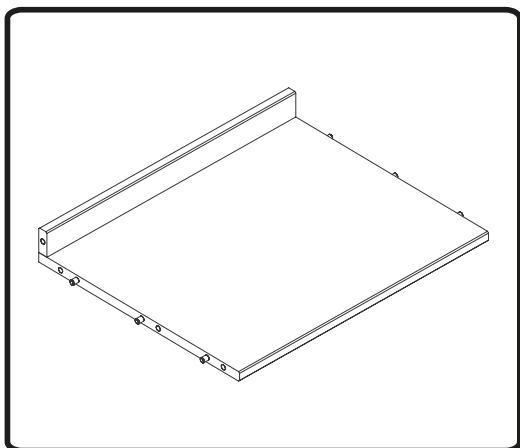
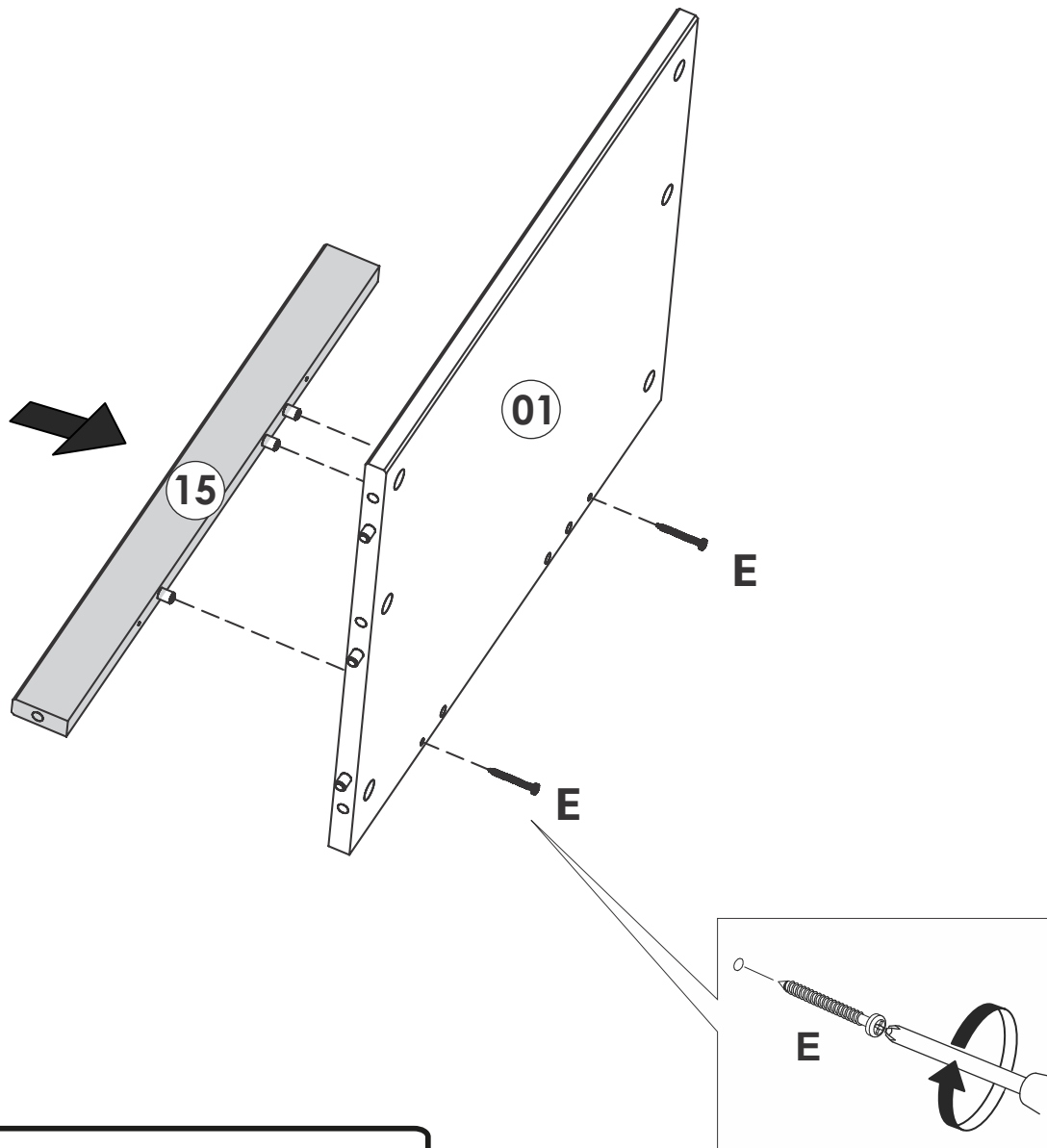
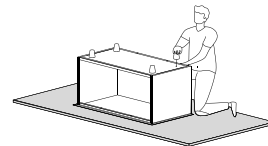

# Étape / Paso 6

(FR)

Assemblez le Panneau supérieur (01), Barre supérieur (15) et Barre central (44) au Panneau latéral droit (43). Insérez le Boitier (F) fixez-le à l'aide d'un tournevis cruciforme.

(ES)

Ensamble el Panel superior (01), Travesaño superior (15) y Travesaño central (44) al Panel lateral derecho (43). Inserte el Traba (F) y fíjelo con un destornillador Phillips.

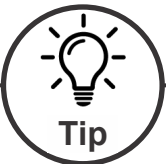
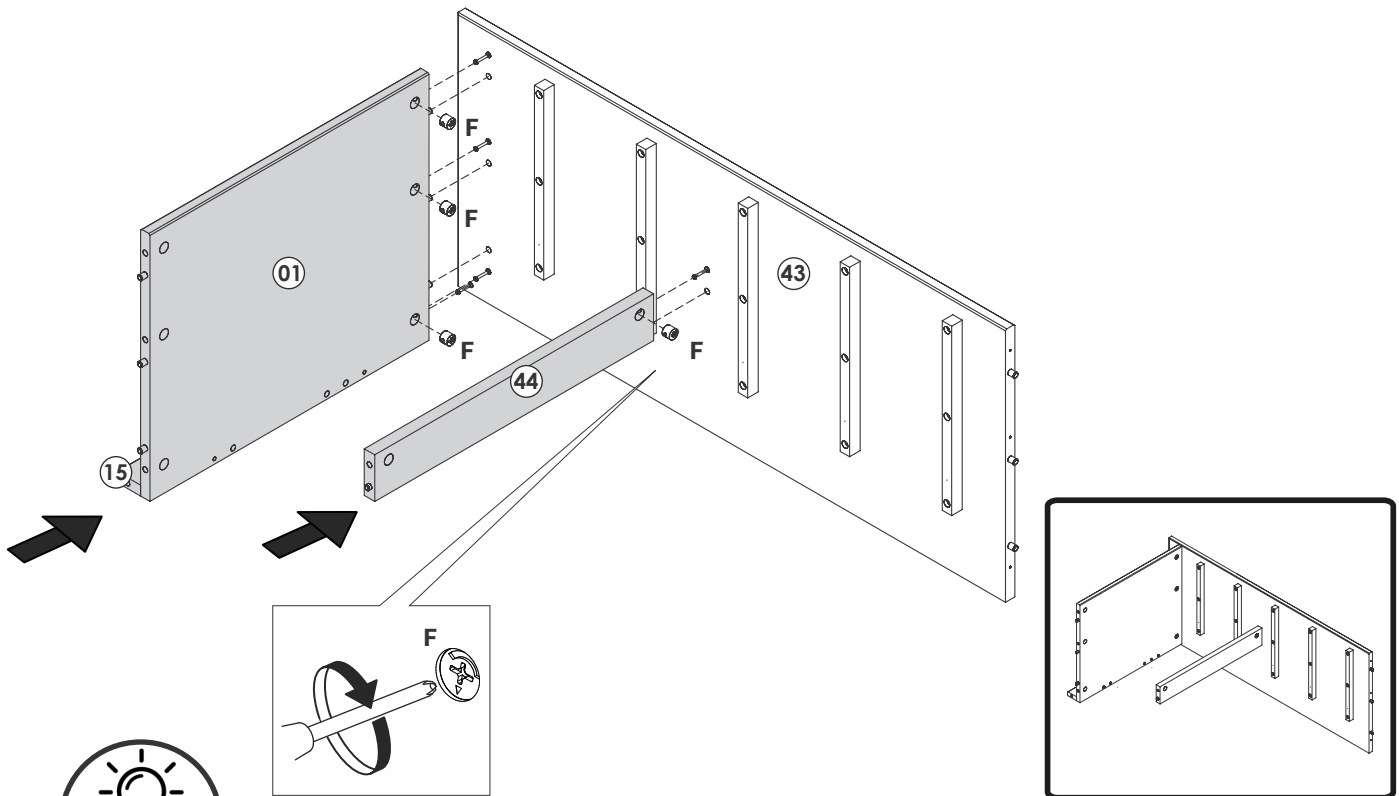
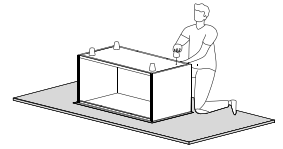

Tip

## Goujon

Goujon permet de joindre deux pièces en toute sécurité. Suis ces étapes simples.

## Conector

Los Conectores ayudan a unir de forma segura dos piezas. Sigue estas fáciles etapas.

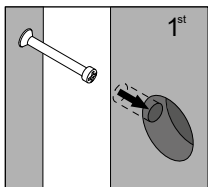

1<sup>st</sup>

1: Insère le Goujon dans les orifices du côté plat. Ne serre pas trop !  
1: Coloca el Conector en los orificios del lado plano. ¡No aprietes demasiado!

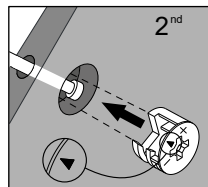

2<sup>nd</sup>

2: Joins les pièces en bois. Les Goujons entrent dans les orifices qui ont des trous sur les côtés, tu dois pouvoir voir les Goujons à travers ceux-ci. Après avoir installé les pièces, insère le Boitier dans les orifices latéraux  
2: Una las piezas de madera. Los Conectores entran en las piezas que tienen orificios en los lados, por lo que deberías poder ver los Conectores a través de ellos. Después de encajar las piezas, inserta el tambor de la traba en los orificios laterales.

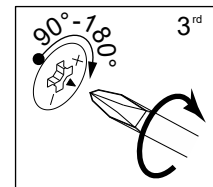

3<sup>rd</sup>

3: Sur la partie arrière du Boitier, il aura la forme d'un « C ». Insère le Boitier de manière à ce que l'ouverture « C » s'emboîte à le Goujon. Serre-la avec le tournevis.  
3: La parte posterior de la Traba tendrá la forma de "C". Inserta la Traba de modo que la abertura de la "C" encaje en el Conector. Apriétalo con un destornillador.

# Étape / Paso 7

(FR)

Assemblez le Panneau latéral gauche (42) au Panneau supérieur (01), Barre supérieur (15) et Barre central (44). Insérez le Boitier (F) et fixez-le à l'aide d'un tournevis cruciforme.

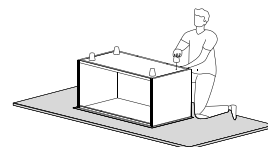

(ES)

Una el Panel lateral izquierdo (42) al Panel superior (01), Travesaño superior (15) y Travesaño central (44). Inserte la Traba (F) y fijela con un destornillador Phillips.

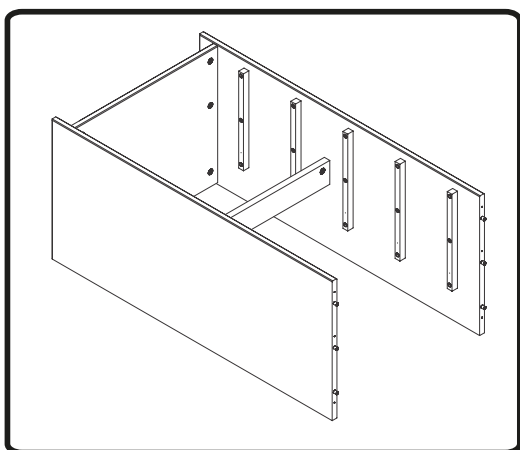
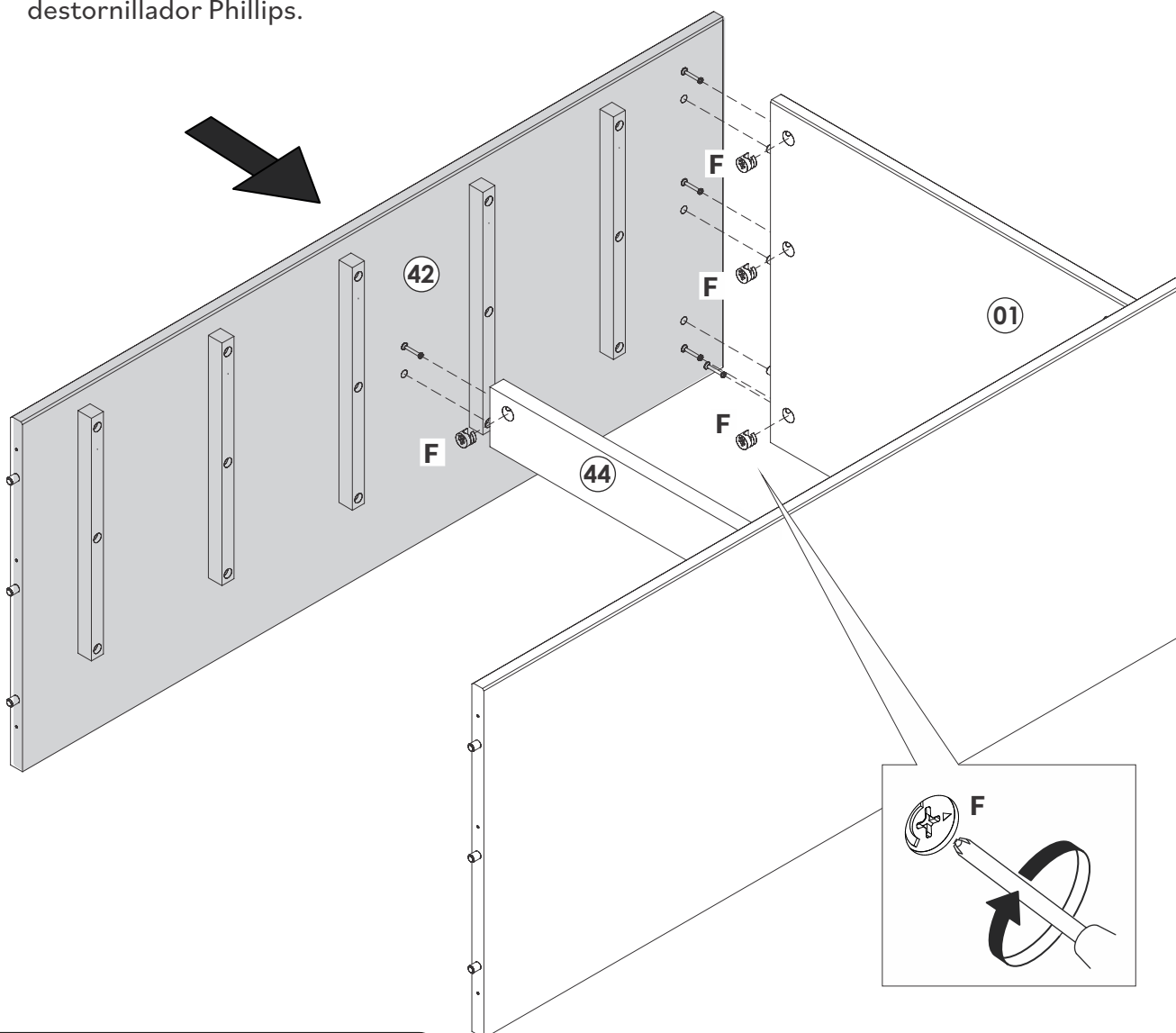

# Étape / Paso 8

(FR)

Fixez le Panneau inférieur (04) au Panneau latéral gauche (42) et au Panneau latéral droit (43) à l'aide de la Vis (C) et d'un tournevis cruciforme.

(ES)

Asegure el Panel inferior (04) al Panel lateral izquierdo (42) y al Panel lateral derecho (43) usando el Tornillo (C) y un destornillador Phillips.

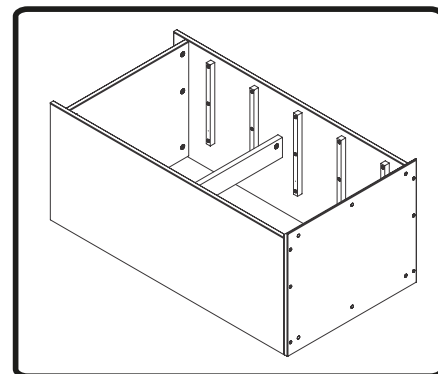
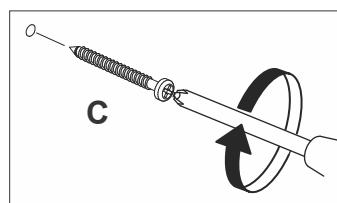
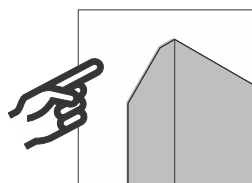
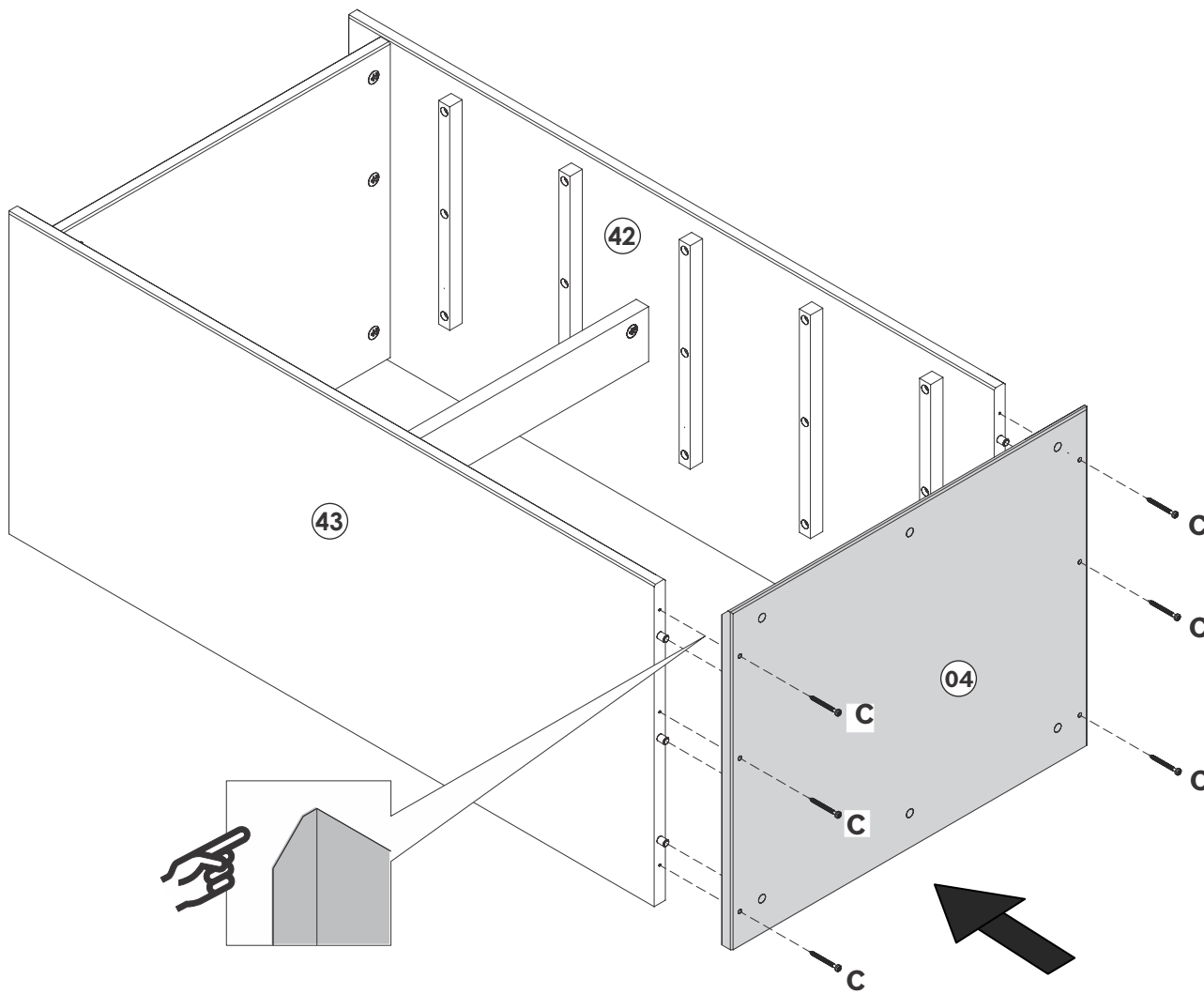
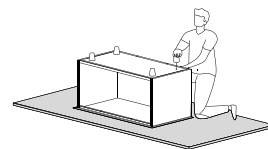

## Étape / Paso 9

(FR)

Fixez le Barre avant inférieure (34) au Pied (36) avec la Vis (C) et un tournevis cruciforme.

(ES)

Asegure el Travesaño frontal inferior (34) al Pie (36) con el Tornillo (C) y un destornillador

Phillips.

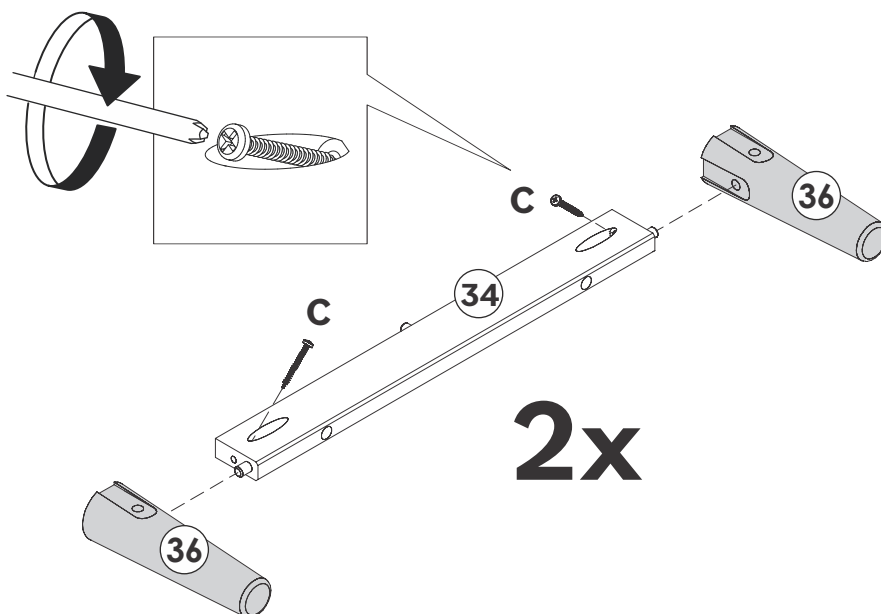
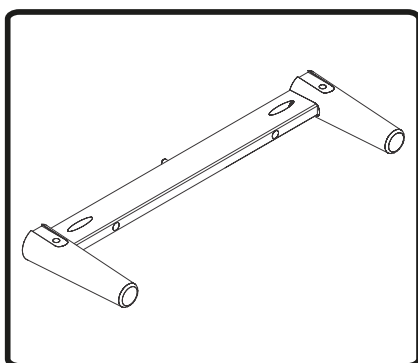
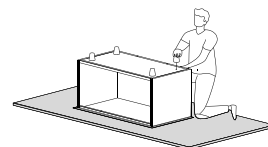

## Étape / Paso 10

(FR)

Fixez le Barre latéral inférieur (35) au Pied (36) avec la Vis (C) et un tournevis cruciforme.

(ES)

Asegure el Travesaño lateral inferior (35) al Pie (36) con el Tornillo (C) y un destornillador Phillips.

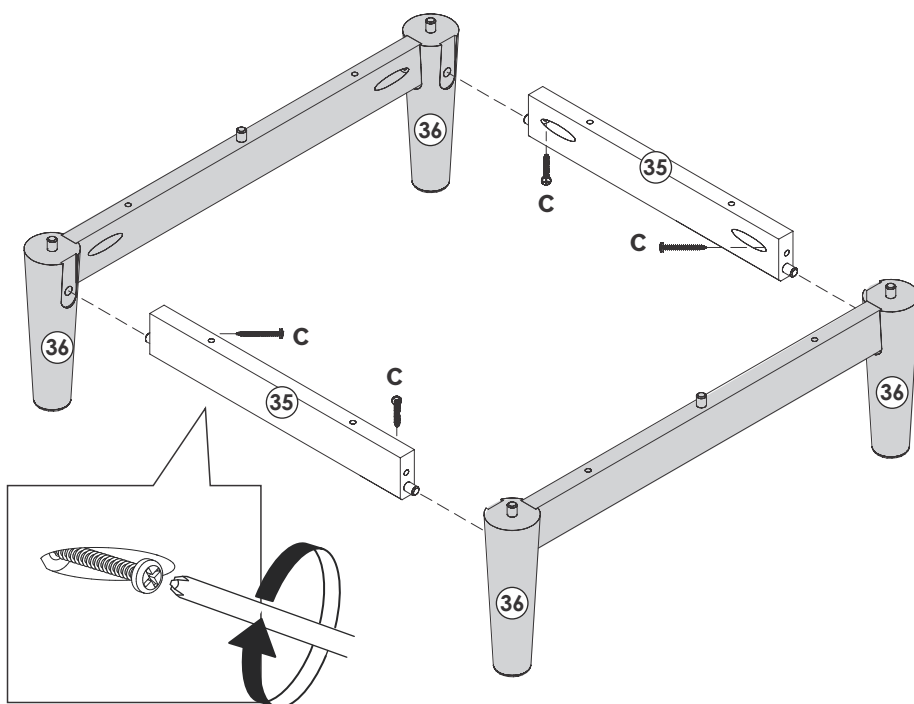
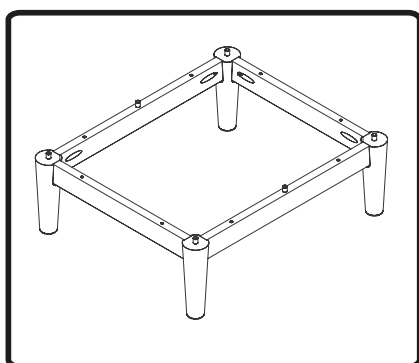

# Étape / Paso 11

(FR)

Joindre le Barre avant inférieur (34) et le Pied (36) au Panneau inférieur (04). Fixer le Barre avant inférieur (34) et le Barre latéral inférieur (35) au Panneau inférieur (04) à l'aide de la Vis (C) et d'un tournevis cruciforme.

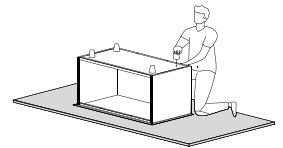

(ES)

Una el Travesaño frontal inferior (34) y el Pie (36) al Panel inferior (04). Fije el Travesaño frontal inferior (34) y el Travesaño lateral inferior (35) al Panel inferior (04) usando el Tornillo (C) y un destornillador Phillips.

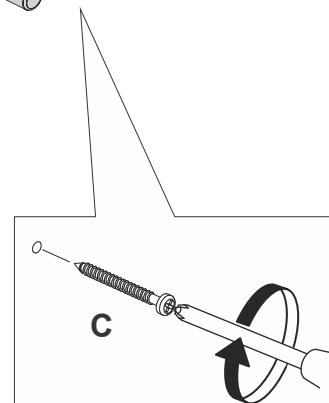
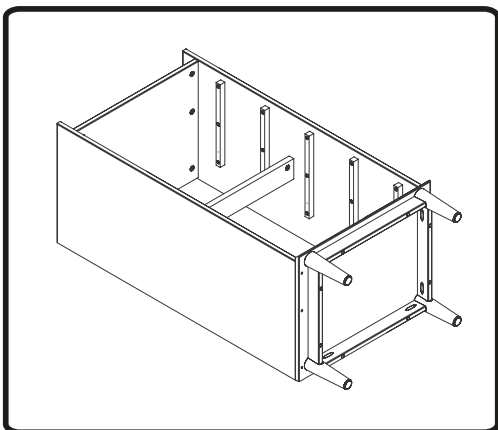
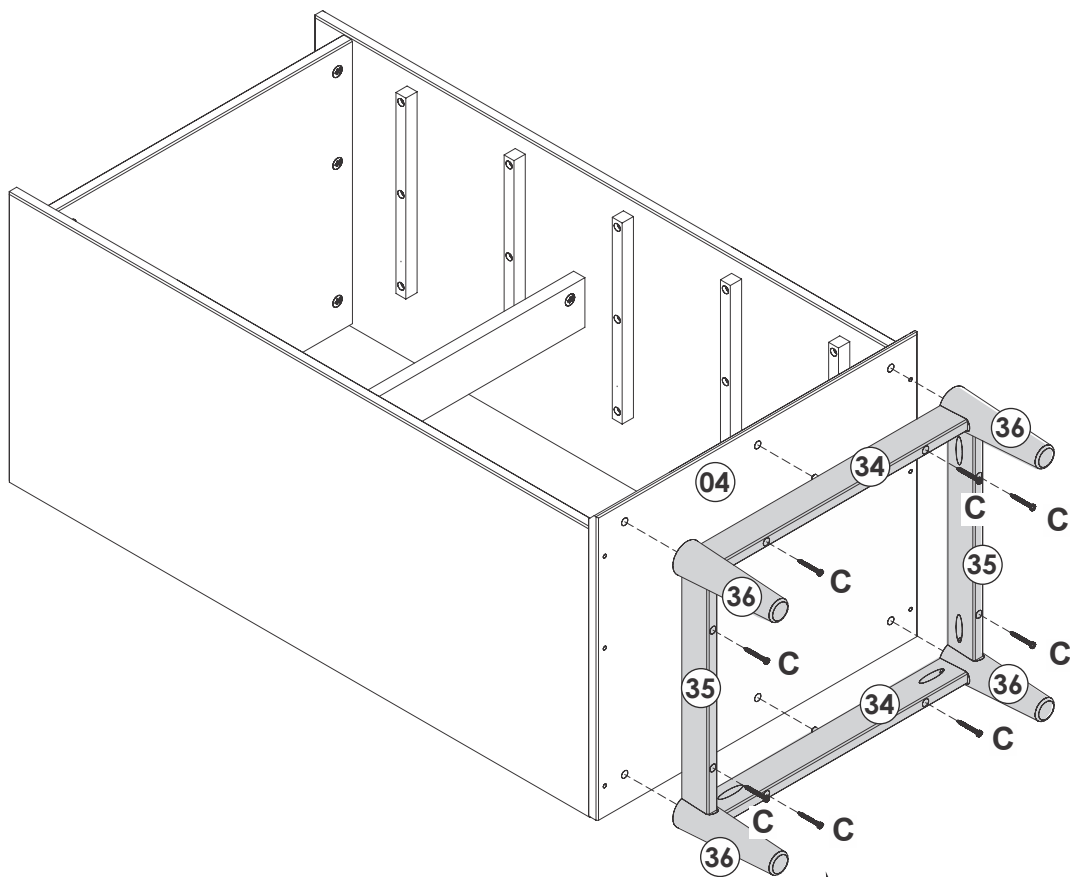

# Étape / Paso 13

(FR)

Insérez le Boitier (F) dans le trou du Barre supérieur (15) et fixez-le avec un tournevis cruciforme.

(ES)

Inserte la Traba (F) en el orificio del Travesaño superior (15) y fíjelo con un destornillador Phillips.

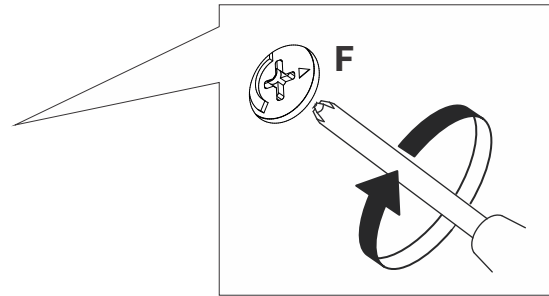
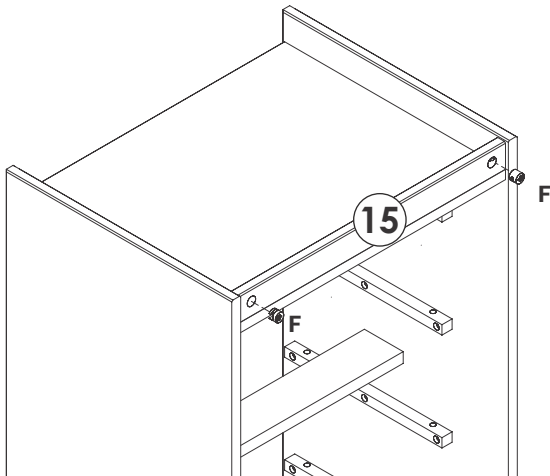
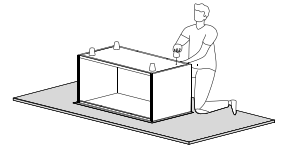

# Étape / Paso 14

(FR)

Installez le Panneau arrière (16) dans le Panneau supérieur (01), Panneau inférieur (04), Panneau latéral gauche (42) et Panneau latéral droit (43). Fixez Panneau arrière (16) au Panneau supérieur (01) et au Panneau inférieur (04) à l'aide de la Vis (H) et d'un tournevis cruciforme.

(ES)

Coloque el Panel trasero (16) en el Panel superior (01), Panel inferior (04), Panel lateral izquierdo (42) y Panel lateral derecho (43). Fije el Panel trasero (16) al Panel superior (01) y al Panel inferior (04) con el Tornillo (H) y un destornillador Phillips.

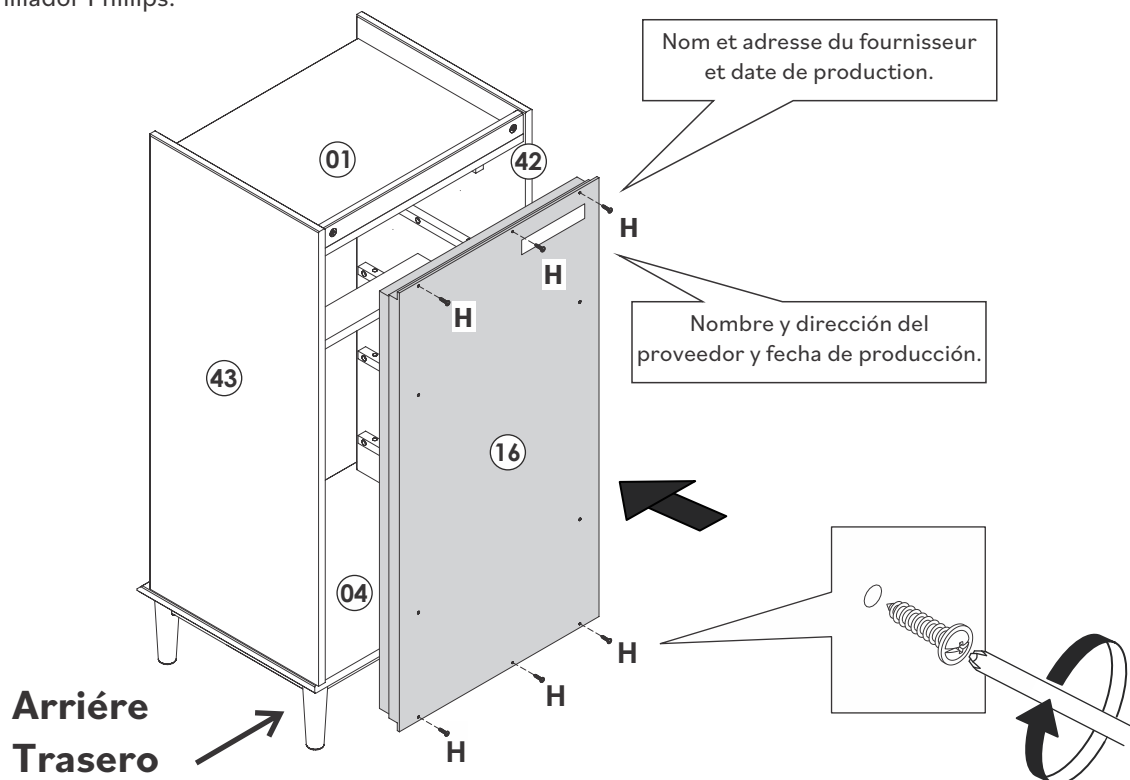



# Étape / Paso 14

(FR)

Insérez la Cheville en bois (A) dans le trou avant du Glissière (17).

(ES)

Inserte la Espiga de madera (A) en el orificio frontal de la Corredera (17).

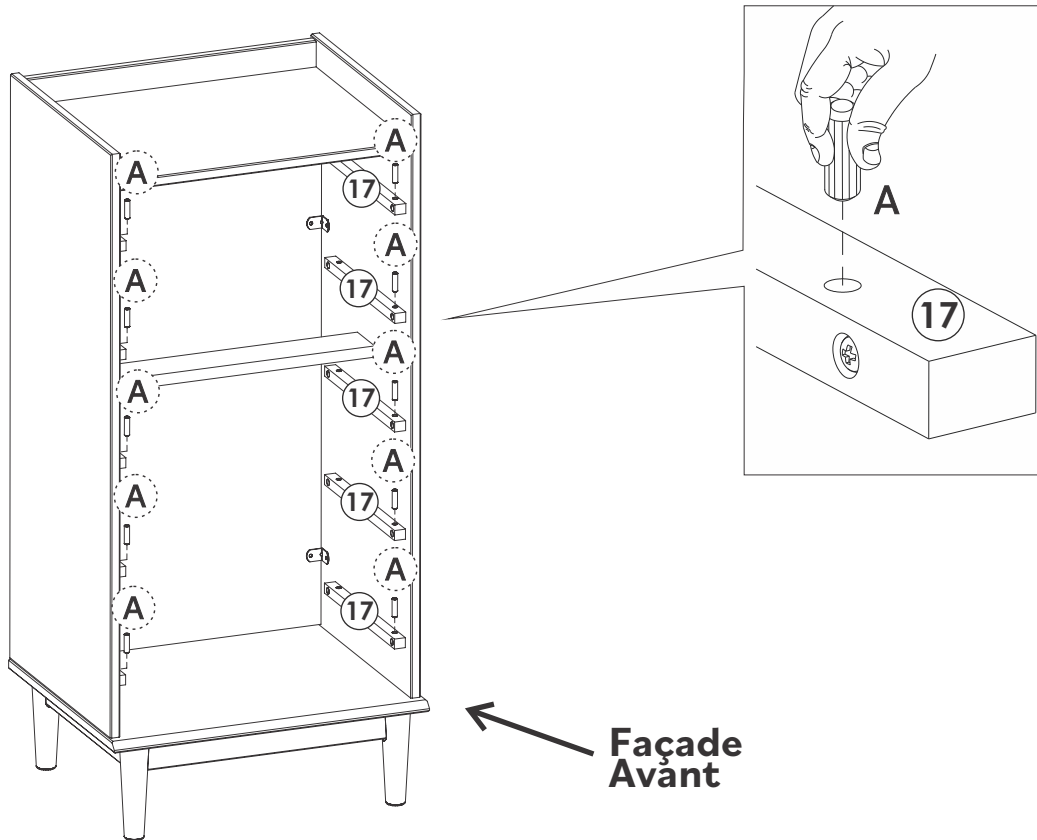
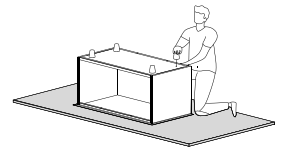

# Étape / Paso 15

(FR)

Fixez le Côté gauche du tiroir (05), Côté droit du tiroir (06) et Côté droit du tiroir avec Avertissement (07) à la Façade du tiroir (08) à l'aide des Boitiers (F).

(ES)

Fije el Lado izquierdo del cajón (05), Lado derecho del cajón (06) y Lado derecho del cajón con Advertencia (07) al Frente del cajón (08) usando Trabas (F).

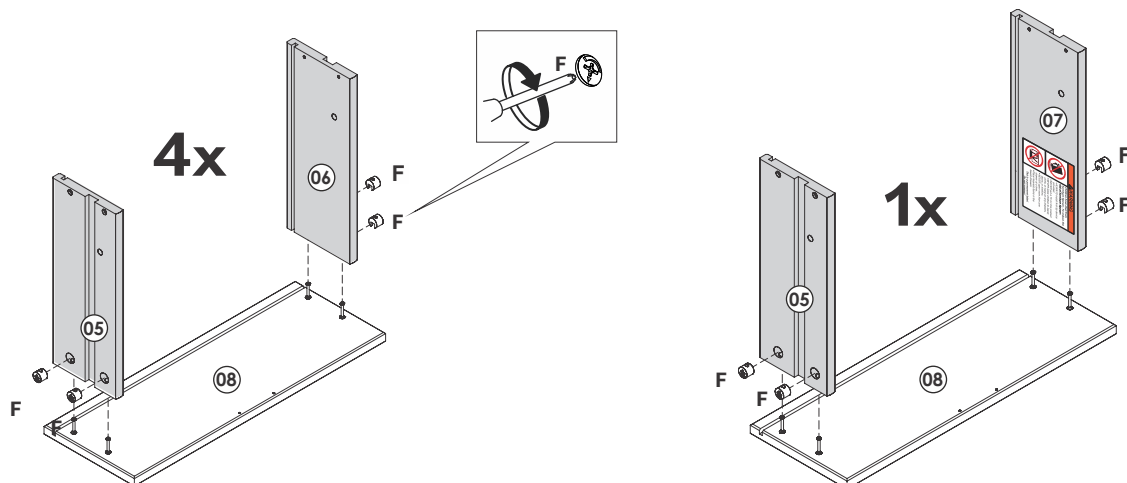

# Étape / Paso 16

(FR)

Faites glisser le Fond du tiroir (48) dans les rainures du Côté gauche du tiroir (05), du Côté droit du tiroir (06) et du Côté droit du tiroir avec Avertissement (07), et insérez-le dans la Façade du tiroir. Fixez l'Arrière du tiroir (10) avec la Vis (E) et un tournevis cruciforme.

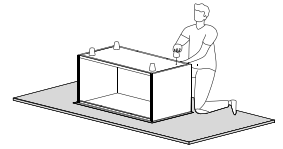

(ES)

Deslice la Parte inferior del cajón (48) en las ranuras del Lado izquierdo del cajón (05), Lado derecho del cajón (06) y Lado derecho del cajón con advertencia (07), y colóquelo en el Frente del cajón. Fije la parte Trasera del cajón (10) con el tornillo (E) y un destornillador Phillips.

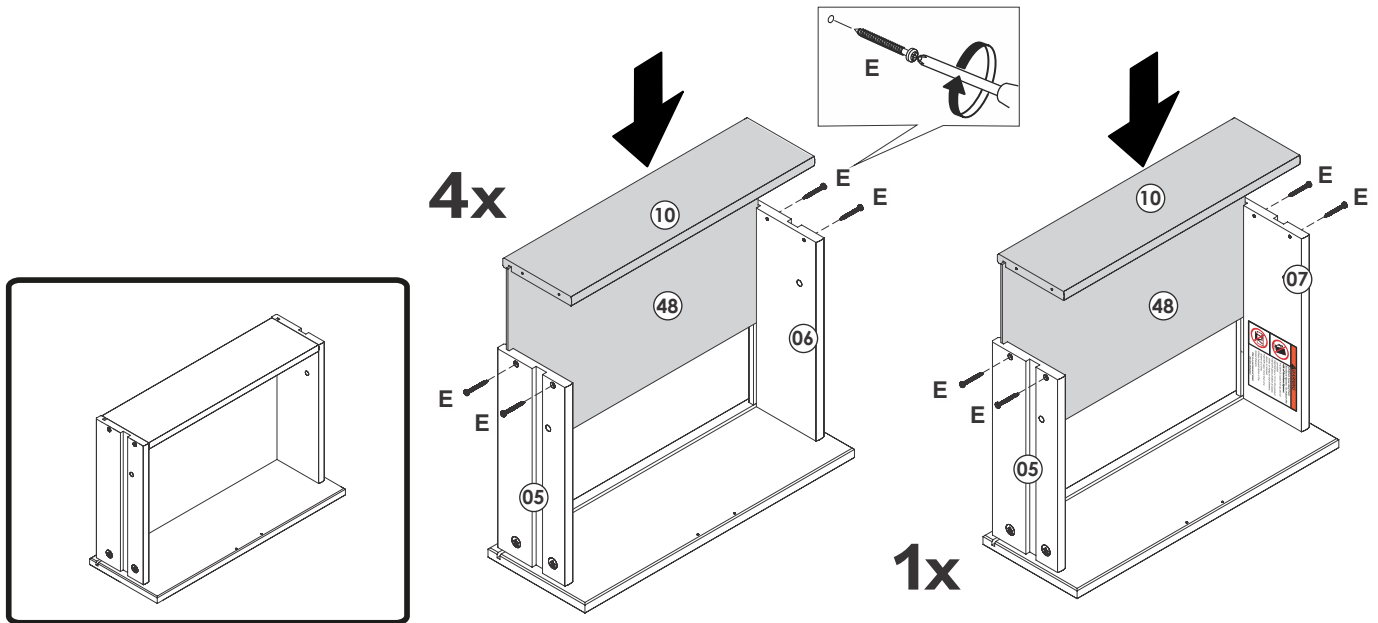

# Étape / Paso 17

(FR)

Fixez la Poignée (N) avec la Vis (D) et le tournevis cruciforme.

(ES)

Coloque la Manija (N) con el Tornillo (D) y un destornillador Phillips.

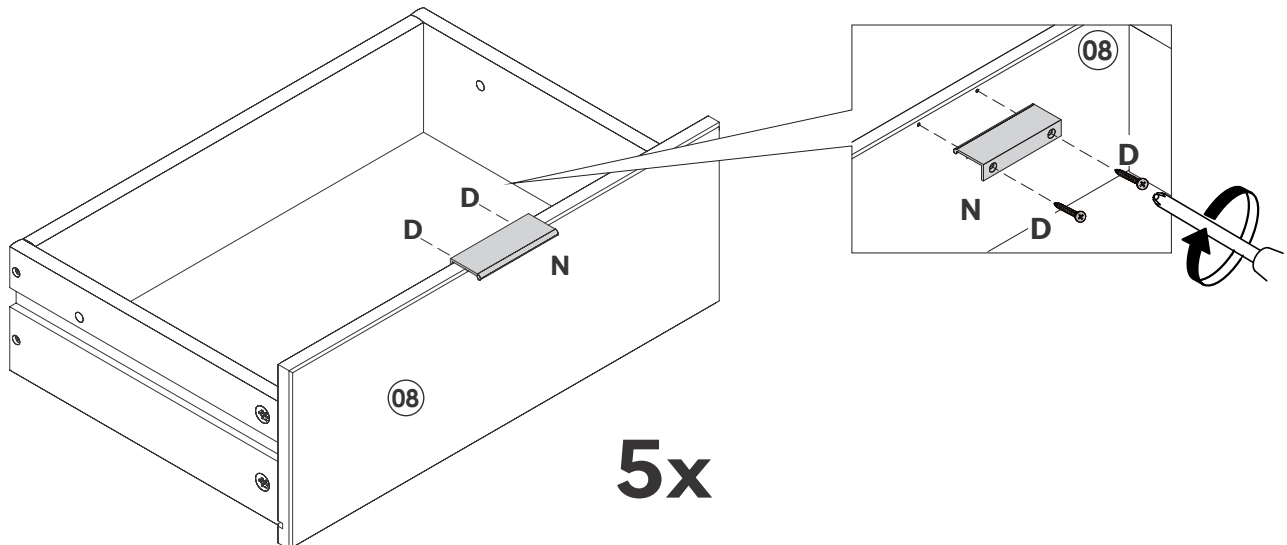

# Étape / Paso 18

(FR)

Placez chaque tiroir un par un à l'intérieur de l'unité, en vous assurant d'avoir passé la cheville en bois qui se trouve sur la glissière du tiroir. Ensuite, insérez les chevilles en bois (I) en place à l'intérieur des tiroirs. Remarque : n'enfoncez pas la cheville jusqu'au bout.

Elle dépassera légèrement dans le tiroir, ce qui vous permettra de la retirer si nécessaire.

(ES)

Coloque cada cajón dentro de la unidad, de a uno por vez, asegurándose de pasar la clavija de madera que se encuentra en la corredera del cajón. Luego, inserte las Espigas de madera (I) en su lugar dentro de los cajones. Tenga en cuenta: No empuje la clavija hasta el fondo. Sobresale levemente dentro del cajón, por lo que podrá quitarla si es necesario.

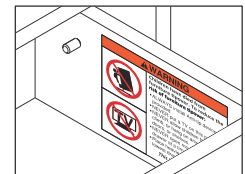
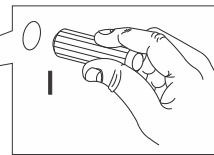
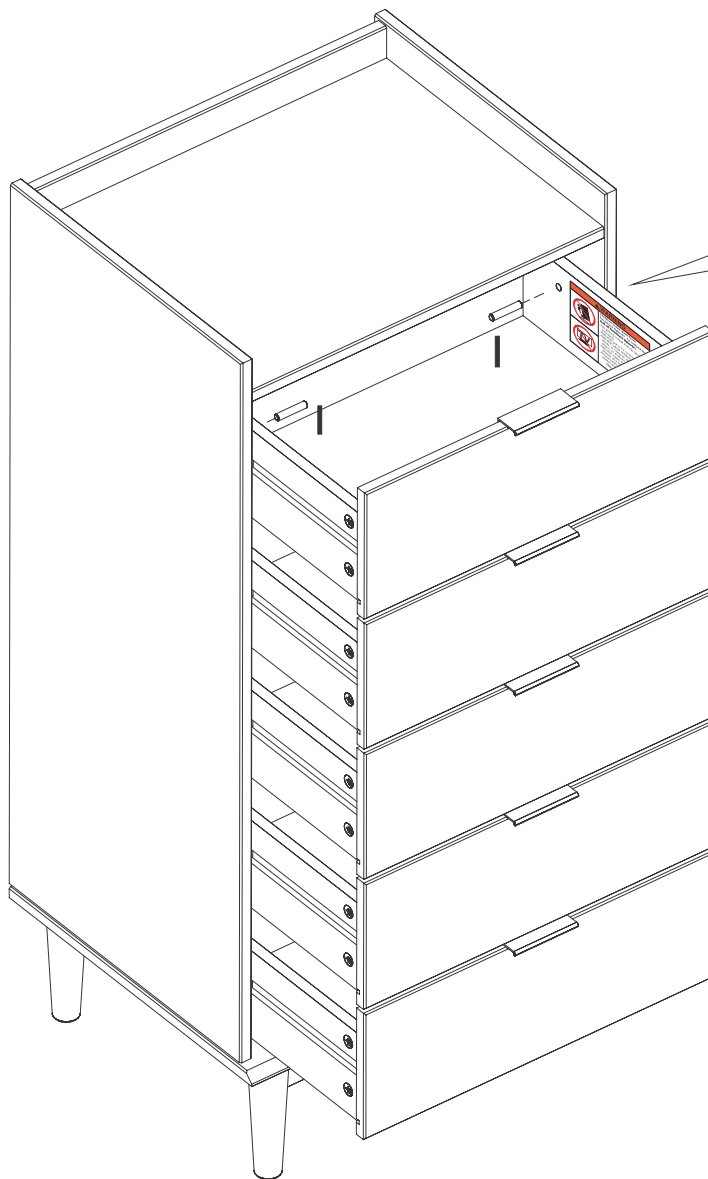
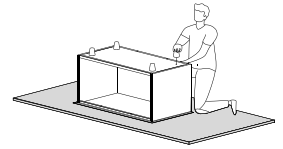

Le tiroir monté avec cette notice doit être placé sur le dessus de l'unité.

El cajón montado con este aviso debe colocarse en la parte superior de la unidad.

# Étape / Paso 19

## 6MIKJ: D: EK

9/, %, /√, Ž+Œ, rQ!√ & (+/%, r)//Œ' -, /+Œ' !+/' ~, /√' Œ+ /&/' - / & // %, oG (/+ Œ- /+\* // % & // %' / ~ /%r' (/√~ (& & ' i (' / / % 2+ i ' !-Œ & /' - / & /+oQW ~ + Ž / & /+ %- %, ' /-√, ~ (& ) ( ' - , (' - ! ~ %, i ' ' , ~ /) + ( / !-o6, /√j- (!\* // %, ~ (& ) ( ' - , , (' - i ' ) - , x- / , & /+ ' Œ' - %√, - %%-! (' r ~ + i ! √' -, & ' - # / 2 i / & /+ ) // Œ' - ' ~ / , !- /+ i ! √' -, -3) / , i W ~ + Ž / o

## 69MIK: E8x6

G//i/' (~ /+!+%, !(' / , Ž+Œ, ( fi - %, / / % ! ( ' % ~ i ' i / & // %, oG' + / Œ- /+\* // ( , & // %, / ~ ! Ž ' r √~ (& /' i & ( , \* // , / ' ' ) /+ & ' /' - / & /' - /' % ) √ i r o % ' ~ % // i / ) √ i 3%, Ž /+ ' ' / , /-Œ! ~ % ! i ( , /' / , - / ) + ( / ~ - (o6, / Ž + - / / \* // %, Ž /+ ' ' / , /' ' i / ~ / i ( , ) + - / , ) √ i / , ' ' - / , / / % ! , - % ! ' r 3' \* // i ! √ √' - / , & ' - # % , / / ) √ i / / ) // i /' √ \* // #+ i ! √ √' - / , - ! ) ( , / / ' ~ % // , o

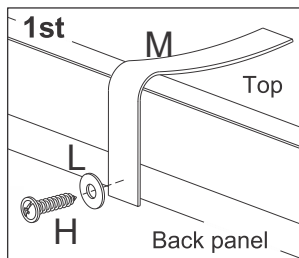

### ! 1st

Fixez l'ruban (N) avec la Vis (H) et la Rondelle (O) à l'arrière du Panneau supérieur (01) à l'aide du tournevis cruciforme.  
Fije la Cinta (N) con el Tornillo (H) y la Arandela (O) a la parte posterior del Panel superior (01) usando el destornillador Phillips.

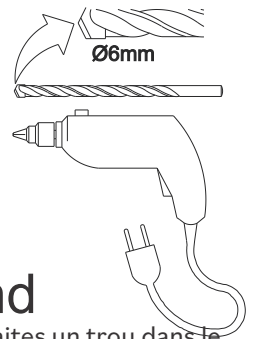

### ! 2nd

À l'aide de la perceuse, faites un trou dans le mur et insérez le Douille (K) dans le trou. Fixez l'ruban (N) avec la Vis (J) et la Rondelle (O) au mur à l'aide du tournevis cruciforme.  
Con el taladro, haga un agujero en la pared e inserte el Casquillo (K) en el agujero. Fije la Cinta (N) con el Tornillo (J) y la Arandela (O) a la pared usando el destornillador Phillips.

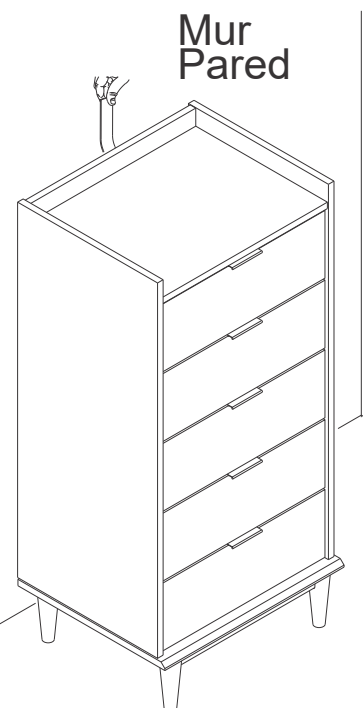
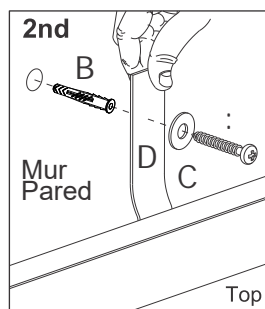
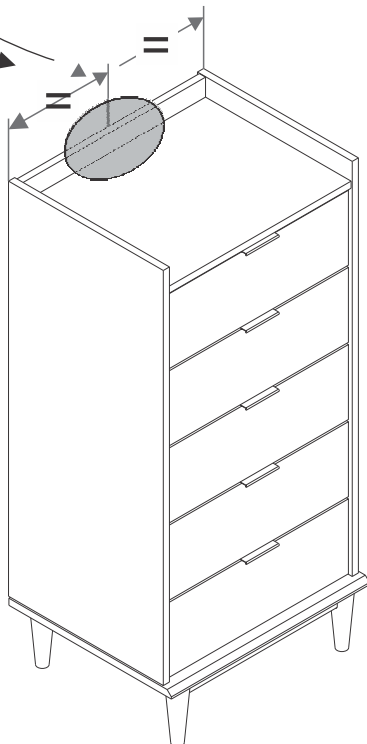

Le nom et l'adresse du fabricant responsable du matériel anti-basculement ainsi que la date de production se trouvent sur l'étiquette au dos du meuble.

El nombre y la dirección del fabricante responsable de los herrajes antivuelco y la fecha de producción se pueden encontrar en la etiqueta ubicada en la parte posterior del mueble.

**Vous avez réussi ! Profitez de votre nouvelle commode !  
Lo has conseguido! Disfruta de tu nueva cómoda !**

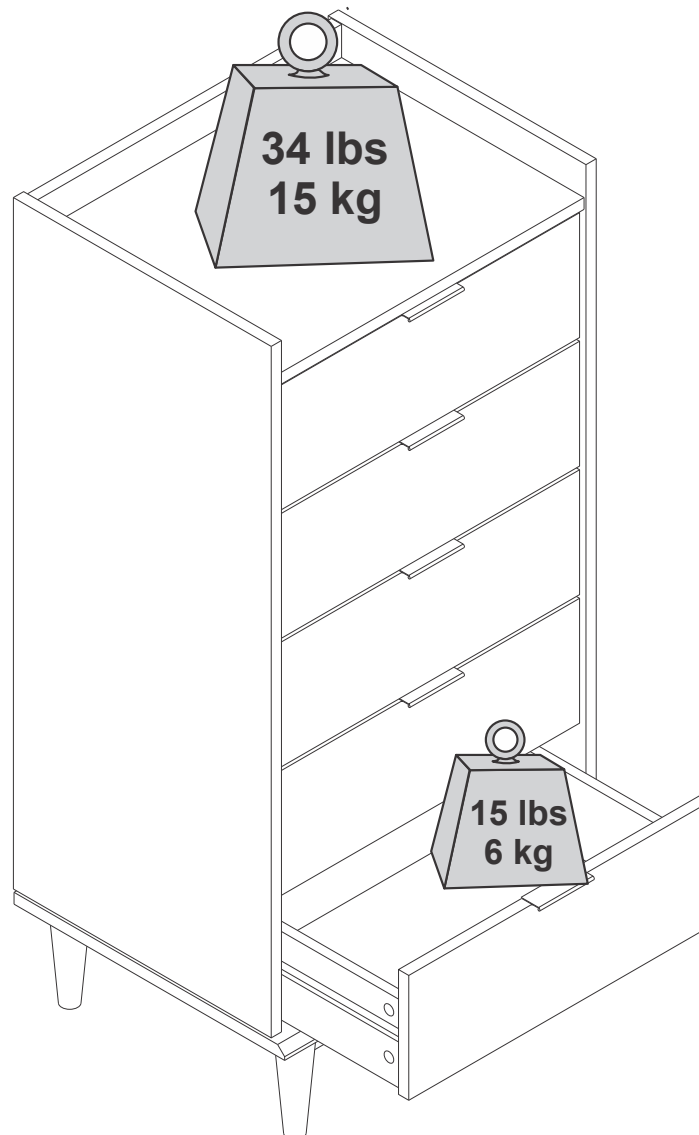

**Félicitations pour votre nouveau meuble!  
Nous serions ravis d'en entendre parler et de le voir.  
Laissez-nous un commentaire ou postez une photo  
avec le mot-clé #mywalkerredisonhome**

**Enhorabuena por su nuevo mueble!  
Nos encantaría conocerlo y verlo.  
Por favor, déjenos un comentario o  
publique una foto con #mywalkerredisonhome**

## Assembler des meubles peut parfois être compliqué.

Notre équipe de service client, située dans l'Utah, est là pour obtenir des informations sur les produits, aider pour l'assemblage d'un produit ou pour tout autre problème de support client.

Appelle-nous **801-433-3008**

Envoie-nous les e-mails à **[service@walkeredison.com](mailto:service@walkeredison.com)**

Visite notre site accueil au client à

**[walkeredison.com/pages/customer-service](http://walkeredison.com/pages/customer-service)**

Nous sommes disponibles pour t'aider du Lundi au Jeudi de 8 am - 5 pm, Vendredi de 8 am - 3 pm MST.

Pour plus de détails sur les vidéos d'assemblage, les instructions d'assemblage, les pièces de rechange et le service client.

**NUMÉRISER ICI.**



Pour le nettoyage, n'utilise jamais d'abrasifs, utilise un chiffon doux et de l'eau avec du savon neutre pour nettoyer les meubles

## A veces, montar muebles puede resultar complicado.

Nuestro equipo de atención al cliente, ubicado en Utah, está a su disposición para informarle sobre los productos, ayudarle a montarlos o resolver cualquier otro problema de atención al cliente.

Llámenos **801-433-3008**

Envíenos un correo electrónico a **[service@walkeredison.com](mailto:service@walkeredison.com)**

Visite nuestra página web de atención al cliente

**[walkeredison.com/pages/customer-service](http://walkeredison.com/pages/customer-service)**

Estamos a su disposición para ayudarle de lunes a jueves de 8:00 a 17:00, viernes de 8:00 a 15:00 MST.

Para más detalles sobre videos de montaje, instrucciones de montaje, piezas de recambio y servicio de atención al cliente

**ESCANEE AQUÍ**



Para la limpieza, nunca utilice productos abrasivos, utilice un paño suave y agua con jabón neutro para limpiar los muebles.