

2.1-Gallon Square Container with EZ Cover®

Multiple Uses

Dry Products

Product Codes

Container: **S026**

Description: 2.1-gallon square can

Cover: **STDR**

Description: Tamper-evident, square EZ Cover® with Ring Pull™

Features

Built in hand grips
 Gauge: 60 mil.
 Nominal capacity: 2.1 USG / 8.0 L
 Stack performance: 150 lbs.*
 Tare weights: Body: .81 lbs. / .37 kgs.
 Cover: .37 lbs. / .17 kgs.

Note: *Ratings will be reduced with uneven load distribution.

Specifications with Cover

Dimensions: 9-15/16" X 9-15/16" X 7-5/8"H
 Maximum capacity: 2.2 USG / 8.3 L
 Tare weight: 1.18 lbs. / .54 kgs.

Colors

Standard: White, Black, Natural and Clear
 Custom: Available at manufacturer's discretion

Decorating Options

Silk - Screening: 5"W X 3-1/2"H
 Four or six* color offset printing
 Print area: 4-1/2"W X 3-1/2"H
 Sleeve or pressure sensitive labeling

Note: *Where available

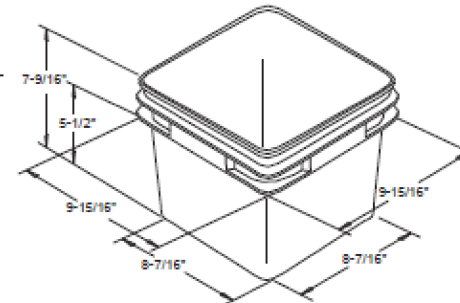
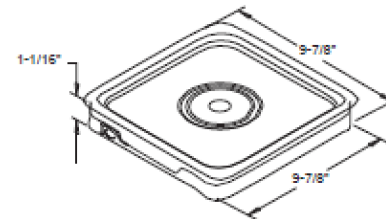

Shipping Data

| | Bodies | Covers |
|-----------------------------|----------|------------------------|
| Qty. per pallet: | 400 | 2,304 (24 boxes of 96) |
| Gross Weight (lbs./kgs.)**: | 324/148 | 852.5/391.7 |
| Den. (lbs./C.F./kgs./m3): | 6.0/97.2 | 8.0/129.9 |
| Length (in./cm.): | 51/129.5 | 51/129.5 |
| Width (in./cm.): | 41/104.1 | 41/104.1 |
| Height (in./cm.): | 44.5/113 | 89/223.6 |

Filled Containers

120 (20 per layer / 6 layers high)
 Pallet height: 49.5"

Estimated truckload quantity of 16,000 bodies and covers***

Notes: *Bulk pack also available
 **Weight does not include pallet/packaging
 ***Truckload quantity based on 53' trailer

Materials

FDA approved materials
 Resin: Body: High-Density Polyethylene (HDPE)
 or Clear Polypropylene (PP)
 Cover: High-Density Polyethylene (HDPE)
 MSDS Sheets available upon request

Optional Carrying Handle

DISCLAIMER

THIS INFORMATION IS PROVIDED AS A GENERAL GUIDE, INCLUDING DIMENSIONS. IT IS THE CUSTOMER'S RESPONSIBILITIES TO SELECT THE PROPER CONTAINER FOR PRODUCT AND APPLICATION COMPATIBILITY.

DISTRIBUTED BY:



REF NO.:

DWG10138

DESCRIPTION:

2 gallon HDPE Open Head Pail