



MANUFACTURED BY:
 Backyard Discovery
 3305 Airport Drive, Pittsburg, KS 66762
 800-856-4445

Basepoint Business Centre: Rivermead Drive, Westlea, Swindon SN5 7EX Phone: 0800-118-2476
 J.P. Coenstraat 7, The Bridge, The Hague, 2595 WP, Netherlands Phone: 0800-567-8990

ECHO HEIGHTS

PLAYHOUSE

Model # 2102316

The assembly manual must be retained since it contains important information.



WARNING

Adult Assembly Required.

Not suitable for children under 2 years due to small parts.

FOR DOMESTIC USE ONLY. INTENDED FOR OUTDOOR USE.

CAN ICES-003 (B)/NMB-003(B)



Please visit www.backyarddiscovery.com

For the most up to date assembly manual, to register your set, or to order replacement parts

Para obtener instrucciones en español, visite www.backyarddiscovery.com



EASY STEP-BY-STEP
3D INTERACTIVE INSTRUCTIONS

DOWNLOAD THE FREE APP



INSTALLATION SERVICES AVAILABLE!

See inside for details

Made in China

INS-2102316B-ECHO HEIGHTS-ENG 03/16/23



GOCONFIGURE
Putting it all together for you

INSTALLATION SERVICES AVAILABLE!*

Need a helping hand?

Let our team of professionals handle the installation for you!

GOCONFIGURE
888-888-5424

**Installation services are only available
to U.S. customers.*

With Go Con! gure, we bring you 18 years of experience right to your doorstep. We service a wide array of indoor and outdoor recreation products that most consumers don't have the time or ability to deliver & install themselves.

We do the heavy lifting, so you don't have to!

-
- 18+ Years of Experience Servicing Big Box Retailers and Direct Consumers
 - Highly Skilled, Specialized, Courteous, Professional Service Technicians
 - Over 140,000 Installations Annually
 - White Glove Service

- Satisfaction Guarantee
 - Flexible Appointments, including weekends
 - Coverage across the nation
- Visit www.goconfigure.com for more info!**
-

**Installation services are only available to U.S. customers.*



The store where you made your purchase does not stock parts for this item. If you have assembly questions or you are missing or have damaged parts, please call

1-800-856-4445

you can also visit www.backyarddiscovery.com
or e-mail customerservice@backyarddiscovery.com

Please have the following information ready when you make your call:

- Model Number of the product located on the front of the assembly manual
 - The item description and number from the parts list from the manual that was included in your box
-
- Read entire assembly manual, paying special attention to the important tips and safety information.
 - Ensure there are no missing pieces by first separating and identifying all parts.
 - Make sure to check packing material for small parts that may have fallen out during shipment.
 - Structures are not intended for public use. Any unintended use such as home child care, daycare center, faith center, government facility, home owner's associate, park or school will make the warranty of our product null & void.
 - This manual contains helpful information concerning assembly preparation, installation procedure and required maintenance.
 - Always keep safety in mind as your structure is being built.
 - Keep these instructions for future reference.



THE MANUFACTURER RESERVES THE RIGHT TO MAKE SUBSTITUTIONS TO WARRANTY CLAIMS IF PARTS ARE UNAVAILABLE OR OBSOLETE

This Limited Warranty by Backyard Discovery applies to products manufactured under the Backyard Discovery brand or its other brands including but not limited to Adventure Playsets, and Leisure Time Products.

Backyard Discovery Wood Play Structure

Backyard Discovery warrants this wooden play product to be free from defects in materials and workmanship for a period of two (2) years from the original date of purchase. All wood carries a five (5) year warranty against rot and decay from the original purchase date.

Backyard Discovery Metal Play Structure

Backyard Discovery warrants this metal play product to be free from defects in materials and workmanship for a period of five (5) years from the original date of purchase.

General Warranty Information

This warranty applies to the original owner and registrant and is non-transferable. Regular maintenance is required to ensure maximum life and performance of this product. Failure by the owner to maintain the product according to the maintenance requirements may void this warranty. Maintenance guidelines are provided in the Owner's Manual.

This Limited Warranty does not cover:

- Natural occurring properties of wood such as twisting, warping, checking, peeling or any other natural occurring properties of wood that do not affect performance or integrity.
- Installation – the warranty is null and void if installation is not in accordance with the Assembly Instructions.
- Labor for any inspection
- Labor for replacement of any defective item(s)
- Incidental or consequential damages
- Cosmetic defects, including rusting, color fading, minor cracks, corrosion, which do not affect performance or integrity of a part or the entire product.
- Vandalism, improper use, failure due to loading or use beyond the capacities stated in the applicable Assembly Manual.
- Acts of nature including but not limited to wind, storms, hail, floods, excessive water exposure.
- Improper installation including but not limited to installation on uneven, unlevel, or soft ground.

Backyard Discovery products have been designed for safety and quality. Any modifications made to the original product could damage the structural integrity of the unit leading to failure and possible injury. Modification voids any-and-all warranties and Backyard Discovery assumes no liability for the modified products or consequences resulting from failure of a modified product. Backyard Discovery disclaims all other representations and warranties of any kind, express or implied.

This product is warranted for RESIDENTIAL USE ONLY. Under no circumstance should a Backyard Discovery product be used in public settings (public settings include but are not limited to churches, day cares, parks, etc.). Such use may lead to product failure and potential injury. Any and all public use will void this warranty.

USA and Canada: To make a warranty or replacement part claim please visit backyarddiscovery.com or call Backyard Discovery customer service at 800-856-4445. Backyard Discovery will, at its sole discretion, replace any part within the stated warranty period that is defective in workmanship or materials. At Backyard Discovery's discretion, photographs of the defective part, physical return of the defective part to Backyard Discovery, or proof of purchase may be required for verification.

Outside of the USA and Canada: Contact place of purchase or distributor for warranty service.

This Warranty gives you specific legal rights. You may have other rights as well which vary from state to state, province to province or country to country, where you bought the product. This warranty excludes all consequential damages however, some states do not allow the limitation or exclusion of consequential damages and therefore this limitation may not apply to you.

Please read entire booklet completely before beginning the assembly process

Please retain these instructions and your receipt for future reference. Keep them in a safe place where you can refer to them as needed. In order to provide you with the most efficient service, it is required that you provide us with the part numbers when ordering parts.

For Your Records:

Please take time and fill out the information below. This information will be needed for warranty issues.

Where Purchased: _____
 Date of Purchase: _____
 Installation Date: _____
 Installed by: _____
 Tracking Number: _____

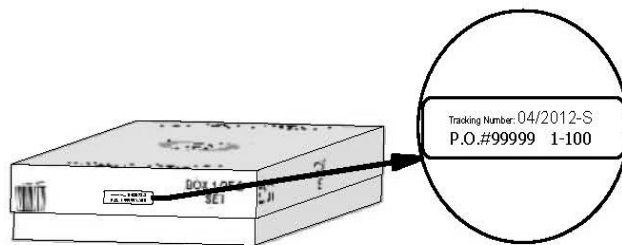

Tracking Number Reference Label

Tracking ID number on the carton and on the bottom of the vertical ID plate are included for tracking purposes associated with warranty claims.



NOTE:

Your Children's Safety Is Our #1 Concern!

Observe the following statements and warnings to reduce the likelihood of serious or fatal injury. Please review these safety rules regularly with your children.



WARNING:

BURN HAZARD

- Pay special attention to plastic and metal surfaces as they may be hot enough to cause burns.
- Always check the temperature of the product before letting your children play on it.
- Remember that the product may cause burns if left in direct sunlight.
- Always be aware of the sun and weather conditions, and do not assume that the equipment is safe because the air temperature is not very high.

- Equipment is recommended for use by children 2 to 10 years of age.
- On-site adult supervision is required.
- Instruct children not to climb when the equipment is wet.
- Instruct children to never crawl on top of a play house roof.
- The parents should have the children dress appropriately with well-fitting shoes. Loose clothing such as scarves and ponchos should not be worn. Always take off , tie up or tuck in cords and drawstrings on children's clothing. These things can get caught on playground equipment and strangle a child.
- Do not allow children to walk, in front, between, behind or close to moving rides.
- Instruct children not to attach items to the equipment that are not specifically designed for use with that equipment (such as ropes, clothesline, pet leashes, etc.).
- Instruct children to remove their bike or other sports helmet before playing on the playground equipment.
- Do not allow children to go down slide head first or run up slide.
- Instruct children to **look** before they slide to make sure no one is at the bottom.
- On sunny and/or hot days, check the slide and other plastic rides to assure that they are not hot to the touch to cause burns. Cool hot slide and rides with water and wipe dry prior to using.
- Children must wear shoes when using the set. Do not allow children to wear open toe or heel footwear like sandals, flip-flops or clogs



Positioning Your Playhouse

- The playhouse is designed to be installed on a level surface by an Adult with an Adult helper. Place in a flat area of your yard to minimize ground preparation.
- Choose a level location for the equipment. This can reduce the likelihood of the playhouse tipping over and loose-fill surfacing material washing away during heavy rains.
- Place the equipment not less than 6'-7" (2.0 m) from any structure or obstruction such as a fence, garage, house, overhanging branches, laundry lines, or electrical wires.
- It is a good idea to place your playhouse in an area that is convenient for adults to watch children at play.
- Create a site free of obstacles that could cause injuries – such as low overhanging tree branches, overhead wires, tree stumps and/or roots, large rocks, bricks and concrete. We have additional suggestions in the Suggested Playground Surfacing Section.
- Do not build your playhouse on top of surfacing material.

Suggested Playground Surfacing

- Do not install home playground equipment over concrete, asphalt, packed earth, grass, carpet, or any other hard surface. A fall onto a hard surface can result in serious injury to the equipment user.
- Do not install loose fill surfacing over hard surfaces such as concrete or asphalt.
- Shredded bark mulch, wood chips, fine sand and fine gravel, are added as shock absorbing materials after assembly. If used properly these materials can absorb some of the impact of a child's fall.
- All surface material should extend a minimum of 6 feet in all directions around the play area.
- Do not apply playground surfacing until after the unit is completely constructed. Play house should not be built on top of surfacing.
- Use containment, such as digging out around the perimeter and/or lining the perimeter with landscape edging.
- Installations of rubber tiles or poured-in-place surfaces (other than loose-fill materials) generally require a professional and are not "do-it-yourself" projects.
- Shall use Playground Surfacing Materials (other than loose-fill material) which comply with the safety standard ASTM F1292 Standard Specification of Impact Attenuation of Surfacing Materials within the Use Zone of Playground Equipment.

The following chart explains the fall height in feet from which a life threatening head injury would not be expected

Critical Heights in feet (m) of Tested Materials

Material	Uncompressed Depth			Compressed Depth to 9" (228mm)
	6" (152mm)	9" (228mm)	12" (304mm)	
Wood Chips	7' (2.13m)	10-12' (3.0-3.6m)	11' (3.35m)	10' (3.05m)
Double-Shredded Bark Mulch	6' (1.83m)	10-12' (3.0-3.6m)	11' (3.35m)	7' (2.13m)
Engineered Wood Fibers	6' (1.83m)	7' (2.13m)	>12' (3.66m)	6' (1.83m)
Fine Sand	5' (1.52m)	5' (1.52m)	9' (2.74m)	5' (1.52m)
Coarse Sand	5' (1.52m)	5' (1.52m)	6' (1.83m)	4' (1.22m)
Fine Gravel	5' (1.52m)	7' (2.13m)	10' (3.05m)	6' (1.83m)
Medium Gravel	5' (1.52m)	5' (1.52m)	6' (1.83m)	5' (1.52m)
Shredded Tires*	10-12' (3.0-3.6m)	N/A	N/A	N/A

*This data is from tests conducted by independent testing laboratories on a 6-inch depth of uncompressed shredded tire samples produced by four manufacturers. The tests reported critical heights, which varied from 10 feet to greater than 12 feet. It is recommended that persons seeking to install shredded tires as a protective surface request test data from the supplier showing the critical height of the material when it was tested in accordance with ASTM F1292.



APPENDIX A

The following information is from the United States Consumer Product Safety Commission's Information Sheet for playground surfacing material; also see the following website for additional information: www.cpsc.gov

X3. SECTION 4 OF THE CONSUMER PRODUCT SAFETY COMMISSION'S OUTDOOR HOME PLAYGROUND SAFETY HANDBOOK⁹

X3.1 Select Protective Surfacing—One of the most important things you can do to reduce the likelihood of serious head injuries is to install shock-absorbing protective surfacing under and around your play equipment. The protective surfacing should be applied to a depth that is suitable for the equipment height in accordance with ASTM Specification F 1292. There are different types of surfacing to choose from; whichever product you select, follow these guidelines:

X3.1.1 Loose-Fill Materials:

X3.1.1.1 Maintain a minimum depth of 9 inches of loose-fill materials such as wood mulch/chips, engineered wood fiber (EWF), or shredded/recycled rubber mulch for equipment up to 8 feet high; and 9 inches of sand or pea gravel for equipment up to 5 feet high. NOTE: An initial 12 inch level of 12 inches will compress to about a 9-inch depth of surfacing overtime. The surfacing will also compact, displace, and settle, and should be periodically refilled to maintain at least a 9-inch depth.

X3.1.2 Use a minimum of 6 inches of protective surfacing for play equipment less than 4 feet in height. If maintained properly, this should be adequate. (At depths less than 6 inches, the protective material is too easily displaced or compacted.)

NOTE: Do not install home playground equipment over concrete, asphalt, or any other hard surface. A fall onto a hard surface can result in serious injury to the equipment user. Grass and dirt are not considered protective surfacing because wear and environmental factors can reduce their shock absorbing effectiveness. Carpeting and thin mats are generally not adequate protective surfacing. Ground level equipment such as a sandbox, activity wall, playhouse or other equipment that has no elevated play surface – does not need any protective surfacing.

X3.1.3 Use containment, such as digging out around the perimeter and/or lining the perimeter with landscape edging. Don't forget to account for water drainage.

X3.1.3.1 Check and maintain the depth of the loose-fill surfacing material. To maintain the right amount of loose-fill materials, mark the correct level on play equipment support posts. That way you can easily see when to replenish and/or redistribute the surfacing.

X3.1.3.2 Do not install loose-fill surfacing over hard surfaces such as concrete or asphalt.

X3.1.4 Poured-In-Place Surfaces or Pre-Manufactured Rubber Tiles — You may be interested in using surfacing other than loose-fill materials – like rubber tiles or poured-in-place surfaces.

X3.1.4.1 Installations of these surfaces generally require a professional and are not “do-it-yourself” projects.

X3.1.4.2 Review surface specification before purchasing this type of surfacing. Ask the installer/manufacturer for a report showing that the product has been tested to the following safety standard: ASTM F 1292 Standard Specification for Impact Attenuation of Surfacing Materials within the Use Zone of Playground Equipment. This report should show the specific height for which the surface is intended to protect against serious head injury. This height should be equal to or greater than the fall height – vertical distance between a designated play surface (elevated surface for standing, sitting, or climbing) and the protective surfacing below – of your play equipment

X3.1.4.3 Check the protective surfacing frequently for wear.

X3.1.5 Placement — Proper placement and maintenance of protective surfacing is essential. Be sure to:

X3.1.5.1 Extend surfacing at least 6 feet from the equipment in all directions.

X3.1.5.2 For to-and-fro swings, extend protective surfacing in front of and behind the swing to a distance equal to twice the height of the top bar from which the swing is suspended.

⁹This information has been extracted from the CPSC publications “Playground Surfacing — Technical Information Guide” and “Handbook for Public Playground Safety.” Copies of these reports can be obtained by sending a postcard to the: Office of Public Affairs, U.S. Consumer Product Safety Commission, Washington, D.C., 20207 or call the toll-free hotline: 1-800-638-2772.

The American Society for Testing and Materials takes no position respecting the validity of any patent right asserted in connection with any item mentioned in this standard. Users of this standard are expressly advised that determination of the validity of any such patent rights, and the risk of infringement of such rights, are entirely their own responsibility.

The standard is subject to revision at any time by the responsible technical committee and must be reviewed every five years and if not revised, either approved or withdrawn. Your comments are invited either for revision of this standard or for additional standards and should be addressed to ASTM Headquarters. Your comments will receive careful consideration at a meeting of the responsible technical committee, which you may attend. If you feel that your comments have not received a fair hearing you should make your views known to the ASTM Committee on Standards, 100 Barr Harbor Drive, West Conshohocken, PA 19428.



IT IS IMPORTANT TO CHECK AND TIGHTEN ALL HARDWARE AT THE BEGINNING AND DURING THE SEASON AS THEY MAY LOOSEN DUE TO WOOD EXPANSION AND CONTRACTION.

At the beginning of each play season

- Tighten all hardware.
- Lubricate all metallic moving parts per manufacturer's instructions.
- Check all protective coverings on bolts, pipes, edges, and corners. Replace if they are loose, cracked, or missing.
- Check all moving parts including swing seats, ropes, cables, and chains for wear, rust, or other deterioration. Replace as needed.
- Check metal parts for rust. If found, sand and repaint using a non lead-based paint meeting the requirements of 16 CFR 1303.
- Check all wood members for deterioration and splinters. Sand down splinters and replace deteriorating wood members.
- Reinstall any plastic parts, such as swing seats or any other items that were removed for the cold season.
- Rake and check depth of loose fill protective surfacing materials to prevent compaction and to maintain appropriate depth. Replace as necessary.

Twice a month during play season

- Tighten all hardware.
- Check all protective coverings on bolts, pipes, edges, & corners. Replace if they are loose, cracked, or missing.
- Rake and check depth of loose fill protective surfacing materials to prevent compaction and to maintain appropriate depth. Replace as necessary.

Once a month during play season.

- Lubricate all metallic moving parts per manufacturer's instructions.
- Check all moving parts including swing seats, ropes, cables, and chains for wear, rust, or other deterioration. Replace as needed.

At the end of each play season or when the temperature drops below 32° F

- Remove plastic swing seats and other items as specified by the manufacturer and take indoors or do not use.
- Rake and check depth of loose fill protective surfacing materials to prevent compaction and to maintain appropriate depth. Replace as necessary.

Additional Maintenance

- Check the swing beam and hardware every two weeks due to wood expansion and contraction. It is particularly important that this procedure be followed at the beginning of each season.
- Inspect wood parts monthly. The grain of the wood sometimes will lift in the dry season causing splinters to appear. Light sand may be necessary to maintain a safe playing environment. Treat your playset with stain regularly, to help prevent severe checking/splitting and other weather damage.
- A waterborne transparent stain has been applied to your playset. This is done for color only. Once or twice a year, depending on your climate conditions, you must apply some type of protection (sealant) to the wood of your unit. Prior to the application of sealant, lightly sand any "rough" spots on your playset. Please note this is a requirement of your warranty.
- Assembling and maintaining the playset on a level location is very important. As your children play, your playset will slowly dig its way into the soil, and it is very important that it settles evenly. Make sure the playset is level and true one each year or at the beginning of each play season.

Disposal Instructions

When the Playcenter use is no longer desired, it should be disassembled and disposed of in such a way that no unreasonable hazards will exist at the time the unit is discarded.



Third Party Assembly

- Customer may, in their sole discretion, elect to use a third party person or service to assemble this product. Backyard Discovery assumes no responsibility or liability for any charge incurred by the Customer for any assembly services. Please see our warranty for more information about damaged and missing part replacement coverage. Backyard Discovery will not reimburse Customer for the price of parts purchased.
- Modifications made by the consumer to the original activity toy shall be carried out according to the instructions of the manufacturer. In particular, instructions shall be provided with kit/accessory about the installation of rope/nets concerning the minimum diameter, the need for fixation ends, overall length, and positioning in relation to other at both structures.

OWNERS SHALL BE RESPONSIBLE FOR MAINTAINING THE LEGIBILITY OF THE WARNING LABELS



Your Backyard Discovery structure is designed and constructed of quality materials. As with all outdoor products it will weather and wear. To maximize the enjoyment, safety and life of your structure it is important that you properly maintain it.

About Our Wood

Backyard Discovery uses 100% Cedar (C. Lanceolata) wood. Although we take great care in selecting the best quality lumber available, wood is still a product of nature and susceptible to weathering which can change the appearance of your set.

What causes weathering? Does it affect the strength of my product?

One of the main reasons for weathering is the effects of water (moisture); the moisture content of the wood at the surface is different than the interior of the wood. As the climate changes, moisture moves in or out of the wood, causing tension which can result in checking and or warping. You can expect the following due to weathering. These changes will not affect the strength of the product:

1. Checking is surface cracks in the wood along the grain. A post (4" x 4") will experience more checking than a board (1" x 4") because the surface and interior moisture content will vary more widely than in thinner wood.

2. Warping results from any distortion (twisting, cupping) from the original plane of the board and often happens from rapid wetting and drying of the wood.

3. Fading happens as a natural change in the wood color as it is exposed to sun-light and will turn grey over time.

How can I reduce the amount of weathering to wood product?

1. Your wood product is coated with a water-based stain. Sunlight will break down the coating, so we recommend applying a water repellent or stain on a yearly basis (see your local stain and paint supplier for a recommended product). You must apply some type of protection (sealant) to the wood of your product. **Please note this is a requirement of your warranty.** Most weathering is just the normal result of nature and will not affect safety. However if you are concerned that a part has experienced a severe weathering problem please call our customer service department for further assistance.

2. Inspect wood parts monthly. The grain of the wood sometimes will lift in the dry season causing splinters to appear. Light sanding may be necessary to maintain a safe environment. Treating your Product with protection (sealant) after sanding will help prevent severe checking/ splitting and other weather damage.



Protrusion Hazard

Incorrect

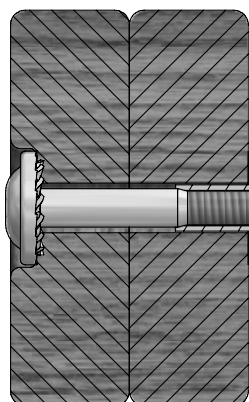

If you see exposed threads and your bolt protrudes beyond the T-Nut you may have overtightened the bolt or used incorrect hardware. If you've overtightened, remove the bolt and add washers to eliminate the protrusion.

Correct

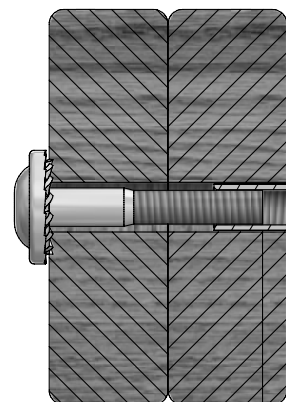

1/8"

Proper Hardware Assembly

Bolt and T-Nut Assembly

Tap T-nut into the provided hole. Insert your bolt through the lock washer and insert into the provided hole opposite from the T-Nut. Turn clockwise to thread into T-nut. Do not completely tighten until instructed.

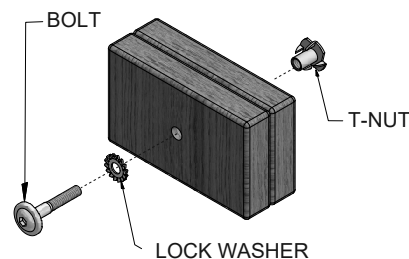

Bolt and Barrel Nut Assembly

Insert barrel nut through the lock washer and press the pair through the provided hole. Insert your bolt through the second lock washer and insert the pair into the provided hole opposite from the barrel nut. Turn clockwise to thread into the barrel nut. Do not completely tighten until instructed.

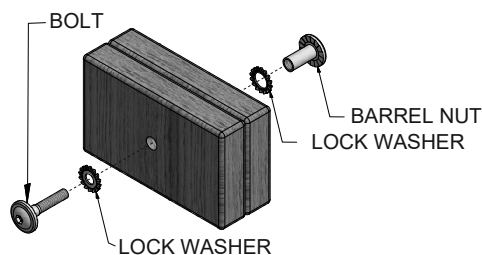

Lag Assembly

Normally there will be a pre-drilled pilot hole on assemblies that require a Lag Screw. If there is no pilot hole, line up the two boards as they are to be attached and use the factory drilled hole as a guide to drill another pilot hole into the adjoining board. This will keep the wood from splitting. Only a lock washer is required for steps with Lag Screws.

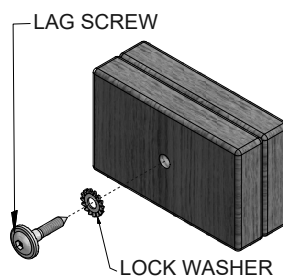



ASSEMBLY TIP:

Keep and eye out for these boxes which will contain helpful pictures and information making the assembly process as quick and painless as possible.

Sorting Wood

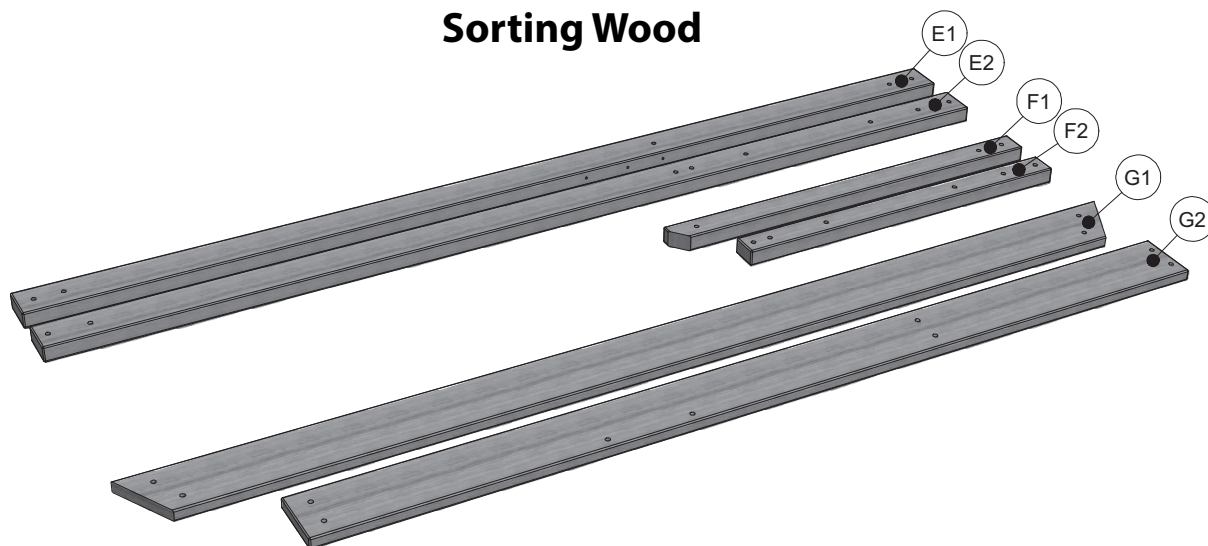

When removing the wood from the boxes we recommend arranging them by part number before you begin assembly. This will allow for faster assembly and easily identify any parts that may be missing or damaged.

Sorting Hardware

NUT BARREL
H100545

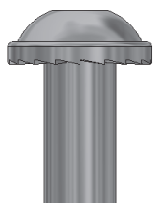

SCREW
H100695

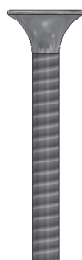

T-NUT
H100699

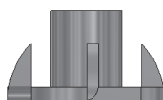

WASHER FLAT
H100706

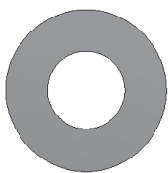

BOLT HEX
H100716

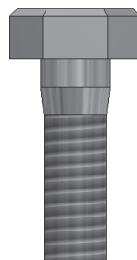

BOLT
H100718



SCREW PWH
H100742

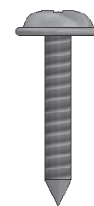

To help with assembly we recommend sorting your hardware bags with the seven digit alpha-numeric number printed on the bags or by hardware type (i.e. bolts, nuts, etc.). Organizing your hardware will make assembly easier.

Hardware Identification

Hardware bags are printed with a seven digit alpha-numeric part number. During assembly you only need to reference the last three digits of the part number as noted in each step. This will make finding the correct hardware easier.

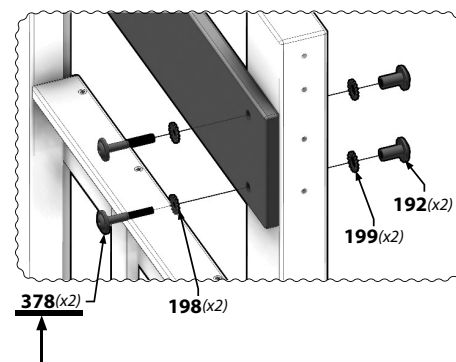
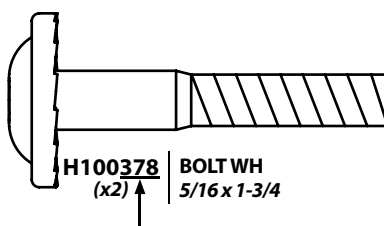

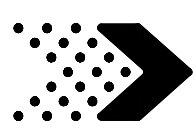

CLASS B DIGITAL DEVICE STATEMENT

Note:

This equipment has been tested and found to comply with the limits for a Class B digital device, pursuant to part 15 of the FCC Rules. These limits are designed to provide reasonable protection against harmful interference in a residential installation. This equipment generates, uses and can radiate radio frequency energy and, if not installed and used in accordance with the instructions, may cause harmful interference to radio communications. However, there is no guarantee that interference will not occur in a particular installation. If this equipment does cause harmful interference to radio or television reception, which can be determined by turning the equipment off and on, the user is encouraged to try to correct the interference by one or more of the following measures:

- Reorient or relocate the receiving antenna.
- Increase the separation between the equipment and receiver.
- Connect the equipment into an outlet on a circuit different from that to which the receiver is connected.
- Consult the dealer or an experienced radio/TV technician for help

Caution: Changes or modifications not expressly approved by the party responsible for compliance could void the user's authority to operate the equipment.

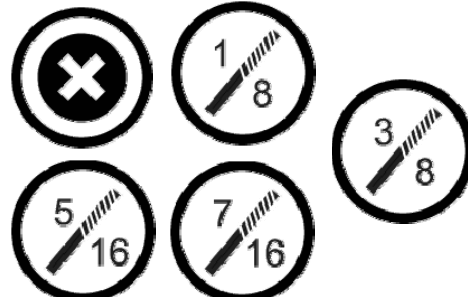
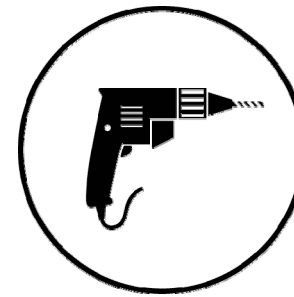
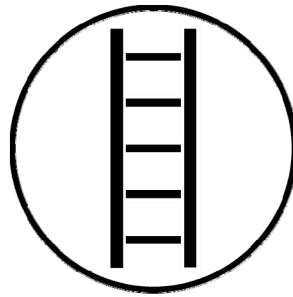
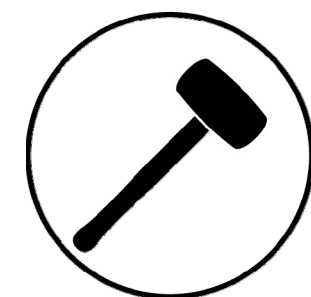
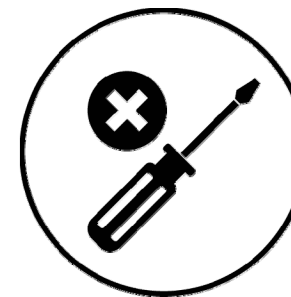
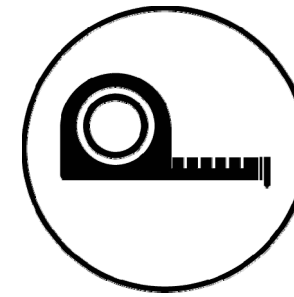
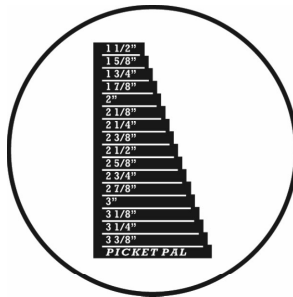
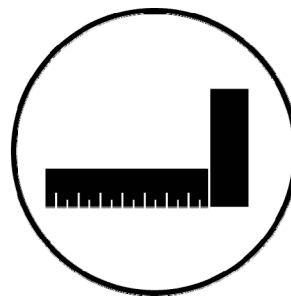
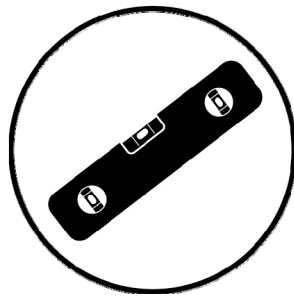
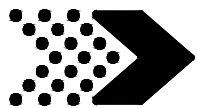

Icons and their uses you will see throughout this manual



You will need to make sure that your assembly is square before tightening your bolts.



When you see this icon you will need a socket wrench. The icons below show the size of attachments needed for assembly 1/2.



For proper assembly you will need to ensure that your structure is level before proceeding to the next step.



This icon warns you to not over tighten your bolts. This is to prevent structural damage and also splintering your wood.



Some steps in the assembly process will require an extra set of hands. Make sure you have a helper available.



A ladder will be needed for assembly. Do NOT stand on the set when it is incomplete, unstable, and not anchored. Failure to do so may result in injury.



This icon shows the size of an open ended wrench. Using the wrench as the fraction bar.



This icon will show you what drill attachments are needed. For this example you will need a Phillips head attachment and 3/8 drill bit.

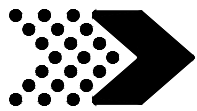

Selecting the correct location for your play product is important for your children's safety and the product's longevity

- The safe play area refers to a zone extending 6'-7" (2m) beyond the play product on all sides, including the space above the play product.

SAFE PLAY AREA DIAGRAM

Ground Dimension

6.25 ft [1.9 m] x 10.02 ft [3.1 m]

Safe Play Area

19.42 ft [5.9 m] x 23.19 ft [7.1 m] x 14.18 ft [4.3 m]

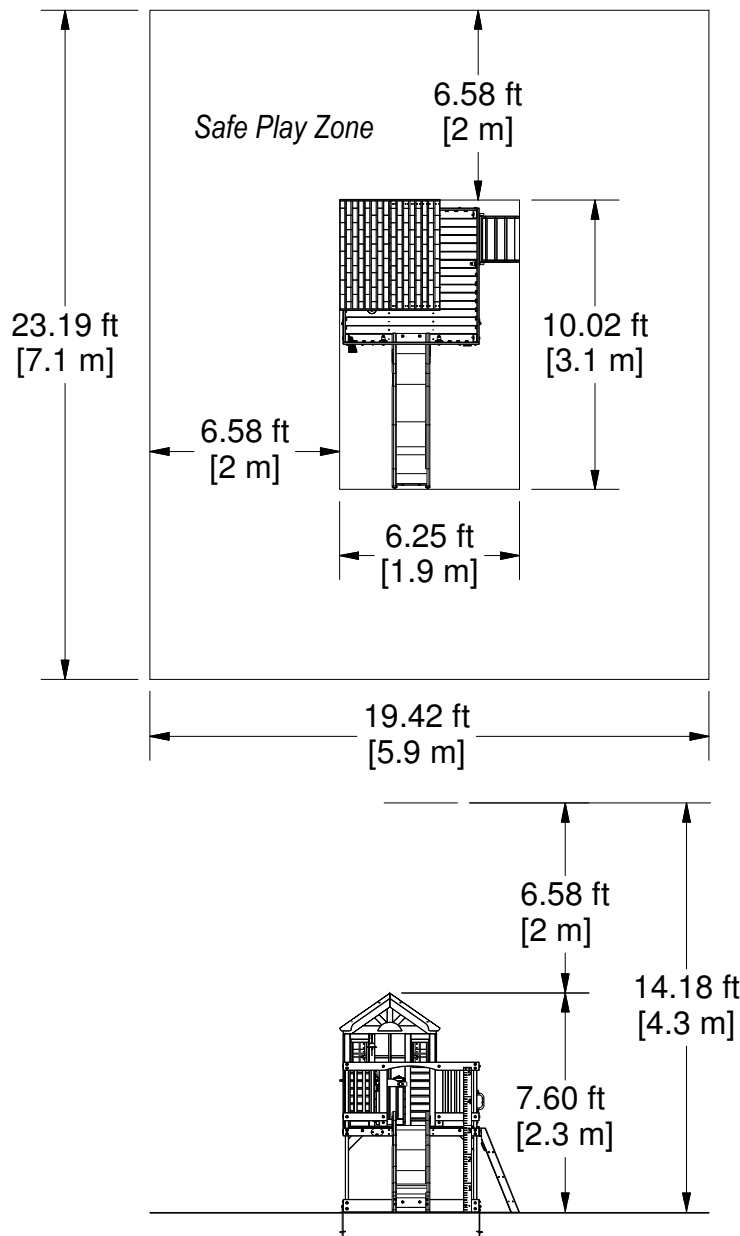

General Information:

Your set has been designed and engineered for children only and for residential use only.
 A maximum of 150 lbs. per child is recommended for play activities designed for individual use.
 A maximum of 120 lbs. per child is recommended for play activities designed for multiple child use.
 A maximum of 6 children is recommended for this playhouse.



Wood Components (Not to Scale)



E1 | LEFT FRONT UPRIGHT - W4L14880
(x1) | 1 3/8"x3 3/8"x62 3/8" (36x86x1584)

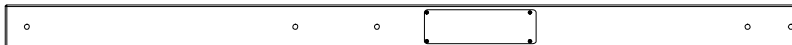

E2 | RIGHT FRONT UPRIGHT - W2A03763
(x1) | 1 3/8"x3 3/8"x62 3/8" (36x86x1584)



E3 | RIGHT REAR UPRIGHT - W4L14882
(x1) | 1 3/8"x3 3/8"x62 3/8" (36x86x1584)



E4 | LEFT REAR UPRIGHT - W4L14883
(x1) | 1 3/8"x3 3/8"x35" (36x86x889)



G1 | GROUND BOARD - W4L14884
(x2) | 1"x5 1/4"x56 3/4" (24x134x1442)



G2 | GROUND BOARD - W4L14885
(x2) | 1"x5 1/4"x54 7/8" (24x134x1394)



H1 | FLOOR RAIL - W4L14888
(x2) | 1"x3 3/8"x56 3/4" (24x86x1442)



H2 | FLOOR RAIL - W4L14889
(x1) | 1"x3 3/8"x54 7/8" (24x86x1394)

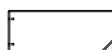

H3 | COUNTER TOP SUPPORT - W4L14919
(x1) | 1"x3 3/8"x8 3/8" (24x86x214)



H4 | FLOOR RAIL - W4L14891
(x1) | 1"x3 3/8"x54 7/8" (24x86x1394)



H5 | FLOOR SUPPORT - W4L14892
(x2) | 1"x3 3/8"x54 7/8" (24x86x1394)



H6 | WALL RAIL - W4L14893
(x2) | 1"x3 3/8"x18 1/2" (24x86x469)



H7 | WALL RAIL - W4L14894
(x1) | 1"x3 3/8"x56 3/4" (24x86x1442)



H8 | WALL RAIL - W4L14895
(x1) | 1"x3 3/8"x34 1/4" (24x86x871)



Wood Components (Not to Scale)



H9 | WALL RAIL - W4L14896
(x2) | 1"x3 3/8"x16 5/8" (24x86x423)



H10 | WALL RAIL - W4L14897
(x2) | 1"x3 3/8"x16 3/4" (24x86x426)



H11 | WALL RAIL - W4L14923
(x1) | 1"x3 3/8"x55 7/8" (24x86x1418)



H20 | DECK BRACE - W4L14898
(x8) | 1"x3 3/8"x13" (24x86x330)



H76 | LADDER RUNG - W4L14899
(x3) | 1"x3 3/8"x18 1/8" (24x86x460)

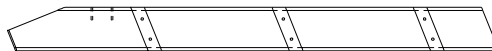

H79 | LEFT UPRIGHT - W4L14900
(x1) | 1"x3 3/8"x38 3/8" (24x86x976)



H80 | RIGHT UPRIGHT - W4L14901
(x1) | 1"x3 3/8"x38 3/8" (24x86x976)



H110 | ATTACHMENT BOARD - W4L14914
(x1) | 1"x3 3/8"x19 1/4" (24x86x488)



J1 | FLOOR SUPPORT BLOCK - W4L14902
(x3) | 1"x3 3/8"x3 3/8" (24x86x86)



J3 | COUNTER TOP SUPPORT - W4L14903
(x2) | 1"x2 3/8"x9 1/4" (24x60x234)

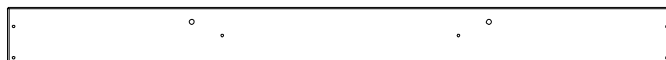

L1 | FLOOR BOARD - W4L14904
(x1) | 5/8"x4 3/8"x52" (16x112x1321)



L2 | FLOOR BOARD - W4L14905
(x1) | 5/8"x4 3/8"x54 3/8" (16x112x1382)

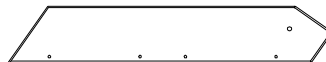

L3 | GABLE BOARD - W4L14906
(x4) | 5/8"x4 3/8"x25 3/8" (16x112x644)

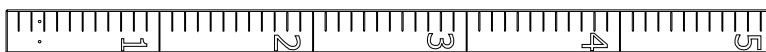

M1 | GROWTH BOARD - W4L14908
(x1) | 5/8"x3 3/8"x60 1/4" (16x86x1530)



Wood Components (Not to Scale)



M4 | FLOOR BOARD - W4L14909
(x13) | 5/8"x3 3/8"x56 3/4" (16x86x1442)



M6 | FLOOR BOARD - W4L14886
(x1) | 5/8"x3 3/8"x56 3/4" (16x86x1442)



M7 | WALL BOARD - W4L14887
(x2) | 5/8"x3 3/8"x26 1/2" (16x86x673)

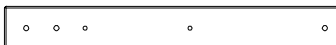

M10 | WALL BOARD - W4L14911
(x1) | 5/8"x3 3/8"x26 1/2" (16x86x673)

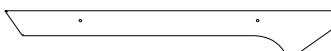

M33 | FASCIA BOARD - W4L14912
(x4) | 5/8"x3 3/8"x25 5/8" (16x86x652)



M73 | REAR SUPPORT - W4L14913
(x1) | 5/8"x3 3/8"x19 1/4" (16x86x488)



M77 | SLIDE BRACE - W4L13297
(x1) | 5/8"x3 3/8"x14 1/4" (16x86x362)

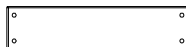

M78 | SLIDE BRACE - W4L13298
(x1) | 5/8"x3 3/8"x14 1/4" (16x86x362)



N1 | TIE STRAP - W4L14915
(x8) | 5/8"x3 3/8"x3 3/8" (16x86x86)



N2 | WINDOW SHELF - W4L14917
(x2) | 5/8"x2 3/8"x19 1/8" (16x60x485)



O1 | PICKET - W4L14918
(x19) | 5/8"x1 3/8"x20 1/2" (16x34x520)



Q1 | COUNTER TOP - W4L14907
(x2) | 1"x4 3/8"x36 3/4" (24x112x934)



S1 | RAIL BOARD - W4L14920
(x2) | 1"x1"x26 3/4" (24x24x679)



S2 | WINDOW TRIM - W4L14921
(x2) | 1"x1"x21 1/2" (24x24x545)



S3 | WINDOW TRIM - W4L14922
(x2) | 1"x1"x23 3/8" (24x24x594)

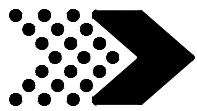

Wood Components (Not to Scale)

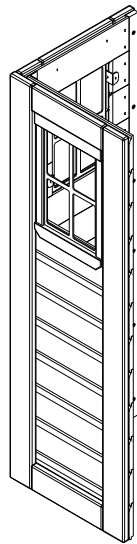

WP1 | FRONT RIGHT CORNER PANEL - W2A03151
(x1)

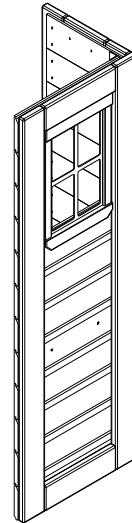

WP2 | REAR RIGHT CORNER PANEL - W2A03154
(x1)

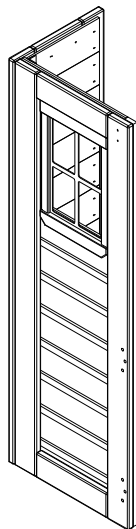

WP3 | FRONT LEFT CORNER PANEL - W2A03157
(x1)

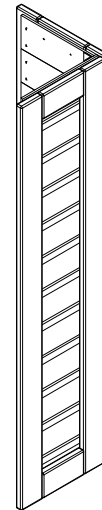

WP4 | REAR LEFT CORNER PANEL - W2A03160
(x1)

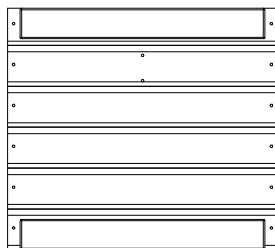

WP5 | REAR CENTER PANEL - W2A03163
(x1) | 1 1/4"x18 7/8"x20 7/8" (32x478x536)

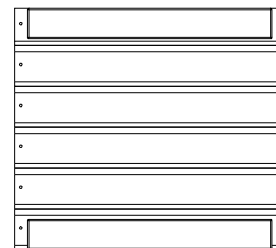

WP6 | LEFT CENTER PANEL - W2A03164
(x1) | 1 1/4"x18 7/8"x20 7/8" (32x478x536)

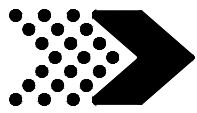

Wood Components (Not to Scale)

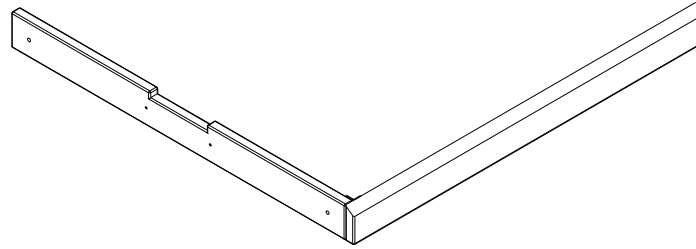

WP8 | HEADER ASSEMBLY - W2A03165
(x2)

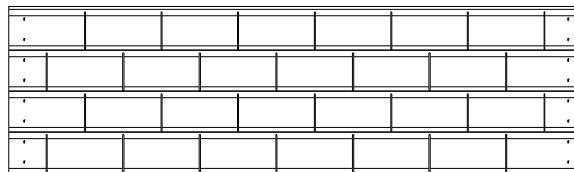

RP1 | LOWER ROOF PANEL - W2A03166
(x2) | 1 3/8"x13"x44 7/8" (35x329x1140)

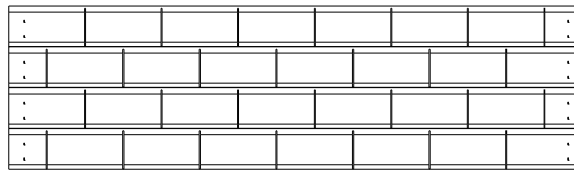

RP2 | UPPER ROOF PANEL - W2A03167
(x2) | 1 3/8"x12 3/4"x44 7/8" (35x324x1140)

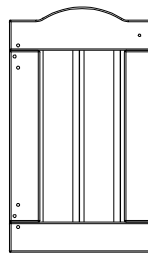

DP1 | DOOR PANEL - W2A03168
(x1) | 1 1/8"x19 1/8"x11 3/8" (27x486x288)



Hardware Components



H100171 | BOLT WH BLK
(x7) | 1/4x1



H100399 | NUT BARREL WH BLK
(x4) | 1/4x7/8



H100469 | NUT BARREL WH BLK
(x8) | 5/16x5/8



H100398 | T-NUT BLK
(x2) | 1/4



H100379 | T-NUT BLK
(x42) | 5/16

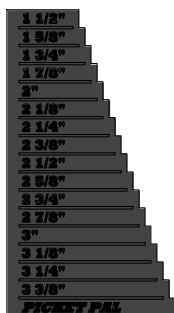

A6P00410 | PICKET PAL
(x1)



H100764 | SCREW SETTER
(x1)



H100484 | BOLT WH BLK
(x3) | 5/16x3 1/4



H100205 | BOLT WH BLK
(x15) | 5/16x2-1/4



H100378 | BOLT WH BLK
(x11) | 5/16x1 3/4



H100407 | BOLT WH BLK
(x7) | 5/16x1 1/2



H100468 | BOLT WH BLK
(x4) | 5/16x1



H100396 | BOLT WH BLK
(x11) | 5/16x1/2



H100114 | TORX WRENCH
(x1) | T-30

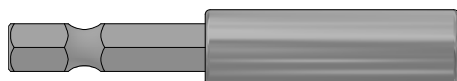

H101100 | MAGNETIC DRIVER
(x1)



H100147 | TORX BIT
(x1) | T-30

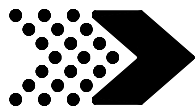

Hardware Components

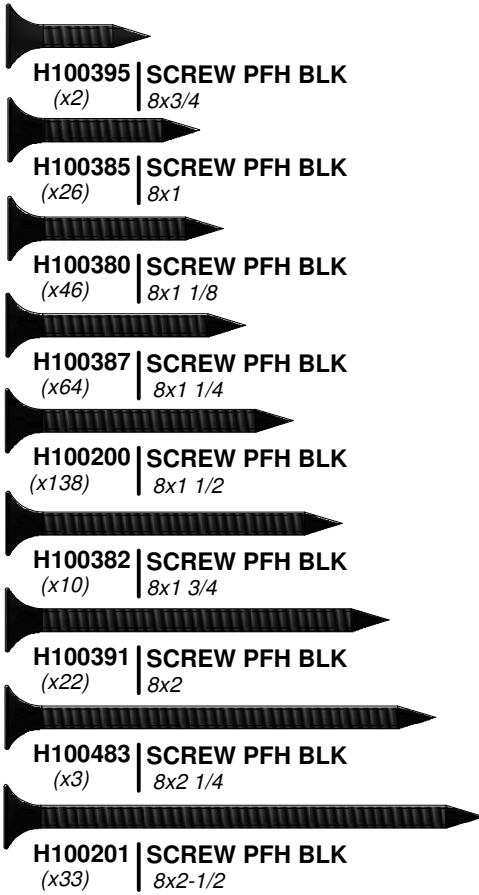

H100395 | SCREW PFH BLK
(x2) | 8x3/4

H100385 | SCREW PFH BLK
(x26) | 8x1

H100380 | SCREW PFH BLK
(x46) | 8x1 1/8

H100387 | SCREW PFH BLK
(x64) | 8x1 1/4

H100200 | SCREW PFH BLK
(x138) | 8x1 1/2

H100382 | SCREW PFH BLK
(x10) | 8x1 3/4

H100391 | SCREW PFH BLK
(x22) | 8x2

H100483 | SCREW PFH BLK
(x3) | 8x2 1/4

H100201 | SCREW PFH BLK
(x33) | 8x2-1/2

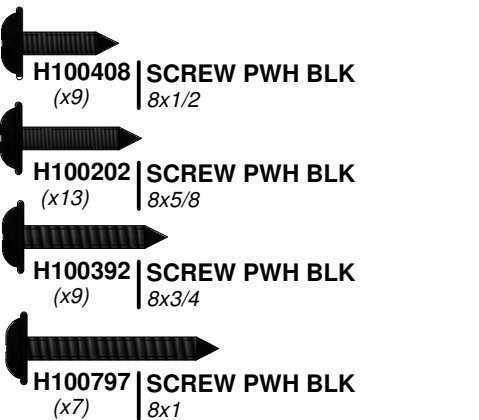

H100408 | SCREW PWH BLK
(x9) | 8x1/2

H100202 | SCREW PWH BLK
(x13) | 8x5/8

H100392 | SCREW PWH BLK
(x9) | 8x3/4

H100797 | SCREW PWH BLK
(x7) | 8x1



H100806 | SCREW POH BLK
(x13) | 8/32x1 1/8



H100804 | T-NUT
(x13) | 8/32



H100458 | LAG SCREW WH BLK
(x26) | 5/16x2



H100403 | LAG SCREW WH BLK
(x11) | 1/4x1 1/2



H100198 | WASHER LOCK EXT BLK
(x61) | 8x19

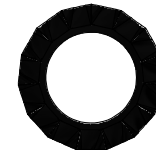

H100199 | WASHER LOCK EXT BLK
(x8) | 12x19



H100405 | WASHER LOCK EXT BLK
(x17) | 6x15



H100400 | WASHER LOCK EXT BLK
(x4) | 8x15

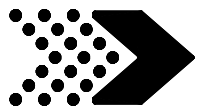

Accessory Components (Not to Scale)

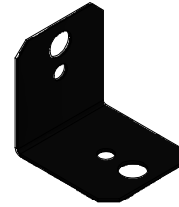

A4M00555 | 90° L-BRACKET - BLK
(x8)

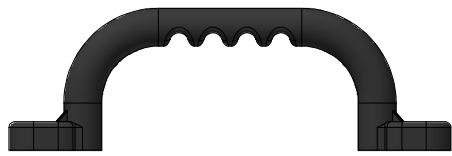

A100028 | HAND GRIP GREEN PLASTIC
(x2)



A4M00528 | BYD ID TAG (MEDIUM) AGES 2 TO 10
(x1)

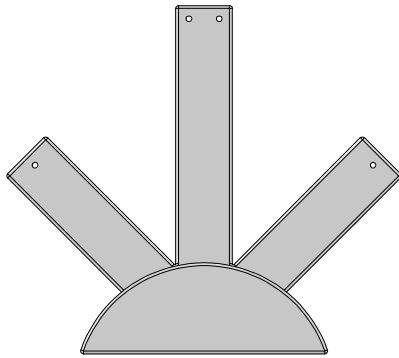

A100361 | PLASTIC SUNBURST
(x2)

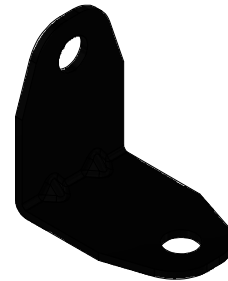

A4M01047 | L BRACKET 2.5x38x55x55
(x3)

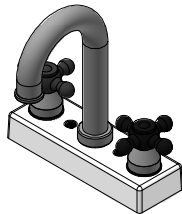

A6P00024 | FAUCET KIT
(x1)



A6P00067 | KNOB - BLK
(x1)

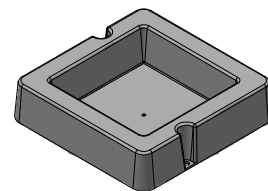

A6P00032 | SURFACE MOUNT BASIN
(x1)



A100178 | AUGER GROUND STAKE
(x4)



Accessory Components (Not to Scale)

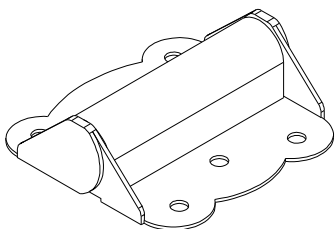

A4M00624 | HINGE (DOOR, SPRING LOADED)
(x1)

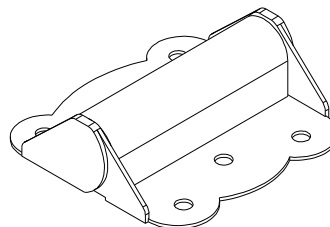

A4M00994 | HINGE (DOOR, NON-SPRING LOADED)
(x1)



A4M00933 | DOOR STOP
(x1)



A4M01045 | BELL ASSEMBLY
(x1)

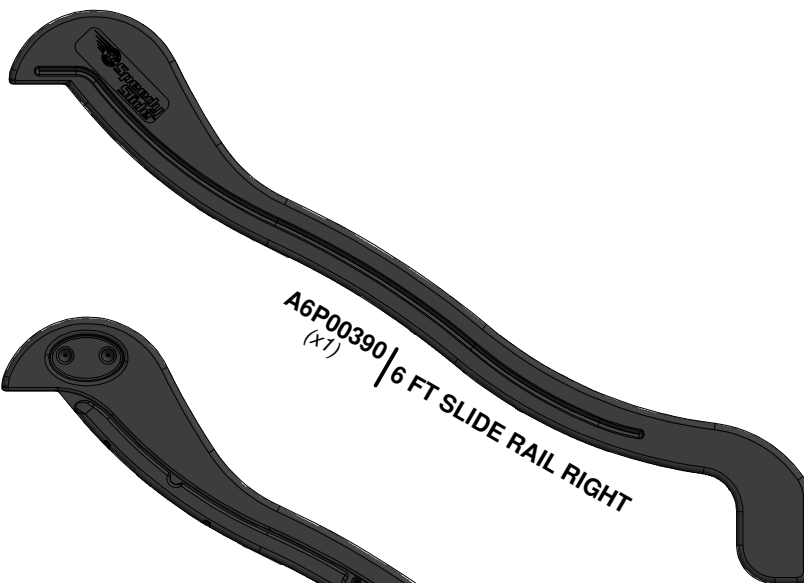

A6P00390 | 6 FT SLIDE RAIL RIGHT
(x1)

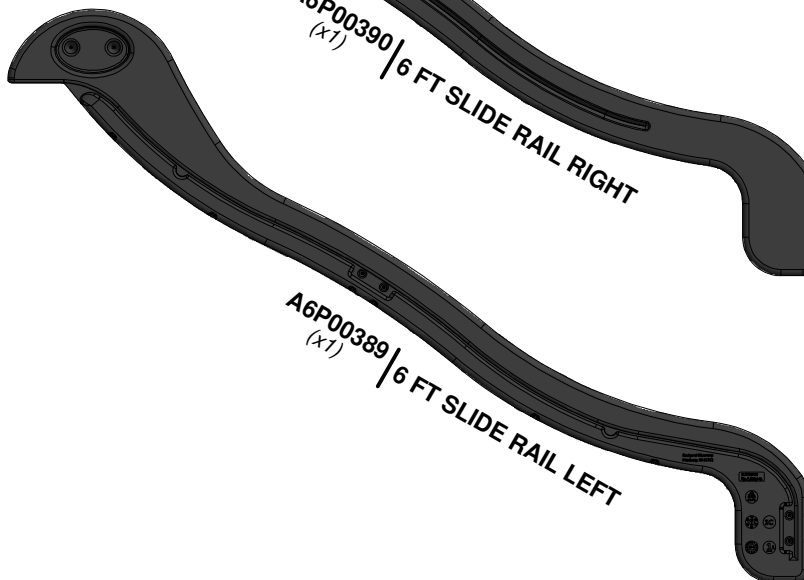

A6P00389 | 6 FT SLIDE RAIL LEFT
(x1)



A6P00391 | 6 FT SLIDE BED
(x1)



Accessory Components (Not to Scale)

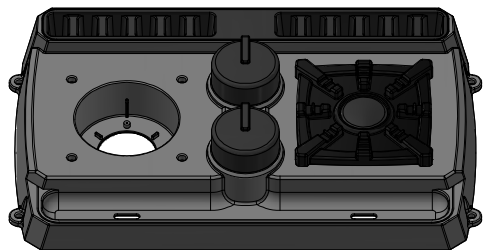

A6P00335 | STOVE BASE
(x1)

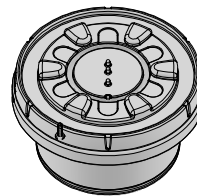

A6P00330 | INDUCTIVE BURNER KIT
(x1)



A6P00331 | BLENDER
(x1)

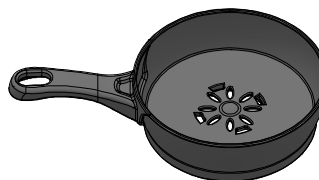

A6P00338 | FRY PAN
(x1)

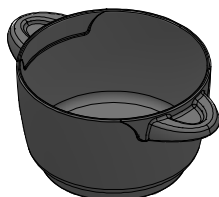

A6P00336 | BOIL POT
(x1)

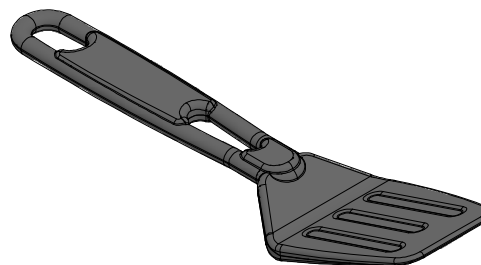

A6P00339 | SPATULA
(x1)

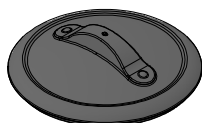

A6P00337 | POT/PAN LID
(x2)

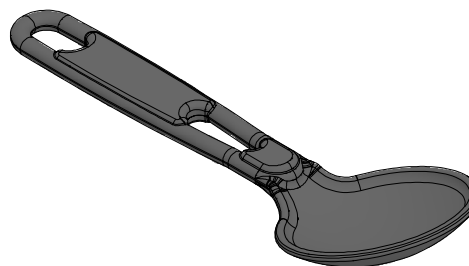

A6P00340 | LADLE
(x1)



SLIDE ASSEMBLY

STEP 1



A6P00391 | 6 FT SLIDE BED
(1)



M77 | SLIDE BRACE - W4L13297
(1) | 5/8"x3 3/8"x14 1/4" (16x86x362)



H100396 | BOLT WH BLK
(2) | 5/16x1/2



H100379 | T-NUT BLK
(2) | 5/16

PLACE 'M77' SLIDE BRACE BOARD 1/2" FROM THE BOTTOM EDGE OF THE SLIDE BED. USING THE BOARD AS A TEMPLATE, MARK WHERE THE PILOT HOLES WILL BE DRILLED. USE A 3/8" DRILL BIT TO DRILL THE PILOT HOLES INTO THE SLIDE BED. ATTACH THE SLIDE BED SUPPORT BOARD USING THE HARDWARE PROVIDED.



TIP: PRE-BENDING THE ENDS WILL EASE ASSEMBLY. PLACING THE SLIDE BED OUT IN THE SUN MAKES IT EASIER TO BEND.

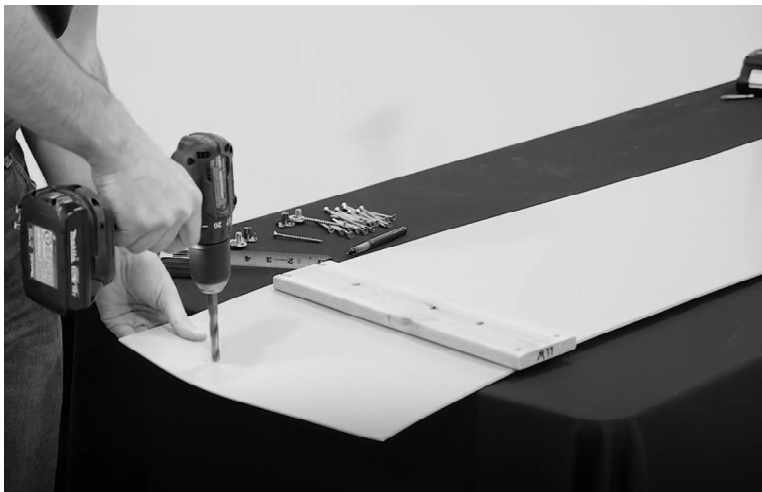
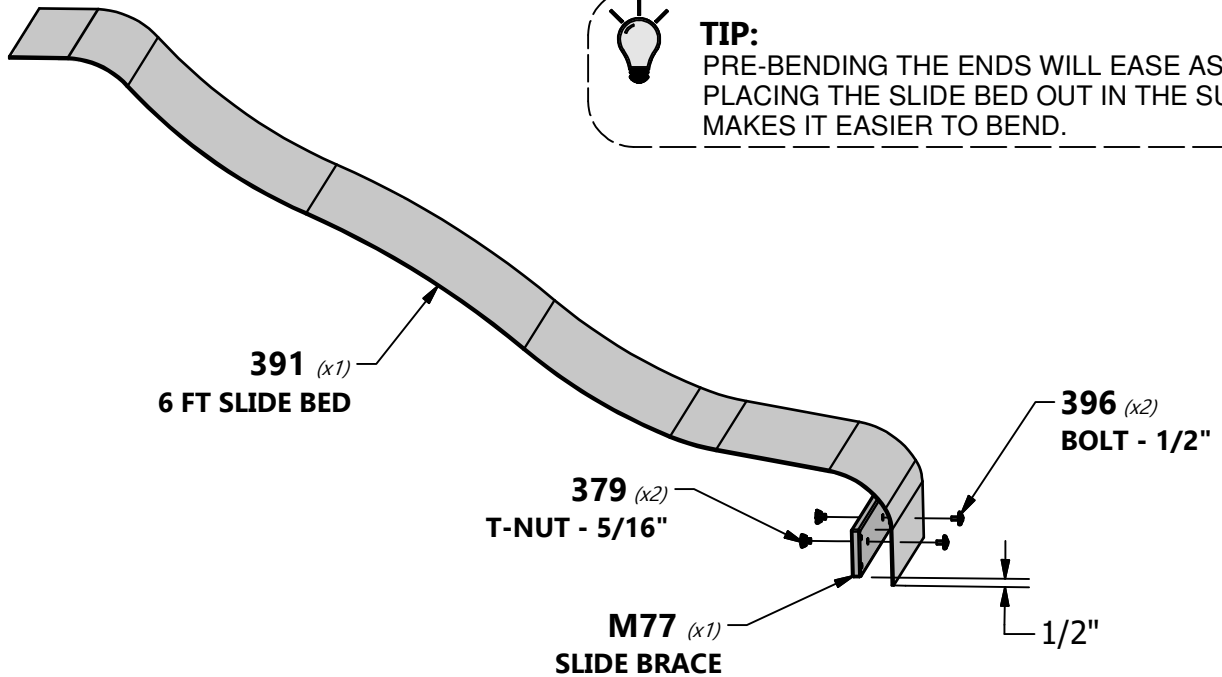



SLIDE ASSEMBLY

STEP 2

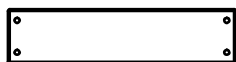

M78 | SLIDE BRACE - W4L13298
(1) 5/8"x3 3/8"x14 1/4" (16x86x362)



A6P00390 | 6 FT SLIDE RAIL RIGHT
(1)



A6P00389 | 6 FT SLIDE RAIL LEFT
(1)



H100201 | SCREW PFH BLK
(16) 8x2-1/2



NOTE:

1. PLACE THE SLIDE RAIL ON FLAT SURFACE. STARTING AT THE BOTTOM, INSERT THE SLIDE BED INTO THE CHANNEL ON THE INSIDE OF THE RAIL. HOLD THE SLIDE BED IN PLACE WHILE A HELPER BENDS THE SLIDE BED INTO THE CHANNEL. MAKE SURE THE SLIDE BED IS COMPLETELY INSERTED INTO THE CHANNEL. SEE VIEWING WINDOW BELOW.
2. INSERT THE TWO CENTER SLIDE BRACES INTO THEIR RESPECTIVE LOCATIONS.
3. USE A 1/8" DRILL BIT, DRILL PILOT HOLES IN EACH INDENTATION ALONG EACH SIDE RAIL. THERE SHOULD BE 12 INDENTATIONS ON EACH RAIL. BE SURE TO DRILL THROUGH THE SLIDE RAIL AND THE SLIDE BED. THEN SECURE WITH THE PROVIDED HARDWARE.

REPEAT THIS PROCESS FOR THE OPPOSITE SLIDE RAIL.



TIP:

A HELPER IS REQUIRED FOR THIS STEP.



FAILURE TO INSERT SLIDE BED COMPLETELY AND SECURED BY SCREWS MAY RESULT IN INJURY OR AMPUTATION. EXPOSED SLIDE EDGES CAN BE SHARP AND BECOME A LACERATION HAZARD IF THE SLIDE IS NOT PROPERLY ASSEMBLED.

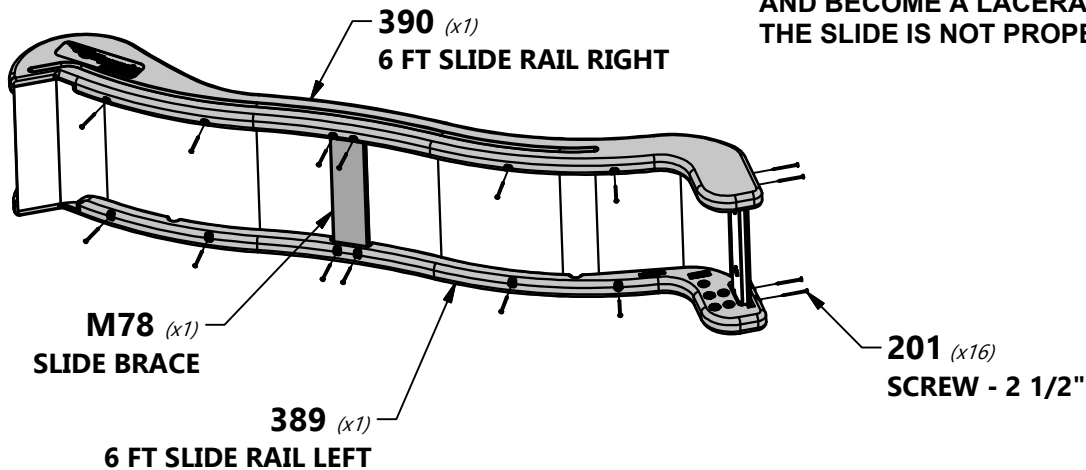

VIEWING WINDOW



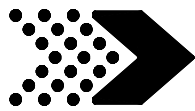

LADDER ASSEMBLY

STEP 1

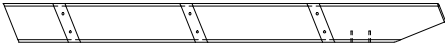

H79 | LEFT UPRIGHT - W4L14900
(x1) | 1"x3 3/8"x38 3/8" (24x86x976)



H76 | LADDER RUNG - W4L14899
(x3) | 1"x3 3/8"x18 1/8" (24x86x460)



H100391 | SCREW PFH BLK
(x6) | 8x2

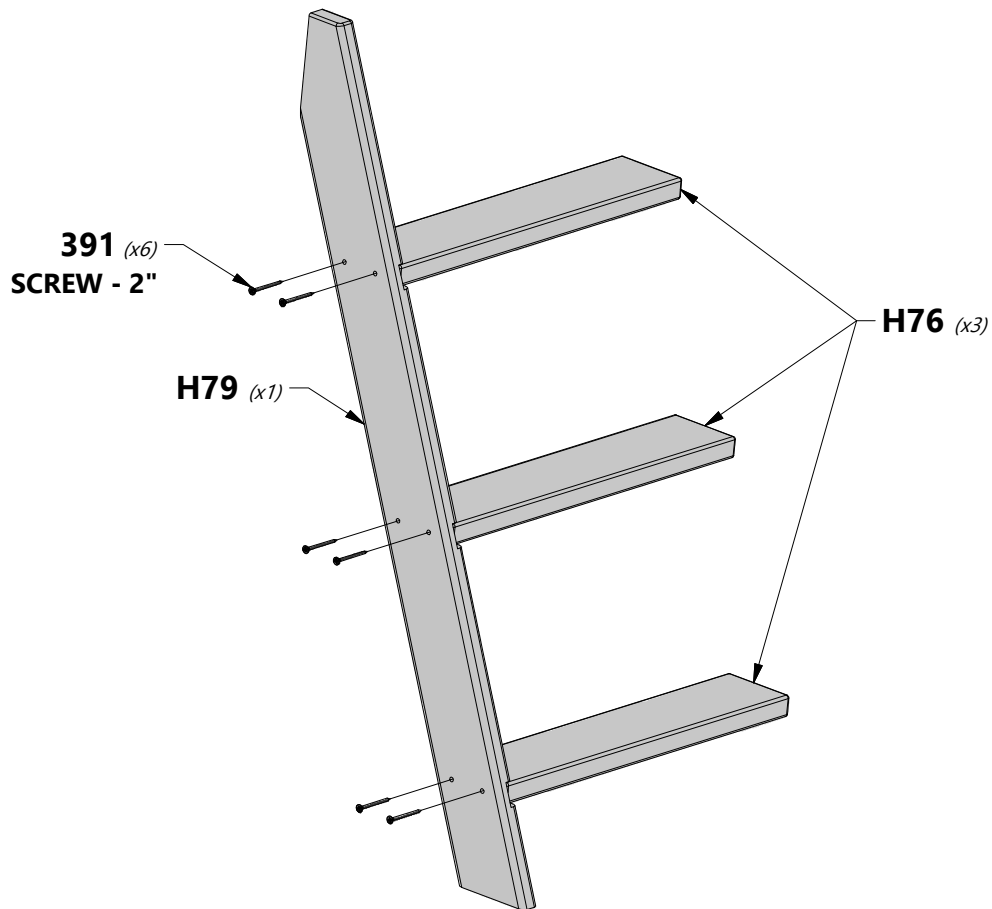

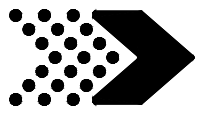

LADDER ASSEMBLY

STEP 2

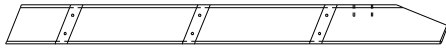

H80 | RIGHT UPRIGHT - W4L14901
(x1) | 1"x3 3/8"x38 3/8" (24x86x976)



H100391 | SCREW PFH BLK
(x6) | 8x2

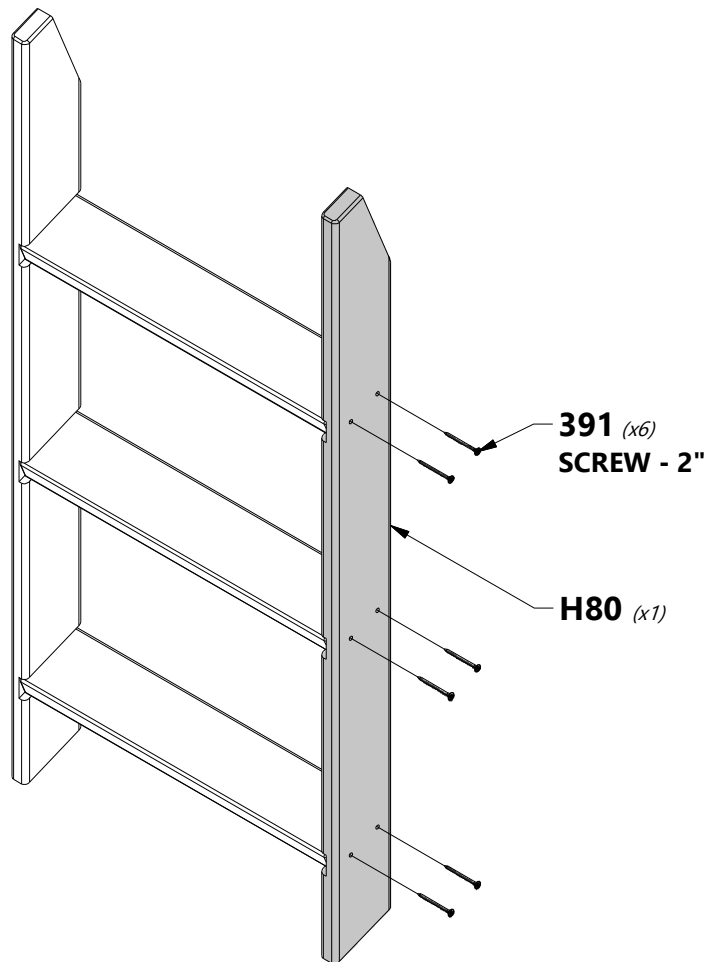

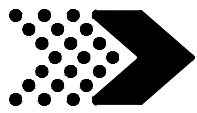

M73 | REAR SUPPORT - W4L14913
(x1) | 5/8"x3 3/8"x19 1/4" (16x86x488)



H100391 | SCREW PFH BLK
(x4) | 8x2

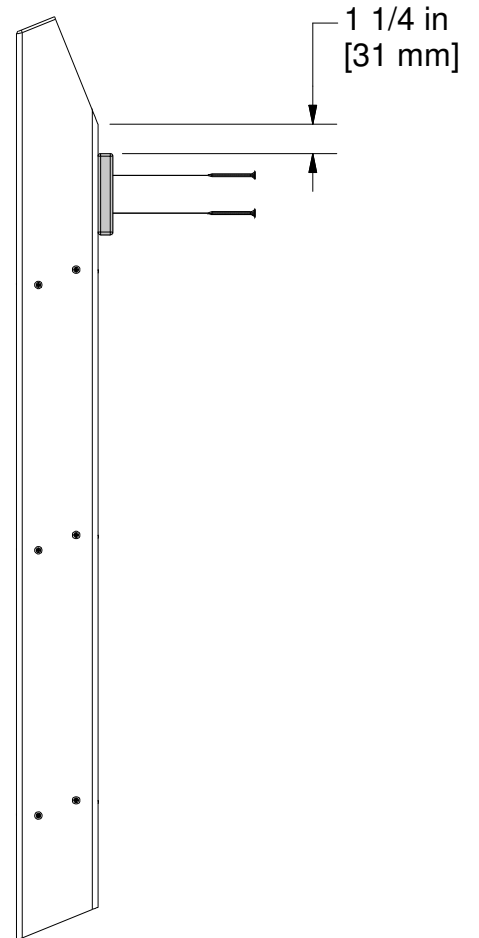
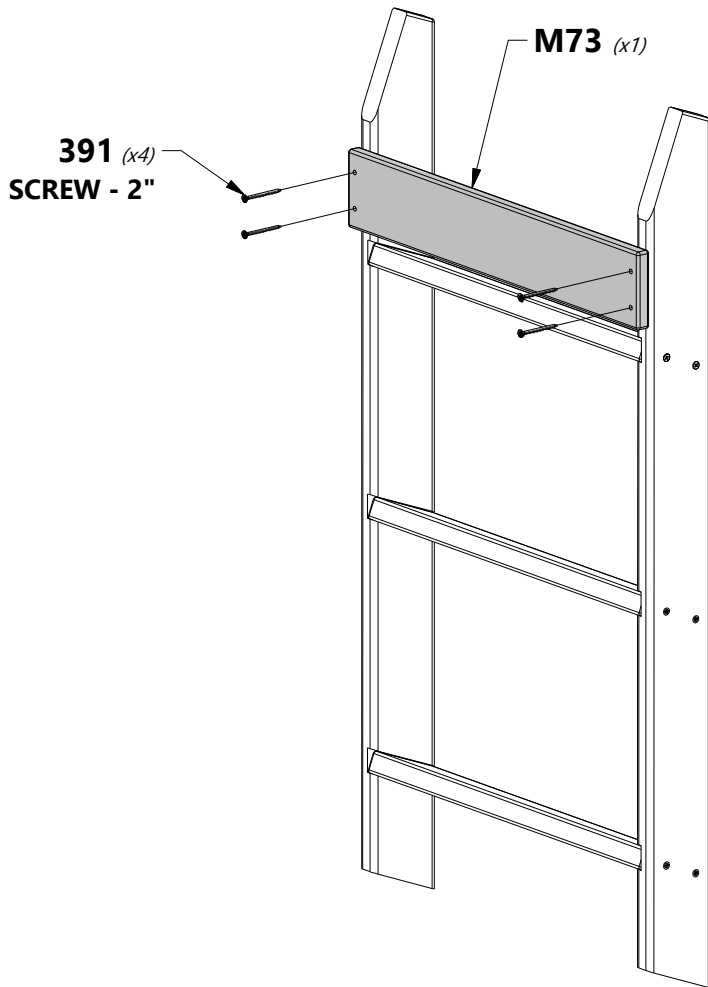

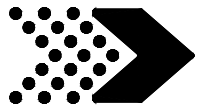

H110 | ATTACHMENT BOARD - W4L14914
(x1) | 1"x3 3/8"x19 1/4" (24x86x488)



H100391 | SCREW PFH BLK
(x4) | 8x2

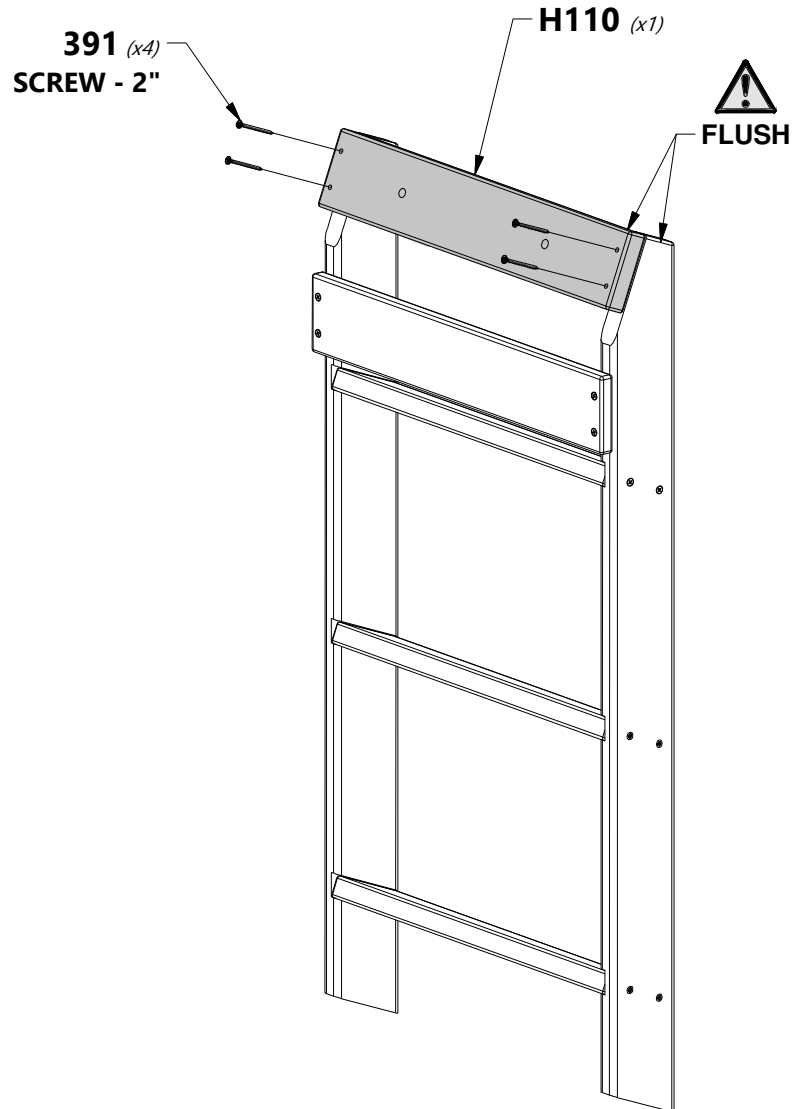

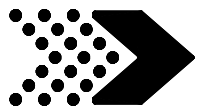

DECK ASSEMBLY

STEP 1

E1 LEFT FRONT UPRIGHT - W4L14880
(x1) | 1 3/8"x3 3/8"x62 3/8" (36x86x1584)

H2 FLOOR RAIL - W4L14889
(x1) | 1"x3 3/8"x54 7/8" (24x86x1394)

J1 FLOOR SUPPORT BLOCK - W4L14902
(x1) | 1"x3 3/8"x3 3/8" (24x86x86)

E4 LEFT REAR UPRIGHT - W4L14883
(x1) | 1 3/8"x3 3/8"x35" (36x86x889)

G2 GROUND BOARD - W4L14885
(x1) | 1"x5 1/4"x54 7/8" (24x134x1394)



H100484 BOLT WH BLK
(x1) | 5/16x3 1/4



H100205 BOLT WH BLK
(x5) | 5/16x2-1/4



H100483 SCREW PFH BLK
(x1) | 8x2 1/4



H100198 WASHER LOCK EXT BLK
(x6) | 8x19



H100379 T-NUT BLK
(x6) | 5/16



NOTE:

WE RECOMMEND THAT YOU INSTALL ALL "T-NUTS" FIRST, WHEN A "T-NUT" IS REQUIRED, THROUGHOUT THE ASSEMBLY PROCESS.

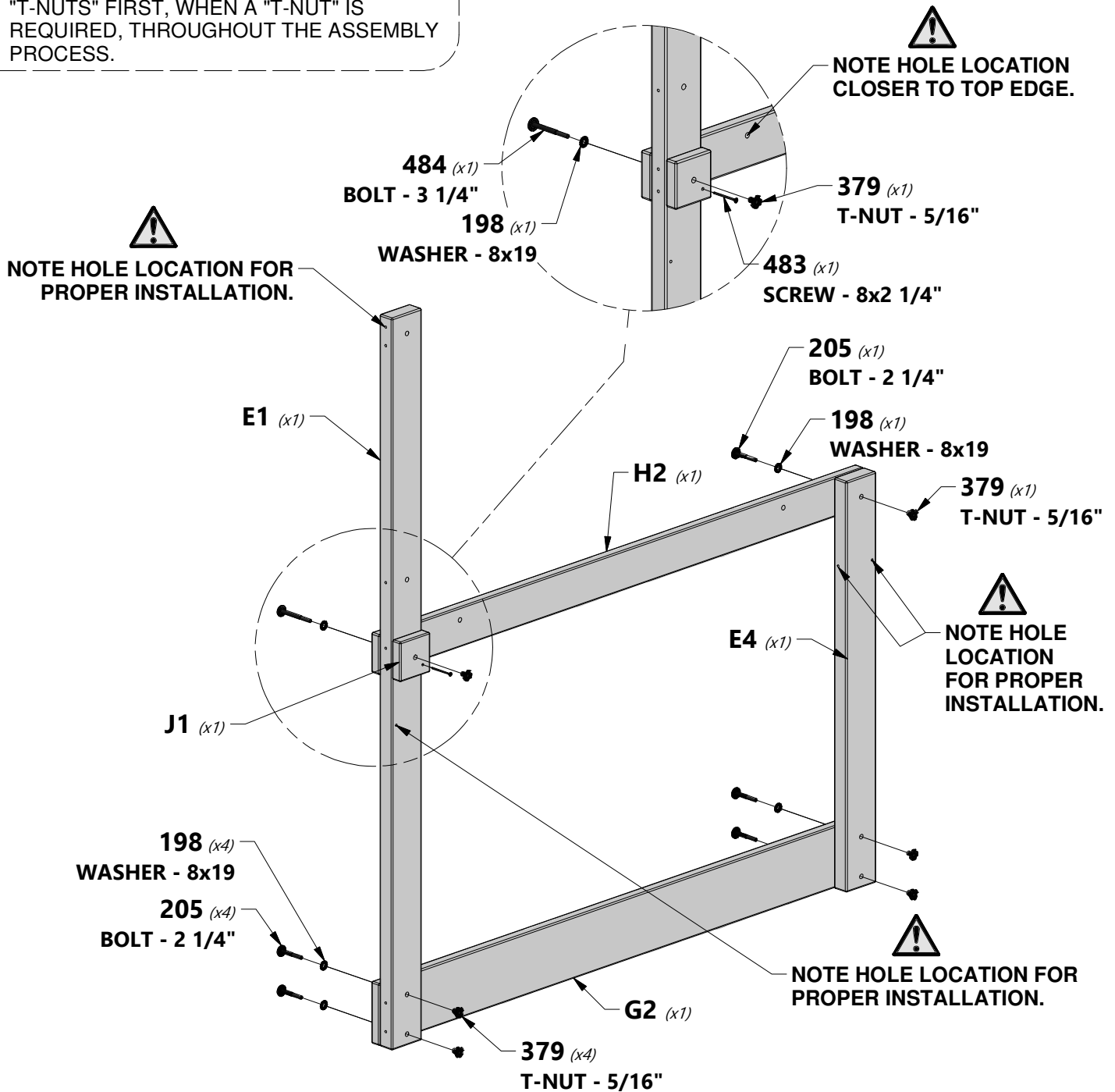

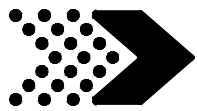

G1 | **GROUND BOARD - W4L14884**
(x2) | 1"x5 1/4"x56 3/4" (24x134x1442)



H100458 | **LAG SCREW WH BLK**
(x4) | 5/16x2



H100198 | **WASHER LOCK EXT BLK**
(x4) | 8x19

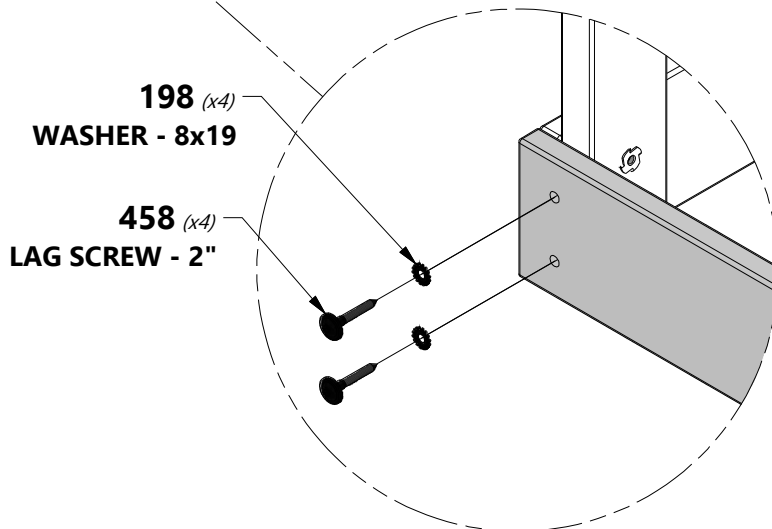
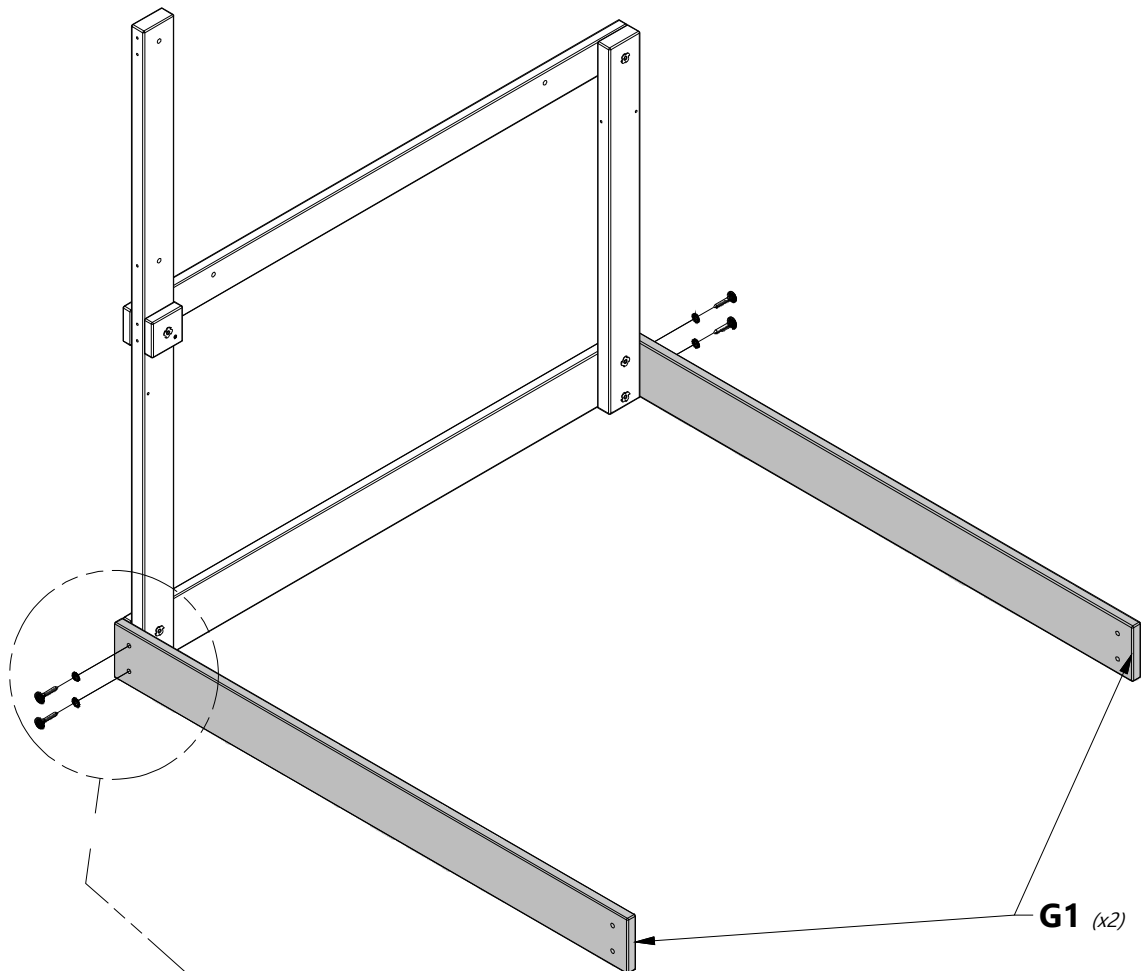

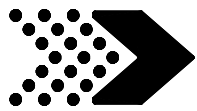

DECK ASSEMBLY

STEP 3

E2 | RIGHT FRONT UPRIGHT - W2A03763
(x1) | 1 3/8"x3 3/8"x62 3/8" (36x86x1584)

H4 | FLOOR RAIL - W4L14891
(x1) | 1"x3 3/8"x54 7/8" (24x86x1394)

J1 | FLOOR SUPPORT BLOCK - W4L14902
(x2) | 1"x3 3/8"x3 3/8" (24x86x86)

E3 | RIGHT REAR UPRIGHT - W4L14882
(x1) | 1 3/8"x3 3/8"x62 3/8" (36x86x1584)

G2 | GROUND BOARD - W4L14885
(x1) | 1"x5 1/4"x54 7/8" (24x134x1394)



H100484 | BOLT WH BLK
(x2) | 5/16x3 1/4



H100205 | BOLT WH BLK
(x4) | 5/16x2-1/4



H100483 | SCREW PFH BLK
(x2) | 8x2 1/4



H100198 | WASHER LOCK EXT BLK
(x6) | 8x19



H100379 | T-NUT BLK
(x8) | 5/16

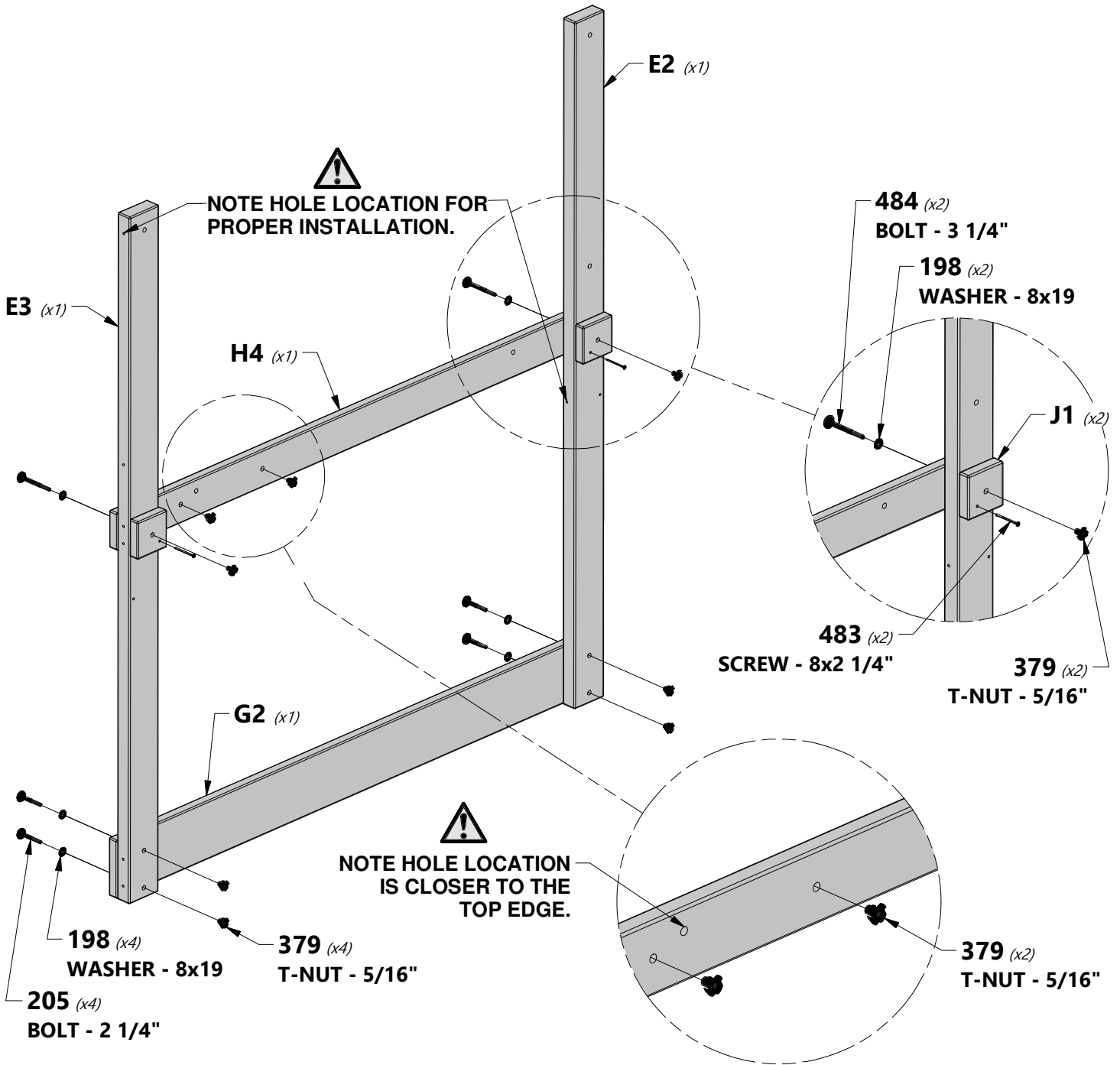

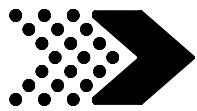

H100458 | LAG SCREW WH BLK
(x4) | 5/16x2



H100198 | WASHER LOCK EXT BLK
(x4) | 8x19

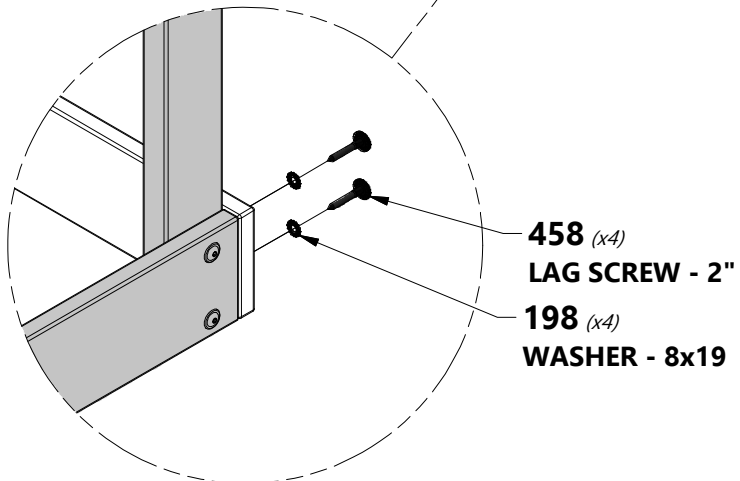
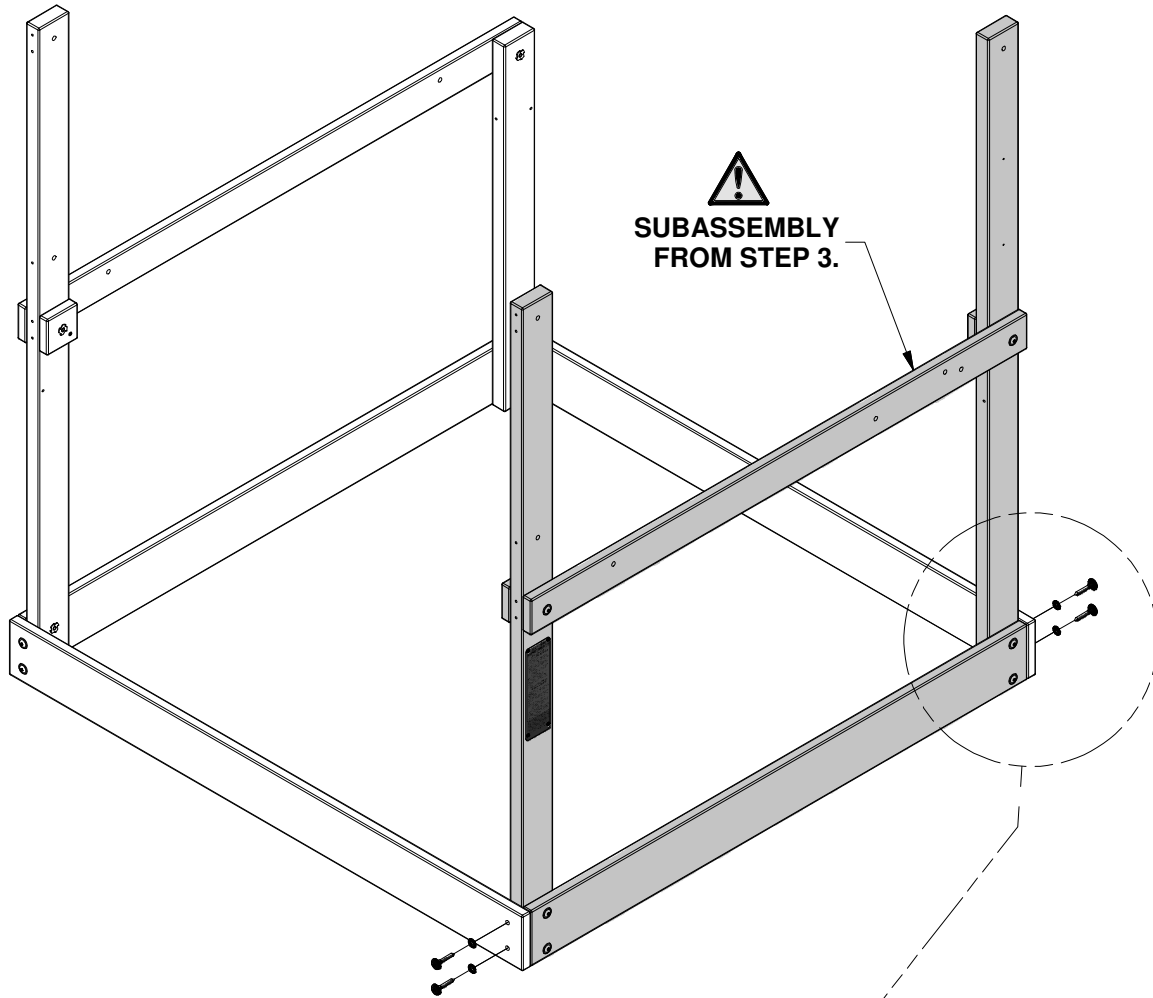

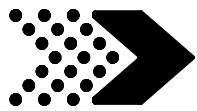

DECK ASSEMBLY

STEP 5

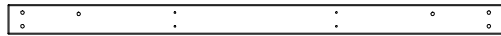

H1 | FLOOR RAIL - W4L14888
(x1) | 1"x3 3/8"x56 3/4" (24x86x1442)



H100458 | LAG SCREW WH BLK
(x4) | 5/16x2



H100198 | WASHER LOCK EXT BLK
(x4) | 8x19



NOTE HOLE LOCATION IS CLOSER TO THE TOP EDGE.

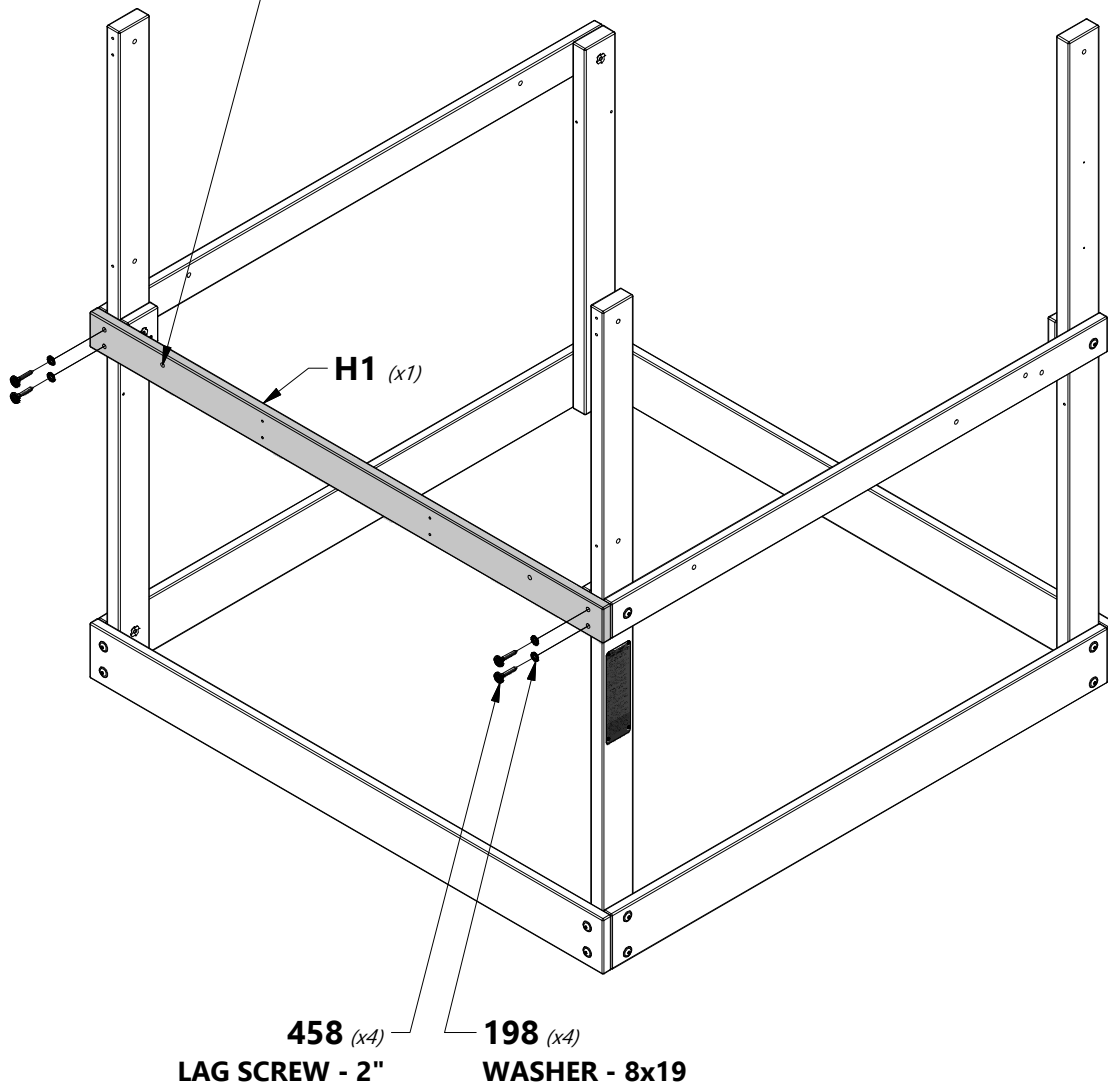

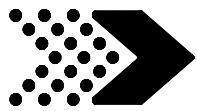

DECK ASSEMBLY

STEP 6



H1 | FLOOR RAIL - W4L14888
(x1) | 1"x3 3/8"x56 3/4" (24x86x1442)



H100458 | LAG SCREW WH BLK
(x4) | 5/16x2



H100198 | WASHER LOCK EXT BLK
(x4) | 8x19

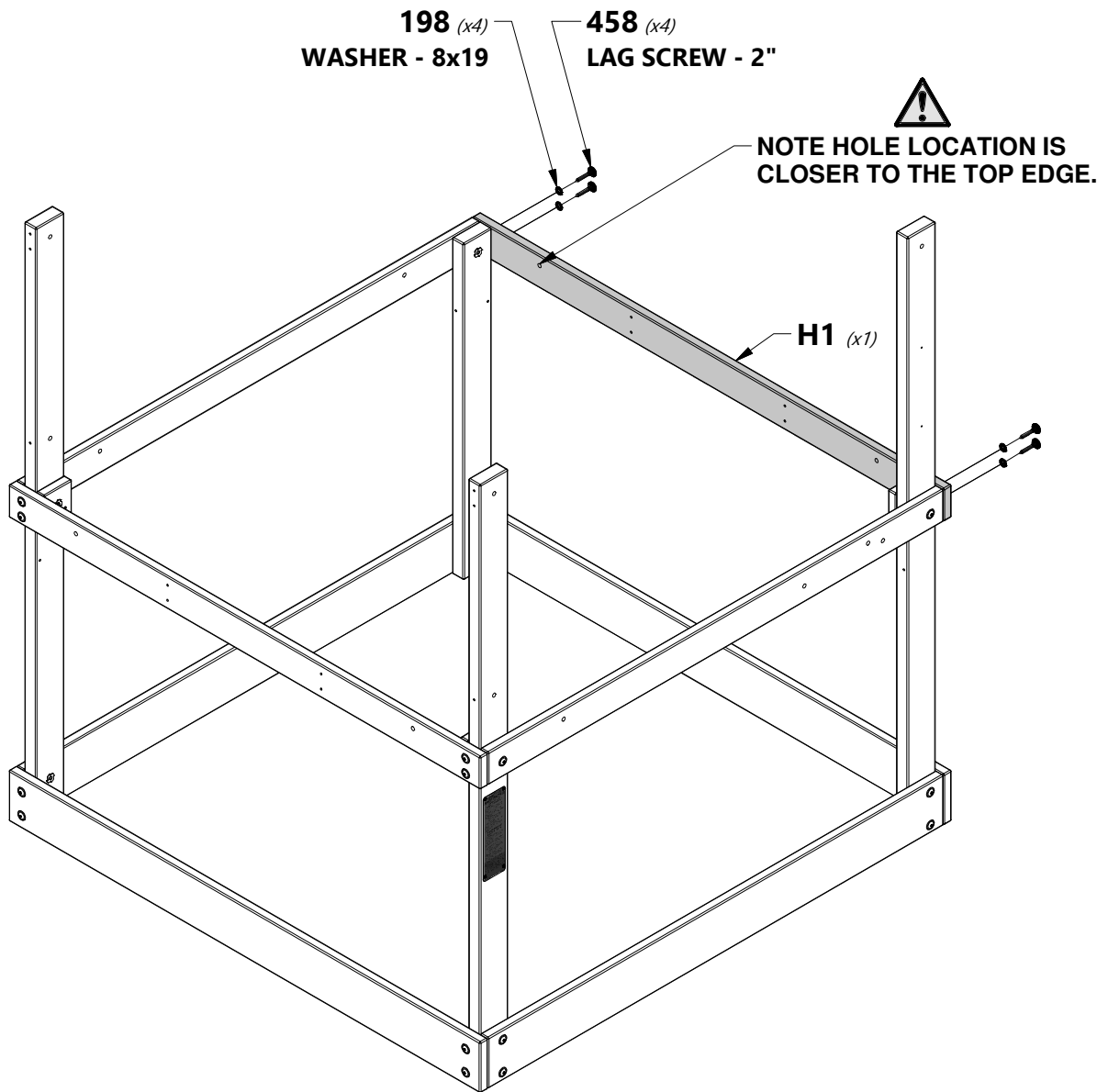

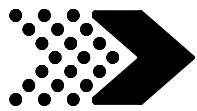

DECK ASSEMBLY

STEP 7



H20 | DECK BRACE - W4L14898
(x8) | 1"x3 3/8"x13" (24x86x330)



H100378 | BOLT WH BLK
(x8) | 5/16x1 3/4



H100198 | WASHER LOCK EXT BLK
(x8) | 8x19



H100403 | LAG SCREW WH BLK
(x8) | 1/4x1 1/2



H100405 | WASHER LOCK EXT BLK
(x8) | 6x15



H100379 | T-NUT BLK
(x8) | 5/16

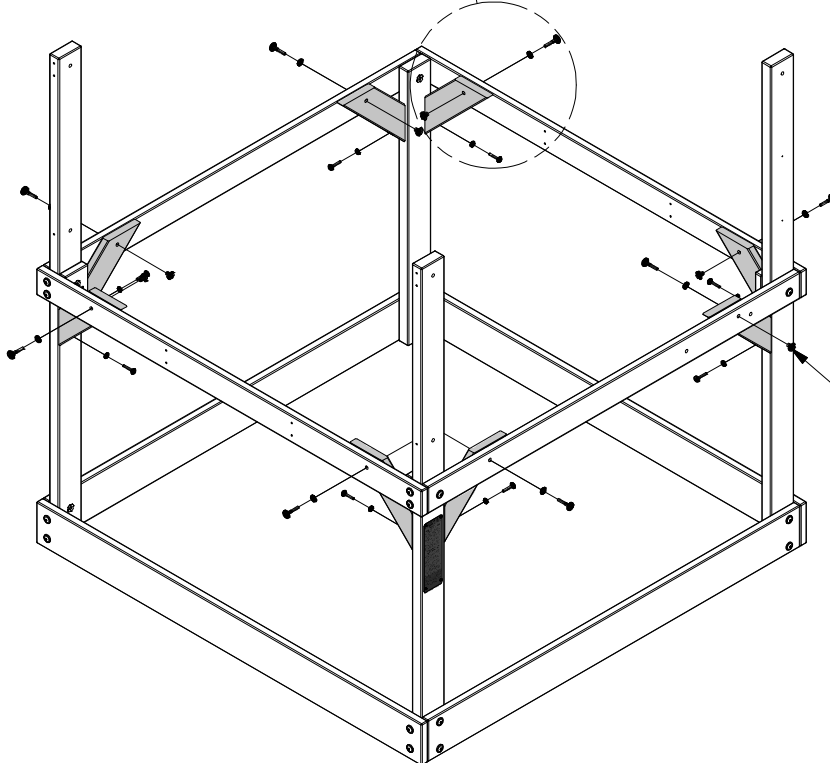
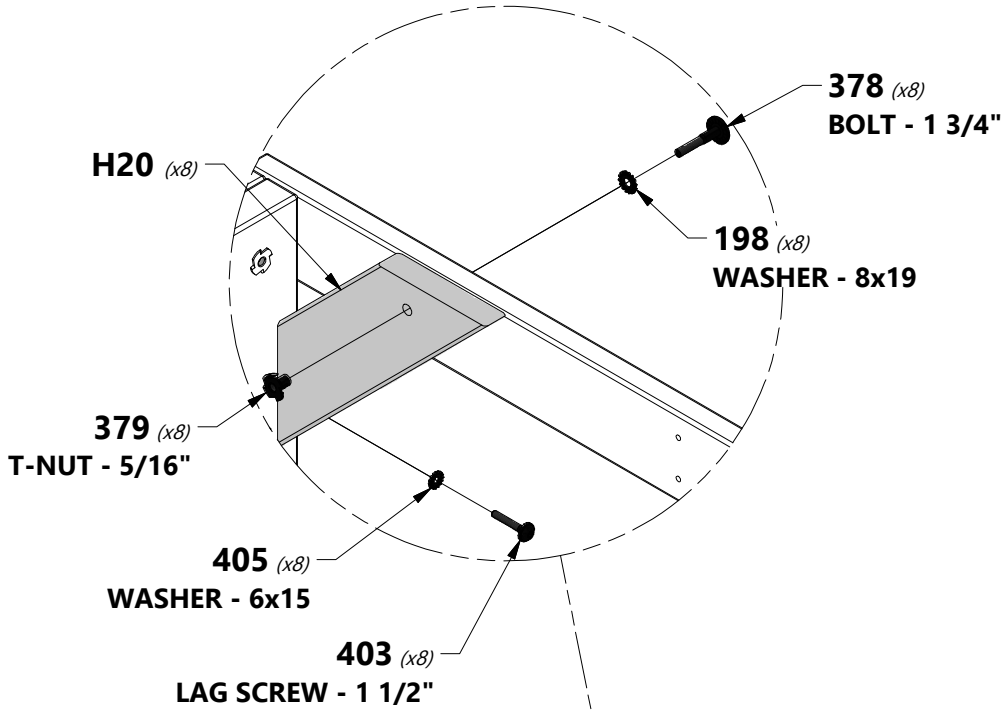

NOTE T-NUT OUTWARD THIS LOCATION ONLY.

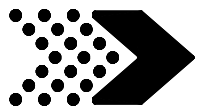

H5 | FLOOR SUPPORT - W4L14892
(x2) | 1"x3 3/8"x54 7/8" (24x86x1394)



H100201 | SCREW PFH BLK
(x8) | 8x2-1/2"

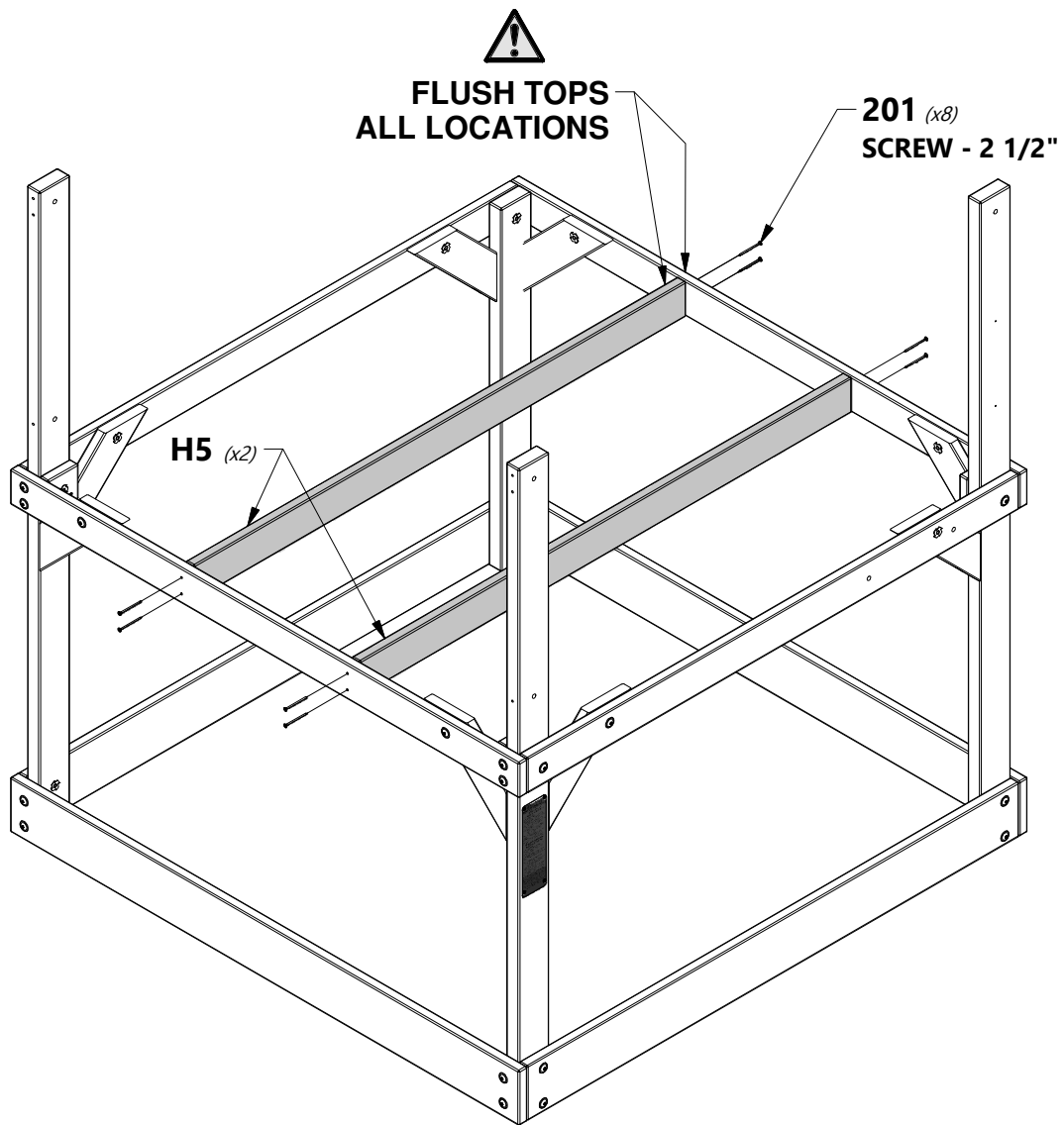

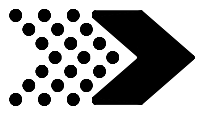

DECK ASSEMBLY

STEP 9



L1 | FLOOR BOARD - W4L14904
(x1) | 5/8"x4 3/8"x52" (16x112x1321)

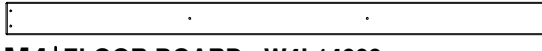

M4 | FLOOR BOARD - W4L14909
(x13) | 5/8"x3 3/8"x56 3/4" (16x86x1442)



L2 | FLOOR BOARD - W4L14905
(x1) | 5/8"x4 3/8"x54 3/8" (16x112x1382)



M6 | FLOOR BOARD - W4L14886
(x1) | 5/8"x3 3/8"x56 3/4" (16x86x1442)



H100200 | SCREW PFH BLK
(x96) | 8x1 1/2"



NOTE:

ALL FLOOR BOARDS SHOULD BE SPACED EVENLY.

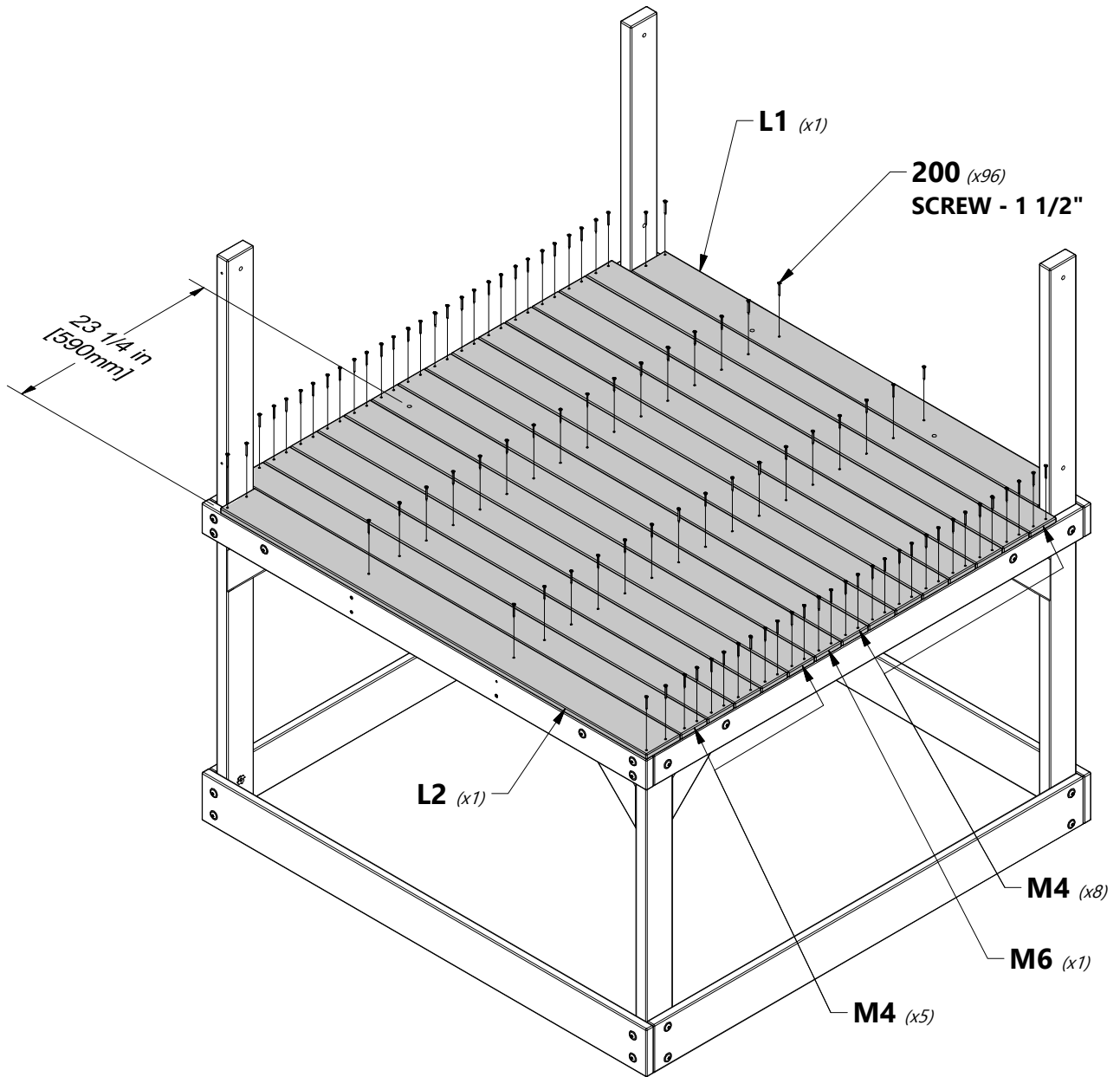

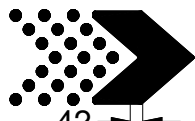

DECK ASSEMBLY

STEP 10

42 ← → 43

H6 | WALL RAIL - W4L14893
(x2) | 1"x3 3/8"x18 1/2" (24x86x469)

H7 | WALL RAIL - W4L14894
(x1) | 1"x3 3/8"x56 3/4" (24x86x1442)

H8 | WALL RAIL - W4L14895
(x1) | 1"x3 3/8"x34 1/4" (24x86x871)



H11 | WALL RAIL - W4L14923
(x1) | 1"x3 3/8"x55 7/8" (24x86x1418)

M7 | WALL BOARD - W4L14887
(x2) | 5/8"x3 3/8"x26 1/2" (16x86x673)

A4M01047 | L BRACKET 2.5x38x55x55
(x2)



H100458 | LAG SCREW WH BLK
(x6) | 5/16x2



H100198 | WASHER LOCK EXT BLK
(x13) | 8x19



H100205 | BOLT WH BLK
(x3) | 5/16x2-1/4



H100199 | WASHER LOCK EXT BLK
(x2) | 12x19



H100407 | BOLT WH BLK
(x4) | 5/16x1 1/2



H100469 | NUT BARREL WH BLK
(x2) | 5/16x5/8



H100396 | BOLT WH BLK
(x4) | 5/16x1/2



H100379 | T-NUT BLK
(x9) | 5/16

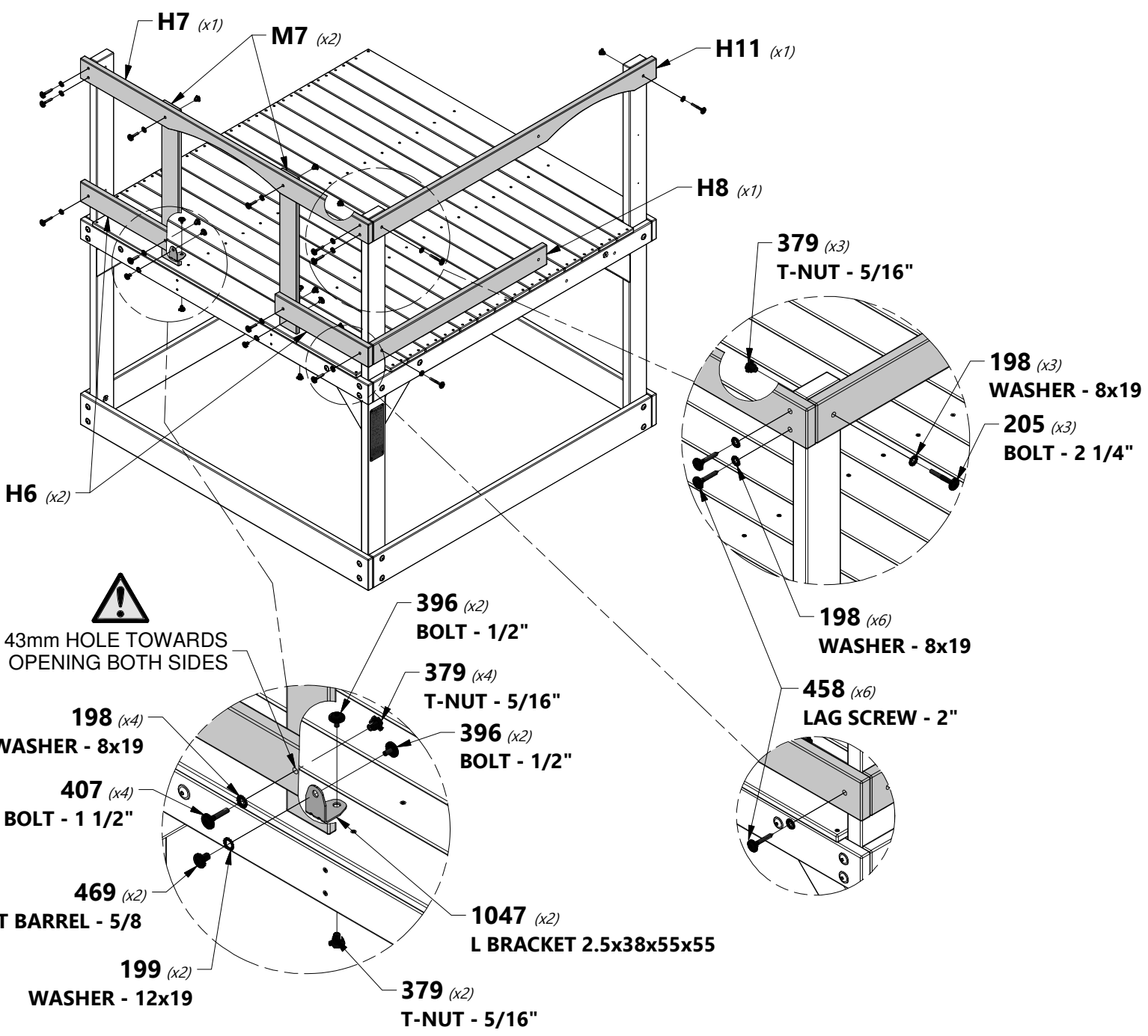

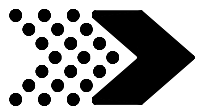

DECK ASSEMBLY

STEP 11

M10 | WALL BOARD - W4L14911
(x1) | 5/8"x3 3/8"x26 1/2" (16x86x673)



A4M01047 | L BRACKET 2.5x38x55x55
(x1)

A100028 | HAND GRIP GREEN PLASTIC
(x2)



H100469 | NUT BARREL WH BLK
(x1) | 5/16x5/8



H100398 | T-NUT BLK
(x2) | 1/4



H100403 | LAG SCREW WH BLK
(x2) | 1/4x1 1/2



H100171 | BOLT WH BLK
(x2) | 1/4x1



H100198 | WASHER LOCK EXT BLK
(x2) | 8x19



H100407 | BOLT WH BLK
(x2) | 5/16x1 1/2



H100405 | WASHER LOCK EXT BLK
(x4) | 6x15



H100396 | BOLT WH BLK
(x2) | 5/16x1/2



H100379 | T-NUT BLK
(x3) | 5/16

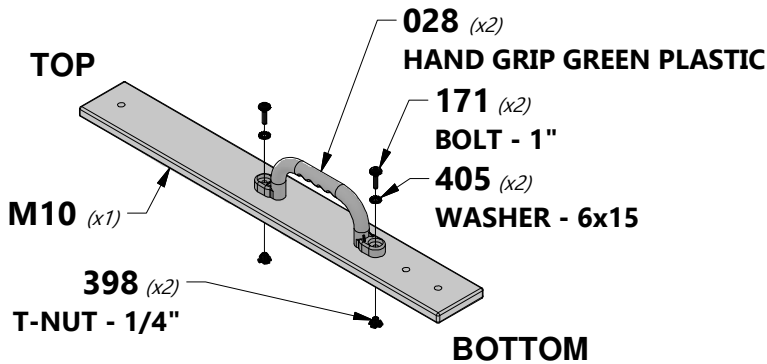

NOTE:
ASSEMBLE HAND GRIP TO 'M10'
BOARD FIRST.

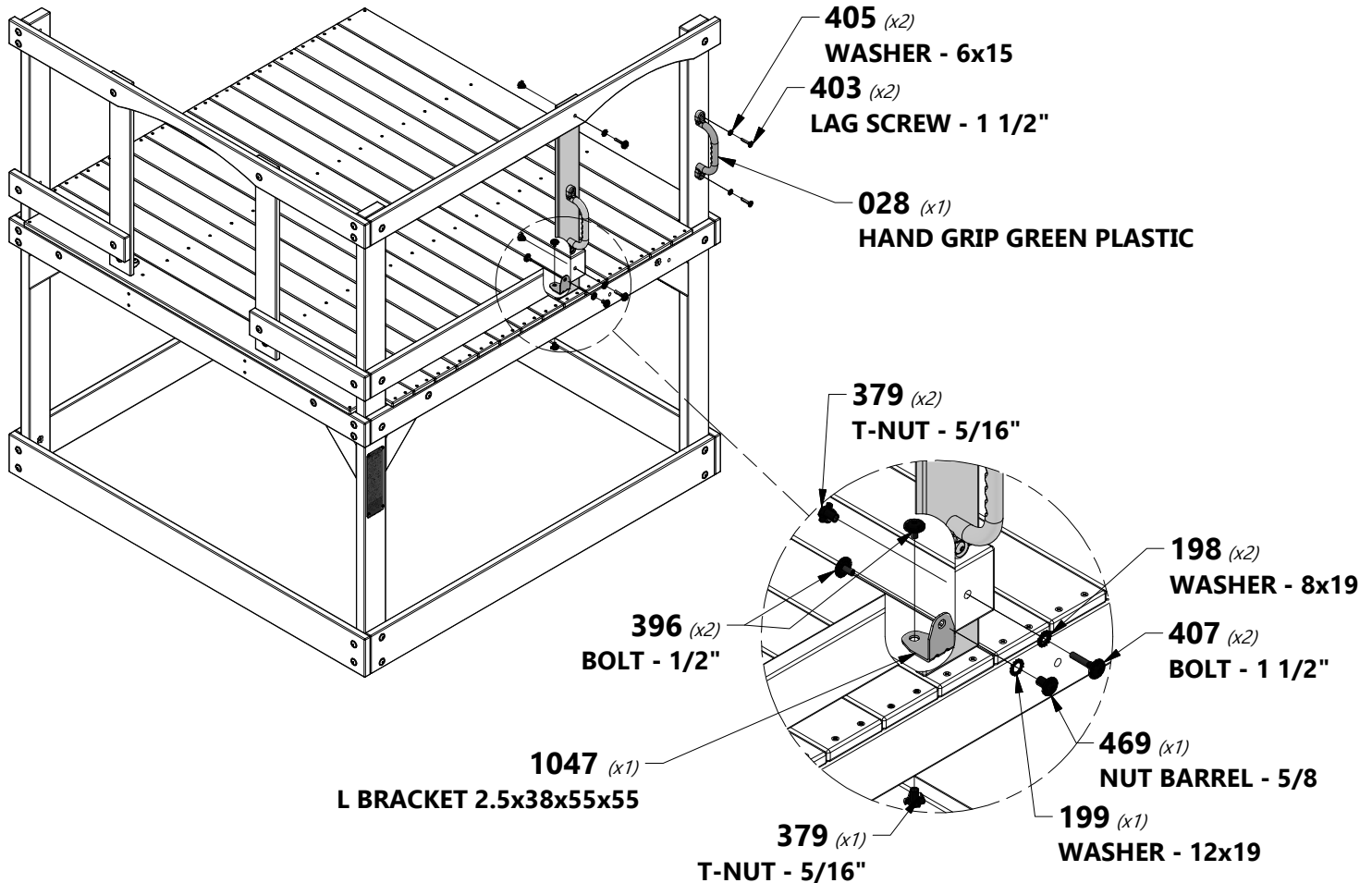

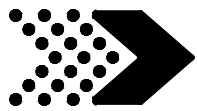

DECK ASSEMBLY

STEP 12

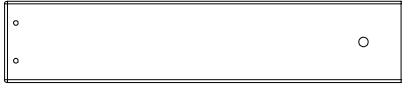

H9 | WALL RAIL - W4L14896
(x2) | 1"x3 3/8"x16 5/8" (24x86x423)

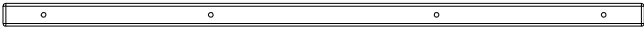

S1 | RAIL BOARD - W4L14920
(x1) | 1"x1"x26 3/4" (24x24x679)



H100205 | BOLT WH BLK
(x2) | 5/16x2-1/4



H100198 | WASHER LOCK EXT BLK
(x2) | 8x19



H100200 | SCREW PFH BLK
(x4) | 8x1 1/2



H100379 | T-NUT BLK
(x2) | 5/16

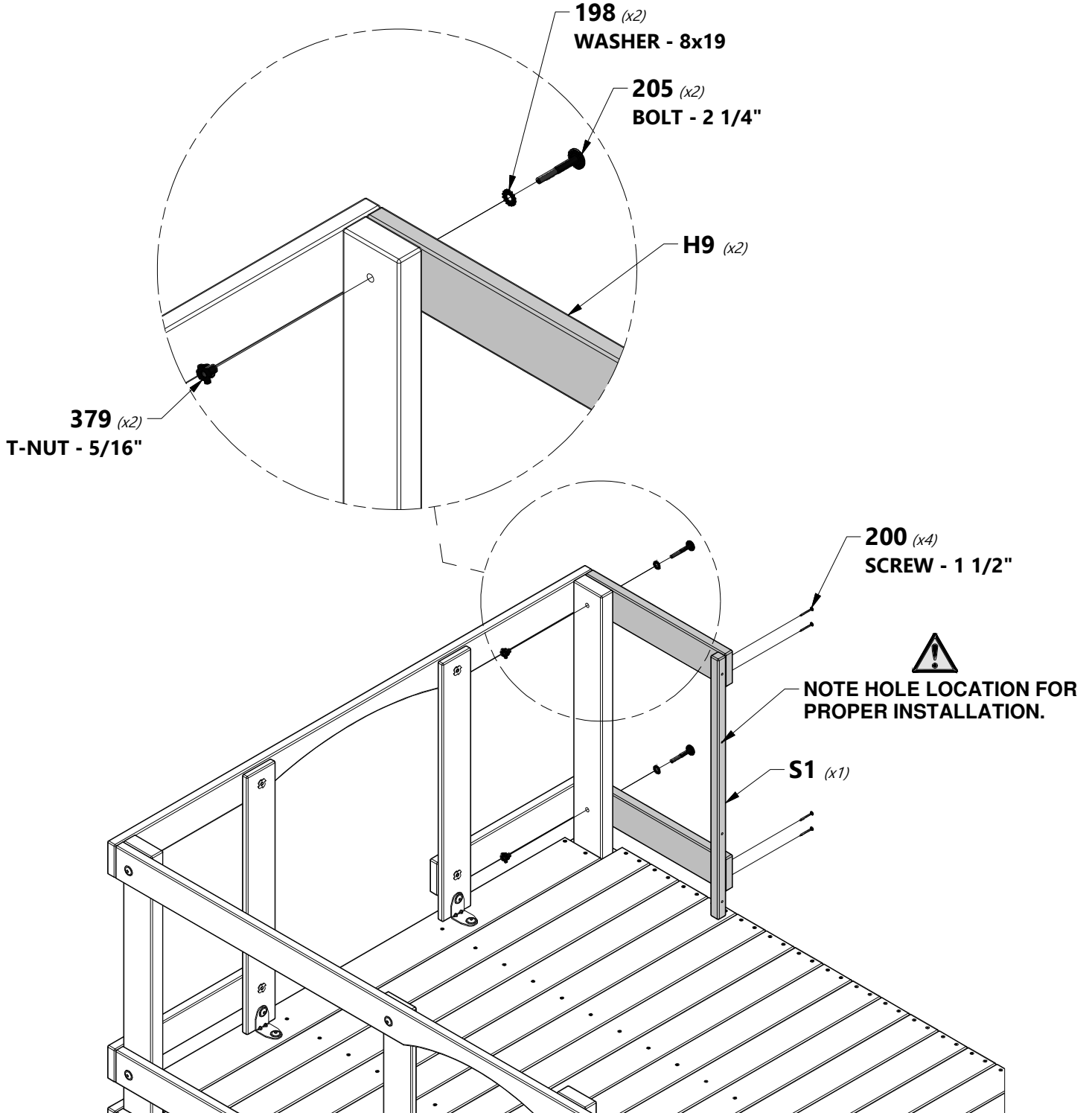

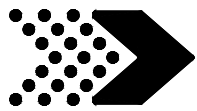

H10 | WALL RAIL - W4L14897
(x2) | 1"x3 3/8"x16 3/4" (24x86x426)

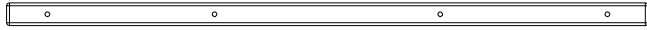

S1 | RAIL BOARD - W4L14920
(x1) | 1"x1"x26 3/4" (24x24x679)



H100458 | LAG SCREW WH BLK
(x2) | 5/16x2



H100198 | WASHER LOCK EXT BLK
(x2) | 8x19



H100200 | SCREW PFH BLK
(x4) | 8x1 1/2

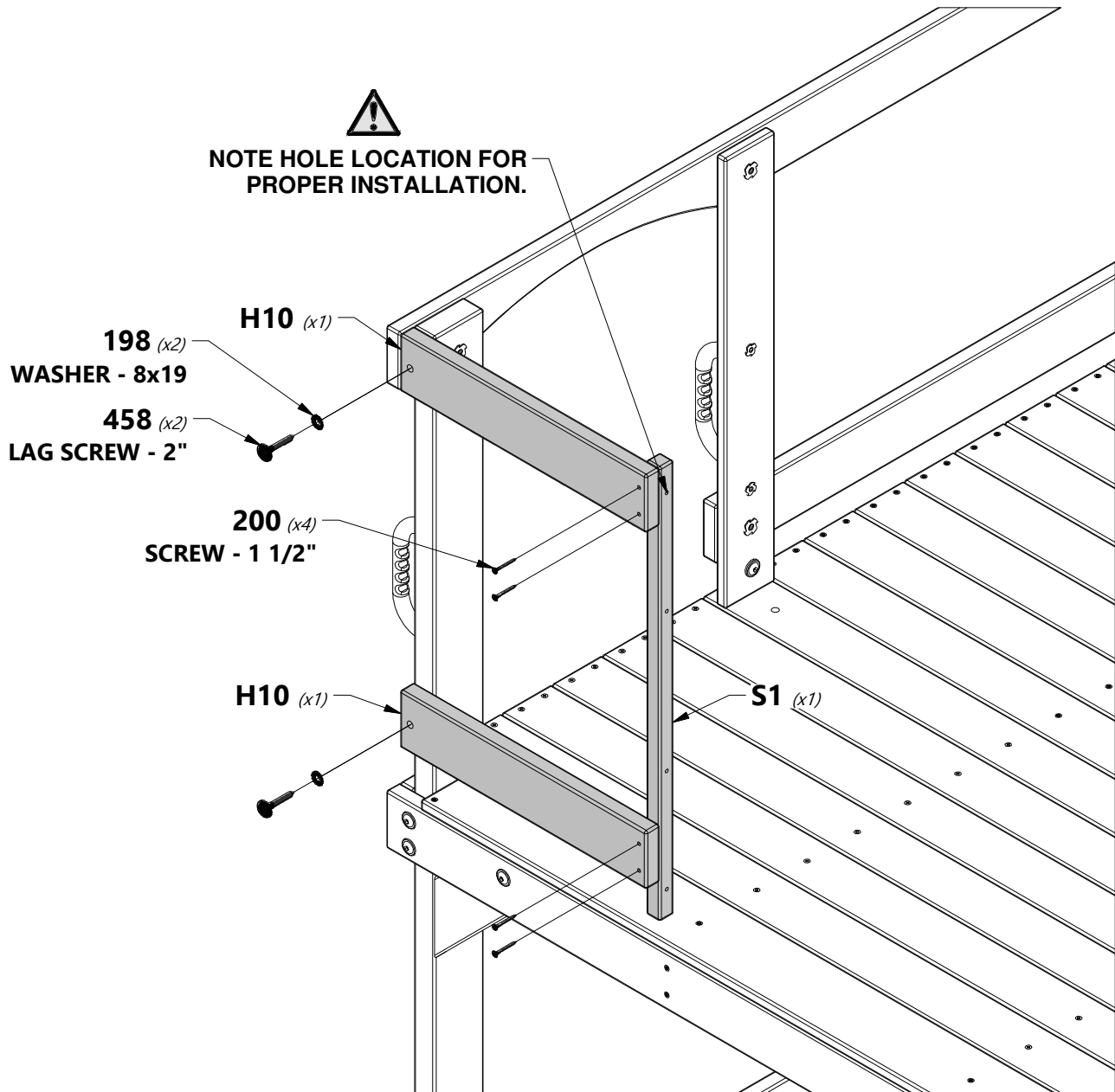

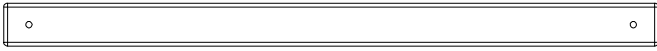
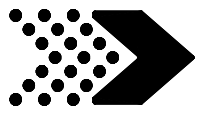

O1 | PICKET - W4L14918
(x3) | 5/8"x1 3/8"x20 1/2" (16x34x520)



H100380 | SCREW PFH BLK
(x6) | 8x1 1/8

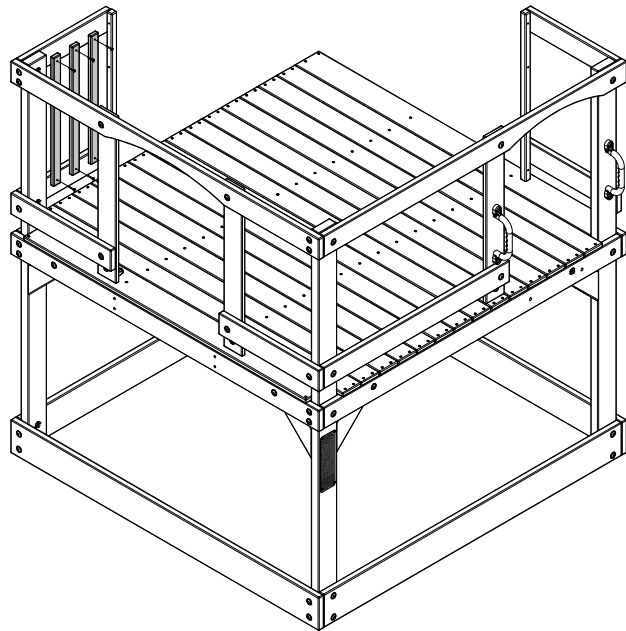
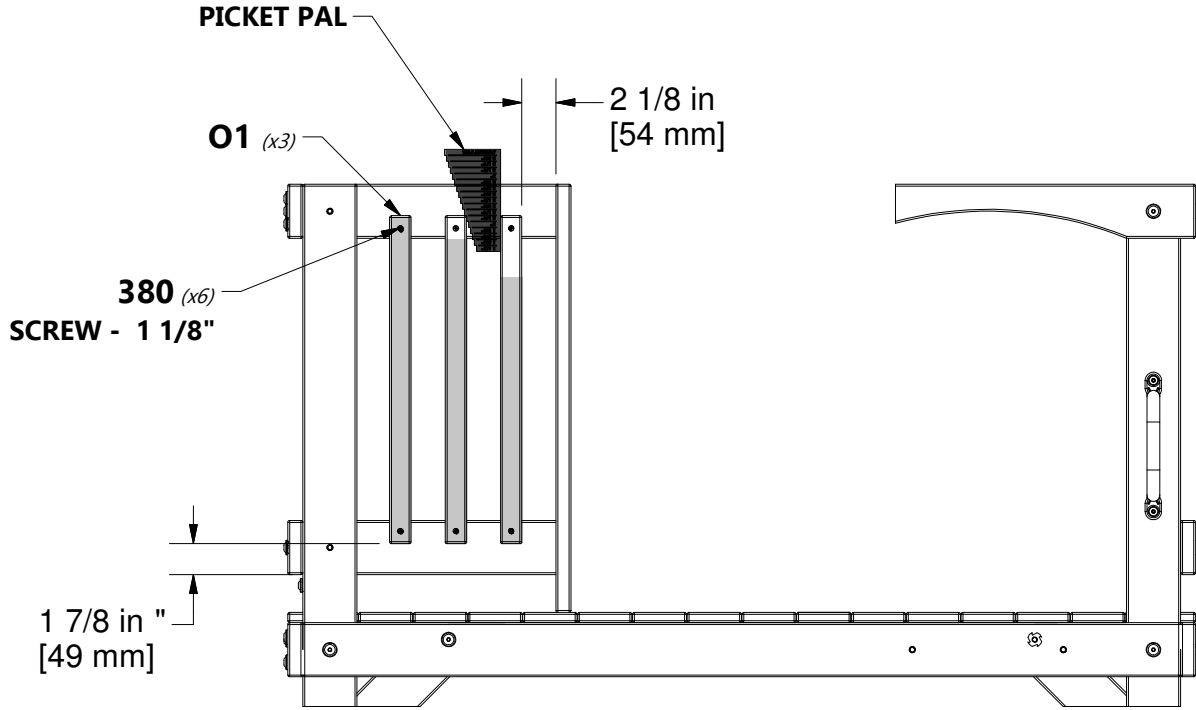

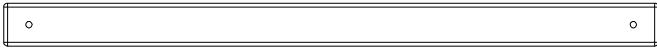
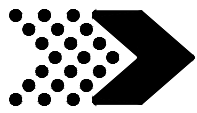

O1 | PICKET - W4L14918
(x6) | 5/8"x1 3/8"x20 1/2" (16x34x520)



H100380 | SCREW PFH BLK
(x12) | 8x1 1/8"

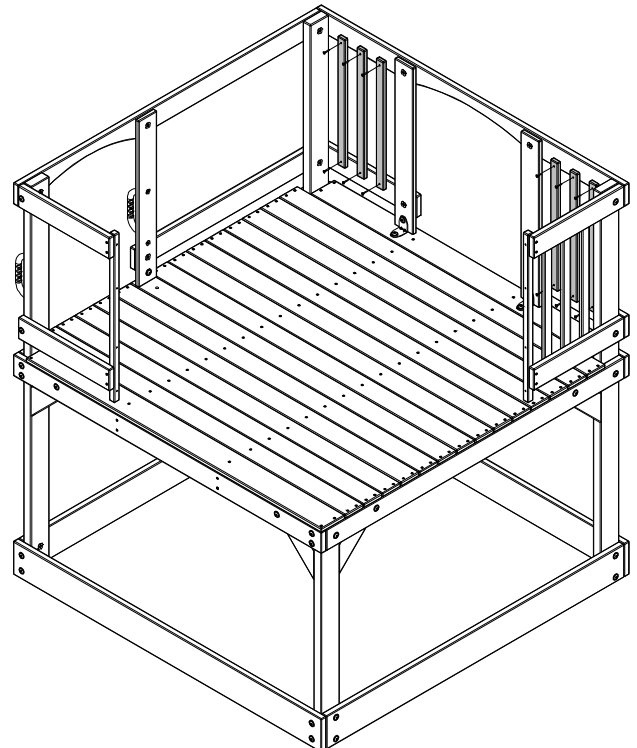
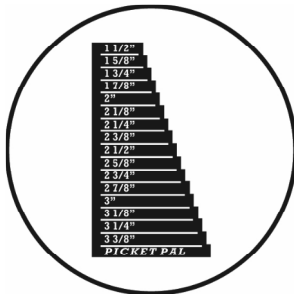
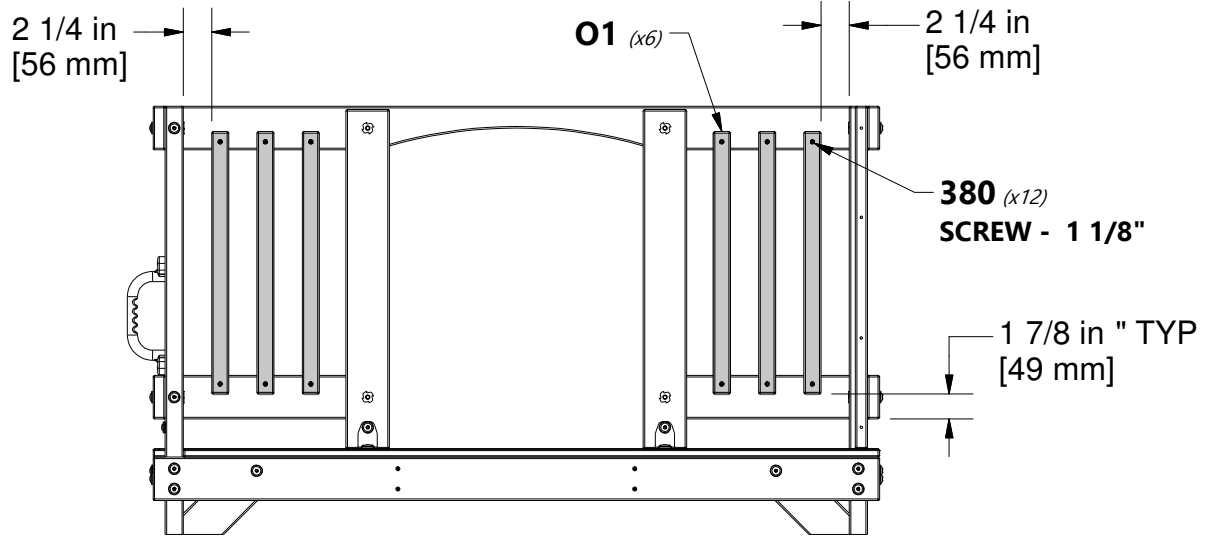

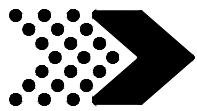

O1 | PICKET - W4L14918
(x7) | 5/8"x1 3/8"x20 1/2" (16x34x520)



H100380 | SCREW PFH BLK
(x14) | 8x1 1/8

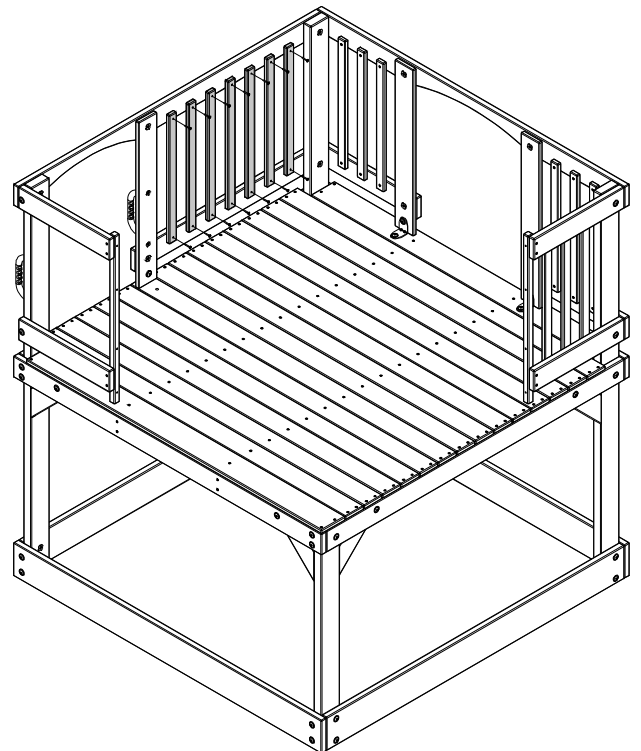
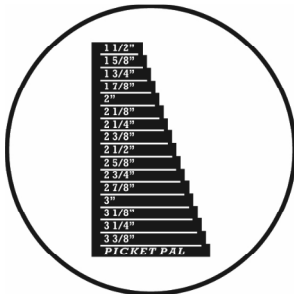
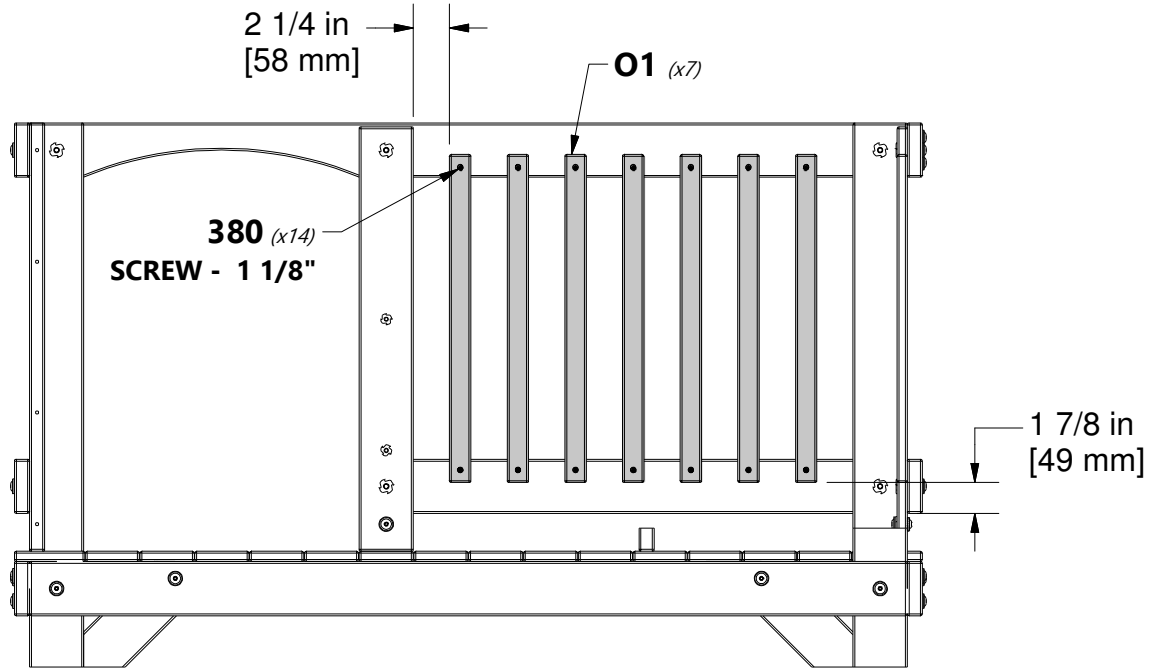

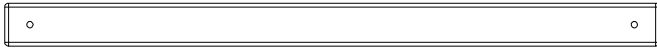
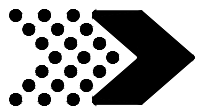

O1 | PICKET - W4L14918
(x3) | 5/8"x1 3/8"x20 1/2" (16x34x520)



H100380 | SCREW PFH BLK
(x6) | 8x1 1/8"

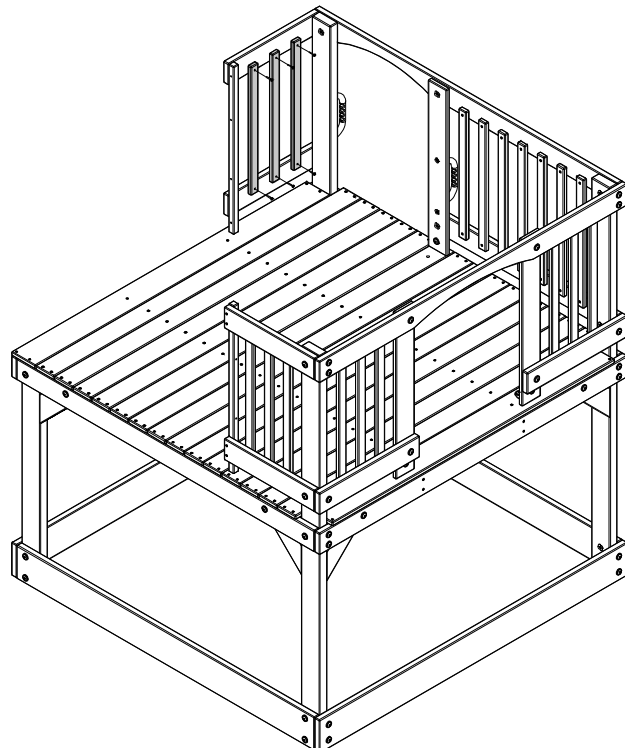
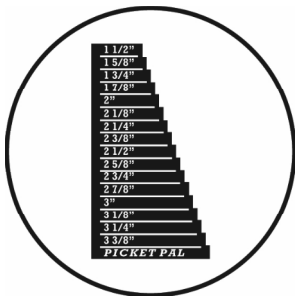
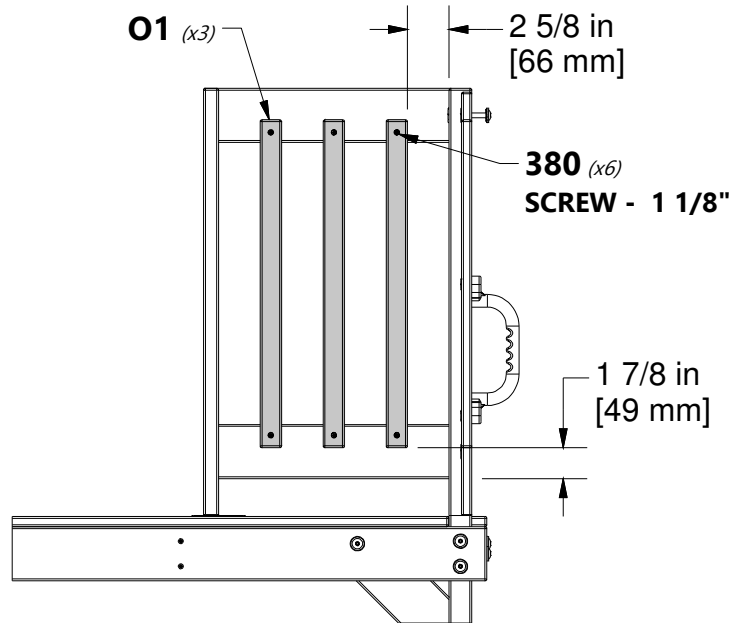

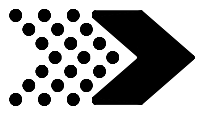

PLAYHOUSE ASSEMBLY

STEP 1

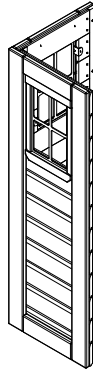

WP1 | FRONT RIGHT CORNER PANEL - W2A03151
(x1)

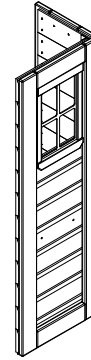

WP2 | REAR RIGHT CORNER PANEL - W2A03154
(x1)

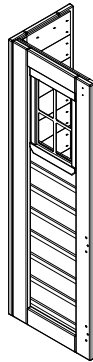

WP3 | FRONT LEFT CORNER PANEL - W2A03157
(x1)

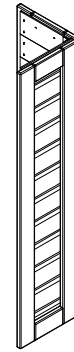

WP4 | REAR LEFT CORNER PANEL - W2A03160
(x1)



NOTE:
STAND THE (4) CORNER WALL ASSEMBLIES AS SHOWN BELOW.

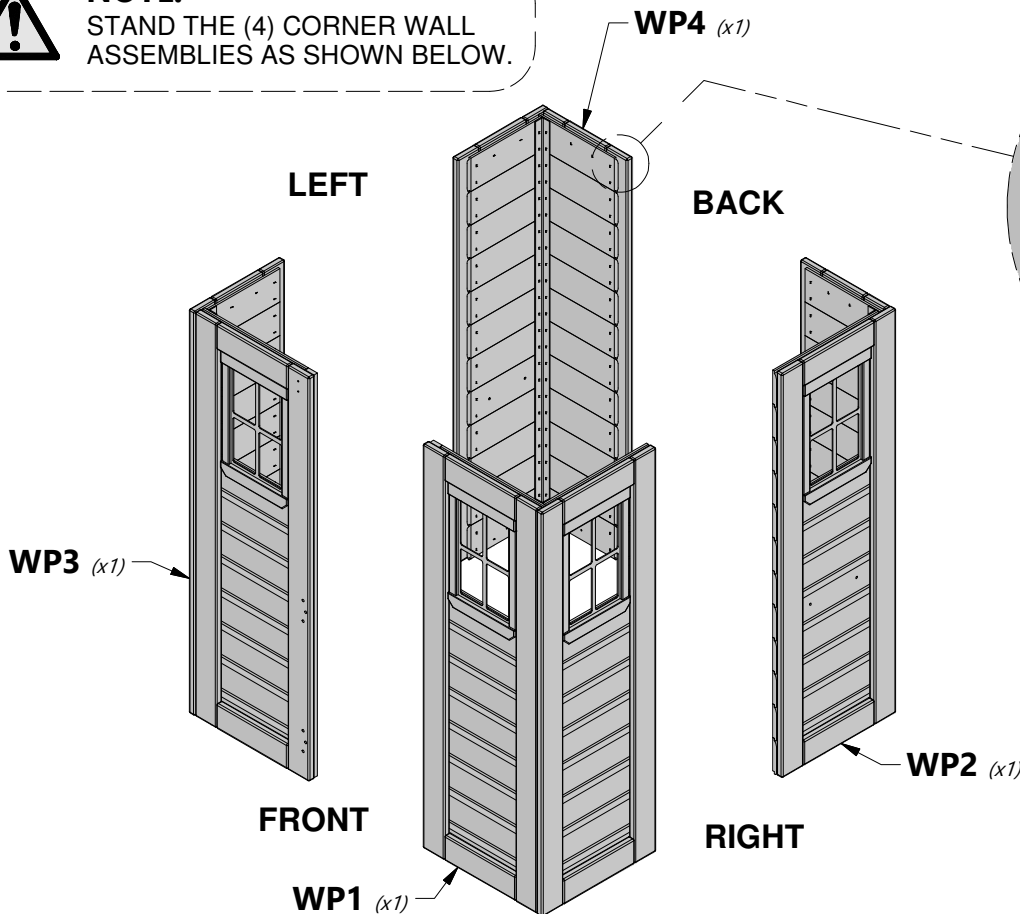

NOTE THE PROFILE OF THE WALL BOARDS. THE TONGUE FACES TOWARD THE TOP OF THE PANELS.

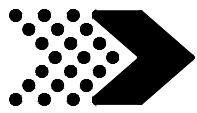

PLAYHOUSE ASSEMBLY

STEP 2

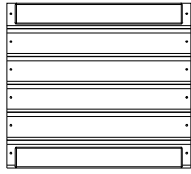

WP6 | LEFT CENTER PANEL - W2A03164
(x1) | 1 1/4"x18 7/8"x20 7/8" (32x478x536)



H100385 | SCREW PFH BLK
(x12) | 8x1

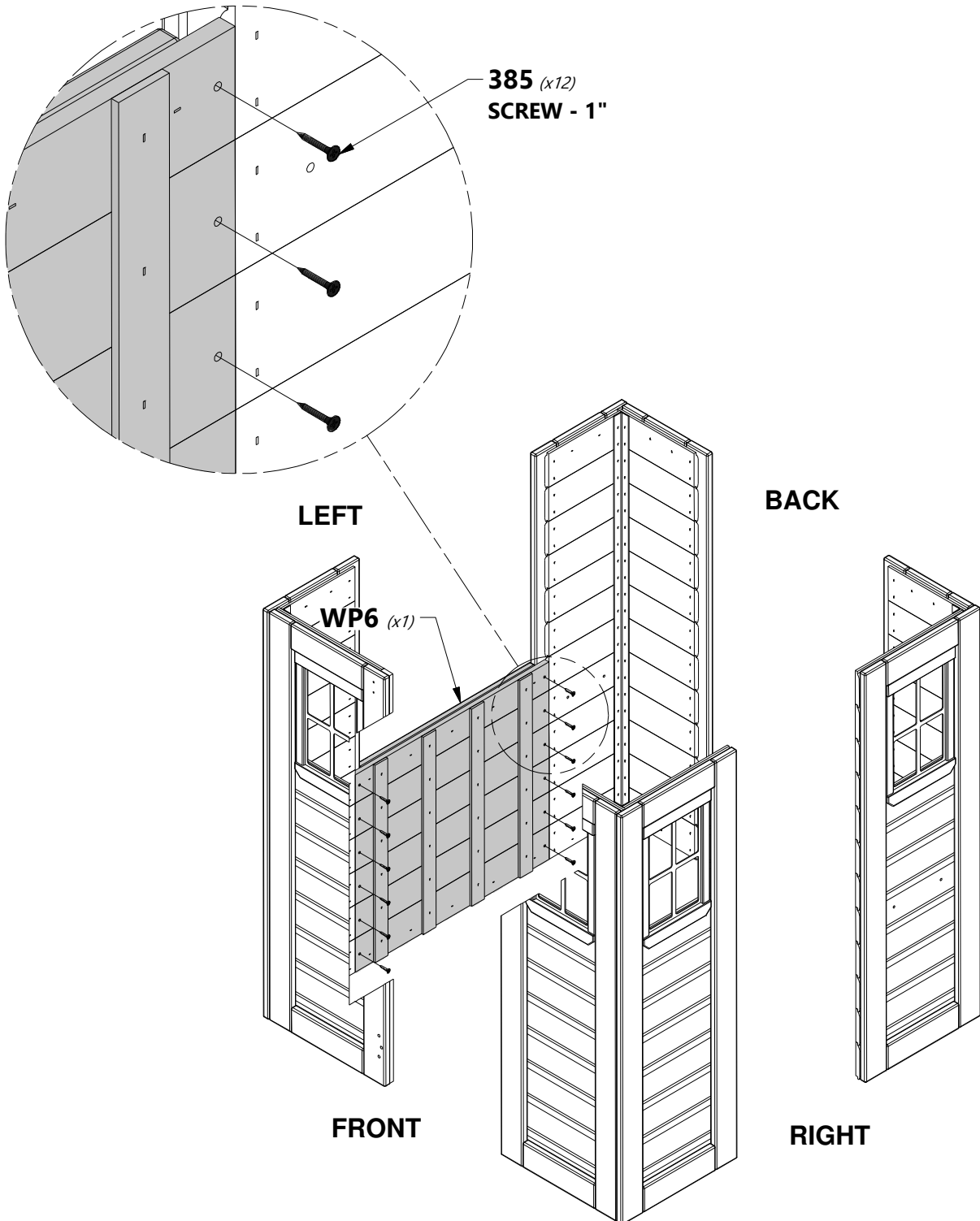

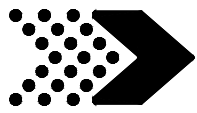

PLAYHOUSE ASSEMBLY

STEP 3

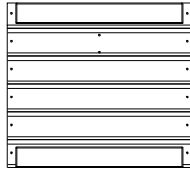

WP5 | REAR CENTER PANEL - W2A03163
(x1) | 1 1/4"x18 7/8"x20 7/8" (32x478x536)



H100385 | SCREW PFH BLK
(x12) | 8x1

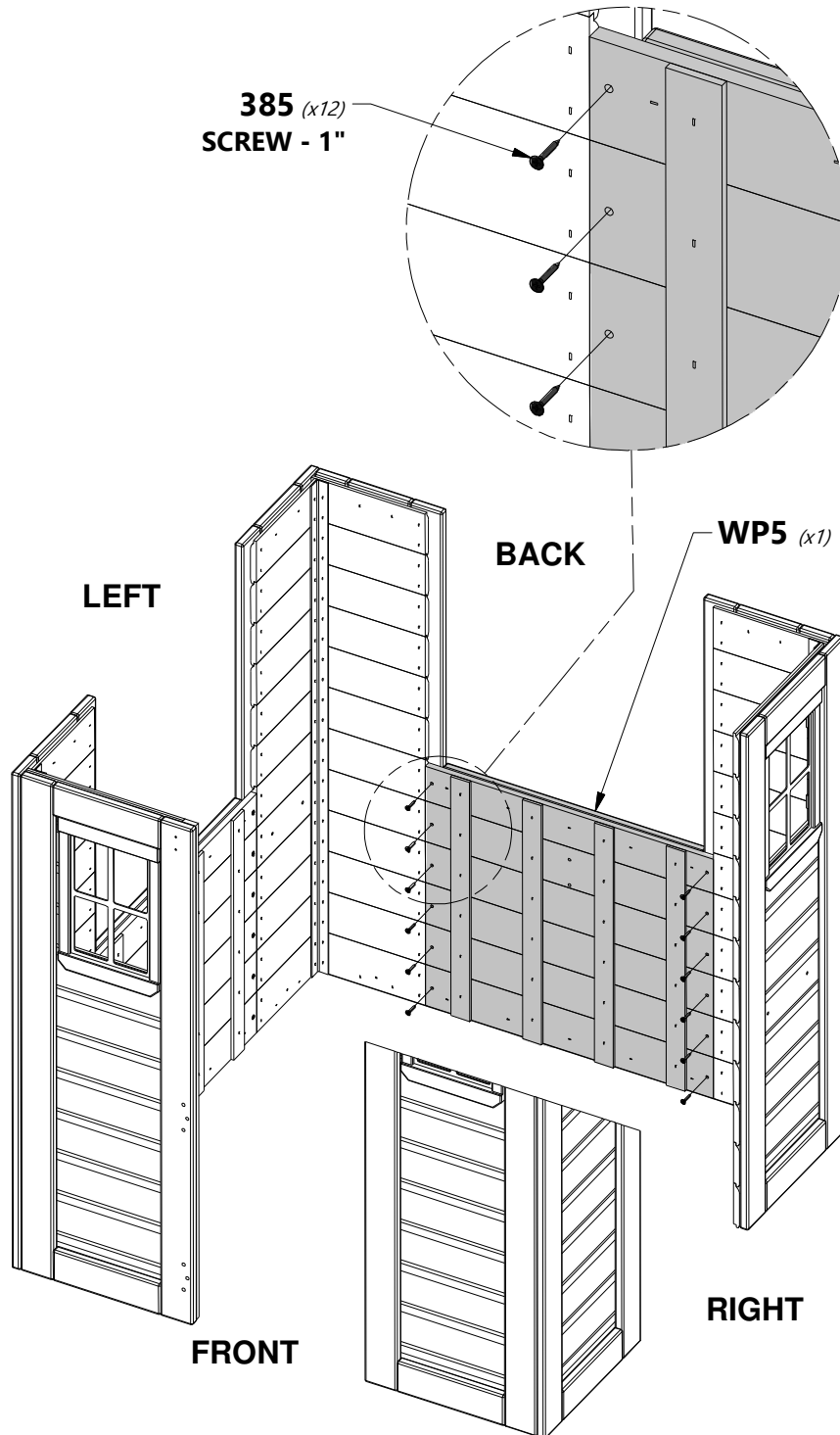

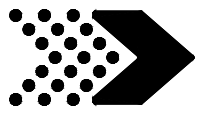

PLAYHOUSE ASSEMBLY

STEP 4

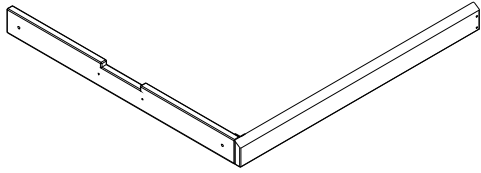

WP8 | HEADER ASSEMBLY - W2A03165
(x2)



H100201 | SCREW PFH BLK
(x4) | 8x2-1/2



ALL INTERIOR
SURFACES
ARE FLUSH.

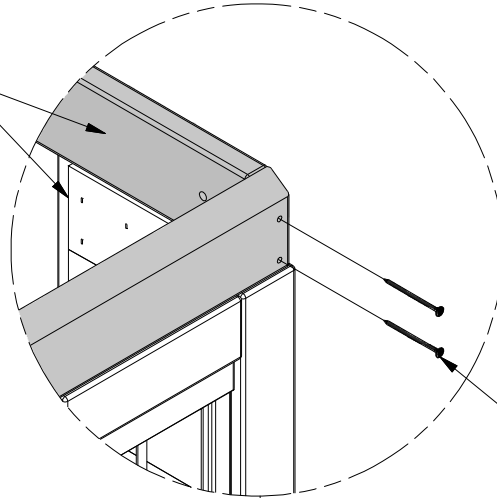

201 (x4)
SCREW - 2 1/2"

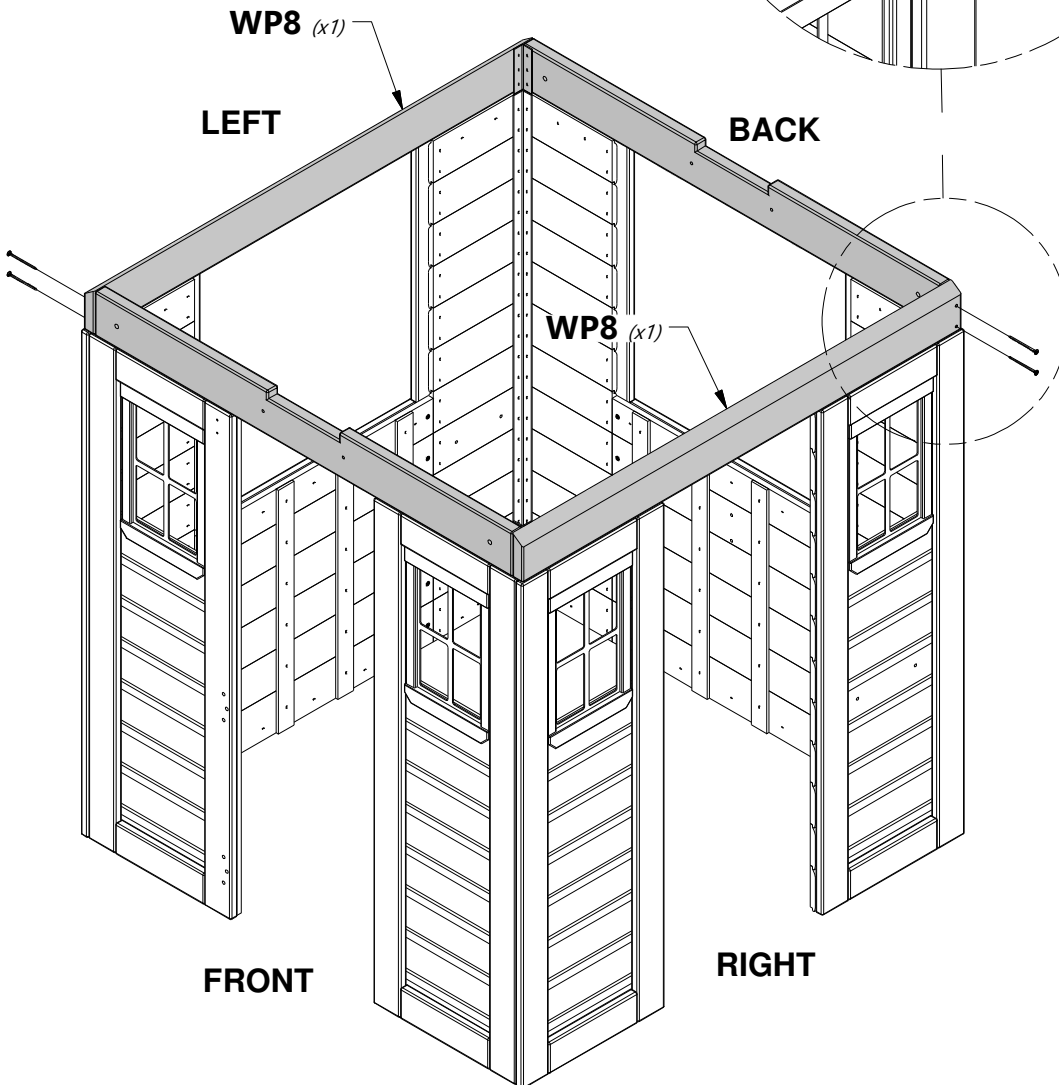

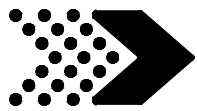

PLAYHOUSE ASSEMBLY

STEP 5

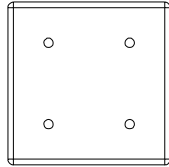

N1 | TIE STRAP - W4L14915
(x8) | 5/8"x3 3/8"x3 3/8" (16x86x86)



H100387 | SCREW PFH BLK
(x32) | 8x1-1/4



INSTALL WITH THE EDGE SURFACE OF 'N1' FLUSH WITH THE END OF WALL BOARD, AS SHOWN.

N1 (x8)

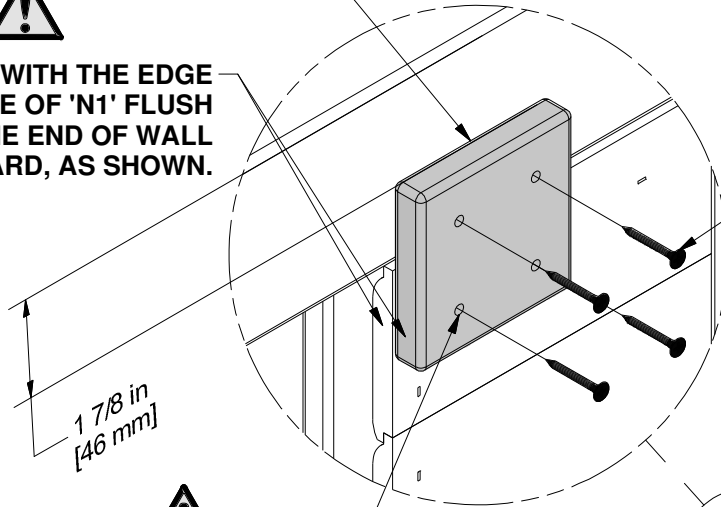

387 (x32)
SCREW - 1 1/4"



DRILL 1/8" - 3mm PILOT HOLE, THIS HOLE ONLY. THRU SIDING ONLY.

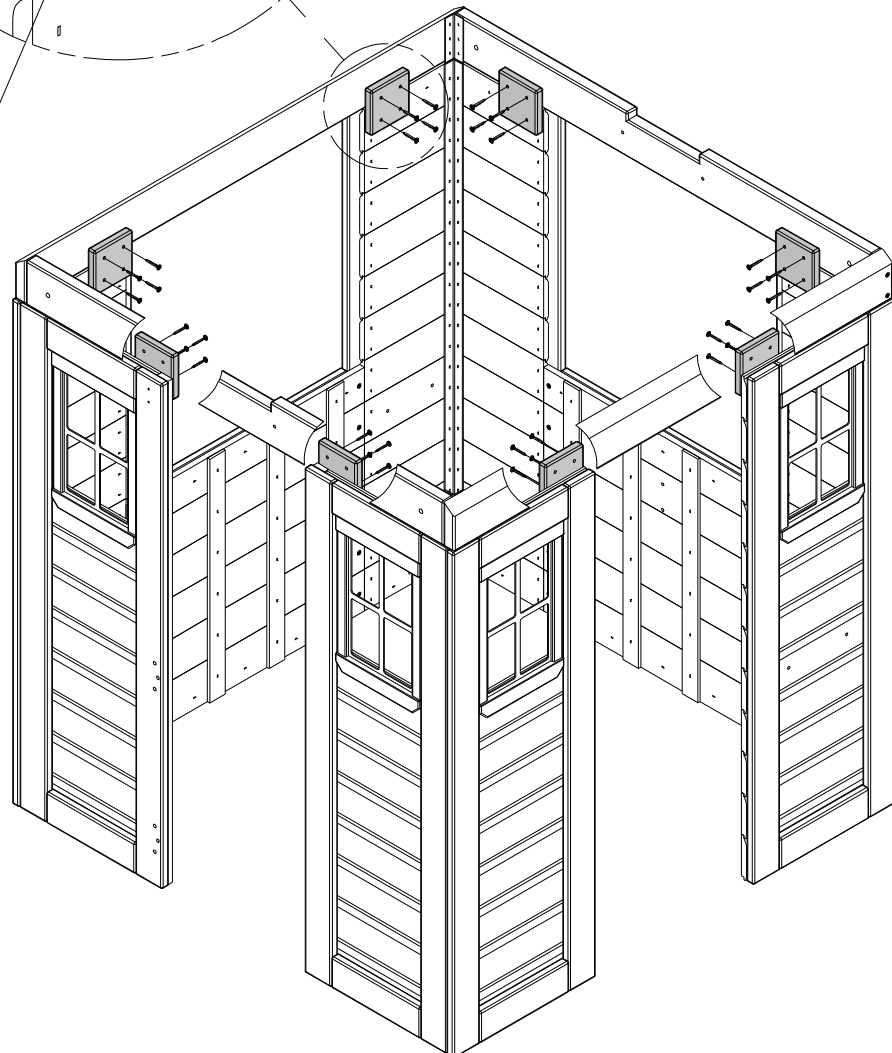

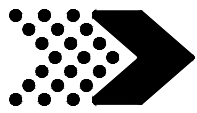

PLAYHOUSE ASSEMBLY

STEP 6

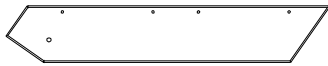

L3 | GABLE BOARD - W4L14906
(x4) | 5/8"x4 3/8"x25 3/8" (16x112x644)



H100171 | BOLT WH BLK
(x4) | 1/4x1



H100405 | WASHER LOCK EXT BLK
(x4) | 6x15



H100399 | NUT BARREL WH BLK
(x4) | 1/4x7/8



H100400 | WASHER LOCK EXT BLK
(x4) | 8x15

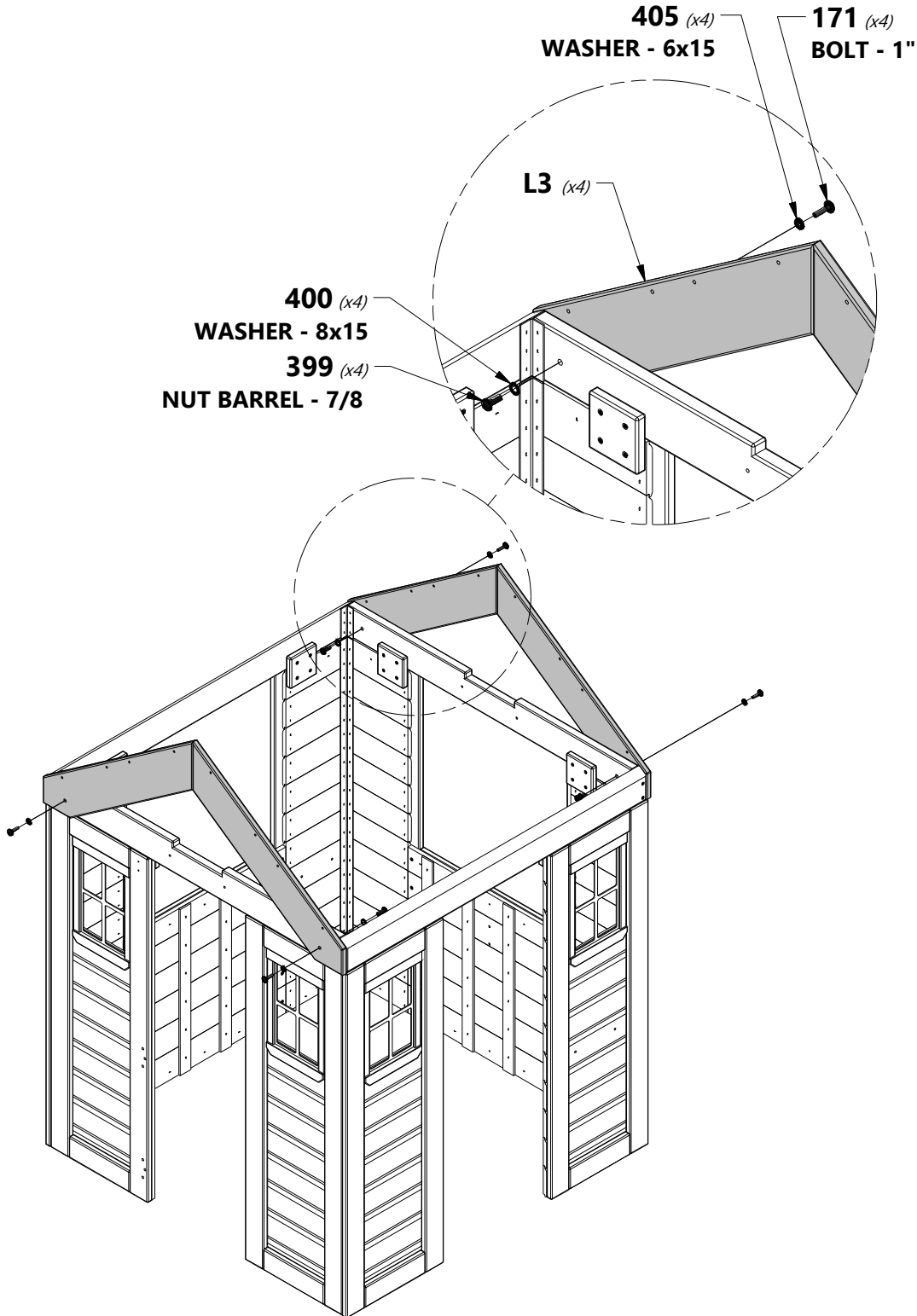

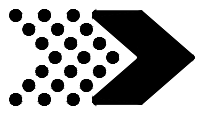

PLAYHOUSE ASSEMBLY

STEP 7

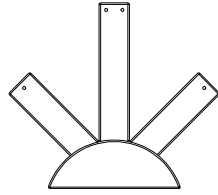

A100361 | **PLASTIC SUNBURST**
(x2)



H100387 | **SCREW PFH BLK**
(x4) | 8x1-1/4



H100392 | **SCREW PWH BLK**
(x8) | 8x3/4

361 (x2)
PLASTIC SUNBURST

392 (x8)
SCREW - 3/4"

387 (x4)
SCREW - 1 1/4"

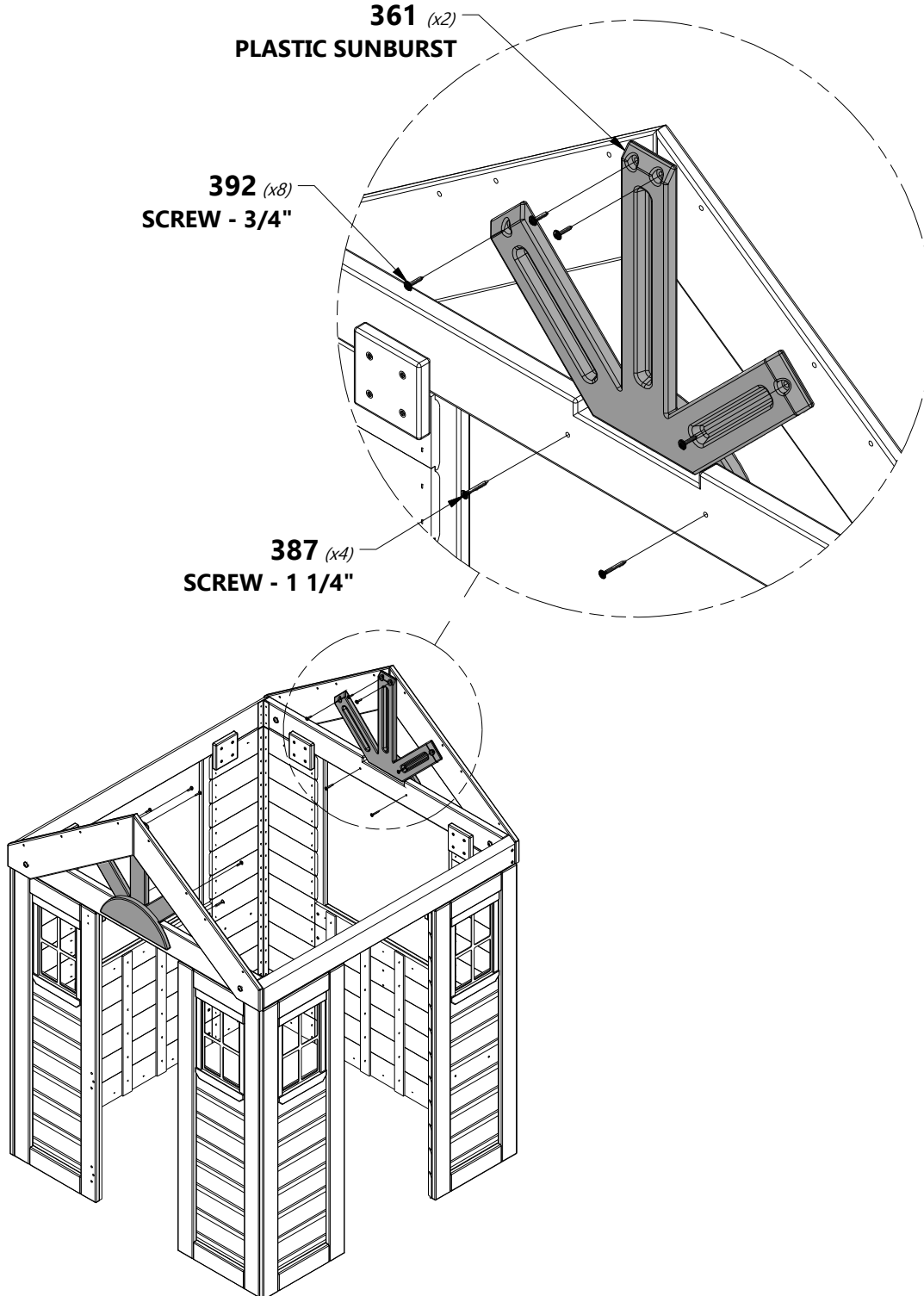

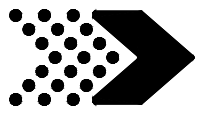

PLAYHOUSE ASSEMBLY

STEP 8



RP2 | UPPER ROOF PANEL - W2A03167
(x2) | 1 3/8"x12 3/4"x44 7/8" (35x324x1140)



H100200 | SCREW PFH BLK
(x8) | 8x1 1/2

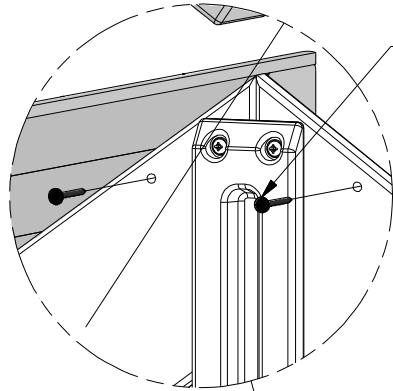

200 (x8)
SCREW - 1 1/2"

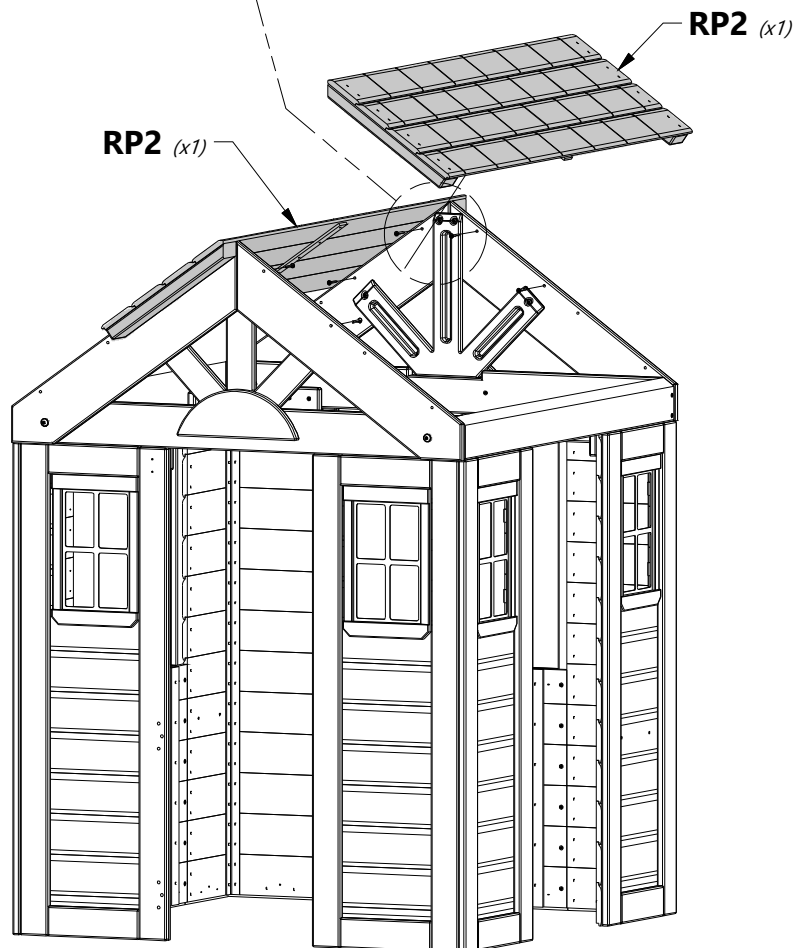

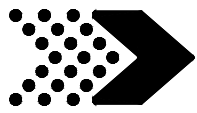

PLAYHOUSE ASSEMBLY

STEP 9



RP1 | LOWER ROOF PANEL - W2A03166
(x2) | 1 3/8"x13"x44 7/8" (35x329x1140)



H100200 | SCREW PFH BLK
(x8) | 8x1 1/2

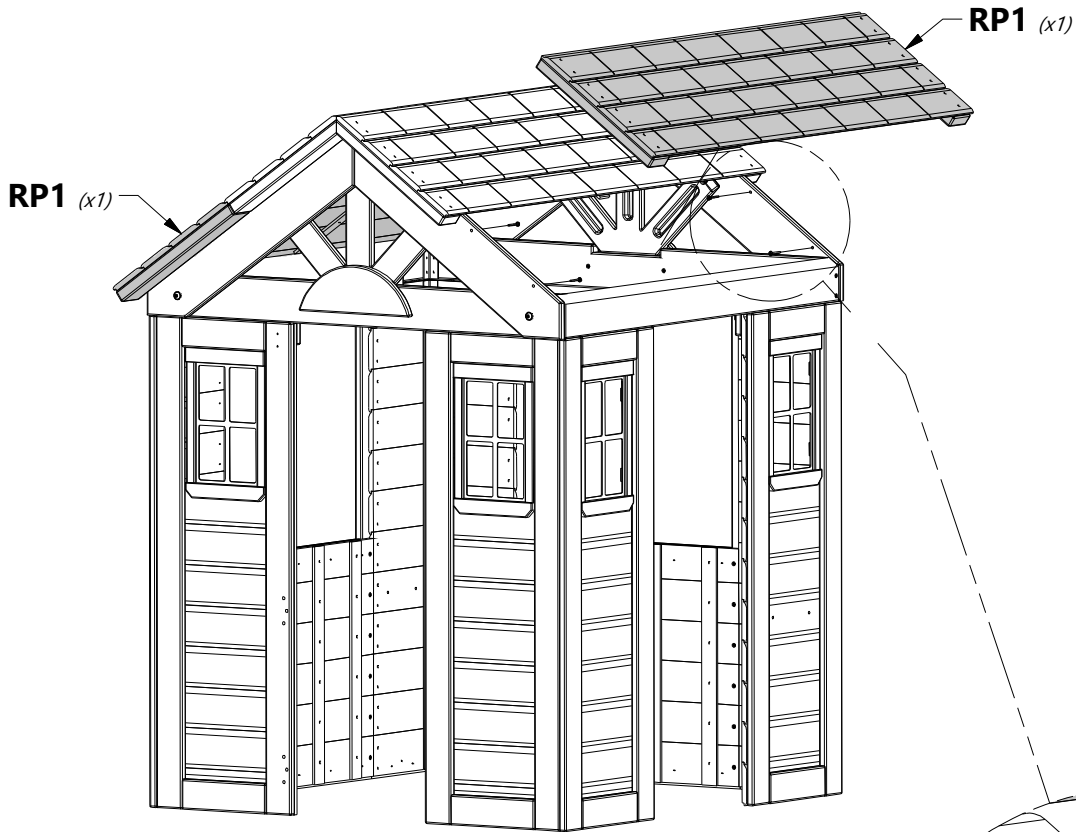

200 (x8)
SCREW - 1 1/2"

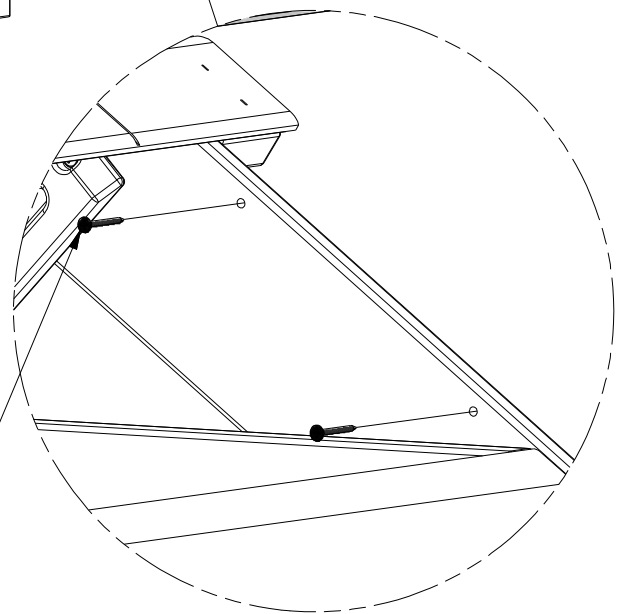

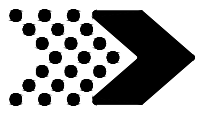

PLAYHOUSE ASSEMBLY

STEP 10



N2 | WINDOW SHELF - W4L14917
(x1) | 5/8"x2 3/8"x19 1/8" (16x60x485)



H100387 | SCREW PFH BLK
(x2) | 8x1-1/4

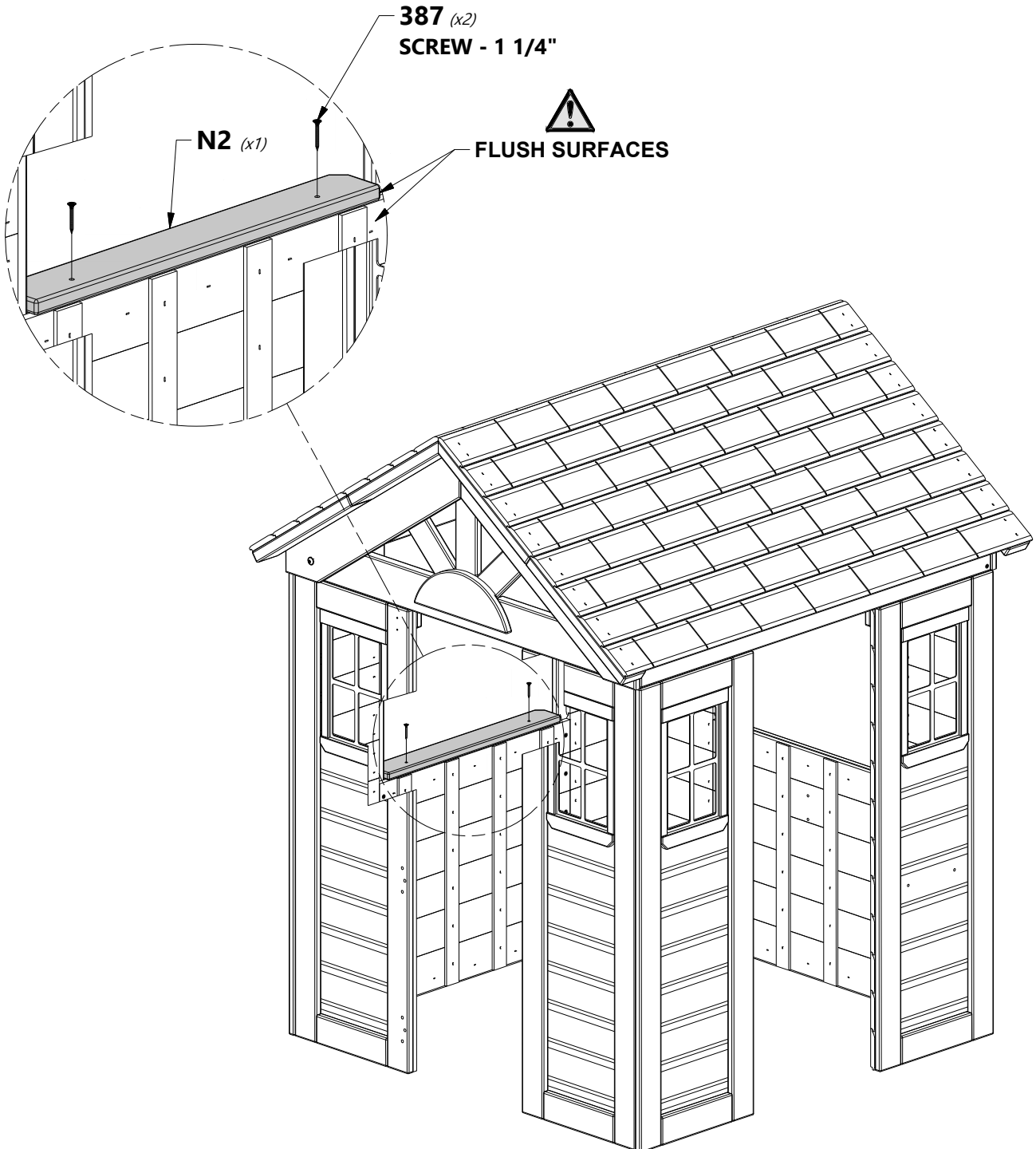

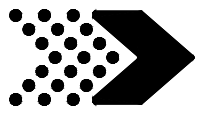

PLAYHOUSE ASSEMBLY

STEP 11



N2 | WINDOW SHELF - W4L14917
(x1) | 5/8"x2 3/8"x19 1/8" (16x60x485)



H100387 | SCREW PFH BLK
(x2) | 8x1-1/4

387 (x2)
SCREW - 1 1/4"



FLUSH SURFACES

N2 (x1)

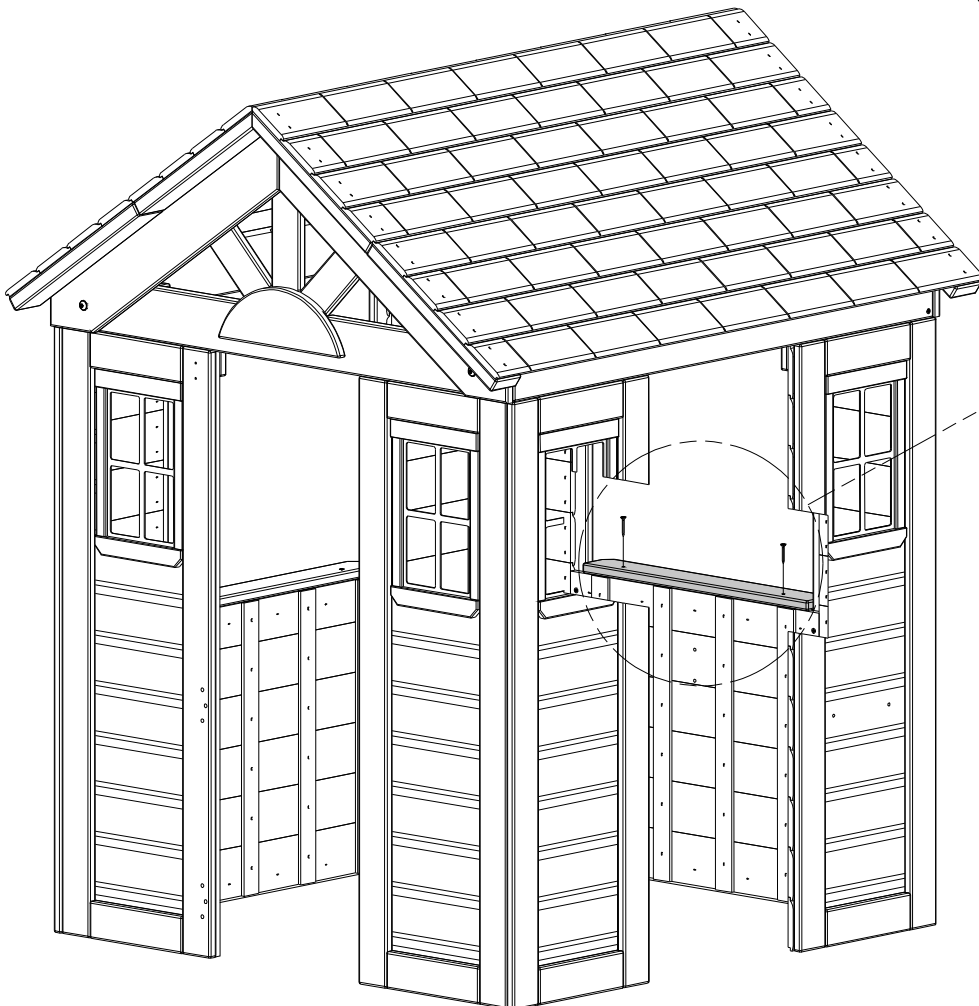
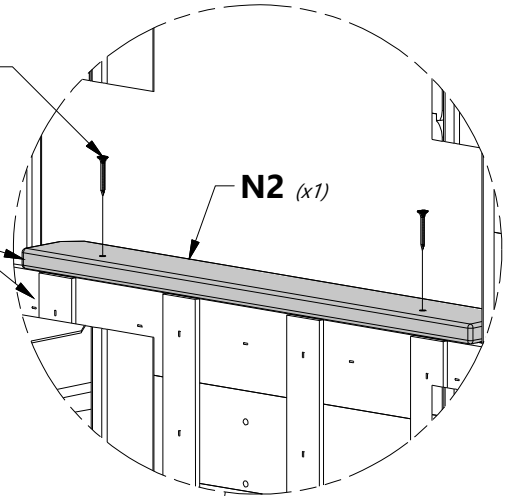

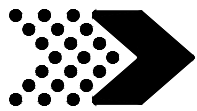

PLAYHOUSE ASSEMBLY

STEP 12



A4M00555 | 90° L-BRACKET - BLK
(x8)



H100202 | SCREW PWH BLK
(x8) | 8x5/8



**ALIGN BRACKETS WITH
PILOT HOLES.**

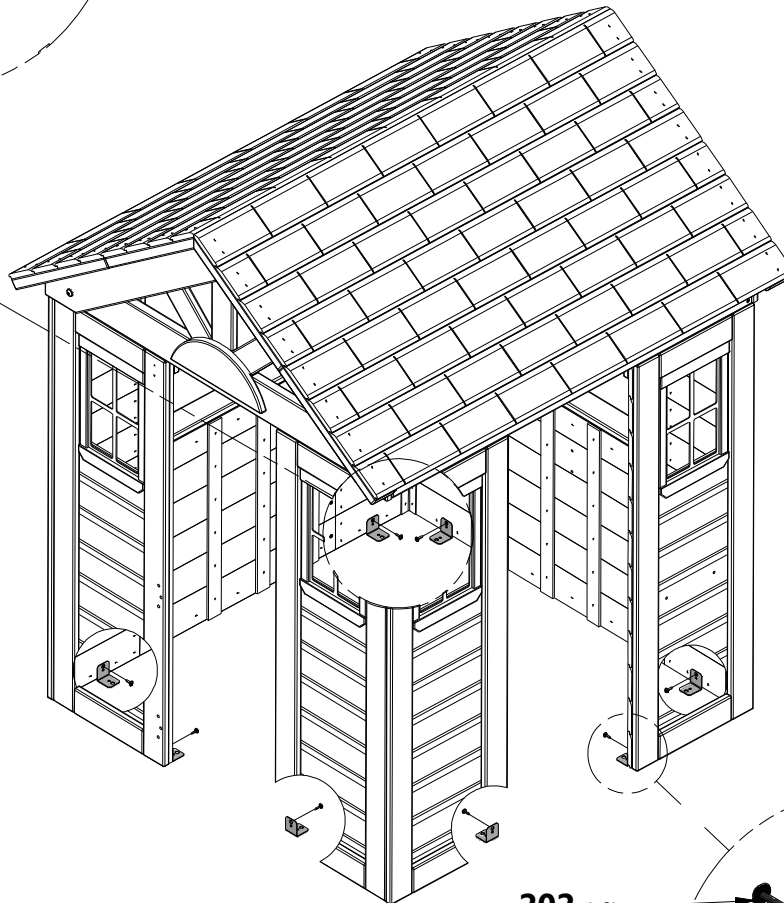
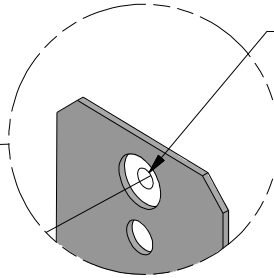
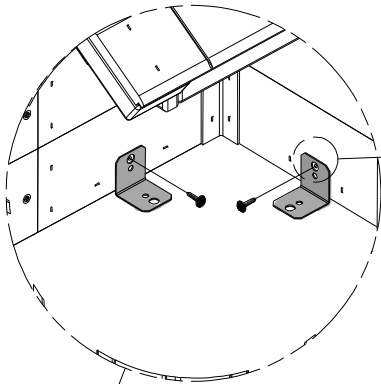

202 (x8)
SCREW - 5/8"

555 (x8)
90° L-BRACKET - BLK



**EDGES FLUSH IN
DOOR OPENINGS.**

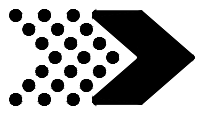

PLAYHOUSE ASSEMBLY

STEP 13



H3 | COUNTER TOP SUPPORT - W4L14919
(x1) | 1"x3 3/8"x8 3/8" (24x86x214)



H100200 | SCREW PFH BLK
(x2) | 8x1 1/2

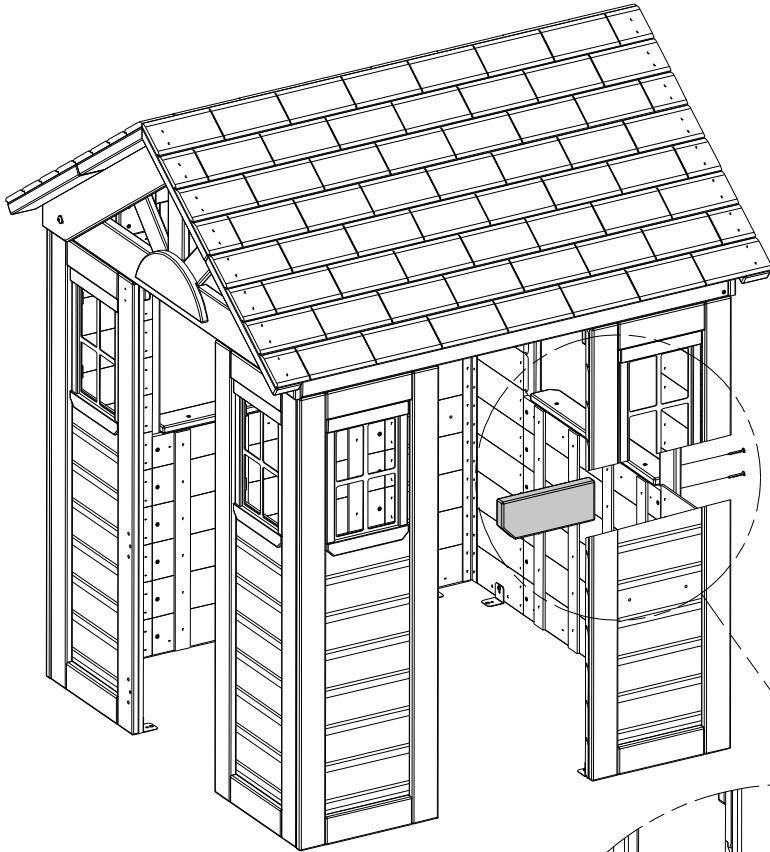

H3 (x1)

200 (x2)
SCREW - 1 1/2"

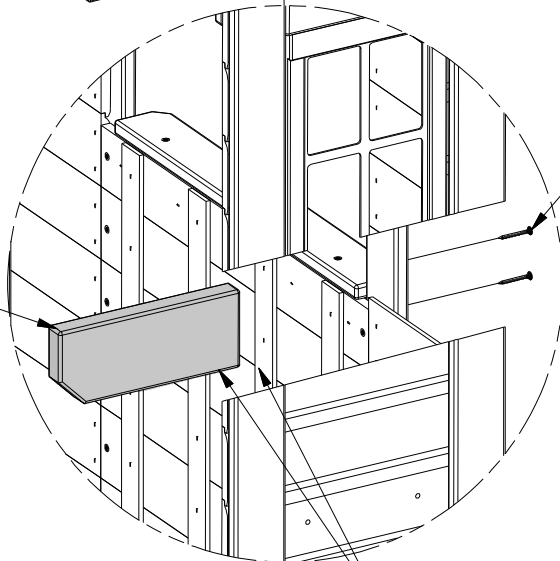

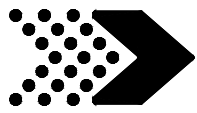

**ALIGN PILOT HOLES IN H3
WITH HOLES IN WALL PANEL.**

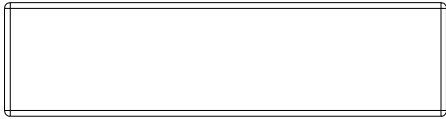

PLAYHOUSE ASSEMBLY

STEP 14



J3 | COUNTER TOP SUPPORT - W4L14903
(x2) | 1"x2 3/8"x9 1/4" (24x60x234)



H100387 | SCREW PFH BLK
(x4) | 8x1-1/4

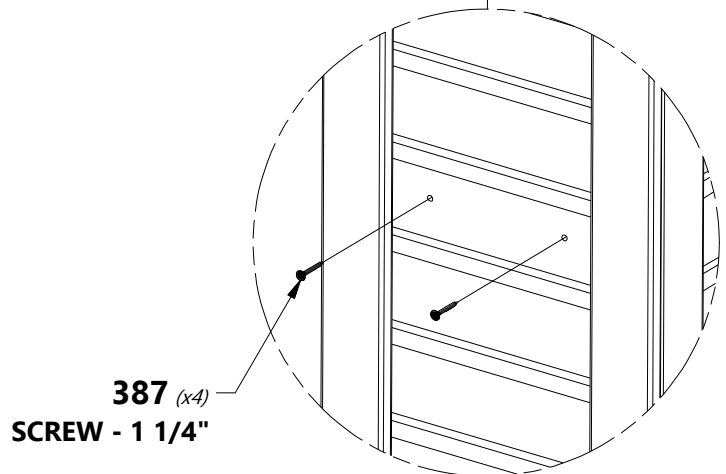
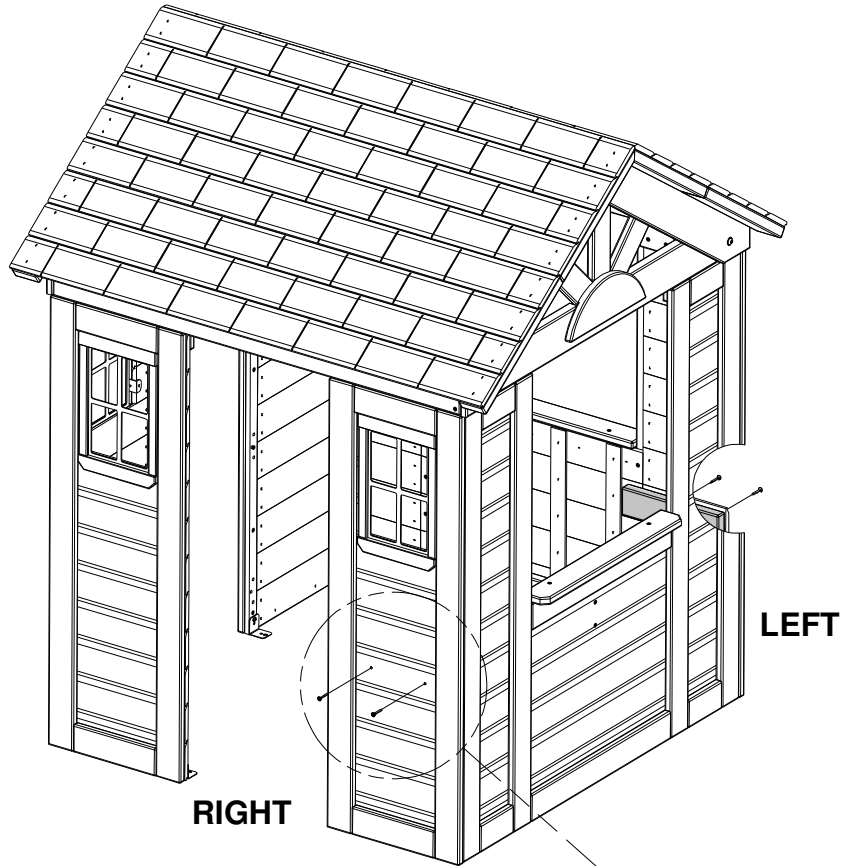
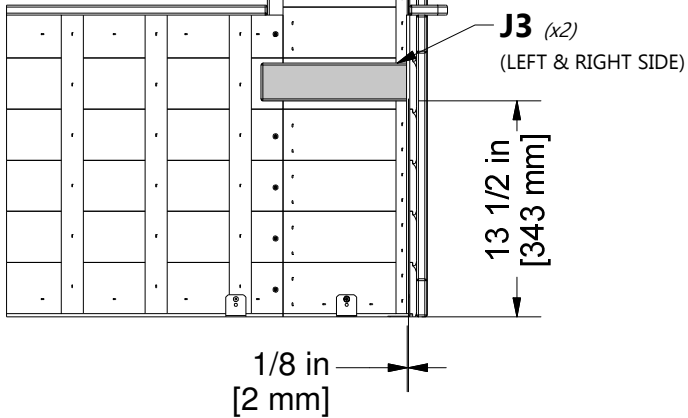
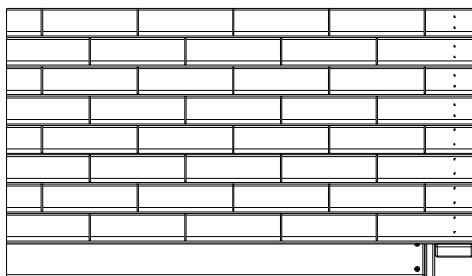
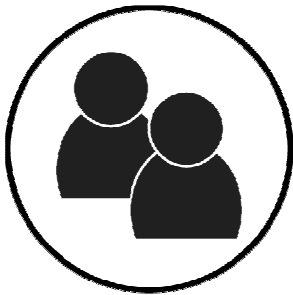

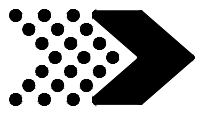

PLAYHOUSE ASSEMBLY

STEP 15



Q1 | COUNTER TOP - W4L14907
(x2) | 1"x4 3/8"x36 3/4" (24x112x934)



H100200 | SCREW PFH BLK
(x10) | 8x1 1/2

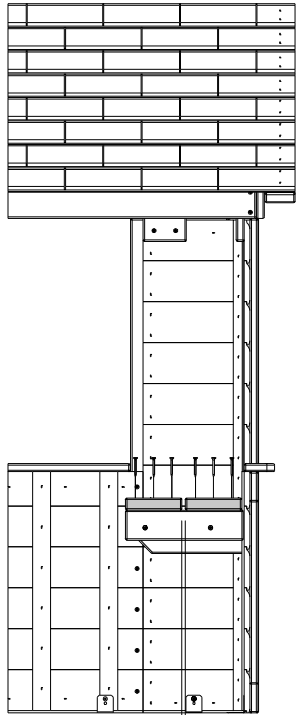

9/32 in
[7 mm]

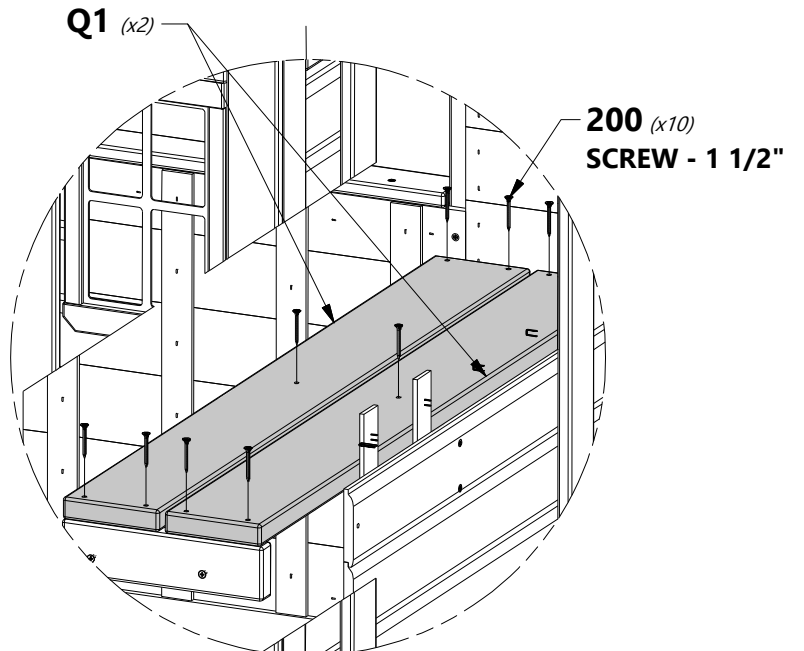
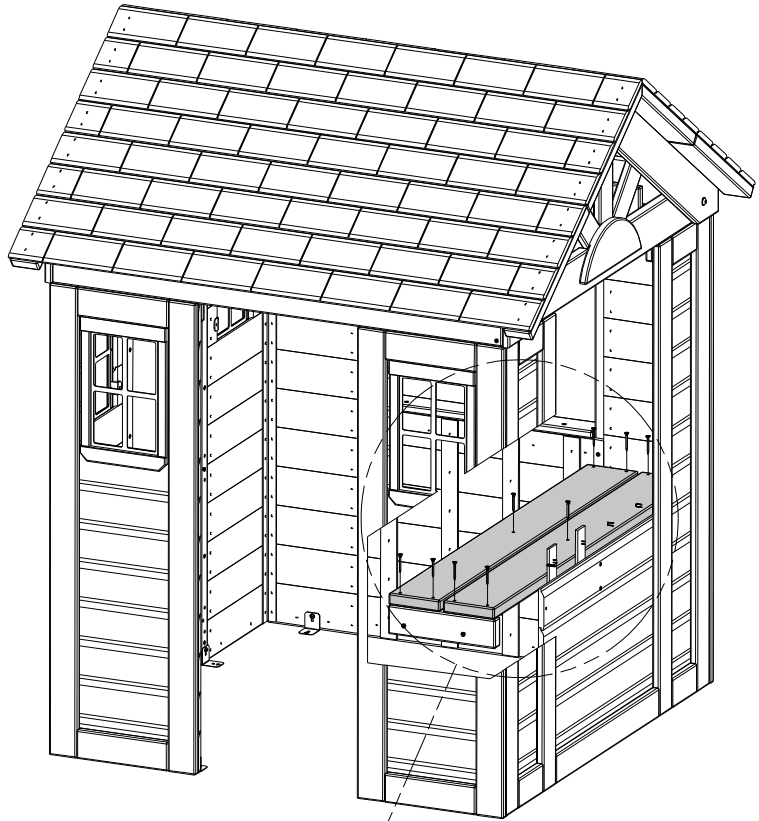

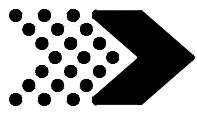

PLAYHOUSE ASSEMBLY

STEP 16

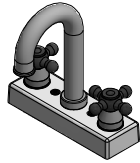

A6P00024 | FAUCET KIT
(x1)



H100200 | SCREW PFH BLK
(x2) | 8x1 1/2

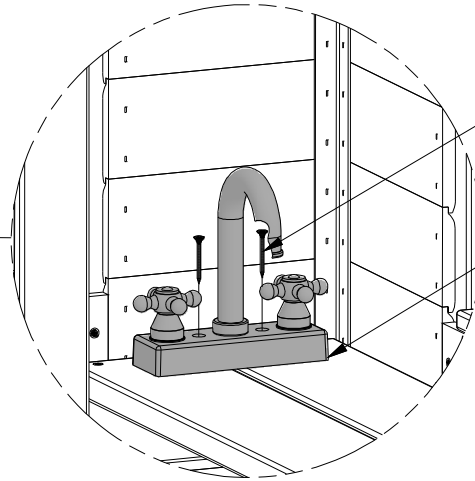
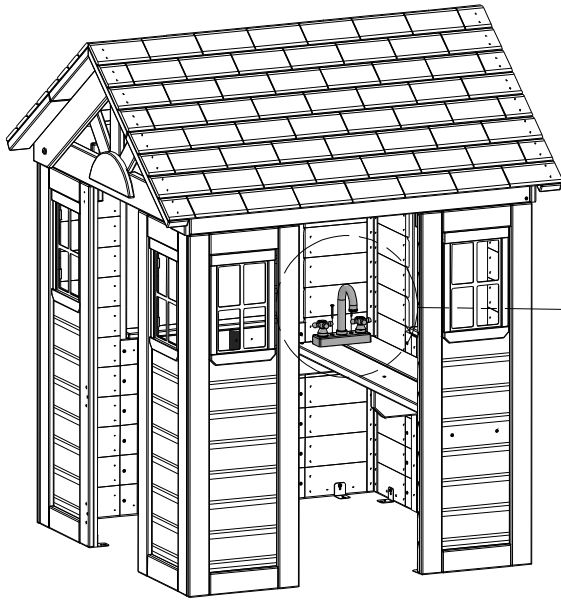

200 (x2)
SCREW - 1 1/2"

024 (x1)
FAUCET KIT

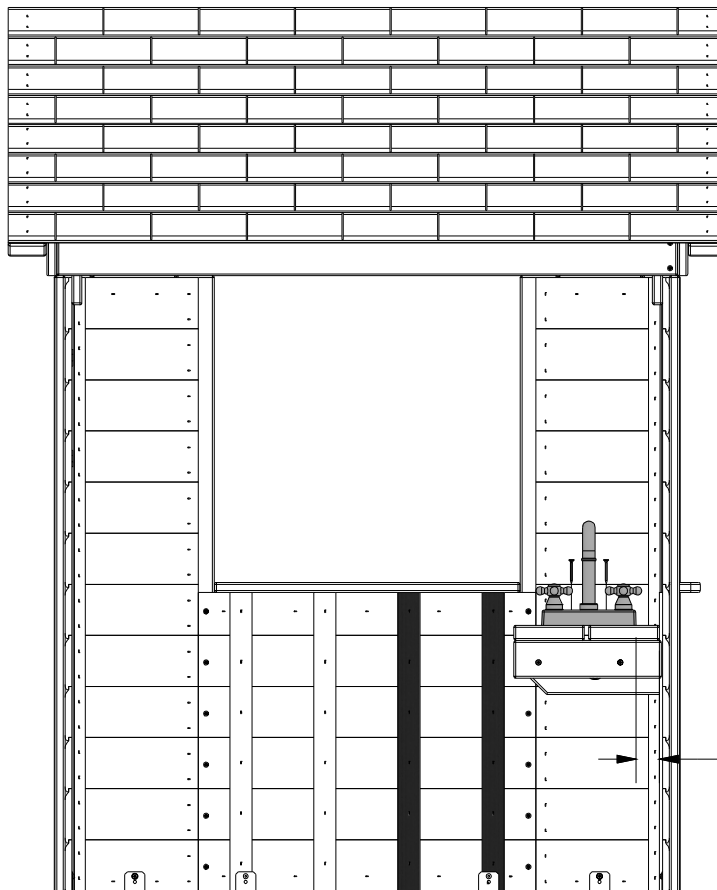

1 1/2 in
[37 mm]
(FAUCET LOCATION)

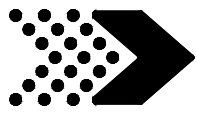

PLAYHOUSE ASSEMBLY

STEP 17

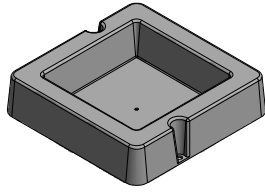

A6P00032 | SURFACE MOUNT BASIN
(x1)



H100202 | SCREW PWH BLK
(x2) | 8x5/8

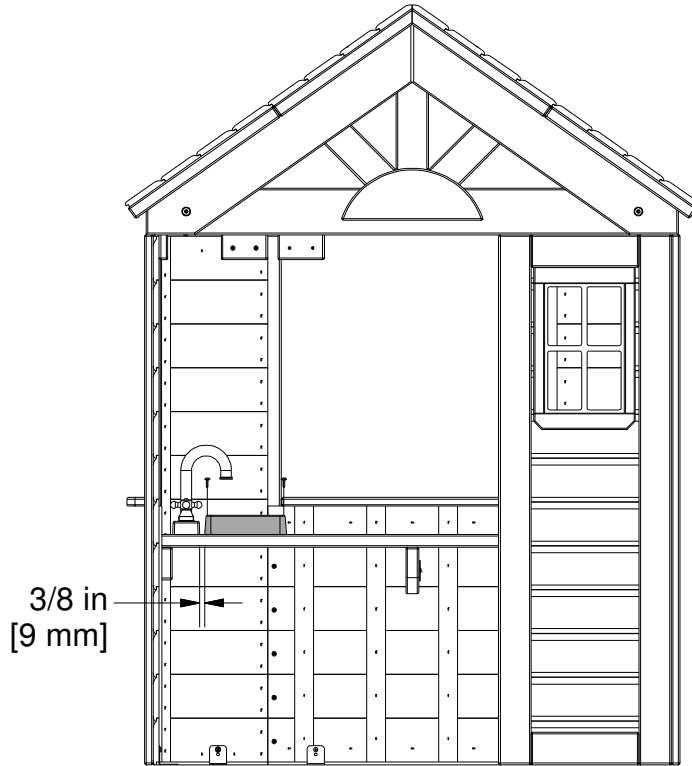

3/8 in
[9 mm]

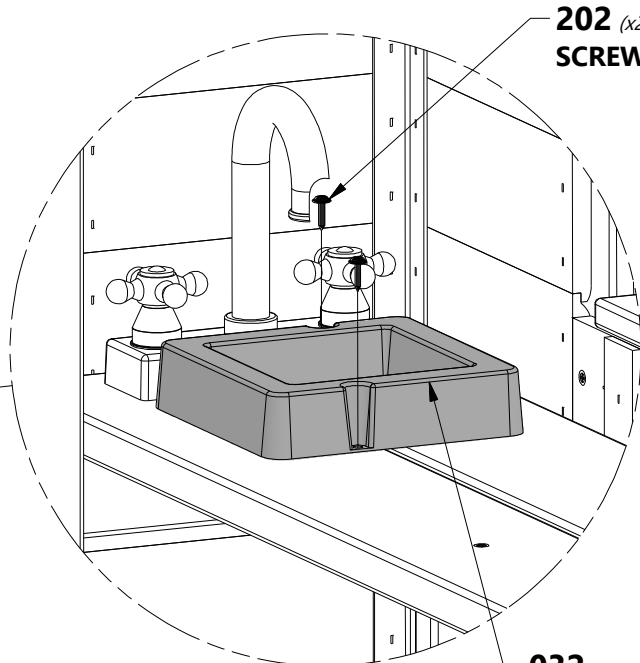
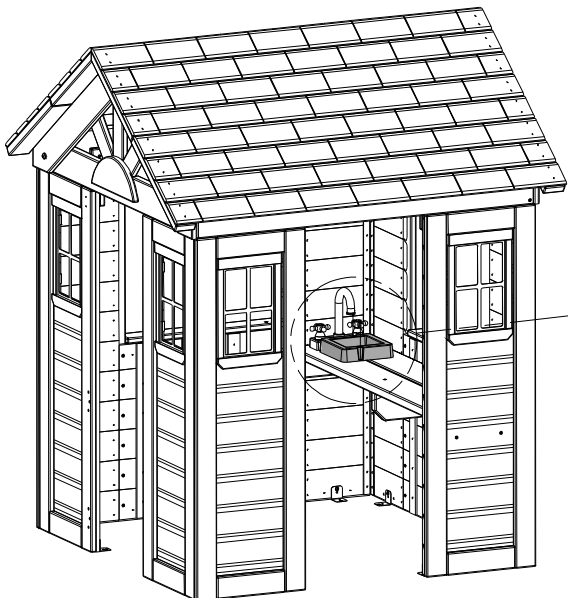

202 (x2)
SCREW - 5/8"

032 (x1)
SURFACE MOUNT BASIN

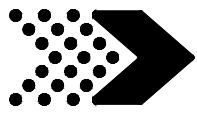

PLAYHOUSE ASSEMBLY

STEP 18

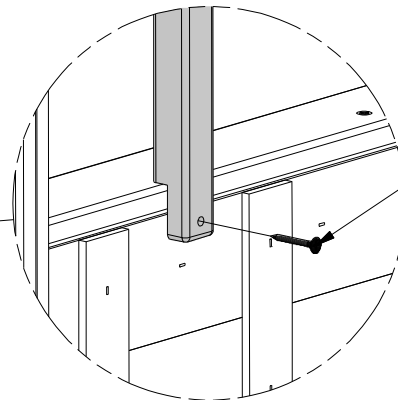
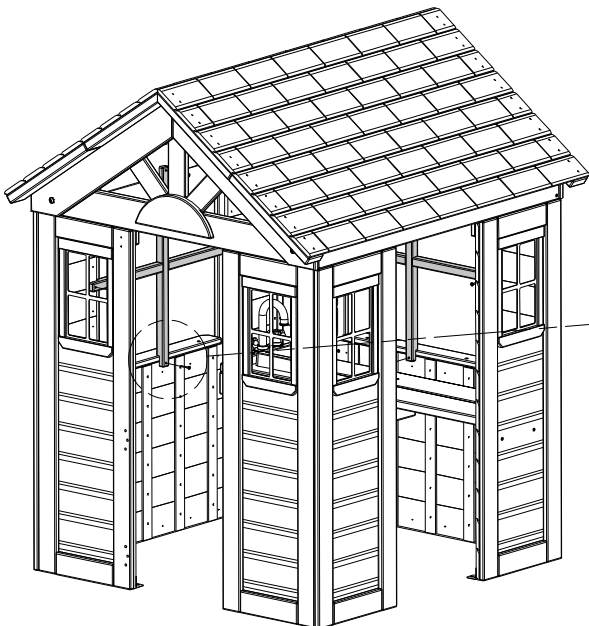
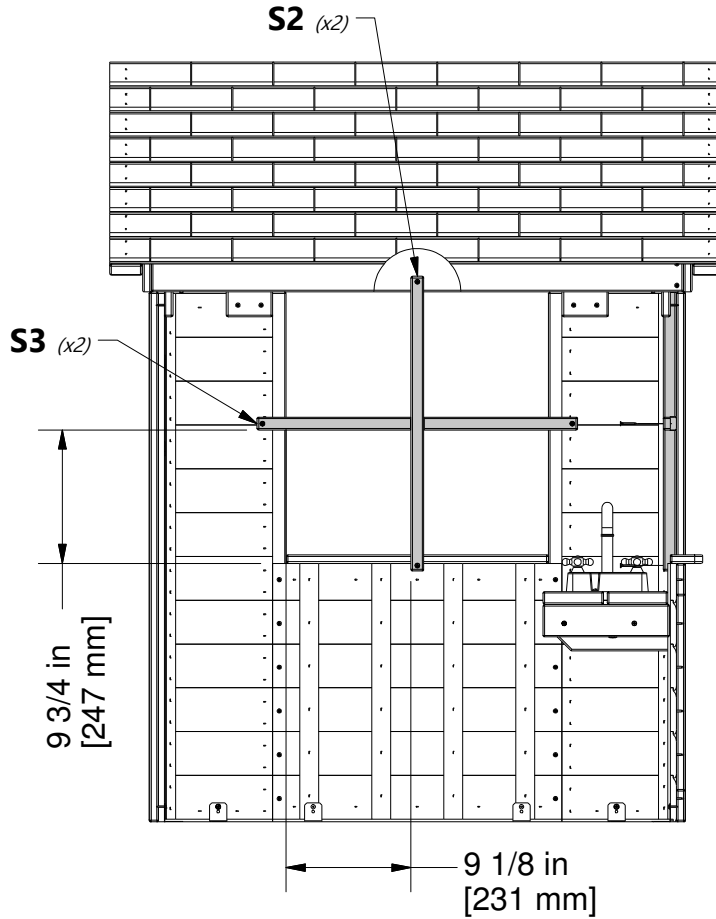
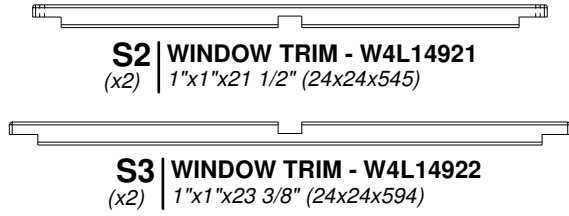

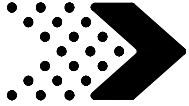

STOVE ASSEMBLY

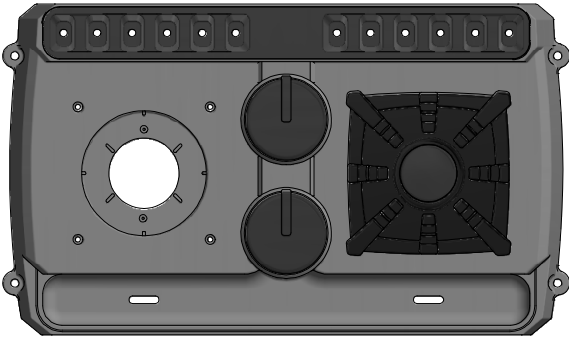

A6P00335 | **STOVE BASE**
(x1)



A6P00330 | **INDUCTIVE BURNER KIT**
(x1)

NOTE: FCC LABEL

- DO NOT MIX OLD AND NEW BATTERIES.
- DO NOT MIX ALKALINE, STANDARD (CARBON-ZINC), OR RECHARGEABLE (NI-CAD, NI-MH, ETC.) BATTERIES.
- NON-RECHARGEABLE BATTERIES ARE NOT TO BE RECHARGED.
- ONLY BATTERIES OF THE SAME OR EQUIVALENT TYPE AS RECOMMENDED ARE TO BE USED.
- BATTERIES ARE TO BE INSERTED WITH THE CORRECT POLARITY.
- EXHAUSTED BATTERIES ARE TO BE REMOVED FROM THE TOY OR IF THE TOY IS TO BE LEFT UNUSED FOR A LONG TIME.
- THE SUPPLY TERMINALS ARE NOT TO BE SHORT-CIRCUITED.
- RECHARGEABLE BATTERIES ARE TO BE REMOVED FROM THE TOY BEFORE BEING CHARGED.
- RECHARGEABLE BATTERIES ARE ONLY TO BE CHARGED UNDER ADULT SUPERVISION.

330 (x1)
INDUCTIVE BURNER KIT

"AA" BATTERY (x3)
(Not Included)

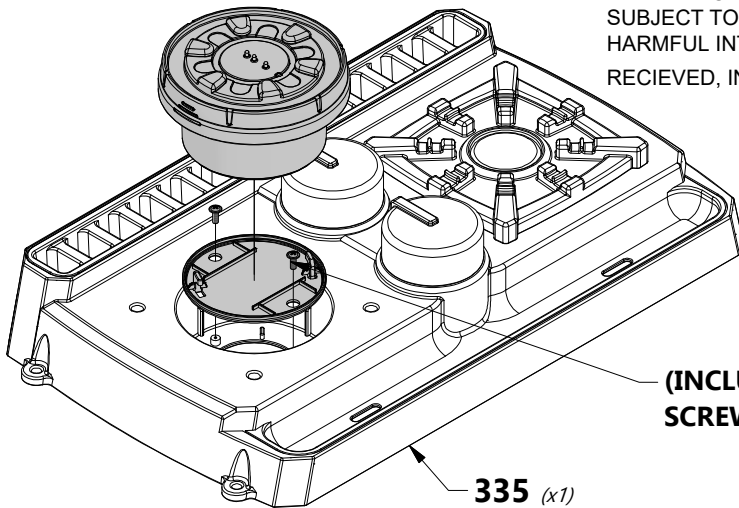

NOTE:
THIS DEVICE COMPLIES WITH PART 15 OF THE FCC RULES. OPERATION IS SUBJECT TO THE FOLLOWING TWO CONDITIONS: (1) THIS DEVICE MAY NOT CAUSE HARMFUL INTERFERENCE, (2) THIS DEVICE MUST ACCEPT ANY INTERFERENCE RECEIVED, INCLUDING INTERFERENCE THAT MAY CAUSE UNDESIRED OPERATION.

NOTE:
FIRST INSTALL THE COVER REMOVED ABOVE WITH THE INCLUDED HARDWARE. INSTALL THE BURNER BY TWISTING IT CLOCKWISE TO LOCK IT IN PLACE.

(INCLUDED WITH KIT) (x2)
SCREW PWH 4x5/16

335 (x1)
STOVE BASE

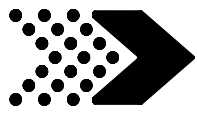

PLAYHOUSE ASSEMBLY

STEP 19

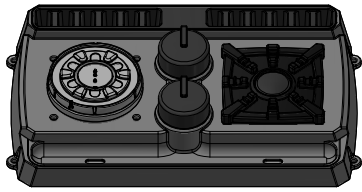

A6P00335 | STOVE BASE
(x1)



H100797 | SCREW PWH BLK
(x4) 8x1

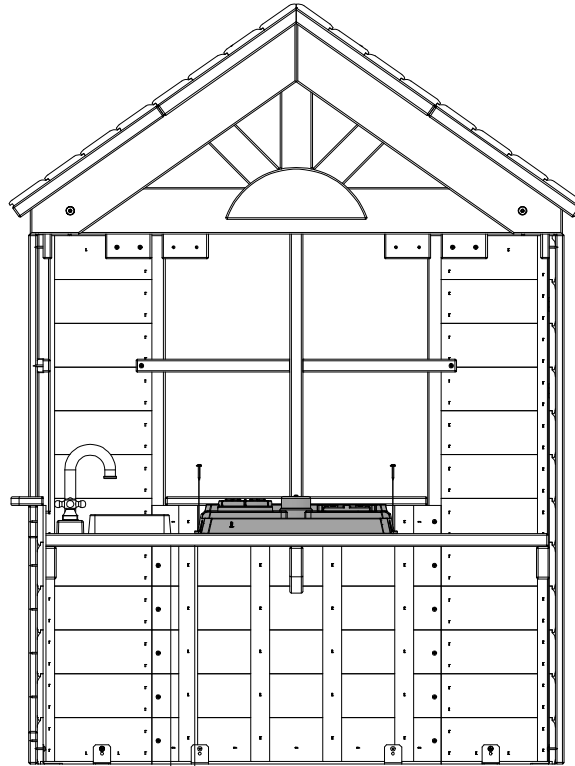

1 3/4 in
[45 mm]

335 (x1)
STOVE BASE

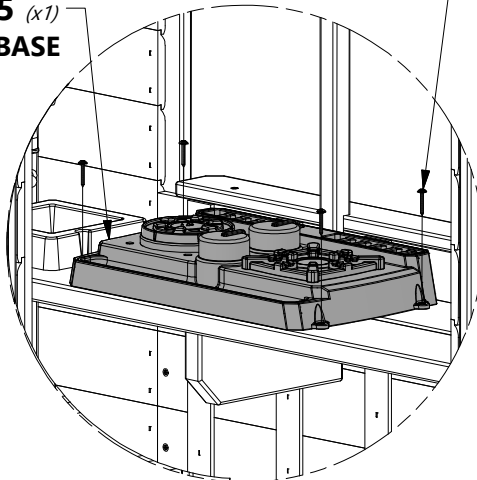

797 (x4)
SCREW - 1"

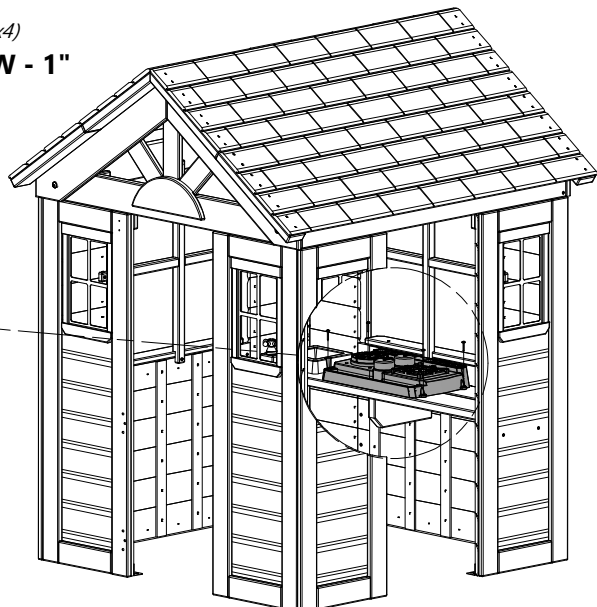

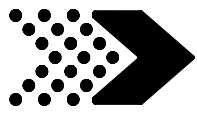

PLAYHOUSE ASSEMBLY

STEP 20

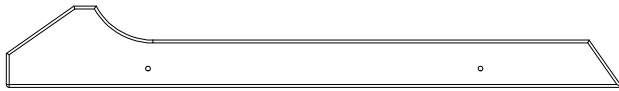

M33 | FASCIA BOARD - W4L14912
(x2) | 5/8"x3 3/8"x25 5/8" (16x86x652)



H100387 | SCREW PFH BLK
(x4) | 8x1 1/4

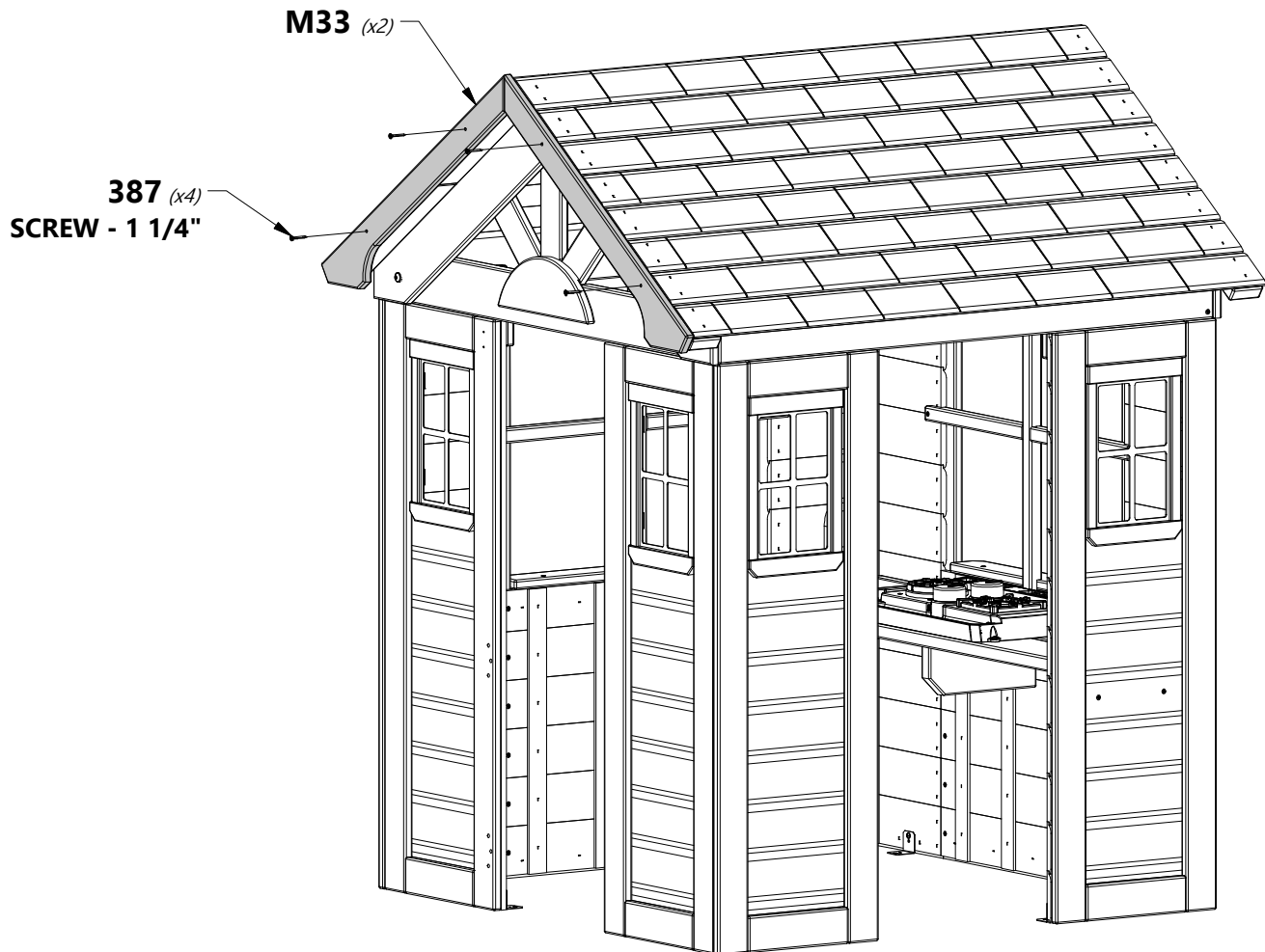

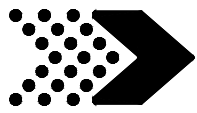

PLAYHOUSE ASSEMBLY

STEP 21

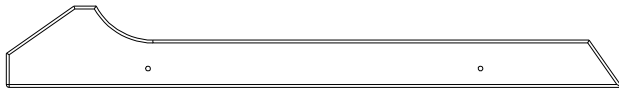

M33 | FASCIA BOARD - W4L14912
(x2) | 5/8"x3 3/8"x25 5/8" (16x86x652)



H100387 | SCREW PFH BLK
(x4) | 8x1-1/4

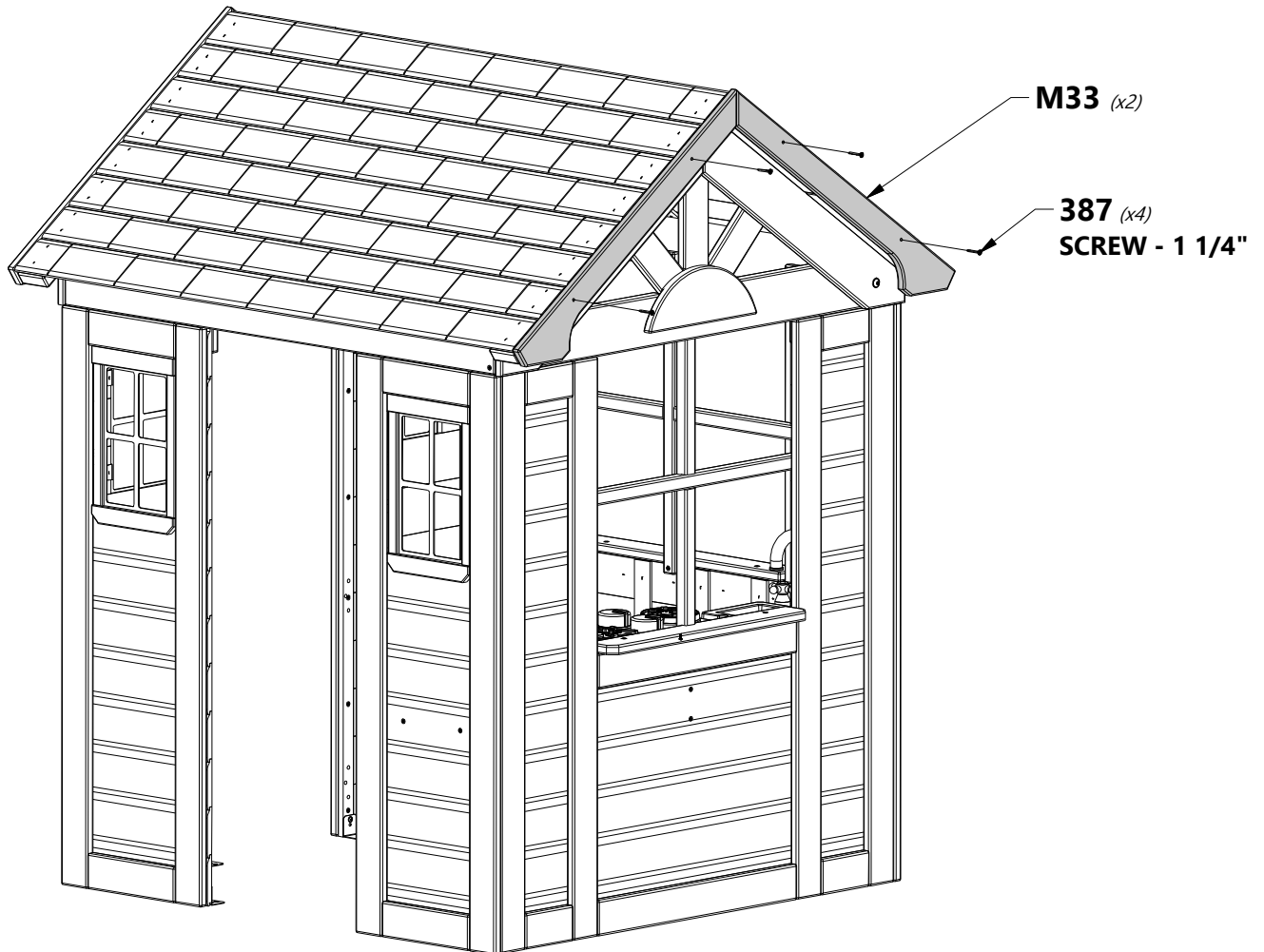

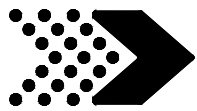

PLAYHOUSE ASSEMBLY

STEP 22

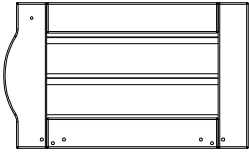

DP1 | DOOR PANEL - W2A03168
(x1) | 1 1/8"x19 1/8"x11 3/8" (27x486x288)



A6P00067 | KNOB - BLK
(x1)



A4M00933 | DOOR STOP
(x1)

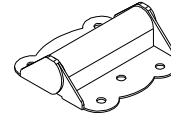

A4M00994 | HINGE (DOOR,
NON-SPRING
LOADED)
(x1)

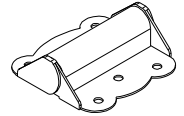

A4M00624 | HINGE (DOOR,
SPRING
LOADED)
(x1)



H100395 | SCREW PFH BLK
(x2) | 8x3/4



H100382 | SCREW PFH BLK
(x1) | 8x1 3/4



H100806 | SCREW POH BLK
(x6) | 8/32x1 1/8



H100804 | T-NUT
(x6) | 8/32

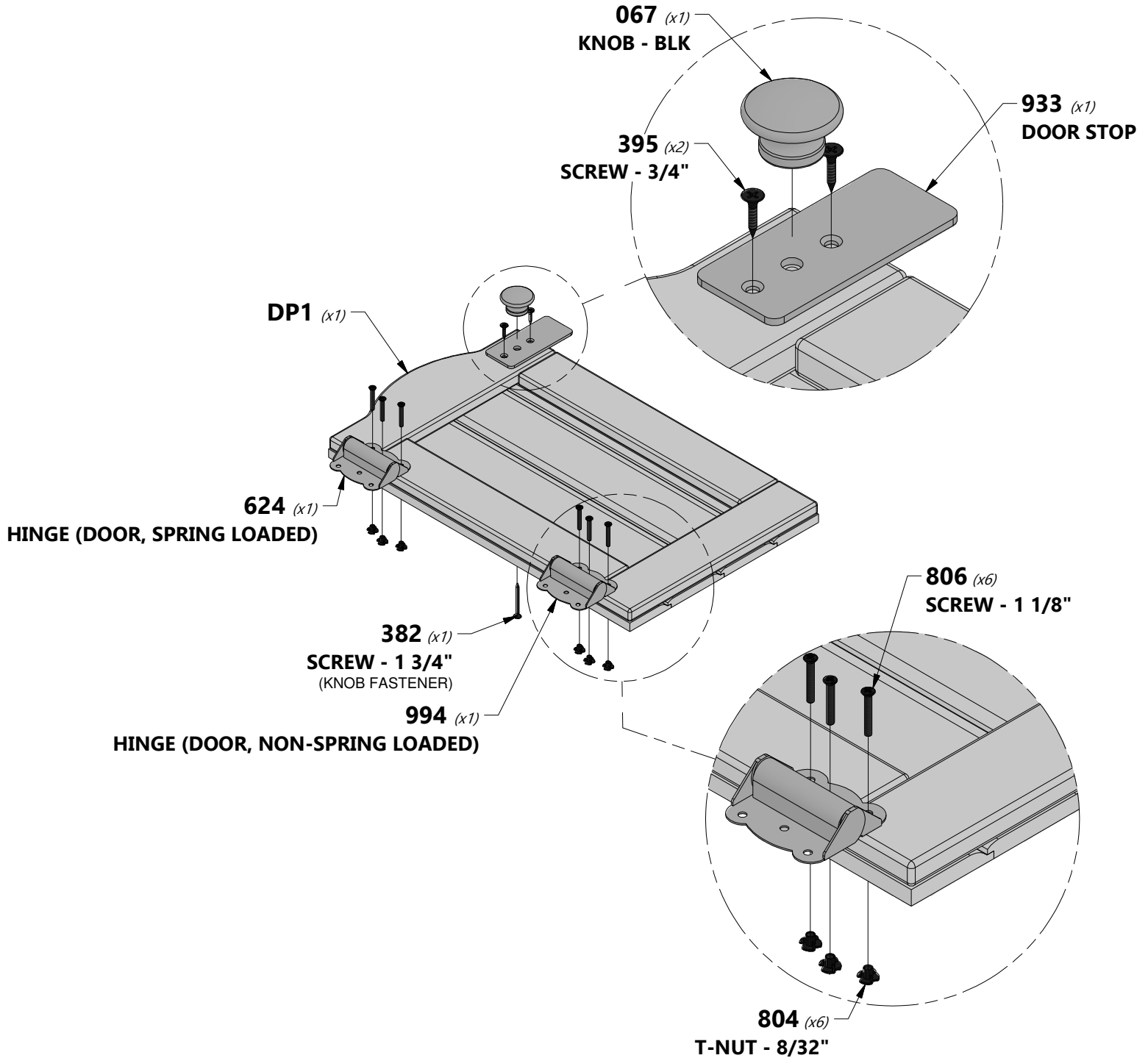

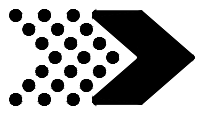

PLAYHOUSE ASSEMBLY

STEP 23

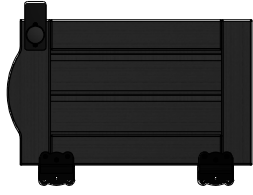

(x1) | DOOR SUBASSEMBLY



H100806 | SCREW POH BLK
(x6) | 8/32x1 1/8



H100804 | T-NUT
(x6) | 8/32

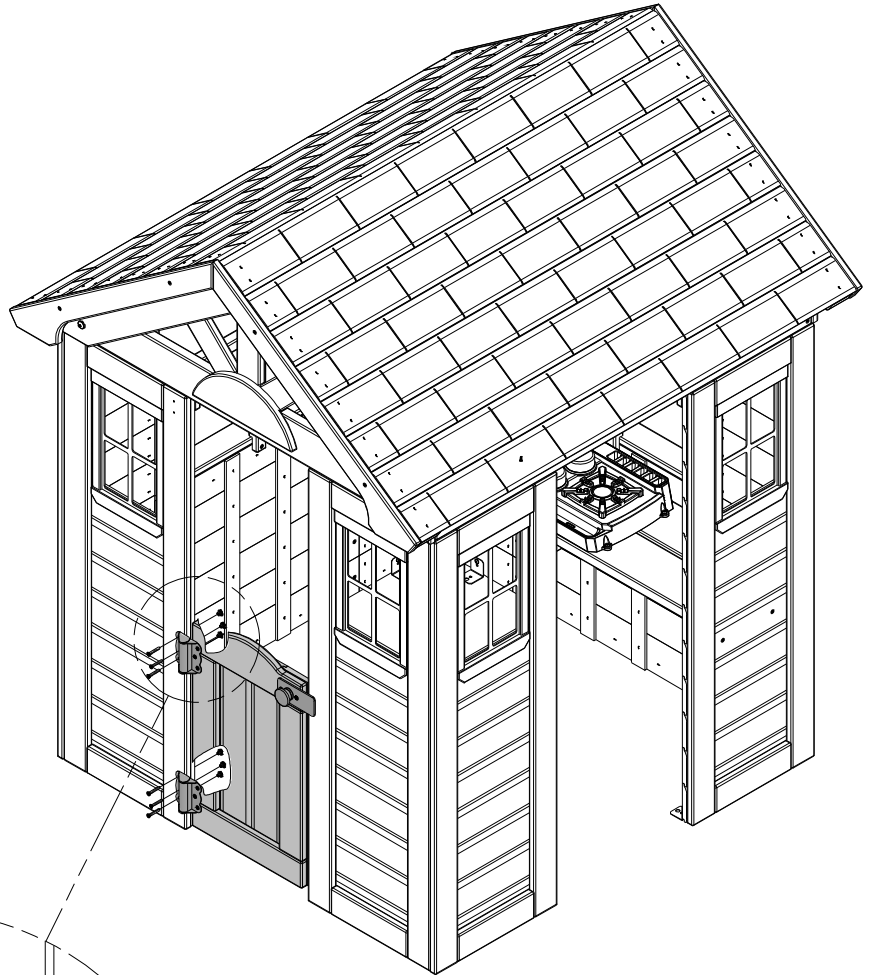

804 (x6)
T-NUT - 8/32"

806 (x6)
SCREW - 1 1/8"

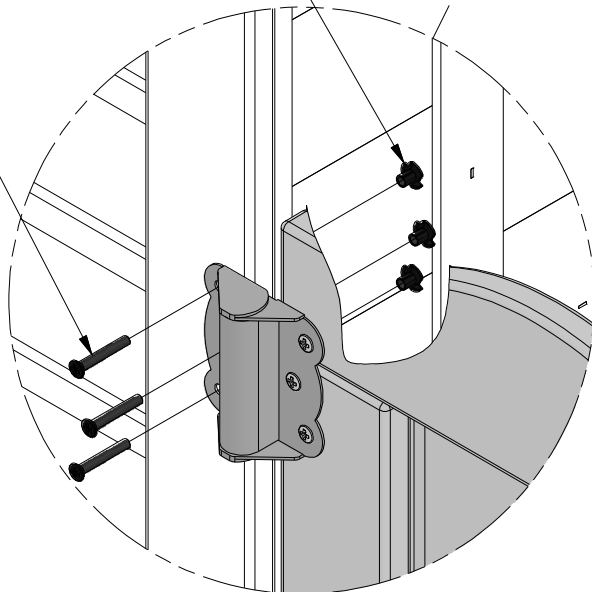

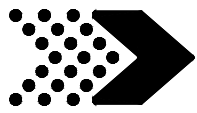

PLAYHOUSE ASSEMBLY

STEP 24



A4M01045 | BELL ASSEMBLY
(x1)



H100797 | SCREW PWH BLK
(x2) 8x1

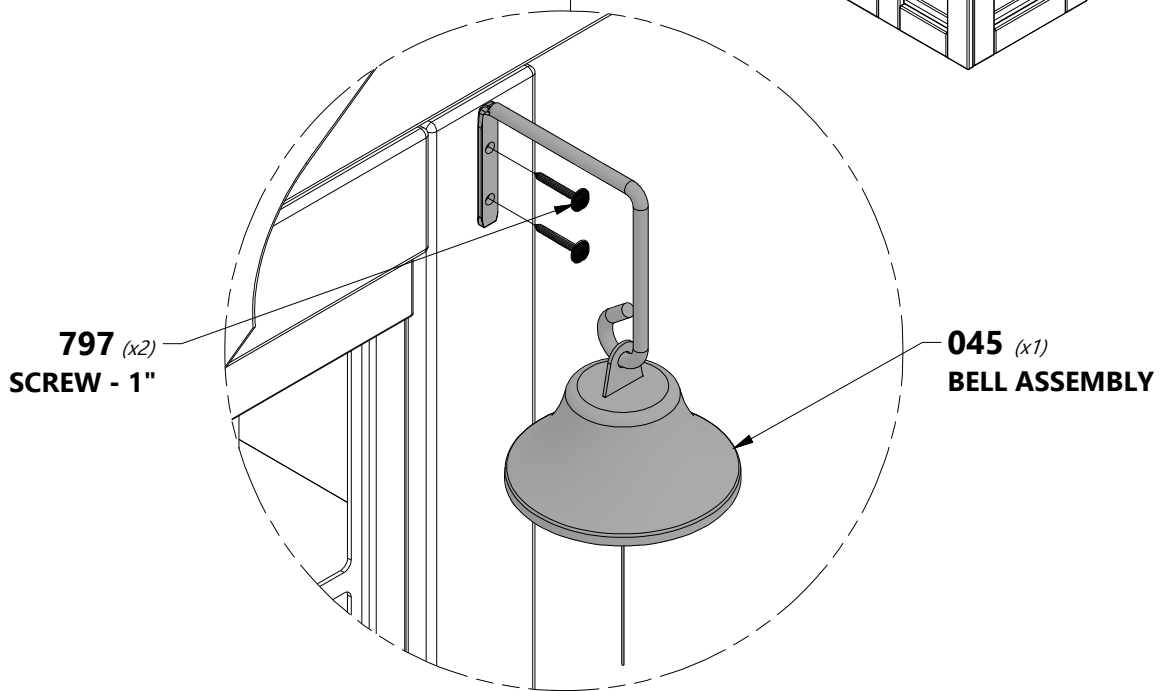
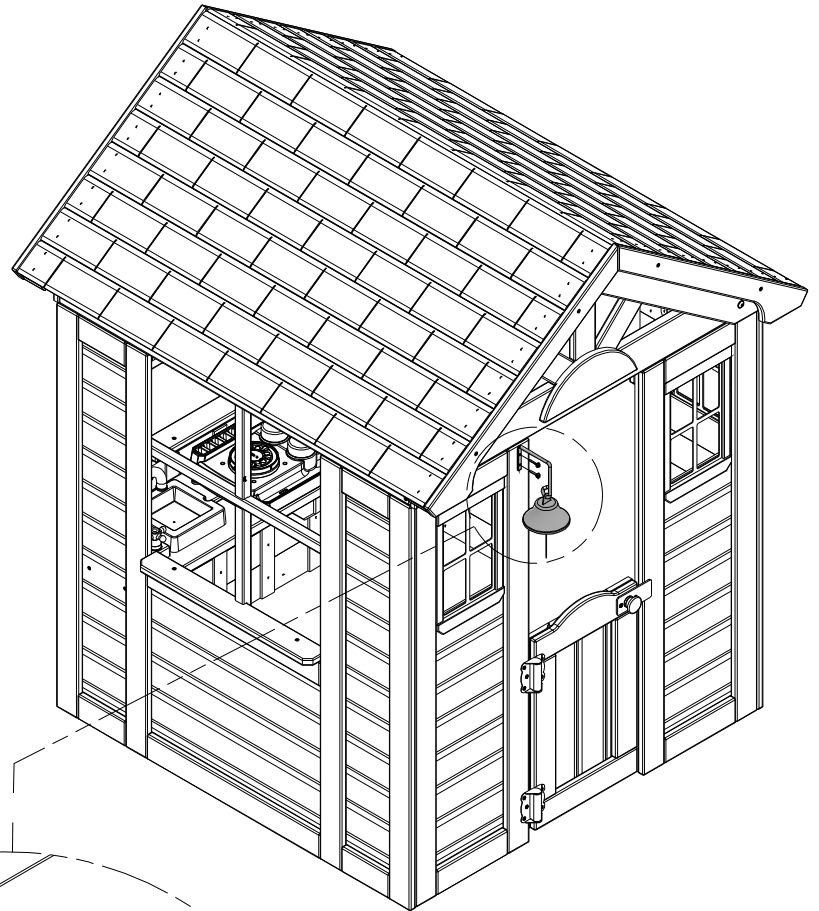

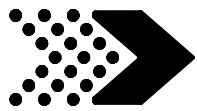

FINAL ASSEMBLY

STEP 1

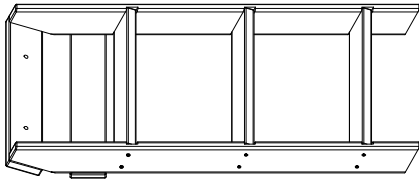

(x1)

LADDER SUBASSEMBLY



H100378 | BOLT WH BLK
(x2) | 5/16x1 3/4



H100198 | WASHER LOCK EXT BLK
(x2) | 8x19

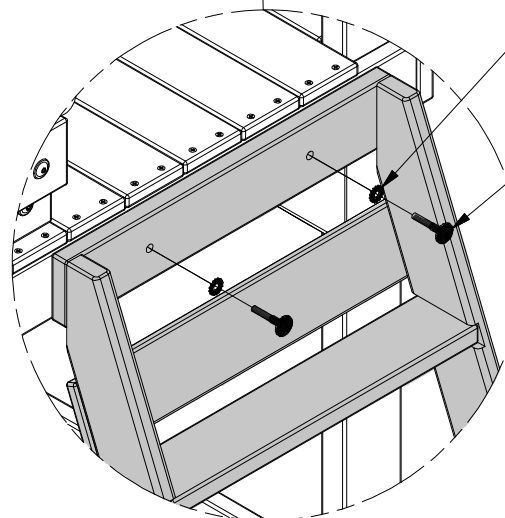
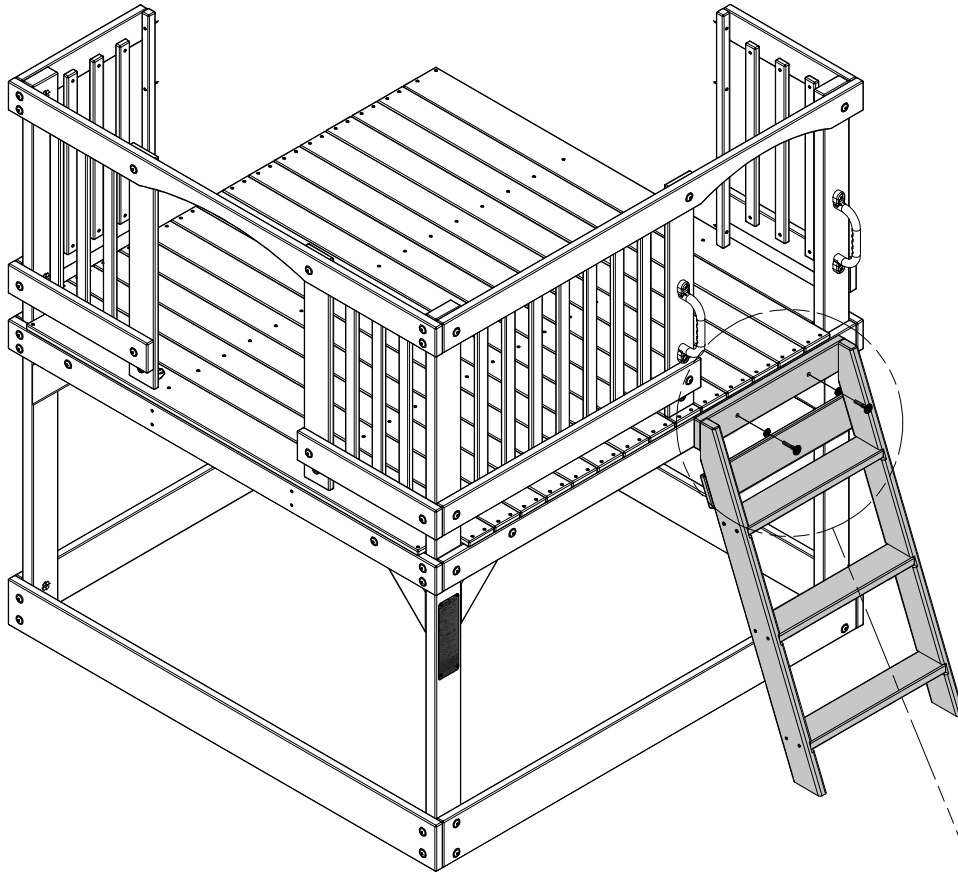

198 (x2)
WASHER - 8x19

378 (x2)
BOLT - 1 3/4"

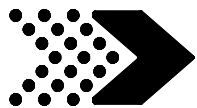

FINAL ASSEMBLY

STEP 2

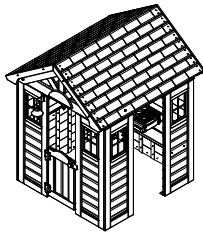

(x1)

PLAYHOUSE SUBASSEMBLY



H100382 | SCREW PFH BLK
(x8) | 8x1 3/4



H100408 | SCREW PWH BLK
(x8) | 8x1/2

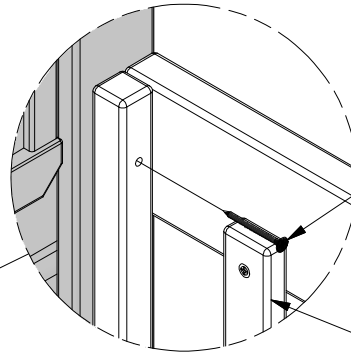
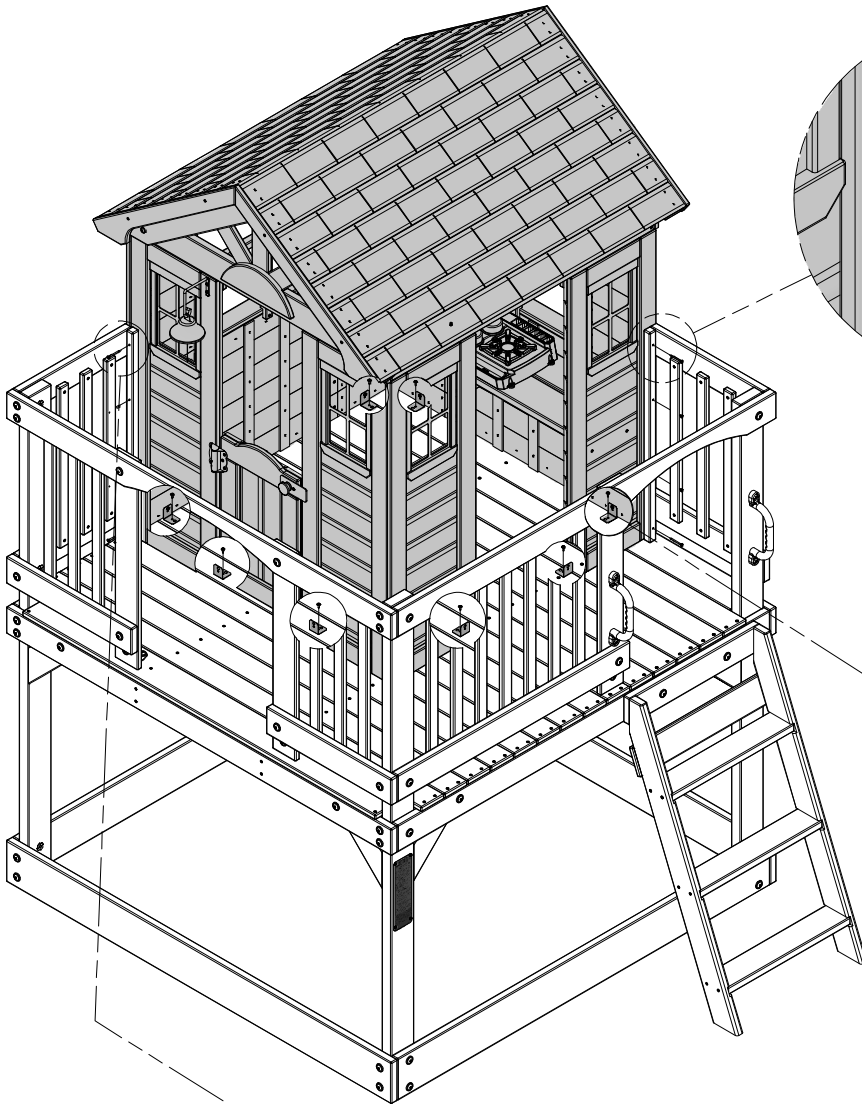

382 (x4)
SCREW - 1 3/4"



PICKET MAY NEED TO BE TEMPORARILY REMOVED TO ASSEMBLE THE HOUSE TO THE DECK.

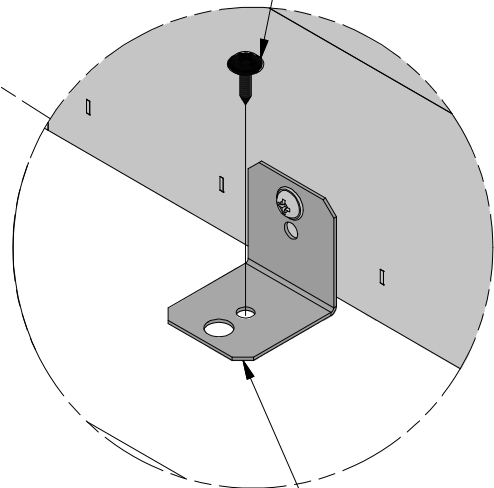

408 (x8)
SCREW - 1/2"

555
90° L-BRACKET - BLK
(ASSEMBLED PREVIOUSLY)

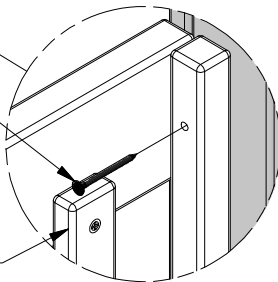

382 (x4)
SCREW - 1 3/4"



PICKET MAY NEED TO BE TEMPORARILY REMOVED TO ASSEMBLE THE HOUSE TO THE DECK.



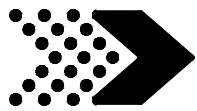

A4M00528 | **BYD ID TAG (MEDIUM) AGES 2 TO 10**
(x1)



H100202 | **SCREW PWH BLK**
(x2) 8x5/8

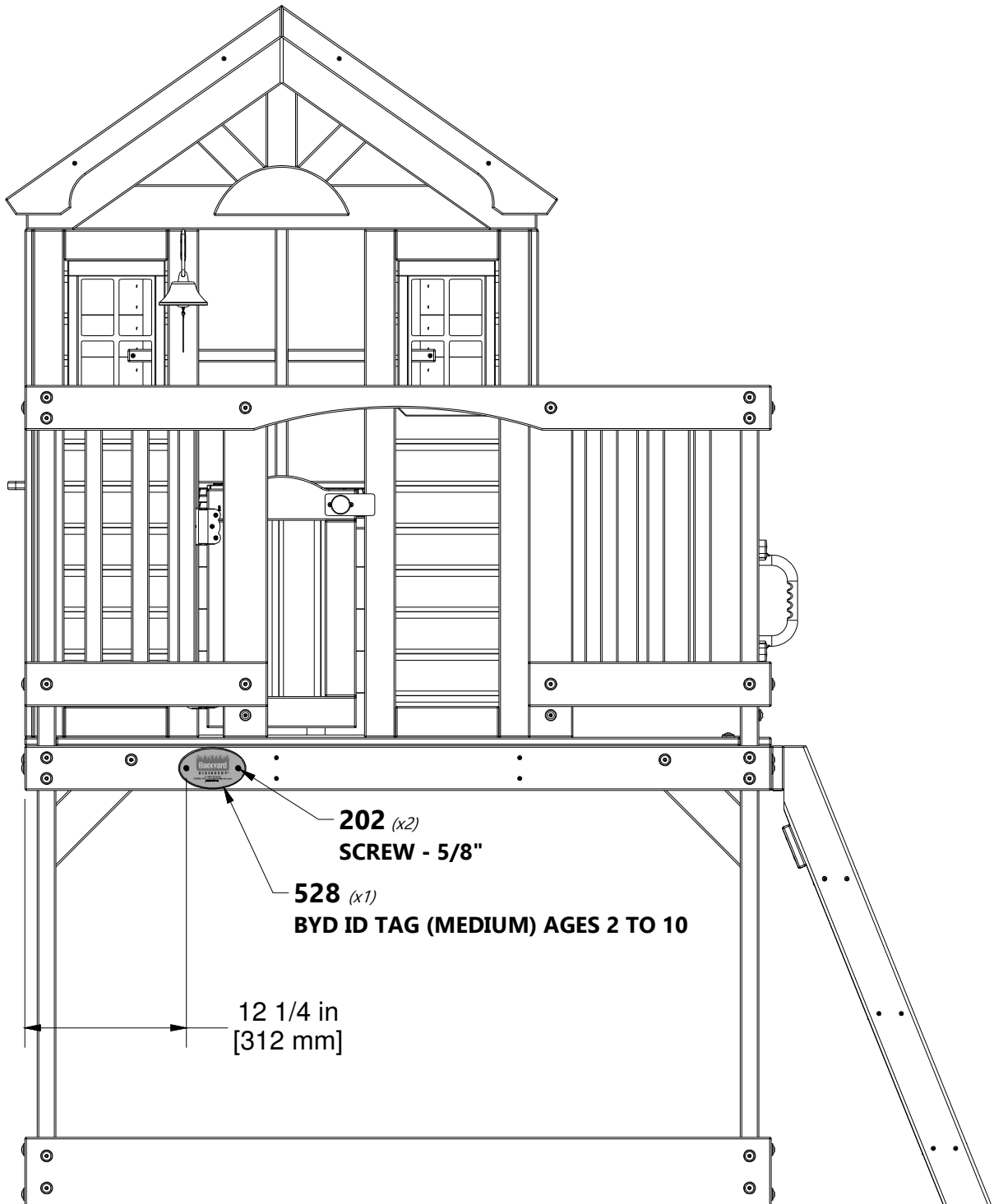

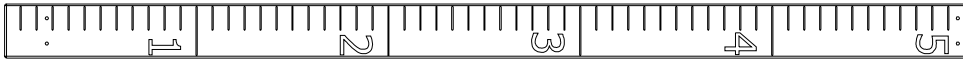
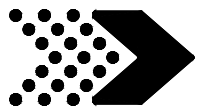

M1 | GROWTH BOARD - W4L14908
(x1) | 5/8"x3 3/8"x60 1/4" (16x86x1530)



H100380 | SCREW PFH BLK
(x4) | 8x1 1/8"

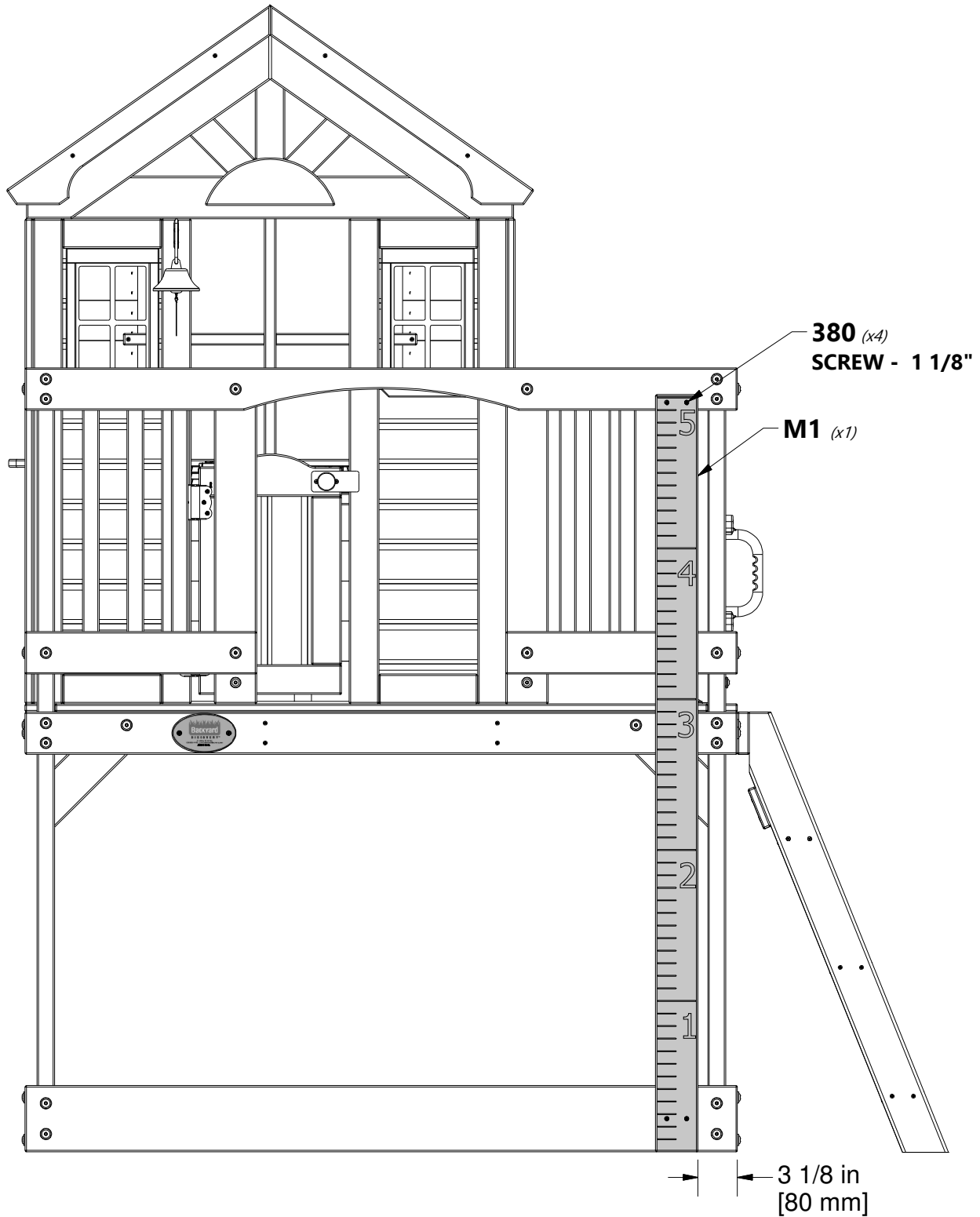

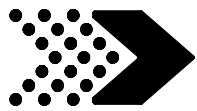

FINAL ASSEMBLY

STEP 5

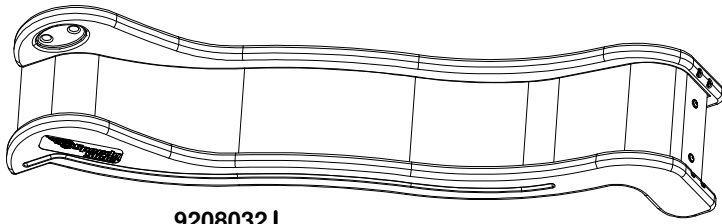

9208032 | 6 FT SPEEDY SLIDE
(x1)



H100396 | BOLT WH BLK
(x2) | 5/16x1/2



H100379 | T-NUT BLK
(x2) | 5/16

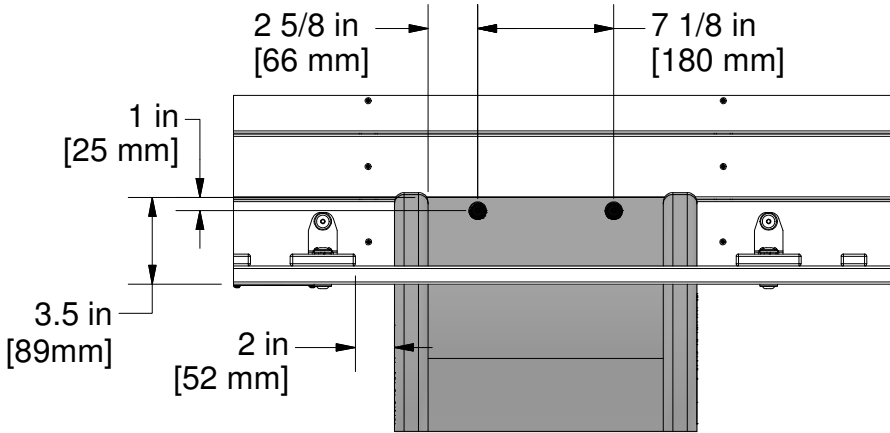

DRILLING LOCATIONS

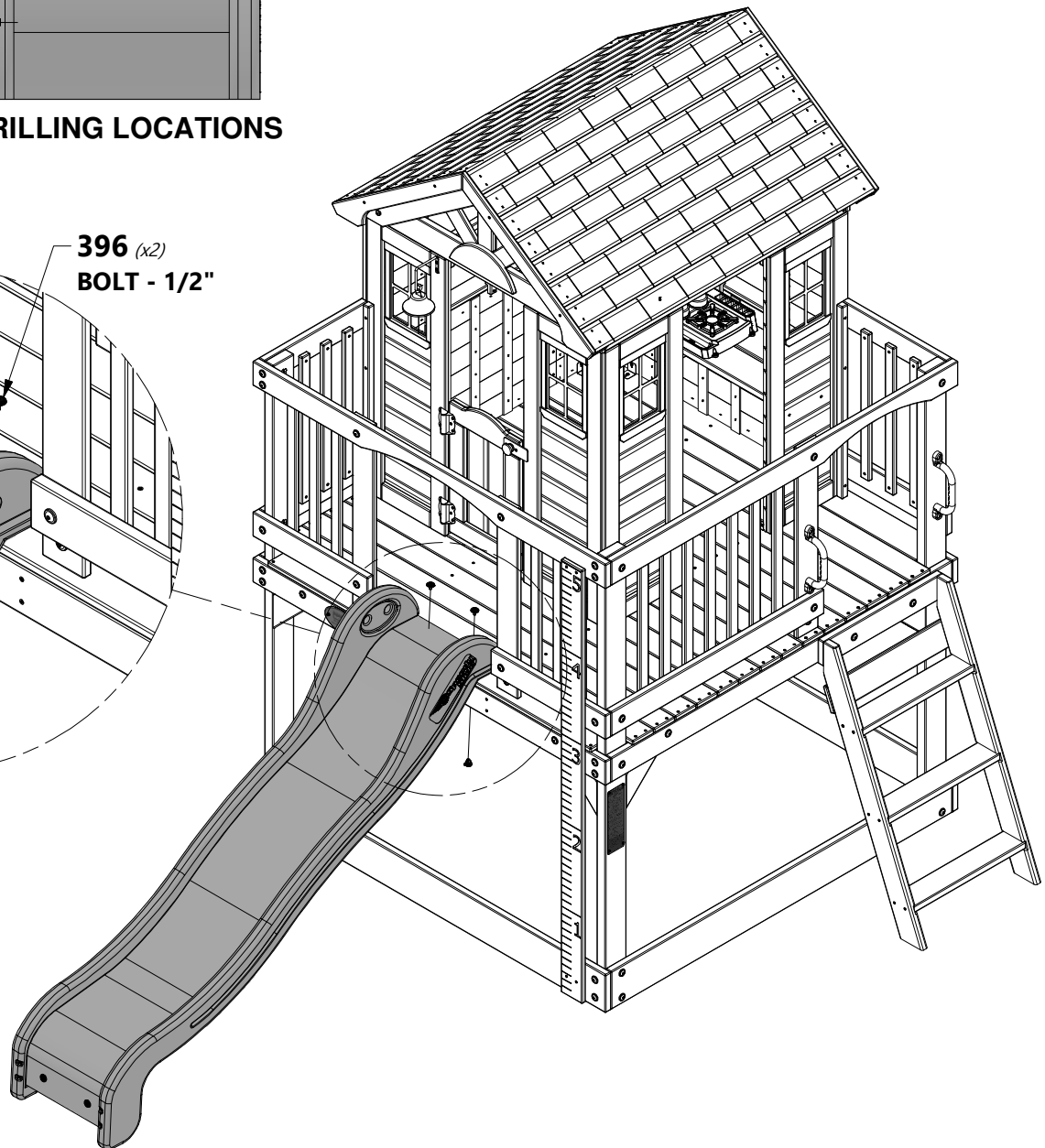
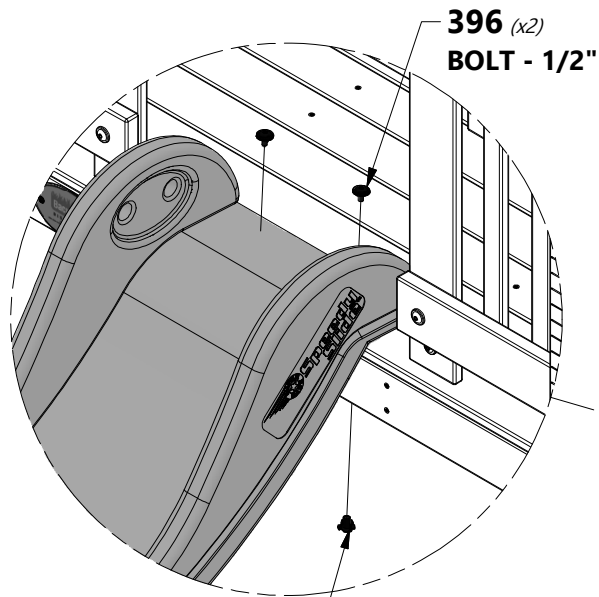
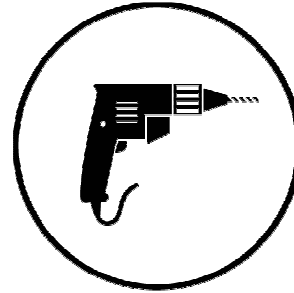

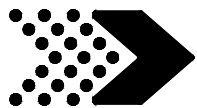

FINAL ASSEMBLY

STEP 6



A100178 | AUGER GROUND STAKE
(x4)



H100468 | BOLT WH BLK
(x4) 5/16x1



H100199 | WASHER LOCK EXT BLK
(x4) 12x19



H100469 | NUT BARREL WH BLK
(x4) 5/16x5/8



NOTE:
FAILURE TO USE GROUND
STAKES CAN VOID WARRANTY
& CAUSE INJURY!

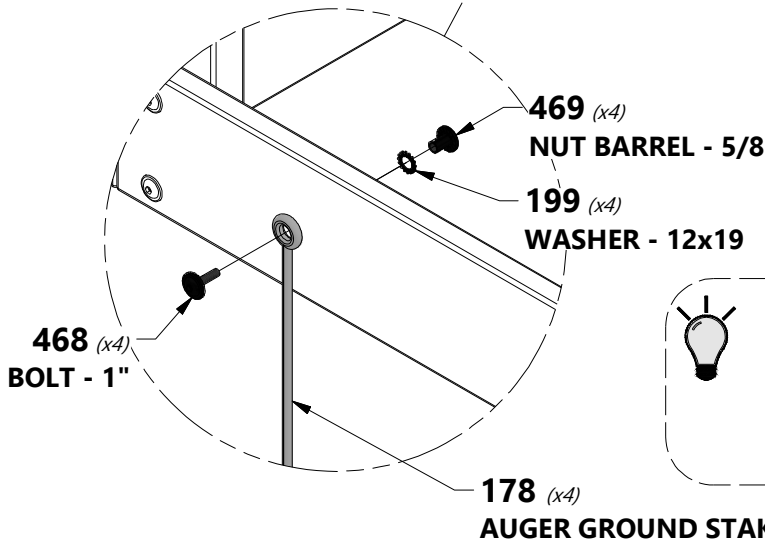
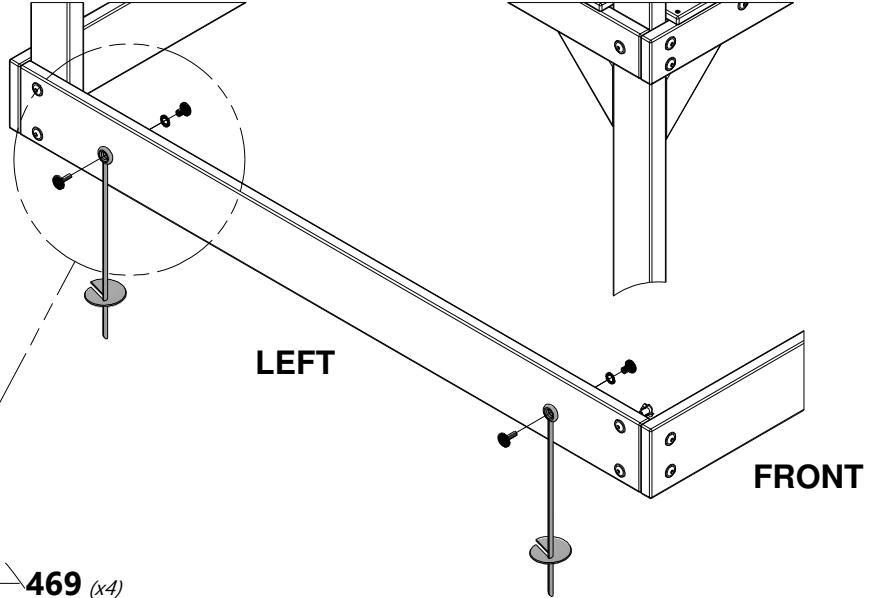
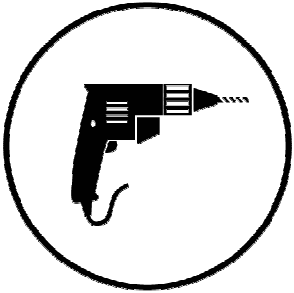

TIP:
TWIST GROUND STAKES INTO GROUND IN
LOCATIONS SHOWN.
USING GROUND STAKE AS A GUIDE, DRILL
7/16" HOLE FOR HARDWARE.

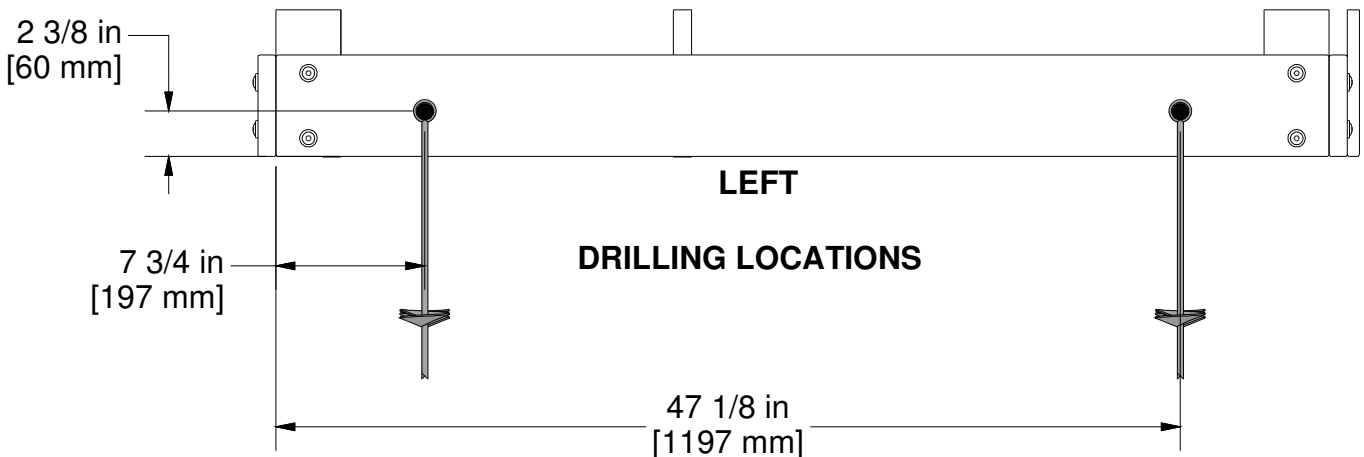

PERFORM THE SAME ASSEMBLY PROCESS FOR THE RIGHT SIDE.