

**PRODUCT SPECIFICATIONS**

Elkay ezH2O® Bottle Filling Station Surface Mount Non-Filtered Non-Refrigerated Stainless. Features shall include Antimicrobial\*, Green Ticker™, Hands Free, Laminar Flow, Real Drain. Electronic Bottle Filler Sensor activation. Product shall be Wall Mount (On Wall), for Indoor applications, serving 1 station(s). Unit shall be certified to UL 399 and CAN/CSA C22.2 No. 120.

<b>Special Features:</b>	Antimicrobial, Green Ticker™, Hands Free, Laminar Flow, Real Drain
<b>Finish:</b>	Stainless Steel
<b>Power:</b>	115V/60Hz
<b>Bubbler Style:</b>	No Bubbler
<b>Activation by:</b>	Electronic Bottle Filler Sensor
<b>Mounting Type:</b>	Wall Mount (On Wall)
<b>Chilling Capacity:</b>	Non-refrigerated
<b>Full Load Amps</b>	1
<b>Rated Watts:</b>	15
<b>Dimensions (L x W x H):</b>	17-15/16" x 8-3/16" x 25-7/16"
<b>Approx. Shipping Weight:</b>	32 lbs.
<b>Installation Location:</b>	Indoor
<b>No. of Stations Served:</b>	1

**Special Note: Able to pair with a remote chiller.**

- Green Ticker: Informs user of number of 20 oz. plastic water bottles saved from waste.
- Laminar flow provides clean fill with minimal splash.
- Key plastic components are manufactured with silver ion antimicrobial agent helping to provide clean, stain- and odor-free surfaces.
- Real Drain System eliminates standing water.

\*Antimicrobial claims are in reference to components manufactured antimicrobial agents, helping to provide clean, stain- and odor-free surfaces.



**Included with Product: Bottle Filler (EZWSSM)  
Ships in one box.**

A Century of Tradition and Quality. For more than 100 years, Elkay has been making innovative products and providing exceptional customer care. We take pride in offering plumbing products that make life easier, inspire change and leave the world a better place.



**PRODUCT COMPLIANCE**

- ADA & ICC A117.1
- CAN/CSA C22.2 No. 120
- GreenSpec®
- NSF/ANSI 61 (Q≤1) & 372 (lead free)
- UL 399



 Complies with ADA & ICC A117.1 accessibility requirements when installed according to the requirements outlined in these standards. Installation may require additional components and/or construction features to be fully compliant. Consult the local Authority Having Jurisdiction if necessary.

[Installation Instructions \(PDF\) - 200000494](#)

Electrical components and water system are warranted for 12 months from date of installation. **Warranty pertains to drinking water applications only. Non-drinking water applications are not covered under warranty.**

[Warranty \(PDF\)](#)

PART: \_\_\_\_\_ QTY: \_\_\_\_\_

PROJECT: \_\_\_\_\_



CONTACT: \_\_\_\_\_

DATE: \_\_\_\_\_

NOTES: \_\_\_\_\_

APPROVAL: \_\_\_\_\_

*In keeping with our policy of continuing product improvement, Elkay reserves the right to change product specifications without notice. Please visit elkay.com for the most current version of Elkay product specification sheets. This specification describes an Elkay product with design, quality, and functional benefits to the user. When making a comparison of other producers' offerings, be certain these features are not overlooked.*

Optional Accessories		
<a href="#">EWF3000</a>	Elkay <sup>®</sup> Universal Filtration Kit (3000-Gallon) <a href="#">Spec Sheet (PDF)</a>	
<a href="#">ECH8</a>	Elkay Remote Chiller Non-Filtered Refrigerated 8 GPH <a href="#">Spec Sheet (PDF)</a>	

*In keeping with our policy of continuing product improvement, Elkay reserves the right to change product specifications without notice. Please visit [elkay.com](http://elkay.com) for the most current version of Elkay product specification sheets. This specification describes an Elkay product with design, quality, and functional benefits to the user. When making a comparison of other producers' offerings, be certain these features are not overlooked.*

OPERATION OF QUICK CONNECT FITTINGS

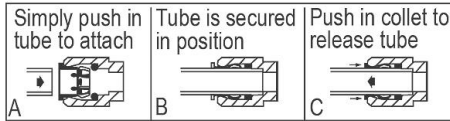

Pushing tube in before pulling it out helps to release tube

**IMPORTANT!**  
**INSTALLATION NOTES :**

Ensure wall is structurally sound to bear the loads imparted by the surface mount bottle filler.

**ELECTRICAL**

Equipped with electrical cord and three-prong molded rubber plug for use with 15-amp minimum receptacle. Rated at 115V/60Hz, single phase.

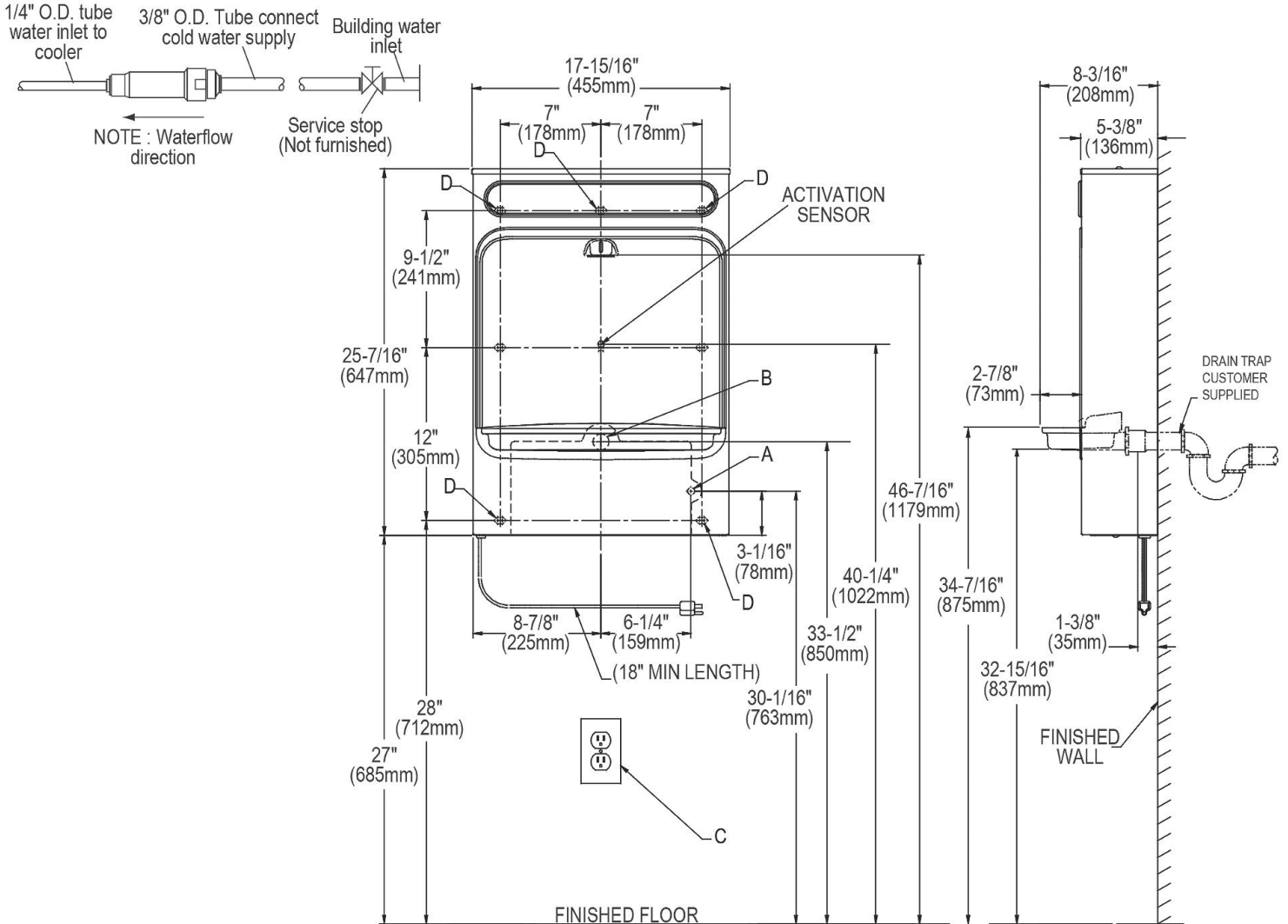

LEGEND :

A = Recommended water supply location; 1/2" I.P.S. maximum pipe size. Service stop valve not furnished.

B = Recommended location for waste outlet 1-1/4" O.D. maximum pipe size.

C = Electrical outlet, three (3) conductor grounded. Locate within safe reach of power cord.

D = 7/16" X 3/4" orbound mounting holes for fastening backplate to wall.

NOTE : New Installations Must Use Ground Fault Circuit Interrupter (GFCI). It is highly recommended that the circuit be dedicated and the load protection be sized for 20 amps.

In keeping with our policy of continuing product improvement, Elkay reserves the right to change product specifications without notice. Please visit [elkay.com](http://elkay.com) for the most current version of Elkay product specification sheets. This specification describes an Elkay product with design, quality, and functional benefits to the user. When making a comparison of other producers' offerings, be certain these features are not overlooked.