

# F29370

# BEAR CAVE LODGE

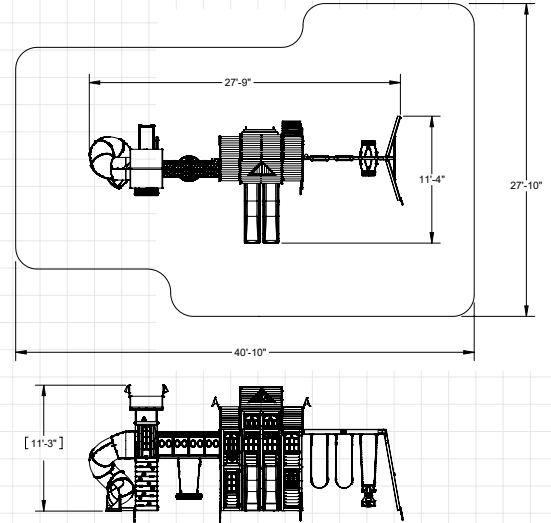


**OBSTACLE FREE SAFETY ZONE** - 40' 10" x 27' 10" x 17' 3" area requires Protective Surfacing. See page 4.

**MAXIMUM VERTICAL FALL HEIGHT** - 6' 9".

**CAPACITY** - 14 Users Maximum, Ages 3 to 10; Weight Limit 110 lbs. (50 kg) per child.

**RESIDENTIAL HOME USE ONLY.** Not intended for public areas such as multi-unit residences, schools, churches, nurseries, day cares or parks.



## INSTALLATION AND OPERATING INSTRUCTIONS

### FOR 24/7 ONLINE PARTS REPLACEMENT

[parts.kidkraft.com](http://parts.kidkraft.com)

KidKraft, Inc.  
4630 Olin Road  
Dallas, Texas 75244  
USA

[customerservice@kidkraft.com](mailto:customerservice@kidkraft.com)

1.800.933.0771  
972.385.0100

[parts.kidkraft.eu](http://parts.kidkraft.eu)

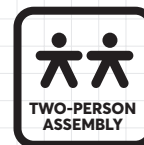
KidKraft Netherlands BV  
Olympisch Stadion 8  
1076 DE Amsterdam  
The Netherlands

[europcustomerservice@kidkraft.com](mailto:europcustomerservice@kidkraft.com)

+31 20 305 8620  
M-F from 09:00 to 17:30 (GMT+1)

9409370

Rev 10/11/2022



### ⚠️ WARNING

To reduce the risk of serious injury or death, please read and follow these instructions. Keep and refer to instructions as needed and pass along to any future owners of this item.

## **Congratulations on purchasing a KidKraft product!**

**Our items are made of high-quality,  
durable Cunninghamia Lanceolata wood  
from the cypress family.**

**Lumber from these trees are known for  
their light weight and excellent strength.  
The porosity of this wood allows the  
moisture to absorb and evaporate in the  
fibers, resisting rot and bugs.**

**Engineered for great play, our products  
also go through extensive testing for safety.**

**Plus, our team has developed a series of  
proprietary methods for a simpler, more  
organized assembly. Less build time and  
more play time is our motto!**

**However, during assembly if you have any  
questions or concerns, please reach out.  
Our Customer Service can help with missing  
parts, instructions or maintenance.**



## Warnings and Safe Play Instructions



**CONTINUOUS ADULT SUPERVISION REQUIRED.** Most serious injuries and deaths on playground equipment have occurred while children were unsupervised! Our products are designed to meet mandatory and voluntary safety standards. Complying with all warnings and recommendations in these instructions will reduce the risk of serious or fatal injury to children using this play system. Go over the warnings and safe play instructions regularly with your children and make certain that they understand and follow them. Remember on-site adult supervision is required for children of all ages.



### WARNING

#### SERIOUS HEAD INJURY HAZARD

Installation over concrete, asphalt, dirt, grass, carpet and other hard surface creates a risk of serious injury or death from falls to the ground. Install and maintain shock absorbing material under and around play-set as recommended on page 4 of these instructions.

#### COLLISION HAZARD

Place play-set on level ground at least 2m from any obstruction such as a garage or house, fences, poles, trees, sidewalks, walls, landscape timbers, rocks, pavement, planters, garden borders, overhanging branches, laundry lines, and electrical wires. (See OBSTACLE FREE SAFETY ZONE on cover)

#### CHOKING HAZARD/SHARP EDGES & POINTS

Adult assembly required. This product contains small parts and parts with sharp edges and points. Keep parts away from children until fully assembled.

#### WARNING LABEL

Owners shall be responsible for maintaining the legibility of the warning labels.

#### STRANGULATION HAZARD

- NEVER allow children to play with ropes, clotheslines, pet leashes, cables, chains or cord-like items when using this play-set or to attach these items to play-set.
- NEVER allow children to wear loose fitting clothing, ponchos, hoods, scarves, capes, necklaces, items with draw-strings, cords or ties when using this play-set.
- NEVER allow children to wear bike or sport helmets when using this play-set.

Failure to prohibit these items, even helmets with chin straps, increases the risk of serious injury and death to children from entanglement and strangulation.

#### TIP OVER HAZARD

Choose a level location for the equipment. This can reduce the likelihood of the play set tipping over and loose-fill surfacing materials washing away during heavy rains.

DO NOT allow children to play on the play-set until the assembly is complete and the unit is properly anchored.

Never add extra length to chain or rope. The chains or ropes provided are the maximum length designed for the swinging element(s).



## WARNING – Safe Play Instructions

- ✓ Observe capacity limitations of your play-set. See front cover.
- ✓ Dress children with well fitting and full foot enclosing footwear.
- ✓ Teach children to sit with their full weight in the center of the swing seat to prevent erratic swing motion or falling off.
- ✓ Check for splintered, broken or cracked wood; missing, loose, or sharp edged hardware. Replace, tighten and or sand smooth as required prior to playing.
- ✓ Verify that suspended climbing ropes, rope ladders, chain or cable are secured at both ends and cannot be looped back on itself as to create an entanglement hazard.
- ✓ On sunny and or hot days, check the slide and other plastic rides to assure that they are not very hot as to cause burns. Cool hot slide and rides with water and wipe dry prior to using.
- ✓ Orientate slide such that it gets the least amount of exposure to the sun.
- ✗ Do not allow children to wear open toe or heel footwear like sandals, flip-flops or clogs.
- ✗ Do not allow children to walk, in front, between, behind or close to moving rides.
- ✗ Do not let children twist swing chains or ropes or loop them over the top support bar. This may reduce the strength of the chain or rope and cause premature failure.
- ✗ Do not let children get off rides while they are in motion.
- ✗ Do not permit climbing on equipment when it is wet.
- ✗ Do not permit rough play or use of equipment in a manner for which it was not intended. Standing on or jumping from the roof, elevated platforms, swings, climbers, ladders or slide can be dangerous.
- ✗ Do not allow children to swing empty rides or seats.
- ✗ Do not allow children to go down slide head first or run up slide.

# ⚠️ Protective Surfacing - Reducing Risk of Serious Head Injury From Falls

One of the most important things you can do to reduce the likelihood of serious head injuries is to install shock-absorbing protective surfacing under and around your play equipment. The protective surfacing should be applied to a depth that is suitable for the equipment height in accordance with ASTM F1292. There are different types of surfacing to choose from; whichever product you select, follow these guidelines:

## Loose-Fill Materials

- Maintain a minimum depth of 9 inches (23 cm) of loose-fill materials such as wood mulch/chips, engineered wood fiber (EWF), or shredded/recycled rubber mulch for equipment up to 8 feet (2,45 m) high; and 9 inches (23 cm) of sand or pea gravel for equipment up to 5 feet (1,5 m) high. NOTE: An initial fill level of 12 inches (31 cm) will compress to about a 9-inch (23 cm) depth of surfacing over time. The surfacing will also compact, displace, and settle, and should be periodically raked and refilled to maintain at least a 9-inch (23 cm) depth.
- Use a minimum of 6 inches (16 cm) of protective surfacing for play equipment less than 4 feet (1,22 m) in height. If maintained properly, this should be adequate. (At depths less than 6 inches (16 cm), the protective material is too easily displaced or compacted.)

NOTE: Do not install home playground equipment over concrete, asphalt, or any other hard surface. A fall onto a hard surface can result in serious injury to the equipment user. Grass and dirt are not considered protective surfacing because wear and environmental factors can reduce their shock absorbing effectiveness. Carpeting and thin mats are not adequate protective surfacing. Ground level equipment -- such as a sandbox, activity wall, playhouse or other equipment that has no elevated play surface -- does not need any protective surfacing.

- Use containment, such as digging out around the perimeter and/or lining the perimeter with landscape edging. Don't forget to account for water drainage.
- Periodically rake, check and maintain the depth of the loose-fill surfacing material. Marking the correct depth on the play equipment support posts will help you to see when the material has settled and needs to be raked and or replenished. Be sure to rake and evenly redistribute the surfacing in heavily used areas.
- Do not install loose fill surfacing over hard surfaces such as concrete or asphalt.

## Poured-In-Place Surfaces or Pre-Manufactured Rubber Tiles

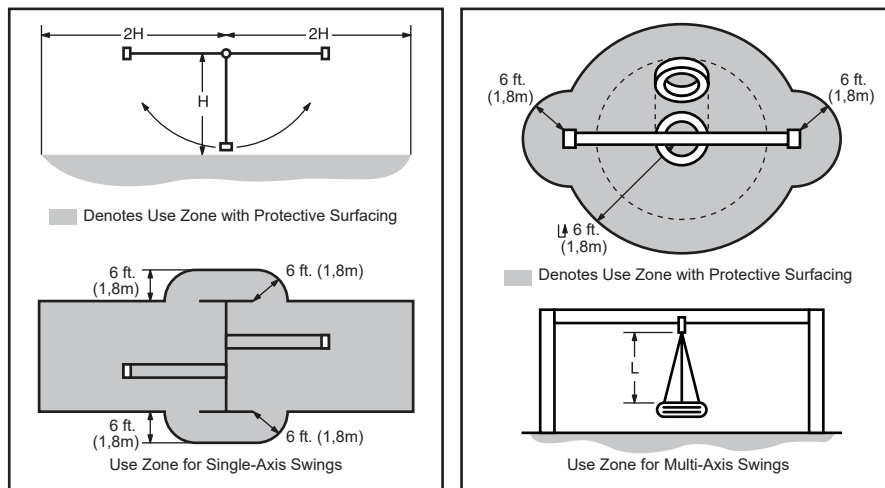
You may be interested in using surfacing other than loose-fill materials - like rubber tiles or poured-in-place surfaces.

- Installations of these surfaces generally require a professional and are not “do-it yourself” projects.
- Review surface specifications before purchasing this type of surfacing. Ask the installer/manufacturer for a report showing that the product has been tested to the following safety standard: ASTM F1292 *Standard Specification for Impact Attenuation of Surfacing Materials within the Use Zone of Playground Equipment*. This report should show the specific height for which the surface is intended to protect against serious head injury. This height should be equal to or greater than the fall height - vertical distance between a designated play surface (*elevated surface for standing, sitting, or climbing*) and the protective surfacing below - of your play equipment.
- Check the protective surfacing frequently for wear.

## Placement

Proper placement and maintenance of protective surfacing is essential. Refer to diagram on front cover. Be sure to;

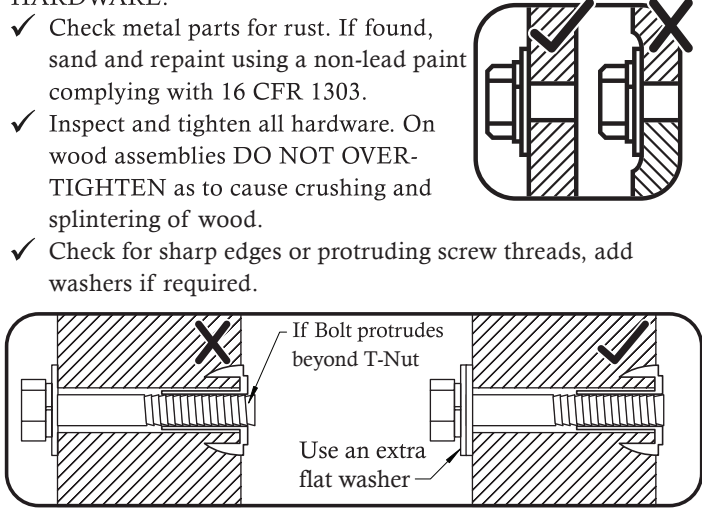
- Extend surfacing at least 6 feet (1,8 m) from the equipment in all directions.
- For to-fro swings, extend protective surfacing in front of and behind the swing to a distance equal to twice the height of the top bar from which the swing is suspended.
- For tire swings, extend surfacing in a circle whose radius is equal to the height of the suspending chain or rope, plus 6 feet (1,8 m) in all directions.



# Instructions for Proper Maintenance

Your KidKraft Play System is designed and constructed of quality materials with your child's safety in mind. As with all outdoor products used by children, it will weather and wear. To maximize the enjoyment, safety and life of your Play Set, it is important that you, the owner, properly maintain it.

## Check the following at the beginning of the play season:

<p><b>HARDWARE:</b></p> <ul style="list-style-type: none"> <li>✓ Check metal parts for rust. If found, sand and repaint using a non-lead paint complying with 16 CFR 1303.</li> <li>✓ Inspect and tighten all hardware. On wood assemblies <b>DO NOT OVER-TIGHTEN</b> as to cause crushing and splintering of wood.</li> <li>✓ Check for sharp edges or protruding screw threads, add washers if required.</li> </ul>  <p><b>SHOCK ABSORBING SURFACING:</b></p> <ul style="list-style-type: none"> <li>✓ Check for foreign objects. Rake and check depth of loose fill protective surfacing materials to prevent compaction and maintain appropriate depth. Replace as necessary. (See Protective Surfacing, page 4)</li> </ul>	<p><b>GROUND STAKES (ANCHORS):</b></p> <ul style="list-style-type: none"> <li>✓ Check for looseness, damage or deterioration. Should firmly anchor unit to ground during use. Re-secure and or replace, if necessary.</li> </ul> <p><b>SWING HANGERS:</b></p> <ul style="list-style-type: none"> <li>✓ Check that bolts are secure and tight. Quick clips should be completely closed and threaded clips screwed tight.</li> <li>✓ If squeaking occurs lubricate bushings with oil or WD-40®.</li> </ul> <p><b>SWINGS, ROPES AND RIDES:</b></p> <ul style="list-style-type: none"> <li>✓ Reinstall if removed during cold season. Check all moving parts including swing seats, ropes, chains and attachments for wear, rust and other deterioration. Replace as needed.</li> <li>✓ Check that ropes are tight, secure at both ends and cannot loop back as to create an entrapment.</li> </ul> <p><b>WOOD PARTS:</b></p> <ul style="list-style-type: none"> <li>✓ Check all wood members for deterioration, structural damage and splintering. Sand down splinters and replace deteriorated wood members. As with all wood, some checking and small cracks in grain is normal.</li> <li>✓ Applying a water repellent or stain (water-based) on a yearly basis is important maintenance to maintain maximum life and performance of the product.</li> </ul>
--	---

## Check twice a month during play season:

<p><b>HARDWARE:</b></p> <ul style="list-style-type: none"> <li>✓ Inspect for tightness. Must be firmly against, but not crushing the wood. <b>DO NOT OVER-TIGHTEN.</b> This will cause splintering of wood.</li> <li>✓ Check for sharp edges or protruding screw threads. Add washers if required.</li> </ul>	<p><b>SHOCK ABSORBING SURFACING:</b></p> <ul style="list-style-type: none"> <li>✓ Rake and check depth of loose fill protective surfacing materials to prevent compaction and maintain appropriate depth. Replace as necessary. (See Protective Surfacing, page 4)</li> </ul>
---	---

## Check once a month during play season:

<p><b>SWING HANGERS:</b></p> <ul style="list-style-type: none"> <li>✓ Check that they are secure and orientated correctly. Hook should rotate freely and perpendicular to support beam.</li> <li>✓ If squeaking occurs lubricate bushings with oil or WD-40®.</li> </ul>	<p><b>SWINGS AND RIDES:</b></p> <ul style="list-style-type: none"> <li>✓ Check swing seats, all ropes, chains and attachments for fraying, wear, excessive corrosion or damage. Replace if structurally damaged or deteriorated.</li> </ul>
--	---

## Check at the end of the play season:

<p><b>SWINGS AND RIDES:</b></p> <ul style="list-style-type: none"> <li>✓ To prolong their life, remove swings and store inside when outside temperature is below 32°F/0°C. Below freezing, plastic parts may become more brittle.</li> </ul>	<p><b>SHOCK ABSORBING SURFACING:</b></p> <ul style="list-style-type: none"> <li>✓ Rake and check depth of loose fill protective surfacing materials to prevent compaction and maintain appropriate depth. Replace as necessary. (See Protective Surfacing, page 4)</li> </ul>
--	---

**If you dispose of your play set:** Please disassemble and dispose of your unit so that it does not create any unreasonable hazards at the time it is discarded. Be sure to follow your local waste ordinances.

## About Our Wood

KidKraft Premium Play Systems uses only premium playset lumber, ensuring the safest product for your children's use. Although we take great care in selecting the best quality lumber available, wood is still a product of nature and susceptible to weathering which can change the appearance of your set.

### **What causes weathering? Does it affect the strength of my Play System?**

One of the main reasons for weathering is the effects of water (moisture); the moisture content of the wood at the surface is different than the interior of the wood. As the climate changes, moisture moves in or out of the wood, causing tension which can result in checking and or warping. You can expect the following due to weathering. These changes will not affect the strength of the product:

1. **Checking** is surface cracks in the wood along the grain. A post (4" x 4") will experience more checking than a board (1" x 4") because the surface and interior moisture content will vary more widely than in thinner wood.
2. **Warping** results from any distortion (twisting, cupping) from the original plane of the board and often happens from rapid wetting and drying of the wood.
3. **Fading** happens as a natural change in the wood color as it is exposed to sun-light and will turn a grey over time.

### **How can I reduce the amount of weathering to my Play System?**

At the factory we have coated the wood with a water repellent or stain. This coating decreases the amount of water absorption during rain or snow thus decreasing the tension in the wood. Sunlight will break down the coating, so we recommend applying a water repellent or stain on a yearly basis (see your local stain and paint supplier for a recommended product).

Most weathering is just the normal result of nature and will not affect safe play and enjoyment for your child. However if you are concerned that a part has experienced a severe weathering problem please call our consumer relations department for further assistance.

**Complete and mail registration card to receive important product notifications and assure prompt warranty service.**

# KidKraft Limited Warranty

## MISSING OR DAMAGED PARTS:

KidKraft will replace any parts within 90 days from date of purchase found to be missing from or damaged in the original packaging. See Fig.1

Fig. 1	<u>Product Age (All Parts)</u> 0-90 Days from date of purchase	<u>Consumer Pays</u> \$0 for Part + Free Shipping
--------	---	--

## DEFECTS IN MATERIAL AND WORKMANSHIP:

KidKraft warrants that this product is free from defects in materials and workmanship for a period of one (1) year from the original date of purchase (dated sales receipt and/or product registration is required). This one (1) year warranty covers all parts including wood, hardware, and all accessories (Such as swings, rides, and slides). See Fig. 2

Fig. 2	<u>Product Age (All Parts)</u> 91 Days to 1 Year	<u>Consumer Pays</u> \$0 for Part + Free Shipping
--------	---	--

## WOOD ROT, DECAY, AND INSECT DAMAGE:

All wood carries a five (5) year warranty against rot, decay, and insect damage (dated sales receipt and/or product registration is required). Refer to the schedule below for charges associated with replacement of wood parts under this **Limited Warranty**. See Fig. 3

Fig. 3	<u>Product Age (Wood Parts)</u> 0 Days to 1 Year After 1 Year to 5 Year Over 5 Years	<u>Consumer Pays</u> \$0 for Part + Free Shipping \$0 for Part + Shipping & Handling 100% for Part (if available) + Shipping & Handling
--------	---	--

This warranty applies to the original owner and registrant and is non-transferable. Regular maintenance is required to ensure the integrity of this product. Failure by the owner to maintain the product according to the maintenance requirements may void this warranty.

This Limited Warranty does NOT cover:

- Any inspection cost
- Labor and/or costs for replacement of any defective item(s), including but not limited to, professional installer costs
- Incidental or consequential damages, including but not limited to, as a result of set relocation, move and/or reinstall
- Cosmetic defects which do not affect performance or integrity of a part or the entire product
- Vandalism, improper use or installation, or acts of nature, including but not limited to, high winds, fire, and flood
- Minor twisting, warping, checking, or any natural occurring properties of wood that do not affect performance or integrity.
- Any KidKraft product purchased, including but not limited to, a non-approved retailer, auction houses, second-hand, and as-is clearance items.

KidKraft products have been designed for safety and quality. Modifications made to the original product may damage the structural integrity of the unit leading to failure and possible injury. KidKraft cannot assume any responsibility for the modified products. Furthermore, modifications void all warranties.

This product is warranted for **RESIDENTIAL USE ONLY**. Under no circumstance should a KidKraft product be used in public settings such as schools, churches, playgrounds, parks, home and professional day cares and the like. Such use may lead to product failure and potential injury. Public use will void this warranty. KidKraft disclaims all other representations and warranties of any kind, express or implied.

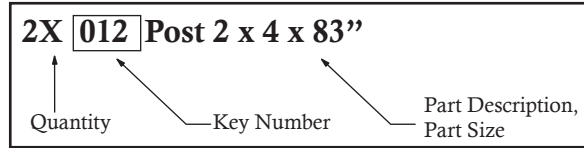
# Keys to Assembly Success

## Tools Required

<ul style="list-style-type: none"> <li>• Tape Measure</li> <li>• Carpenters Level</li> <li>• Carpenters Square</li> <li>• Claw Hammer</li> <li>• Standard or Cordless Drill</li> <li>• Rubber Mallet</li> </ul>	<ul style="list-style-type: none"> <li>• #1 Phillips, #2 Robertson and Screwdriver</li> <li>• Ratchet with extension (1/2" &amp; 7/16" sockets)</li> </ul>	<ul style="list-style-type: none"> <li>• Open End Wrench (1/2" &amp; 7/16")</li> <li>• Adjustable Wrench</li> <li>• 1/8" &amp; 3/16" Drill Bits</li> </ul>	<ul style="list-style-type: none"> <li>• 3/16" Hex Key</li> <li>• 8' Step Ladder</li> <li>• Safety Glasses</li> <li>• Adult Helpers</li> <li>• Pencil</li> </ul>
---	--	--	--

## Part Identification Key

On each page, you will find the parts and quantities required to complete the assembly step illustrated on that page. Here is a sample.



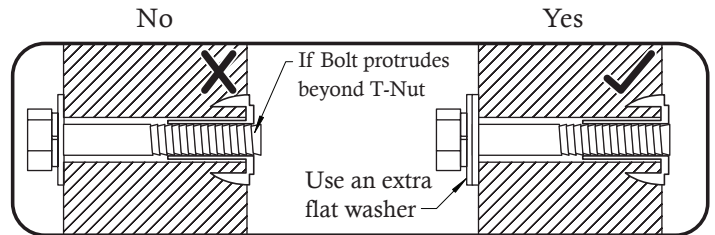
## Symbols

Throughout these instructions symbols are provided as important reminders for proper and safe assembly.

<p>This identifies information that requires special attention. Improper assembly could lead to an unsafe or dangerous condition.</p>	<p>Check that set or assembly is properly level before proceeding.</p> <p>Use Level</p>
<p>Use Help</p> <p>Use Help</p> <p>Where this is shown, 2 or 3 people are required to safely complete the step. To avoid injury or damage to the assembly make sure to get help!</p>	<p>Pre-drill 1/8" &amp; 3/16" Bit</p> <p>Pre-drill a pilot hole before fastening screw or lag to prevent splitting of wood.</p>
<p>Measure Distance</p> <p>Check that assembly is square before tightening bolts.</p> <p>Square Assembly</p> <p>Use a measuring tape to assure proper location.</p>	<p>Tighten Bolts</p> <p>This indicates time to tighten bolts, but not too tight! Do not crush the wood. This may create splinters and cause structural damage.</p>

## CAUTION – Protrusion Hazard

Once the assembly is tightened, watch for exposed threads. If a thread protrudes from the T-Nut, remove the bolt and add washers to eliminate this condition. Extra washers have been provided for this purpose.

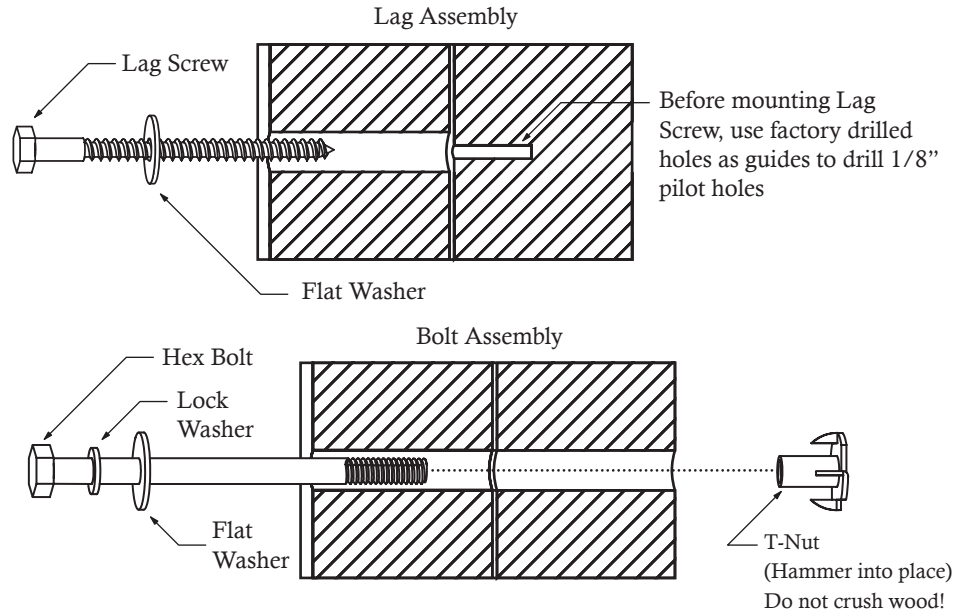


## Proper Hardware Assembly

Lag screws require drilling pilot holes to avoid splitting wood. Only a flat washer is required. For ease of installation liquid soap can be used on all lag-type screws.

For bolts, tap T-Nut into hole with hammer. Insert the hex bolt through lock washer first then flat washer then hole. Because the assemblies need to be squared do not completely tighten until instructed. Pay close attention to diameter of the bolts. 5/16" is slightly larger than 1/4".

Note: Wafer head bolts with blue lock tight or a bolt with a Ny-Lok nut do NOT require a lock washer.





# Part Identification (Reduced Part Size)

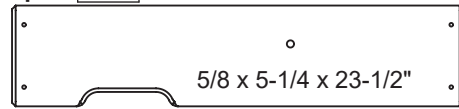
1pc. - **6036** - 63.5 x 82.6 x 1700.2mm - Tire Joist - 3636036



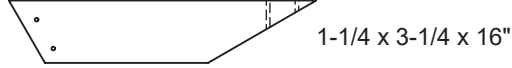
2pc. - **6040** - 31.8 x 82.6 x 367mm - Tunnel End - 3636040



5pc. - **6009** - 15.9 x 133.4 x 596.9mm Rock Board B - 3636009



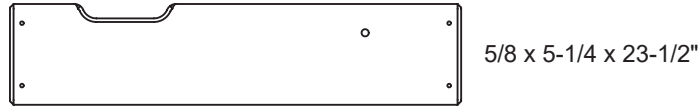
2pc. - **6001** - 31.8 x 82.6 x 406.4mm - Gusset - 3636001



2pc. - **6006** - 31.8 x 82.6 x 396.9mm - Back Gusset - 3636006



4pc. - **6010** - 15.9 x 133.4 x 596.9mm - Rock Board A - 3636010



7pc. - **6013** - 15.9 x 108 x 533.4mm - Floor Board - 3636013



1pc. - **6019** - 15.9 x 133.4 x 596.9mm - Rock Bottom - 3636019



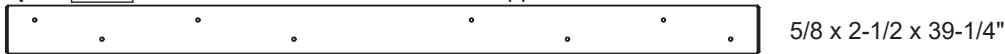
2pc. - **6024** - 15.9 x 82.6 x 901.7mm - Tarp End - 3636024



4pc. - **6031** - 15.9 x 72.6 x 996.9mm - Window Brace - 3636031



2pc. - **6033** - 15.9 x 63.5 x 996.9mm - Post Support - 3636033



2pc. - **2613** - 50.8 x 76.2 x 2201.9mm - Heavy SW Post - 3632613



1pc. - **2615** - 101.6 x 101.6 x 1294.3mm - SW Upright - 3632615



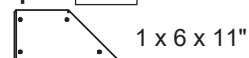
1pc. - **2614** - 101.6 x 152.4 x 2235.2mm - Engineered Beam - 3632614



4pc. - **2790** - 25.4 x 127 x 393.7mm - Transom Board A - 3632790



4pc. - **2791** - 25.4 x 152.4 x 279.4mm - Transom Board B - 3632791



2pc. - **2792** - 31.8 x 76.2 x 1111.3mm - Ground Brace - 3632792

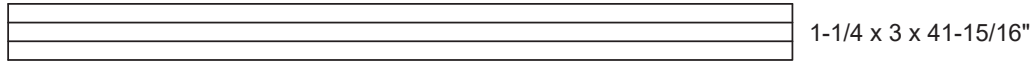


# Part Identification (Reduced Part Size)

1pc. - **2795** - 31.8 x 76.2 x 2152.7mm - Long Joist - 3632795



2pc. - **2601** - 31.8 x 76.2 x 1065.2mm - Lower Jamb - 3632601



1pc. - **2685** - 25.4 x 101.6 x 1031.9mm - Counter Top - 3632685



2pc. - **2716** - 25.4 x 101.6 x 447.7mm - Counter Mid Top - 3632716



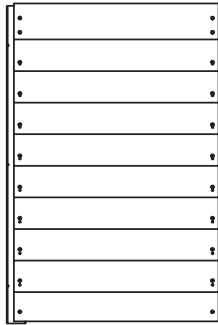
1pc. - **2616** - 31.8 x 101.6 x 1181.1mm - SW Support - 3632616



2pc. - **2671** - 31.8 x 573.1 x 847.7mm

Back Small Roof - 37632671

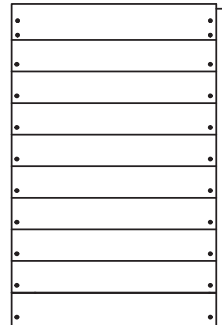
1-1/4 x 22-9/16 x 33-3/8"



2pc. - **2672** - 31.8 x 573.1 x 854.1mm

Front Small Roof - 37632672

1-1/4 x 22-9/16 x 33-5/8"

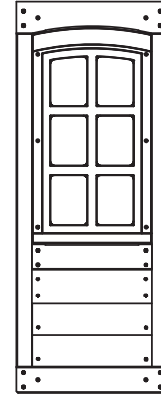


1pc. - **2709**

31.8 x 400 x 1035.1mm

Door Window Panel - 37602709B

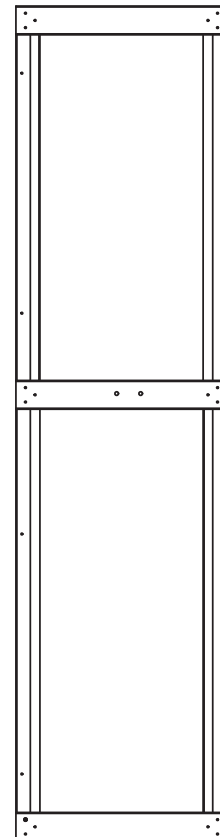
1-1/4 x 15-3/4 x 40-3/4"



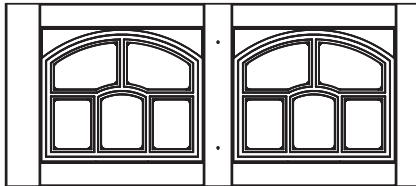
4pc. - **2677** - 31.8 x 558.8 x 2209.8mm

Narrow Panel - 37632677

1-1/4 x 22 x 87"

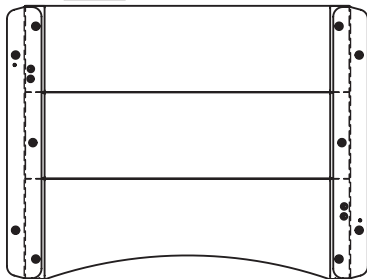


2pc. - **2802** - 31.8 x 482.6 x 1092.2mm - Transom Window - 37632802



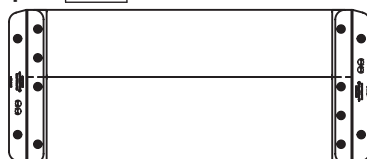
1-1/4 x 19 x 43"

1pc. - **6038** - 32.3 x 362 x 477.4mm - Upper Tunnel Insert - 37636038



1-1/4 x 14-1/4 x 18-3/4"

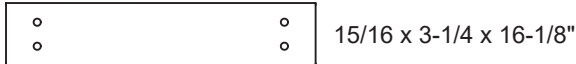
1pc. - **6039** - 32.3 x 203.2 x 477.5mm - Lower Tunnel Insert - 37636039



1-1/4 x 8 x 18-3/4"

# Part Identification (Reduced Part Size)

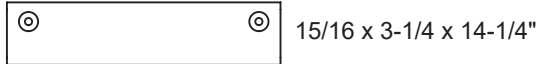
1pc. - **6004** - 23.8 x 82.6 x 409.6mm - Box Bottom - 3636004



2pc. - **6008** - 38.1 x 38.1 x 336.6mm - Tarp Uprght - 3636008



1pc. - **8832** - 23.8 x 82.6 x 362mm - Box End - 3638832



2pc. - **6011** - 23.8 x 82.6 x 768.4mm - Box Side - 3636011



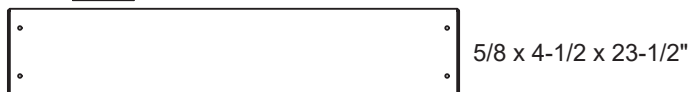
1pc. - **6042** - 15.9 x 98 x 533.4mm - Narrow Floor Board - 3636042



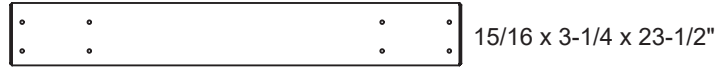
2pc. - **6015** - 23.8 x 82.6 x 444.5mm - Box Leg - 3636015



1pc. - **6021** - 15.9 x 114.3 x 596.9mm - Back Ground - 3636021



1pc. - **6027** - 23.8 x 82.6 x 596.9mm - Sand Water Support - 3636027



1pc. - **6028** - 23.8 x 82.6 x 644.5mm - Top Back - 3636028



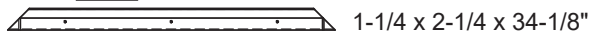
1pc. - **6029** - 23.8 x 82.6 x 784.2mm - Side Top - 3636029



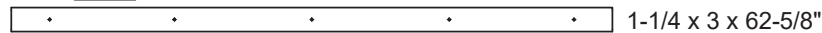
1pc. - **6037** - 29.8 x 120.7 x 428.6mm - Tunnel Top - 3636037



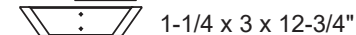
4pc. - **2680** - 31.8 x 57.2 x 866.4mm - Roof Support - 3632680



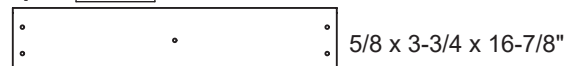
2pc. - **2683** - 31.8 x 76.2 x 1590.7mm - Wall Tie - 3632683



1pc. - **2688** - 31.8 x 76.2 x 323.9mm - Dormer Cleat - 3632688



1pc. - **10078** - 15.9 x 85.7 x 428.6mm - Floor Board - 36310078



# Part Identification (Reduced Part Size)

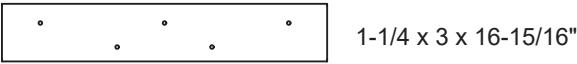
2pc. - **6035** - 31.8 x 82.6 x 1770.1mm - Tunnel Side Joist - 3636035



2pc. - **6012** - 31.8 x 82.6 x 933.6mm - Short Post - 3636012



1pc. - **6014** - 31.8 x 76.2 x 430.2mm - Tunnel Spacer - 3636014



2pc. - **6017** - 31.8 x 82.6 x 875.3mm - Floor Support - 3636017



1pc. - **6030** - 23.8 x 82.6 x 784.2mm - Tunnel Side Top - 3636030



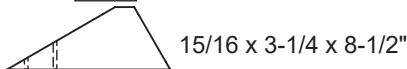
1pc. - **6032** - 31.8 x 108 x 874mm - TNR Wall - 3636032



1pc. - **6034** - 23.8 x 139.7 x 596.9mm - Floor Back - 3636034



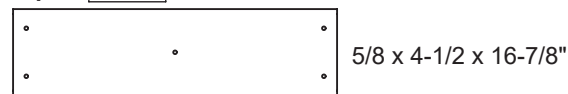
2pc. - **8834** - 23.8 x 82.6 x 216mm - Box Gusset FSC - 3638834



1pc. - **0369** - 34.9 x 63.5 x 939.8mm Lower Diagonal - 3640369



14pc. - **10077** - 15.9 x 114.3 x 428.6mm - Floor Board - 36310077



2pc. - **0601** - 15.9 x 76.2 x 500mm - Side Trim - 3620601



2pc. - **6002** - 31.8 x 82.6 x 1968.5mm Long Post - 3636002



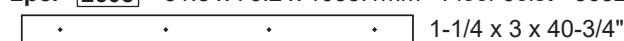
1pc. - **6003** - 23.8 x 50.8 x 862.2mm Floor Joist - 3636003



1pc. - **6005** - 31.8 x 82.6 x 222.3mm TNR Slide Block - 3636005

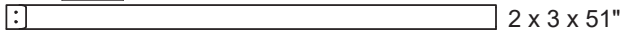


2pc. - **2608** - 31.8 x 76.2 x 1035.1mm - Floor Joist - 3632608

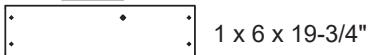


# Part Identification (Reduced Part Size)

**2pc. - [0349]** - 50.8 x 76.2 x 1295.4mm - Rock Rail - 3640349



**2pc. - [2603]** - 25.4 x 152.4 x 501.7mm - Rock Board A - 3632603



**3pc. - [2604]** - 25.4 x 152.4 x 501.7mm - Rock Board B - 3632604



**2pc. - [2605]** - 25.4 x 152.4 x 501.7mm - Access Board - 3632605



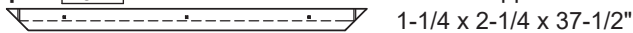
**2pc. - [2606]** - 23.8 x 101.6 x 362mm - SW Ground - 3632606



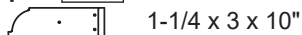
**1pc. - [2612]** - 50.8 x 50.8 x 1006.5mm - Table Support - 3632612



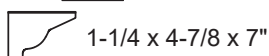
**4pc. - [2617]** - 31.8 x 57.2 x 952.5mm - Roof Support - 3632617



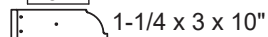
**2pc. - [2646]** - 31.8 x 76.2 x 254mm - Roof End - 3632646



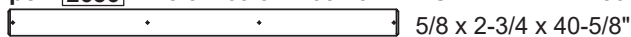
**4pc. - [2684]** - 31.8 x 123.8 x 177.8mm - Mid Roof End - 3632684



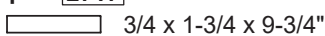
**2pc. - [2647]** - 31.8 x 76.2 x 254mm - Roof End Left - 3632647



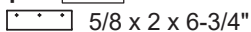
**1pc. - [2686]** - 15.9 x 69.9 x 1031.9mm - Counter Front - 3632686



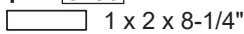
**2pc. - [2717]** - 19.1 x 44.5 x 247.7mm - Clock Block - 3632717



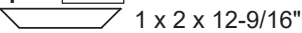
**2pc. - [5536]** - 15.9 x 50.8 x 171.5mm - Counter Side - 38045536



**4pc. - [5736]** - 25.4 x 50.8 x 209.6mm - Counter Joist - 38045736



**2pc. - [6136]** - 25.4 x 50.8 x 319.1mm - Counter Brace - 38046136



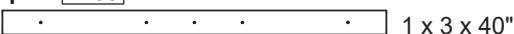
**1pc. - [2715]** - 25.4 x 76.2 x 254.0mm - Door Stop - 3632715



**4pc. - [2788]** - 31.8 x 63.5 x 943.0mm - Mid Roof Support - 3632788



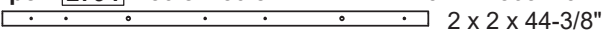
**4pc. - [2789]** - 25.4 x 76.2 x 1016mm - Short Wall Tie - 3632789



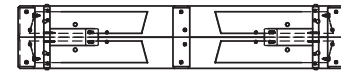
**4pc. - [2793]** - 31.8 x 76.2 x 476.3mm - Long Roof End - 3632793



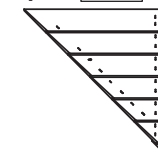
**2pc. - [2794]** - 50.8 x 50.8 x 1127.1mm - Joist - 3632794



**1pc. - [2658]** - 61.1 x 171.5 x 863.6mm - Folding Bench - 37632658

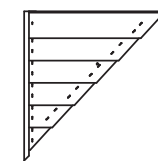


**1pc. - [2689]** - 31.8 x 370.8 x 558.8mm



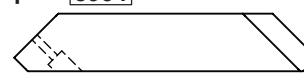
1-1/4 x 14-5/8 x 22"

**1pc. - [2699]** - 31.8 x 370.8 x 558.8mm

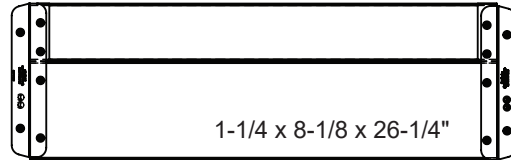


1-1/4 x 14-5/8 x 22"

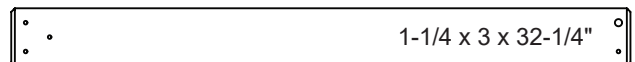
**1pc. - [8934]** - 31.8 x 76.2 x 400mm - SL Gusset - 3638934



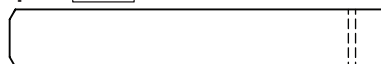
**1pc. - [8935]** - 32.2 x 206.4 x 668.3mm - Lower SL Insert - 37638935



**1pc. - [8963]** - 31.8 x 3 x 819.2mm - TNR Ground Brace - 3638963



**1pc. - [8965]** - 31.8 x 76.2 x 514.4mm - TNR Upright - 3638965



# Part Identification (Reduced Part Size)

1pc. - **0600** - 15.9 x 101.6 x 596.9mm Bottom Trim - 3620600



2pc. - **0602** - 15.9 x 76.2 x 420mm - Short Trim - 3620602



1pc. - **0603** - 15.9 X 82.6 X 644.5mm - Top Trim - 3620603



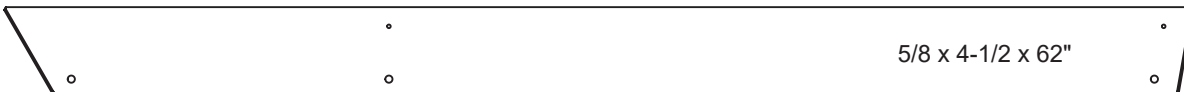
2pc. - **6000** - 31.8 x 82.6 x 1495.4mm - Upper Post - 3636000



2pc. - **6007** - 31.8 x 76.2 x 1095.4mm - Wall Support - 3636007



1pc. - **6018** - 15.9 x 114.3 x 1576.1mm - Long Ground - 3636018



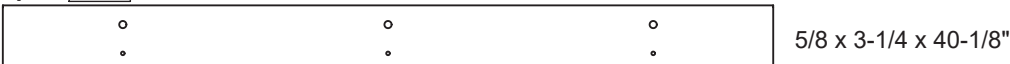
1pc. - **6020** - 15.9 x 114.3 x 1122mm - Short Ground - 3636020



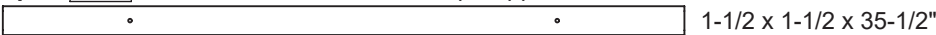
1pc. - **6022** - 31.8 x 63.5 x 616mm - SL Brace - 3636022



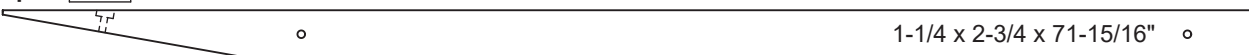
2pc. - **6023** - 15.9 x 82.6 x 1019.2mm - Roof Side - 3636023



1pc. - **6025** - 38.1 x 38.1 x 901.7mm - Tarp Support - 3636025



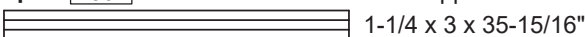
2pc. - **6026** - 31.8 x 69.9 x 1827mm - Rock Rail - 3636026



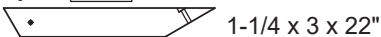
5pc. - **10075** - 25.4 x 127 x 1031.9mm - Floor Board - 36310075



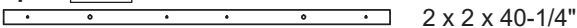
1pc. - **2602** - 31.8 x 76.2 x 404.8mm - Upper Jamb - 3632602



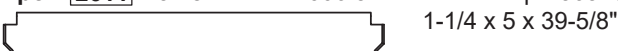
2pc. - **2607** - 31.8 x 76.2 x 558.8mm - Diagonal - 3632607



2pc. - **2610** - 50.8 x 50.8 x 1022.4mm - Side Joist - 3632610



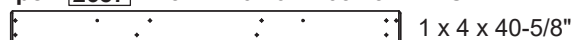
1pc. - **2611** - 31.8 x 127 x 1006.5mm - Table Top - 3632611



1pc. - **10076** - 25.4 x 101.6 x 1031.9mm - Floor Board - 36310076

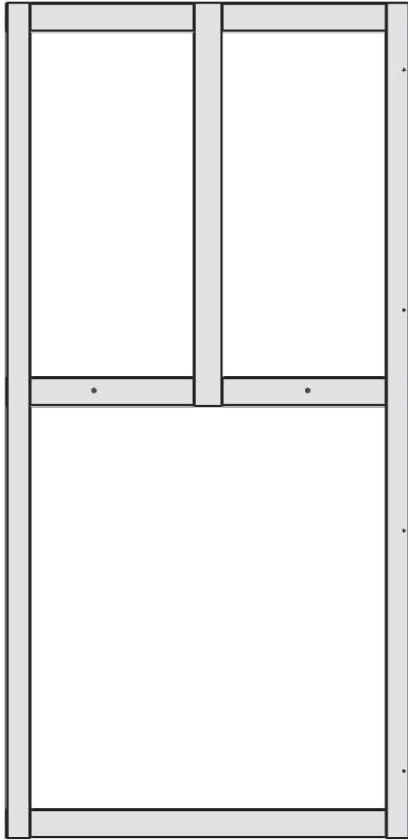


1pc. - **2687** - 25.4 x 101.6 x 1031.9mm - Counter Back - 3632687

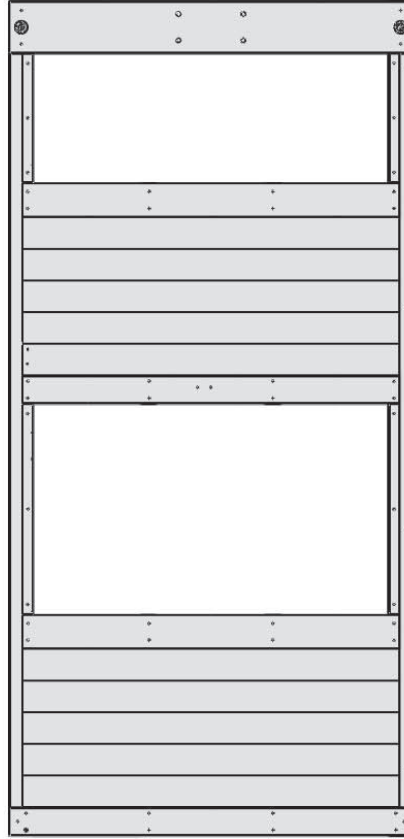


# Part Identification (Reduced Part Size)

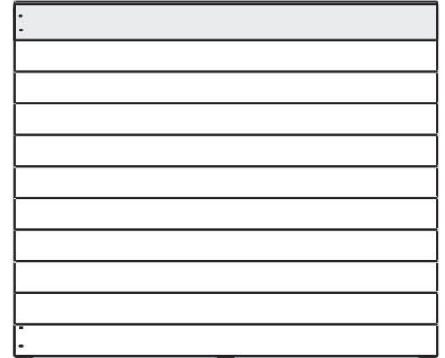
**2pc. - [2618]** - 31.8 x 1066.8 x 2209.8mm  
 Front Back Panel - 37632618  
 1-1/4 x 42 x 87"



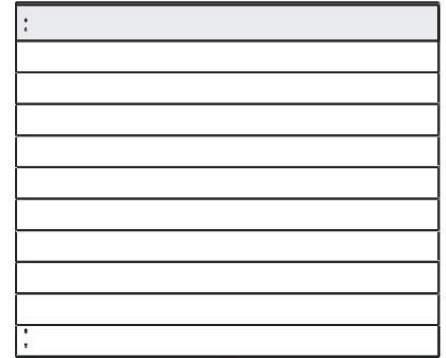
**1pc. - [2627]** - 31.8 x 1066.8 x 2209.8mm  
 SW Wall Panel - 37632627  
 1-1/4 x 42 x 87"



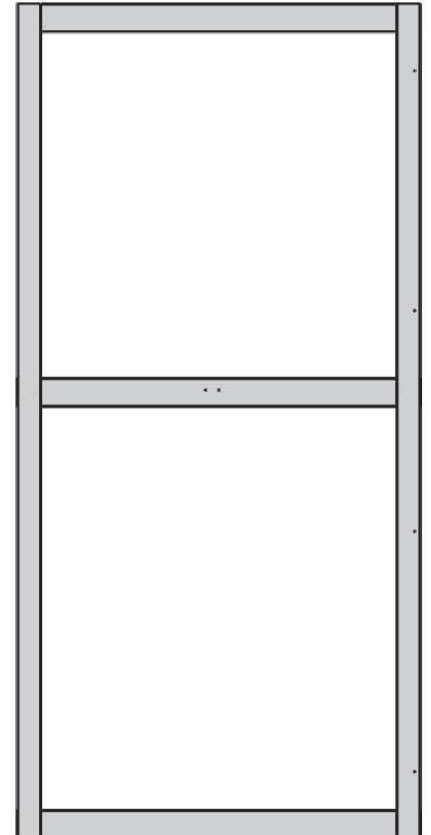
**1pc. - [2639]** - 31.8 x 933.5 x 1117.6mm  
 Back Roof Panel - 37632639  
 1-1/4 x 36-3/4 x 44"



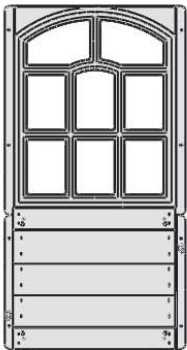
**1pc. - [2644]** - 31.8 x 939.8 x 1117.6mm  
 Front Roof Panel - 37632644  
 1-1/4 x 37 x 44"



**1pc. - [2622]** - 31.8 x 1066.8 x 2209.8mm  
 End Panel Assembly - 37632622  
 1-1/4 x 42 x 87"



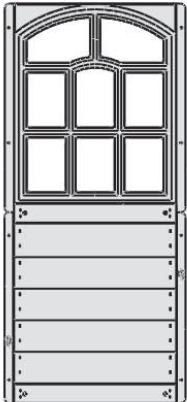
**5pc. - [2655]**  
 32.3 x 477.5 x 910.8mm  
 Upper Window Insert - 37632655  
 1-1/4 x 18-7/8 x 35-15/16"



**1pc.**  
**MOD 3 Pane Transom (2Pk)**  
 3320138

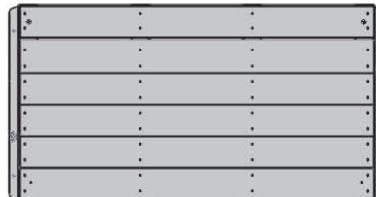


**4pc. - [649A]**  
 31.8 x 479.4 x 404.8mm  
 Short Half Wall - 37632649A  
 1-1/4 x 18-7/8 x 20-15/16"



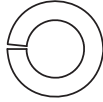
**3pc. - [2649]**  
 32.3 x 477.5 x 1064.3mm  
 Lower Window Insert  
 37632649  
 1-1/4 x 18-7/8 x 41-15/16"

**1pc. - [2665]**  
 35.6 x 514.4 x 984.3mm - Half Wall Insert - 37632665  
 1-3/8 x 20-1/4 x 38-3/4"

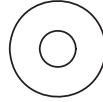


# Hardware Identification (Actual Size)

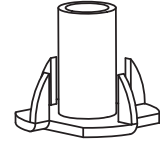
9pc. **(LW2)** - 5/16" Lock Washer - (51303300)



18pc. **(FW0)** - 3/16" Flat Washer - (51103100)



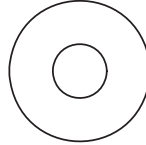
54pc. **(TN1)** - 1/4" T - Nut (54503200)



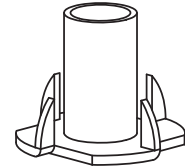
68pc. **(LW1)** - 1/4" Lock Washer - (51303200)



79pc. **(FW1)** - 1/4" Flat Washer - (51103200)



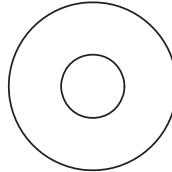
12pc. **(TN2)** - 5/16" T - Nut - (54503300)



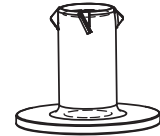
94pc. **(LN1)** - 1/4 Lock Nut - (9283200)



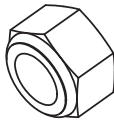
70pc. **(FW2)** - 5/16" Flat Washer - (51103300)



14pc. **(BN1)** - 1/4" Barrel Nut - (54803200)



29pc. **(LN2)** - 5/16" Lock Nut - (54303300)



24pc. **(LN4)** - #12 Lock Nut - (54303600)



20pc. **(FW3)** - #8 Flat Washer - (51003500)



154pc. **(S20)** - Wood Screw #8 x 1-3/8" - (52043516)



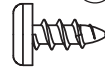
20pc. **(TS)** - Trim Screw #6 x 30mm - (52953911)



261pc. **(S2)** - Wood Screw #8 x 1-1/2" - (52043512)



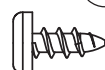
36pc. **(S5)** - Pan Screw #8 x 1/2" - (52433502)



36pc. **(S15)** - Wood Screw #8 x 1-3/4" - (52043513)



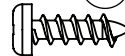
16pc. **(S13)** - Pan Screw #6 x 5/8" - (52413908)



139pc. **(S11)** - Wood Screw #8 x 2" - (52043520)



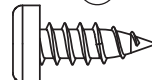
42pc. **(S37)** - Pan Screw #7 x 5/8" - (52433009)



57pc. **(S3)** - Wood Screw #8 x 2-1/2" - (52043522)



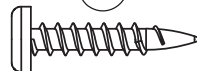
38pc. **(S8)** - Pan Screw #12 x 3/4" - (52433603)



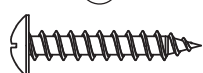
64pc. **(S4)** - Wood Screw #8 x 3" - (52043530)



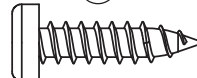
67pc. **(S10)** - Pan Screw #8 x 1" - (52433510)



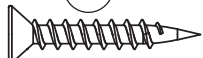
191pc. **(S0)** - Truss Screw #8 x 7/8" - (52933505)



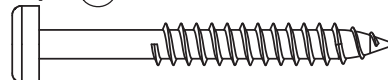
21pc. **(S6)** - Pan Screw #12 x 1" - (52433610)



8pc. **(S18)** - Wood Screw #6 x 1" - (52013910)



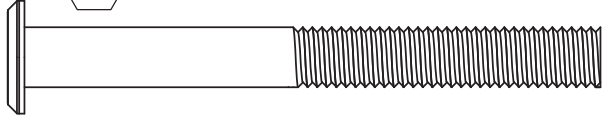
38pc. **(S7)** - Pan Screw #12 x 2" - (52433620)



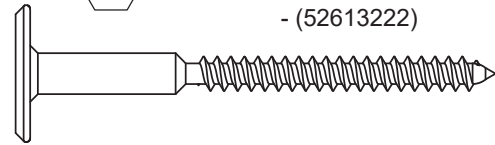


# Hardware Identification (Actual Size)

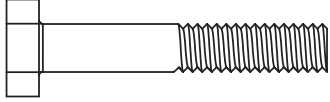
3pc. **WB7** - Wafer Bolt 5/16 x 3" - (53613330)



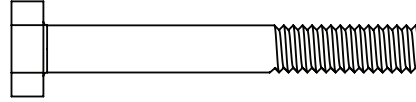
17pc. **WL5** - Wafer Lag 1/4 x 2-1/2" - (52613222)



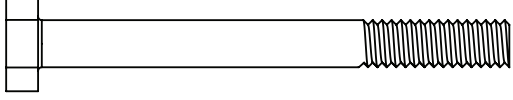
6pc. **H1** - Hex Bolt 1/4 x 1-1/2" - (53703212)



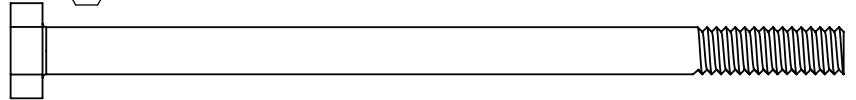
21pc. **H2** - Hex Bolt 1/4 x 2" - (53703220)



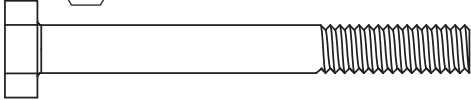
10pc. **H3** - Hex Bolt 1/4 x 2-1/2" - (53703222)



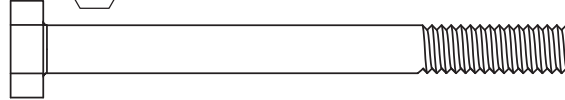
5pc. **H8** - Hex Bolt 1/4 x 4-1/4" - (53703241)



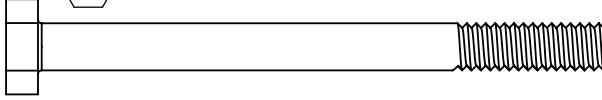
2pc. **H10** - Hex Bolt 1/4 x 2-1/4" - (53703221)



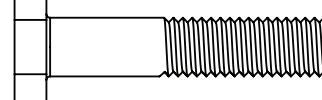
8pc. **H11** - Hex Bolt 1/4 x 2-3/4" - (53703223)



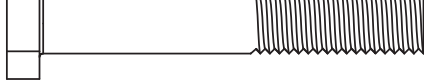
4pc. **H12** - Hex Bolt 1/4 x 3" - (53703230)



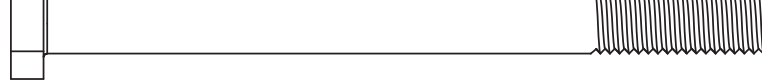
4pc. **G1** - Hex Bolt 5/16 x 1-1/2" - (53703312)



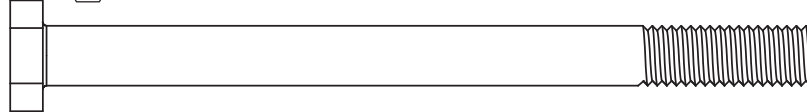
4pc. **G8** - Hex Bolt 5/16 x 2" - (53703320)



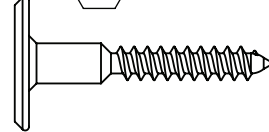
7pc. **G21** - Hex Bolt 5/16 x 3-3/4" - (53703333)



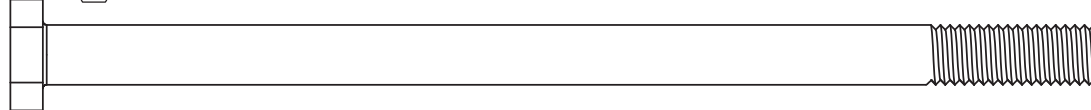
3pc. **G4** - Hex Bolt 5/16 x 4" - (53703340)



8pc. **WL3** - Wafer Lag 1/4 x 1-3/8" - (52613216)



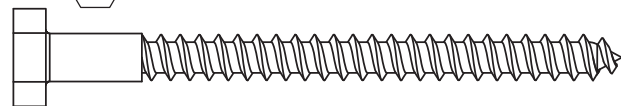
14pc. **G7** - Hex Bolt 5/16 x 5-1/2" - (53703352)



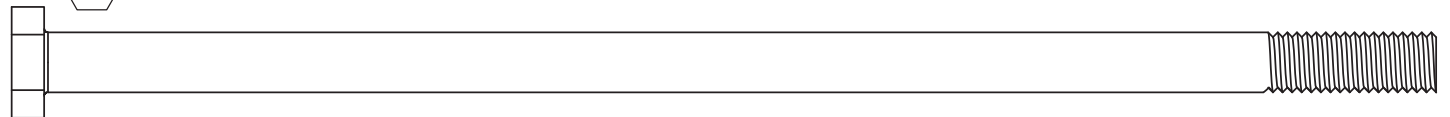
5pc. **LS2** - Lag Screw 1/4 x 2-1/2" - (52213222)



5pc. **LS3** - Lag Screw 1/4 x 3" - (52213230)

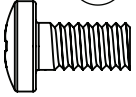


2pc. **G25** - Hex Bolt 5/16 x 7-1/4" - (53703371)

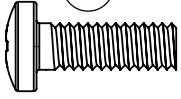


# Hardware Identification (Actual Size)

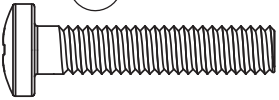
24pc. **MB1** - Pan Bolt #12 x 1/2" - (53433602)



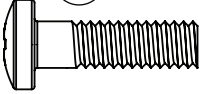
94pc. **PB1** - Pan Bolt 1/4 x 3/4" - (9274203)



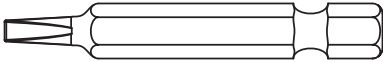
15pc. **PB2** - Pan Bolt 1/4 x 1-1/4" - (53433212)



1pc. **PB6** - Pan Bolt 1/4 x 1" - (9274210)



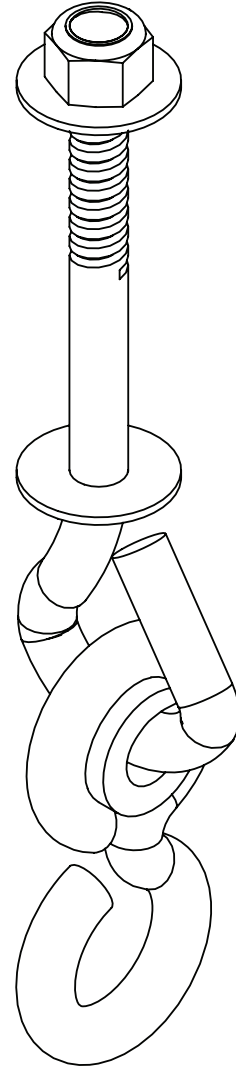
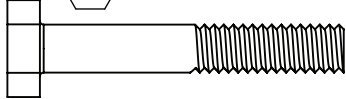
1pc. **D4** - 2 x 2 Robertson Driver Bit - (9200014)



8pc. **FW6**  
#12 Screw Bezel  
(9299500)



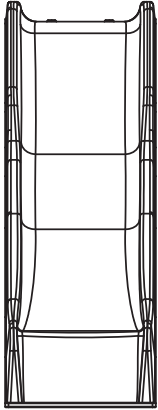
4pc. **G27** - Hex Bolt 5/16 x 1-3/4" - (53709913)



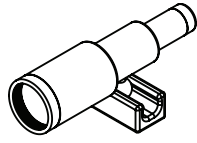
1pc. - 2.75in Swing Bolt Hanger Set (2 Pk)  
(3202023)

# Part Identification (Reduced Part Size)

2x - 48" High Rail Slide  
(7310149-1)



1x - Telescope w/ Mount  
(3320161)



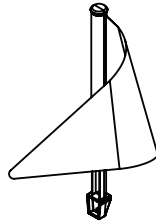
2x - Steel Hand Grip  
(9200311) - Red



1x - Spiral Wave Bracket (2Pk)  
(3201500)



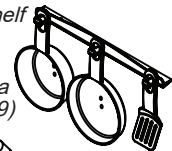
2x - Flag and Pole (2 Pk)  
(3320632)



1x - Rocks (9pk) (3320100)  
(Green/Burgundy)



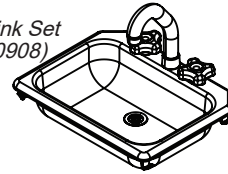
1x - Utensils Shelf  
(9320791)



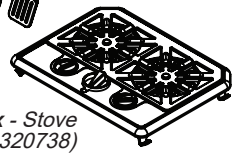
1x - Pot Pan Spatula  
(9320889)



1x - Sink Set  
(3330908)



1x - Stove  
(3320738)



1x - Faucet (9320881)

1x - Sink Knob (9320482)

1x - Sink Knob (9320382)

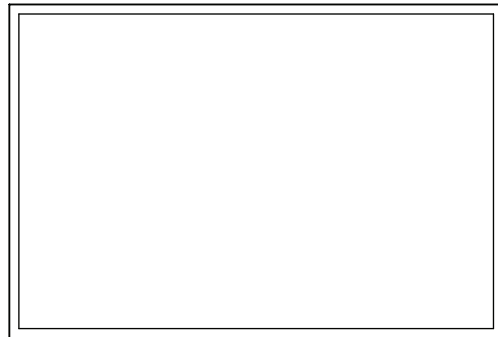
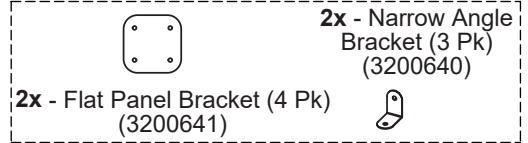
1x - Sink (9330908)

10x - #6 x 10mm Blunt  
Point Pan Screw  
(52402902)

8x - Mount Clips  
(9320088)

1x - Deluxe Kitchen Set - (3320969)

2x - ADD ON C Bracket Set (3204910)

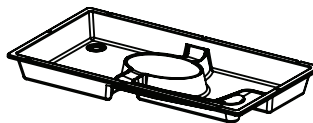


1x - Tower Canopy (3754810)

1x - Seat  
(9320123)

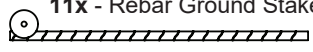


1x - Plug, Shovel  
(3320303)



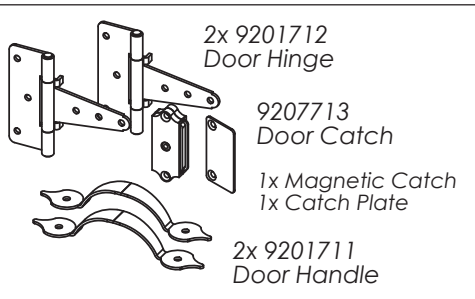
1x - Sand and Water Insert  
(9320105)

11x - Rebar Ground Stake  
(9290318)



5x - Sky Gable  
(3320212)

## 1x - Door Hardware (3201710)



2x 9201712  
Door Hinge

9207713  
Door Catch

1x Magnetic Catch  
1x Catch Plate

2x 9201711  
Door Handle



1x - Corner  
Brace (4 Pk)  
(3201103)

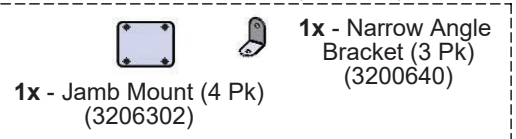


1x - Sky Chalk Wall  
(3320217)



1x - Jamb Mount (2 Pk)  
(3206301)

1x - Bracket Set (3206303)



1x - Jamb Mount (4 Pk)  
(3206302)

1x - Narrow Angle  
Bracket (3 Pk)  
(3200640)

1x - Base Clock  
(9320124)

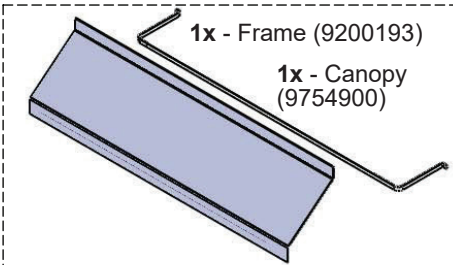


1x - Rocks (5pk)  
(3320386)



1x - Clock Subset  
(3320329)

1x - Cafe Canopy Set (3754900)



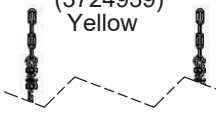
1x - Frame (9200193)

1x - Canopy  
(9754900)



1x - KidKraft ID  
Plaque  
(9320374)

2x - Long Belt Swing  
(3724939)  
Yellow



1x - KidKraft Logo Plaque  
(3320353)

1x - Glider Hanger (2pk)  
(3200105)



1x - L Beam Brkt.  
(3200145) (2pk)



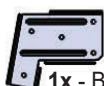
1x - Space Glider Body  
(3320268) Yellow



2x - Space Glider Handle  
(3320177) Green



1x - Beam Brkt.  
Left (9200144)



1x - Beam Brkt.  
Right (9200143)



4x - Swing Hanger  
(9200106)

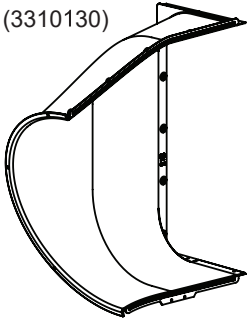


1x - Glider Rope & Chain (4Pk) (3533862)

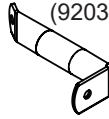


# Part Identification (Reduced Part Size)

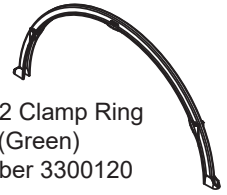
1x - TNR3 Extend Flange Lt (Green)  
(3310130)



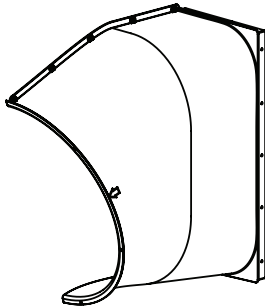
1x - TNR 3 Tube Support  
(9203601)



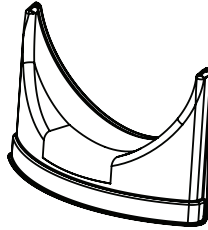
10x - TNR 2 Clamp Ring  
(9300120) (Green)  
10pcs number 3300120



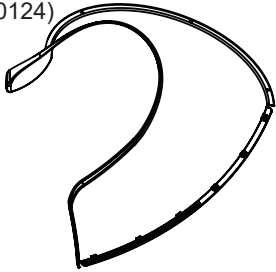
1x - TNR3 Extend Flange Rt  
(3310131) Green



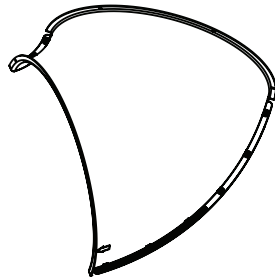
1x - TNR3 Short Exit  
(3310132) Green



1x - TNR 2 Slide Exit Top (Green)  
(3310124)



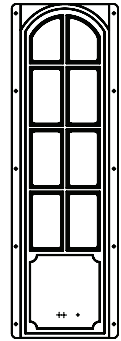
9x - TNR 2 Slide Elbow  
(3310121) Green



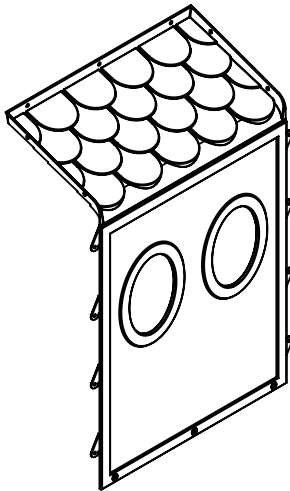
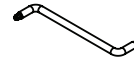
1x - TNR3 Post Mount  
(9203602)



1x - MOD Side Lite  
(9320116)

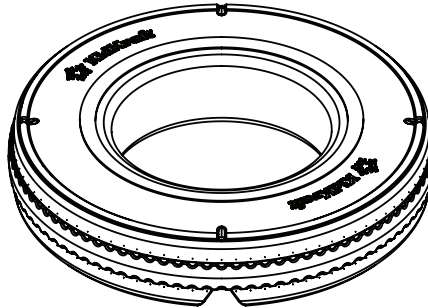


1x - Quadrex Driver  
(9200015)



8x - Mod Tunnel Panel  
(9330101)

1x - Tire (3320702)



2x - Flat Panel Brkt (2 Pk)  
3200636



1x - Swing Brkt Set (4 Pk)  
(3201532)



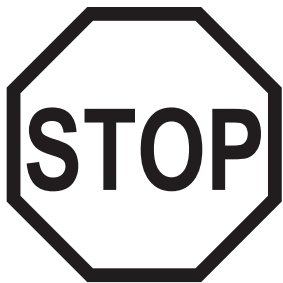
1x - Swing Brkt Set (2 Pk)  
(3201533)



1x - Tire Rope & Chain (4 Pk)  
(3533870)

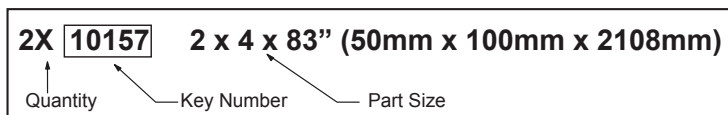


## Step 1: Inventory Parts - Read This Before Starting Assembly



Inventory should be completed before starting installation. KidKraft will not cover costs of any additional installation trip due to missing or damaged pieces.

- A. This is the time for you to inventory all your hardware, wood and accessories, referencing the parts identification sheets. This will assist you with your assembly.
- The wood pieces will have the key number stamped on the ends of the boards. Organize the wood pieces by step, as per the key numbering system below.



- B. Read the assembly manual completely, paying special attention to ANSI warnings; notes; and safety/maintenance information on pages 1 - 9.

**If there are missing or damaged pieces,  
please contact the KidKraft Consumer Engagement team  
before going back to the retailer.**

## Order Replacement Parts 24/7

You can order replacement parts for this product 24 hours a day / 7 days a week:

**Outdoor Swingsets and Playhouse Parts Ordering**

**<https://parts.kidkraft.com/>**

If you have assembly or product questions, please refer to the front cover for direct contact information for our Consumer Engagement team.

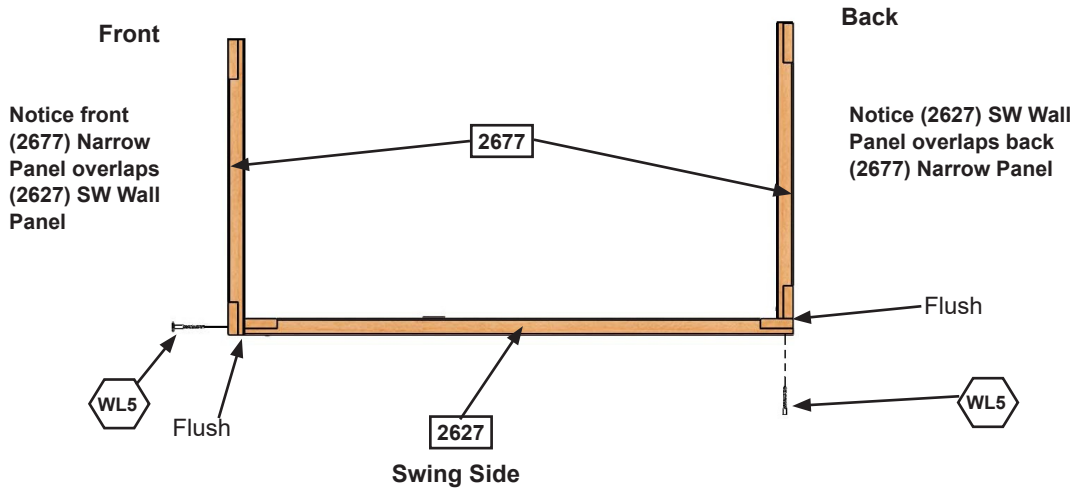
# Step 2: Frame Assembly Part 1



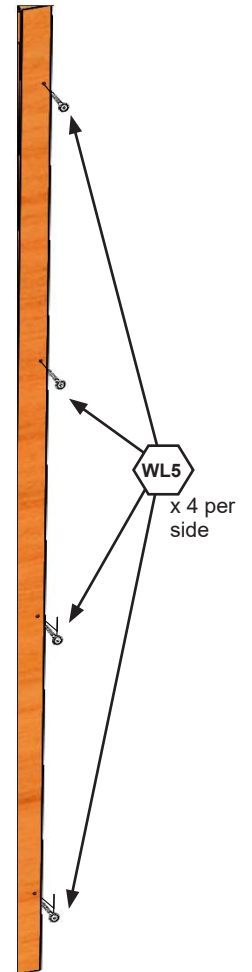
*It is important to assemble the frame on a flat, smooth surface.*

**A:** Place (2627) SW Wall Panel between 2 (2677) Narrow Panels noticing the panel orientations. The tops and bottoms of the panels should be flush. Make sure the panels are square then using the pilot holes as a guide pre-drill with a 3/16" drill bit and fasten the front (2677) Narrow Panel to (2627) SW Wall Panel and (2627) SW Wall Panel to the back (2677) Narrow Panel with 4 (WL5) 1/4 x 2-1/2" Wafer Lags per side. (fig. 2.1, 2.2 and 2.3)

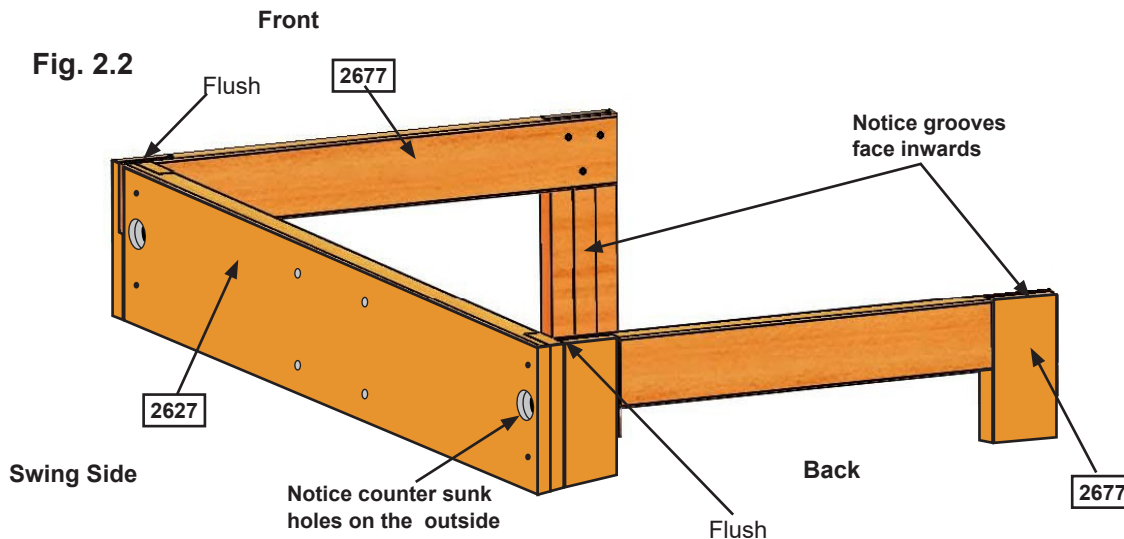
**Fig. 2.1**  
Top View



**Fig. 2.3**



**Fig. 2.2**



**Wood Parts**

- 2 x 2677 Narrow Panel 1-1/4 x 22 x 87"
- 1 x 2627 SW Wall Panel 1-1/4 x 42 x 87"

**Hardware**

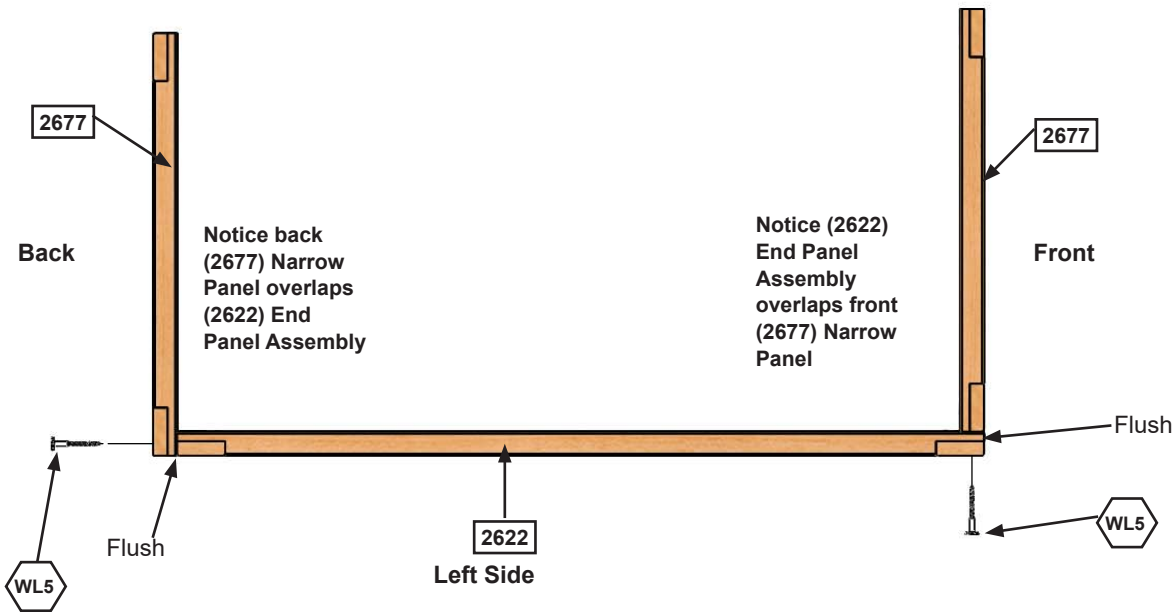
- 8 x WL5 1/4 x 2-1/2" Wafer Lag

# Step 2: Frame Assembly Part 2

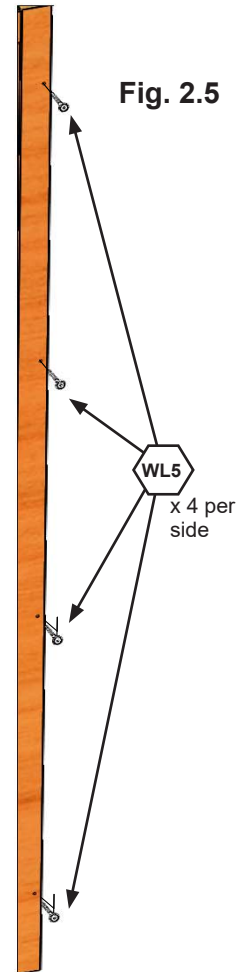


**B:** Place (2622) End Panel Assembly between 2 (2677) Narrow Panels noticing the panel orientations. The tops and bottoms of the panels should be flush. Make sure the panels are square then using the pilot holes as a guide pre-drill with a 3/16" drill bit and fasten the back (2677) Narrow Panel to (2622) End Panel Assembly and (2622) End Panel Assembly to the front (2677) Narrow Panel with 4 (WL5) 1/4 x 2-1/2" Wafer Lags per side. (fig. 2.4, 2.5 and 2.6)

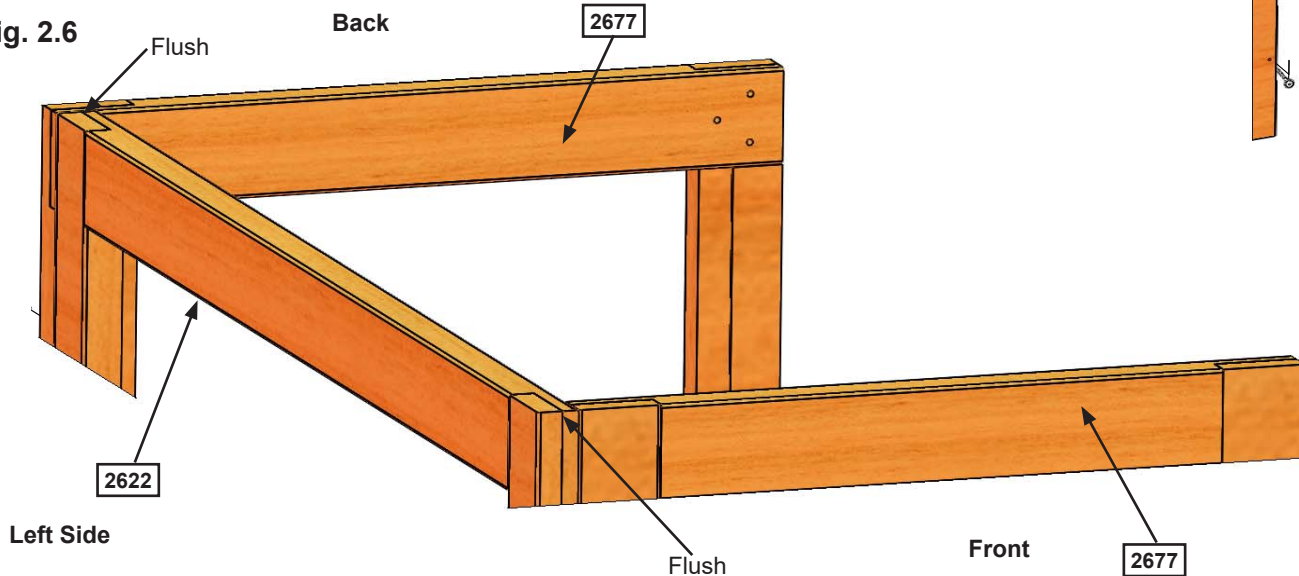
**Fig. 2.4**  
Top View



**Fig. 2.5**



**Fig. 2.6**



**Wood Parts**

- 1 x (2622) End Panel Assembly 1-1/4 x 42 x 87"
- 2 x (2677) Narrow Panel 1-1/4 x 22 x 87"

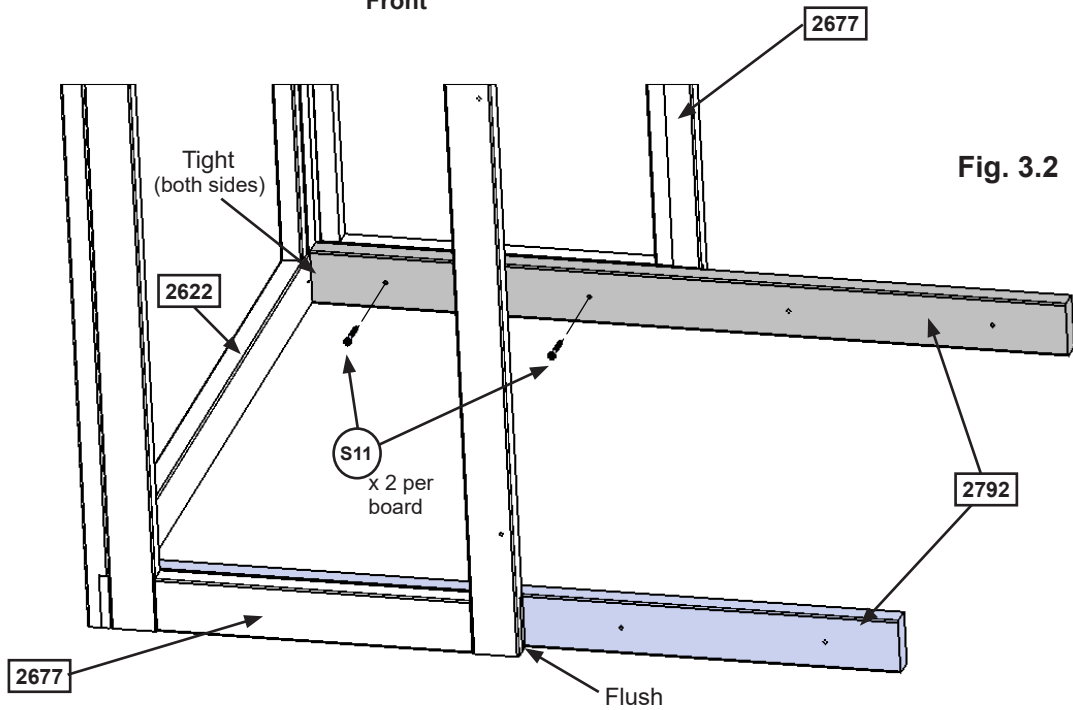
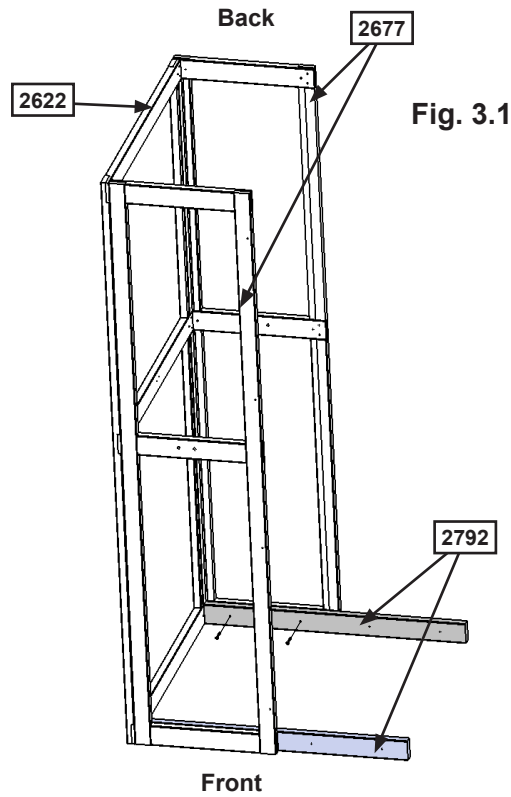
**Hardware**

- 8 x (WL5) 1/4 x 2-1/2" Wafer Lag

# Step 3: Join Frame Assemblies

## Part 1

**A:** Tight to the inside of the (2622) End Panel Assembly and flush to the bottom of the panels attach 1 (2792) Ground Brace to each (2677) Narrow Panel with 2 (S11) #8 x 2" Wood Screws per board. (fig. 3.1 and 3.2)



### Wood Parts

2 x **2792** Ground Brace 1-1/4 x 3 x 43-3/4"

### Hardware

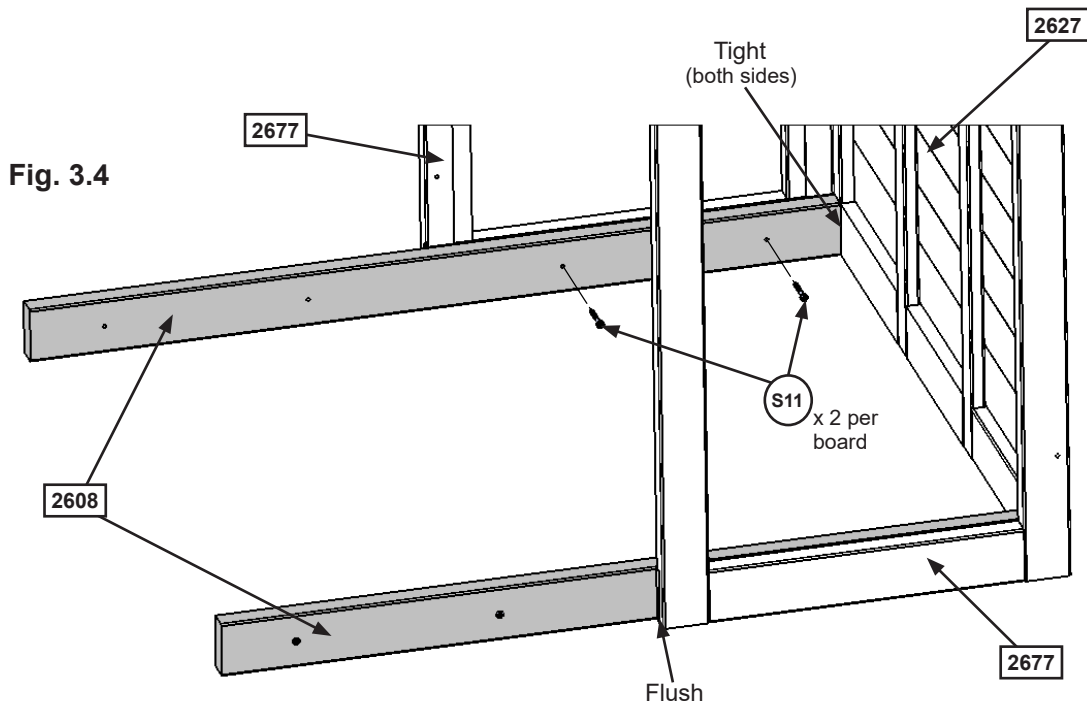
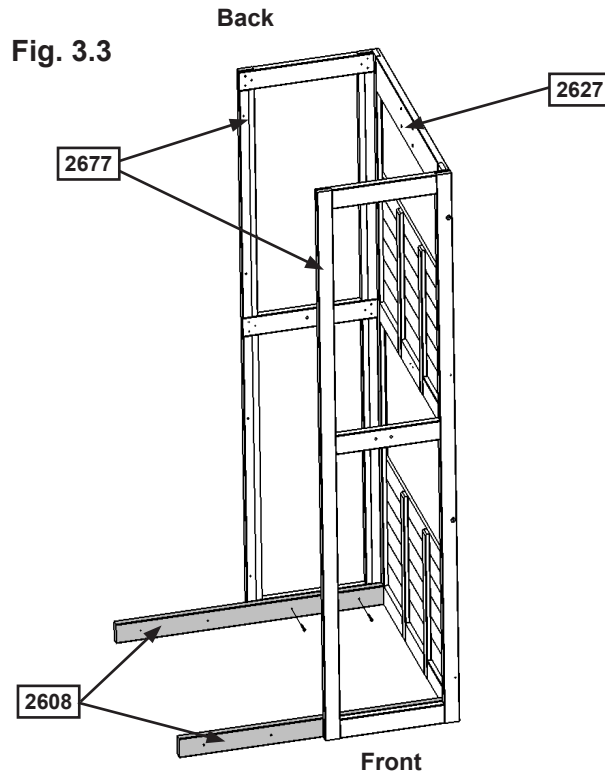
4 x **S11** #8 x 2" Wood Screw



# Step 3: Join Frame Assemblies

## Part 2

**B:** Tight to the inside of the (2627) SW Wall Panel and flush to the bottom of the panels attach 1 (2608) Floor Joist to each (2677) Narrow Panel with 2 (S11) #8 x 2" Wood Screws per board. (fig. 3.3 and 3.4)



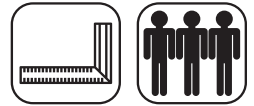
### Wood Parts

2 x 2608 Floor Joist 1-1/4 x 3 x 40-3/4"

### Hardware

4 x S11 #8 x 2" Wood Screw

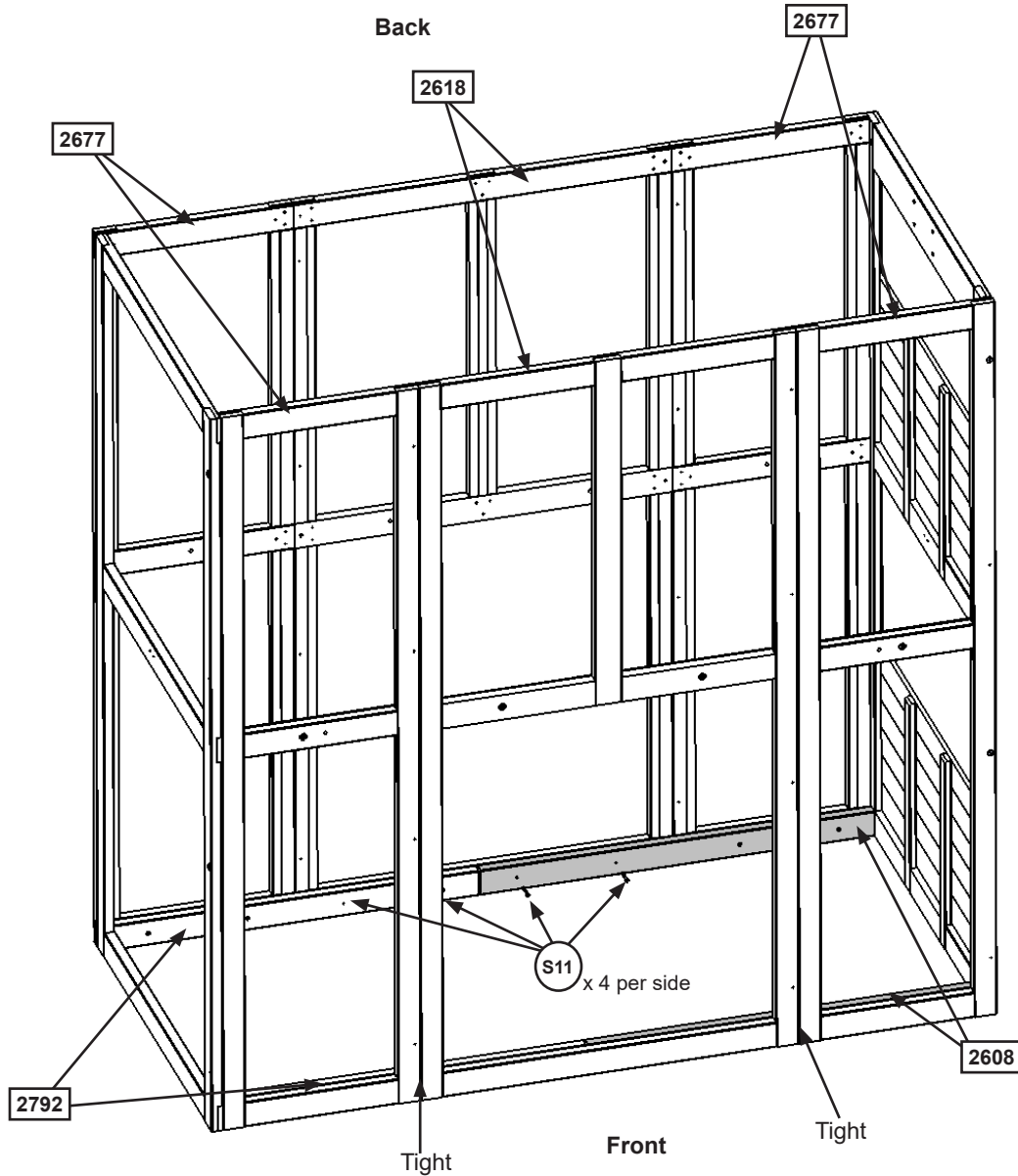
# Step 3: Join Frame Assemblies Part 3



**C:** With at least two helpers lift the two wall assemblies so the (2792) Ground Braces meet the (2608) Floor Joist as shown in fig. 3.5.

**D:** Place 1 (2618) Front Back Panel between the 2 (2677) Narrow Panels on the outside of the (2792) Ground Braces and (2608) Floor Joists on the front and back walls then from the inside of the assembly attach (2792) Ground Braces and (2608) Floor Joists to each (2618) Front Back Panel with 4 (S11) #8 x 2" Wood Screws per panel. (fig. 3.5)

Fig. 3.5



### Wood Parts

2 x 2618 Front Back Panel 1-1/4 x 42 x 87"

### Hardware

8 x S11 #8 x 2" Wood Screw

# Step 3: Join Frame Assemblies Part 4

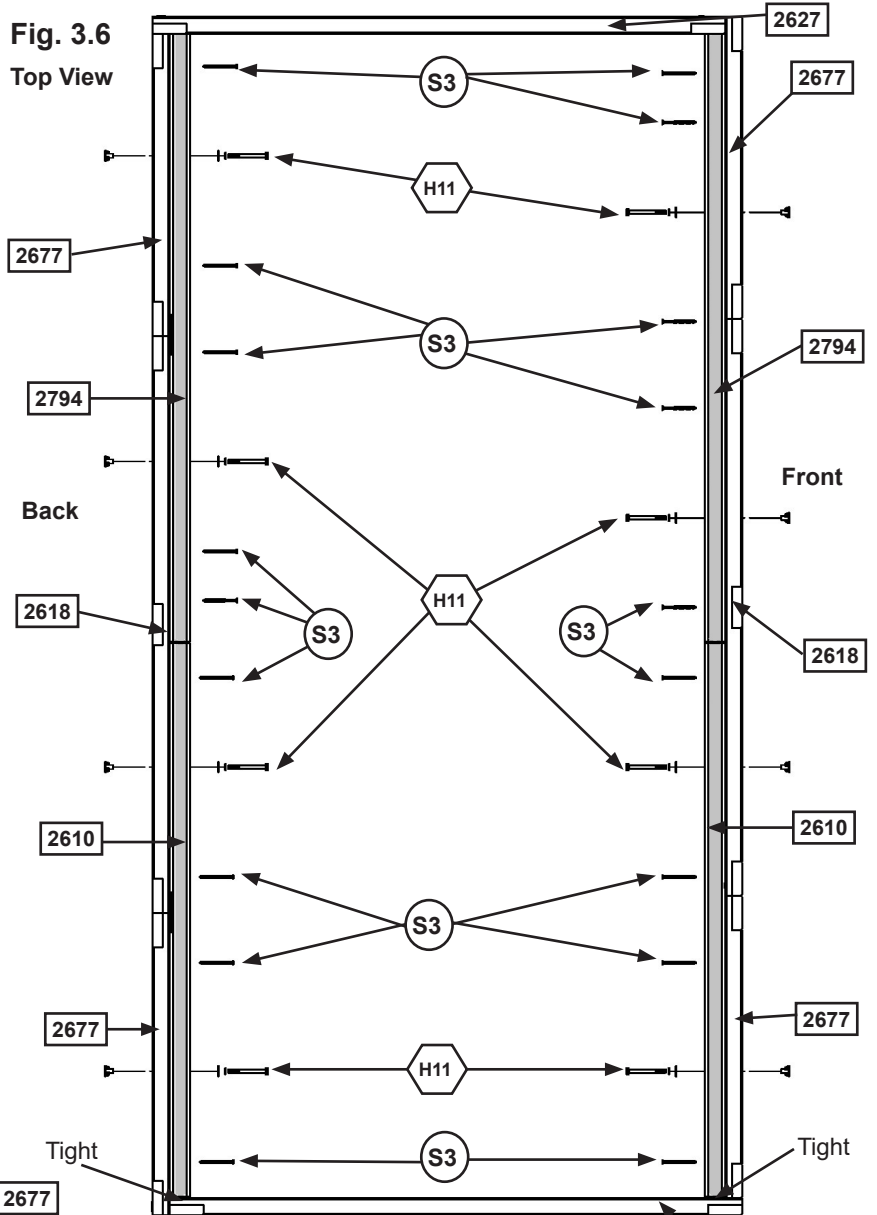


**E:** On the Back Wall, from inside the assembly, tight to (2622) End Panel Assembly, halfway up the assembly attach 1 (2610) Side Joist, 5/8" down from the panel floor, to (2677) Narrow Panel and (2618) Front Back Panel with 2 (H11) 1/4 x 2-3/4" Hex Bolts (with lock washer, flat washer and t-nut). Bolts are installed from inside the assembly. Make sure (2610) Side Joist is level then attach with 4 (S3) #8 x 2-1/2" Wood Screws. (fig. 3.6 and 3.7)

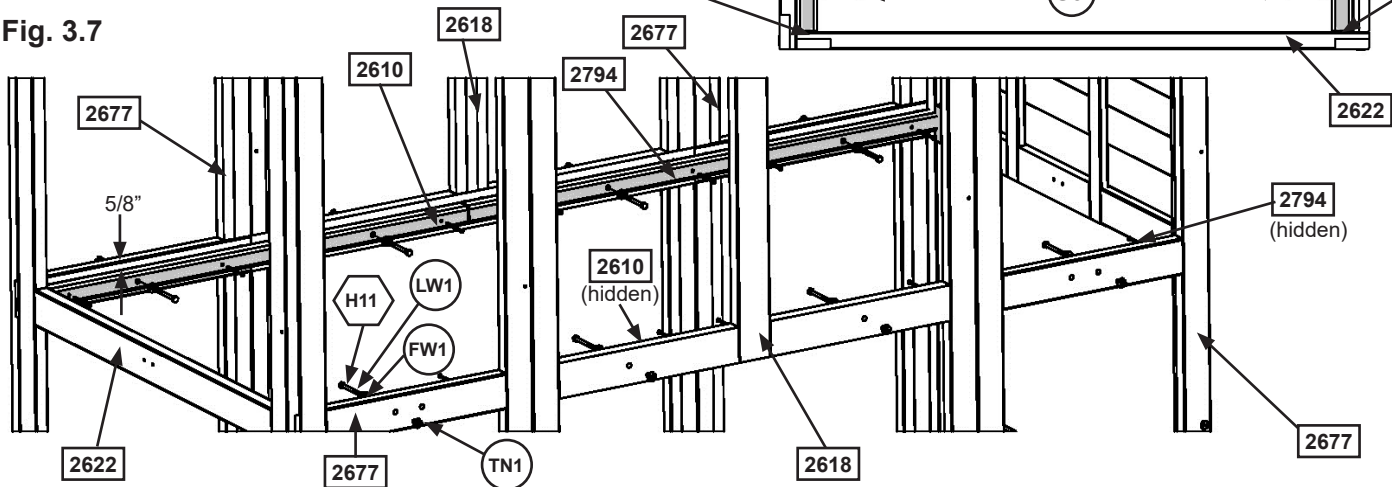
**F:** Tight to (2610) Side Joist attach (2794) Joist, 5/8" down from the panel floor, to (2618) Front Back Panel and (2677) Narrow Panel with 2 (H11) 1/4 x 2-3/4" Hex Bolts (with lock washer, flat washer and t-nut). Bolts are installed from inside the assembly. Make sure (2794) Joist is level and flush to the top of (2610) Side Joist then attach with 5 (S3) #8 x 2-1/2" Wood Screws. (fig. 3.6 and 3.7)

**G:** Repeat E and F for the Front Wall making sure to position (2794) Joist so it is opposite to the back wall. Notice screw and bolt locations. (fig. 3.6 and 3.7)

**Fig. 3.6**  
Top View



**Fig. 3.7**



**Wood Parts**

- 2 x 2610 Side Joist 2 x 2 x 40-1/4"
- 2 x 2794 Joist 2 x 2 x 44-3/8"

**Hardware**

- 18 x S3 #8 x 2-1/2" Wood Screw
- 8 x H11 1/4 x 2-3/4" Hex Bolt (LW1, FW1, TN1)

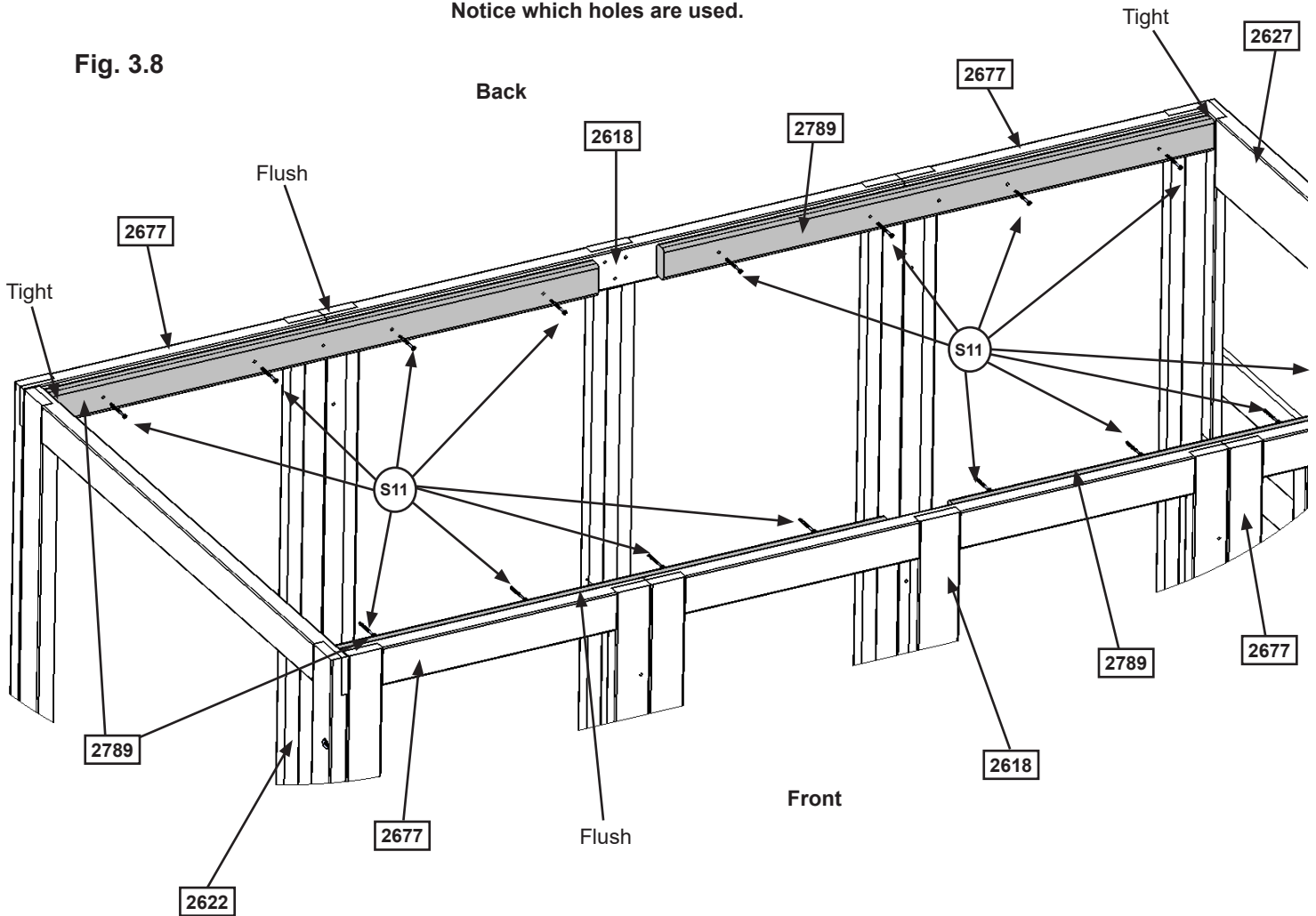
# Step 3: Join Frame Assemblies Part 5



**H:** From inside the assembly, flush to the top of the assembly place 1 (2789) Short Wall Tie tight to each side of (2622) End Panel Assembly and each side of (2627) SW Wall Panel then attach each to (2677) Narrow Panels and (2618) Front Back Panels on both the front and back walls with 4 (S11) #8 x 2" Wood Screws per board. (fig. 3.8)

Notice which holes are used.

Fig. 3.8



### Wood Parts

4 x 2789 Short Wall Tie 5/4 x 3 x 40"

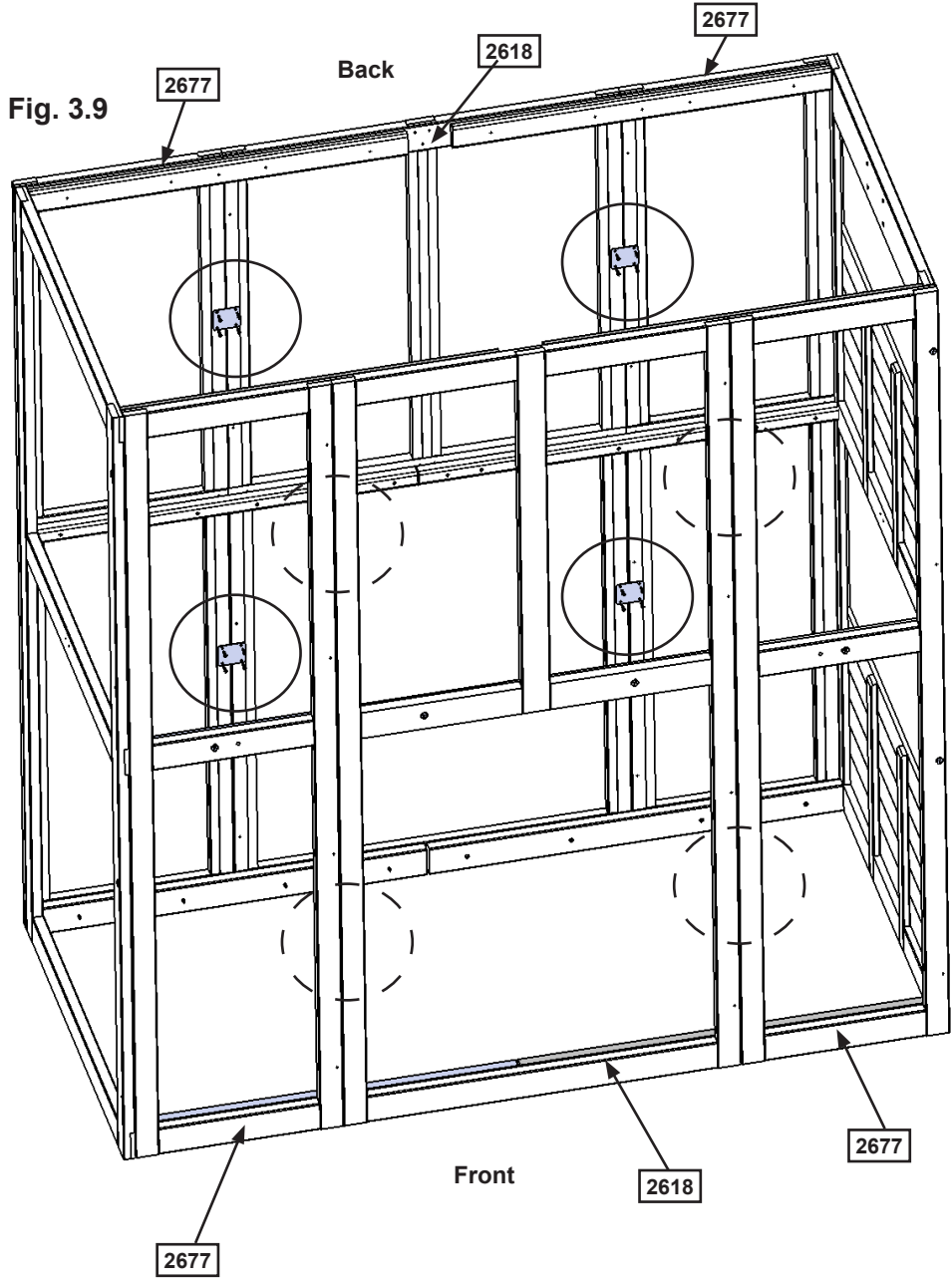
### Hardware

16 x S11 #8 x 2" Wood Screw

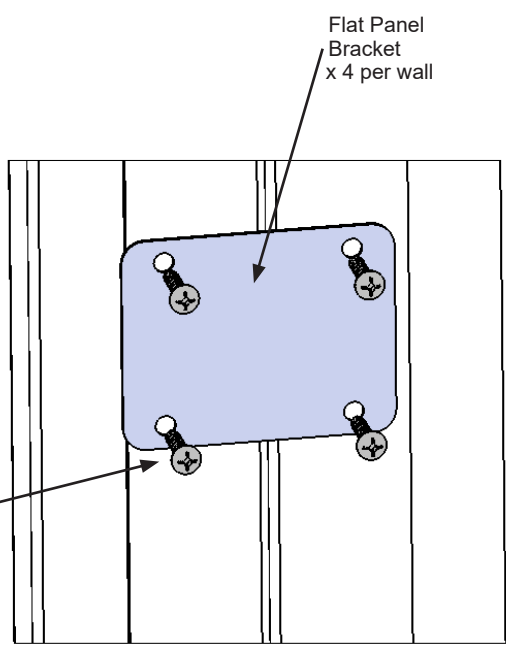
# Step 3: Join Frame Assemblies


## Part 6

I: On the inside of the assembly attach each (2677) Narrow Panel to (2618) Front Back Panel on both the front and back walls using 4 Flat Panel Brackets per wall in the places shown with 4 (S8) #12 x 3/4" Pan Screws per bracket. (fig. 3.9 and 3.10)



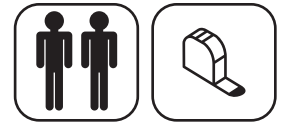
**Fig. 3.10**  
Inside View



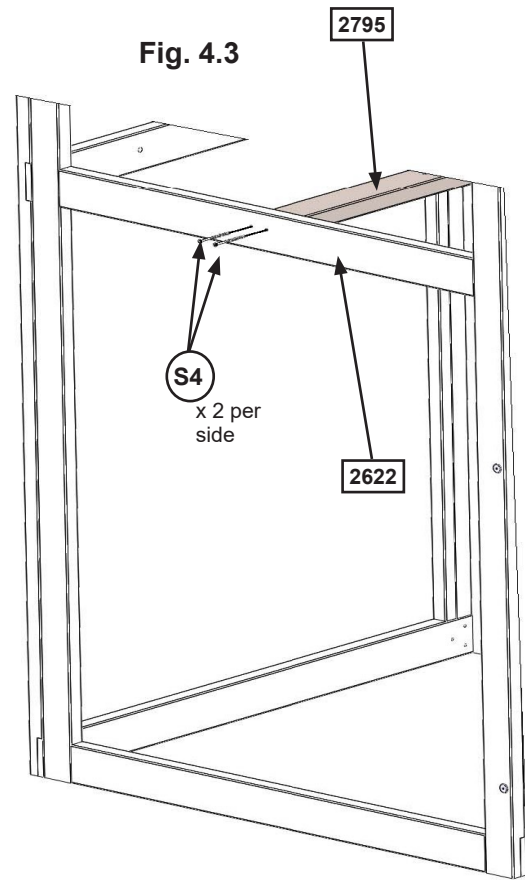
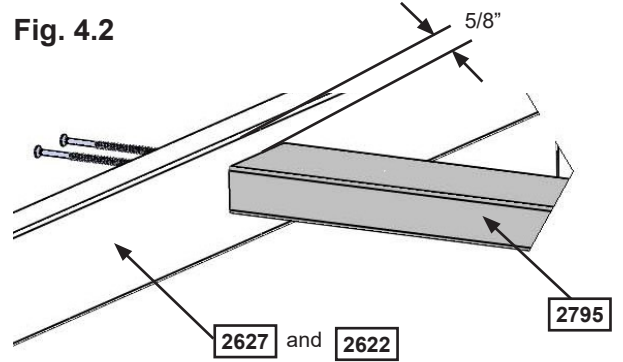
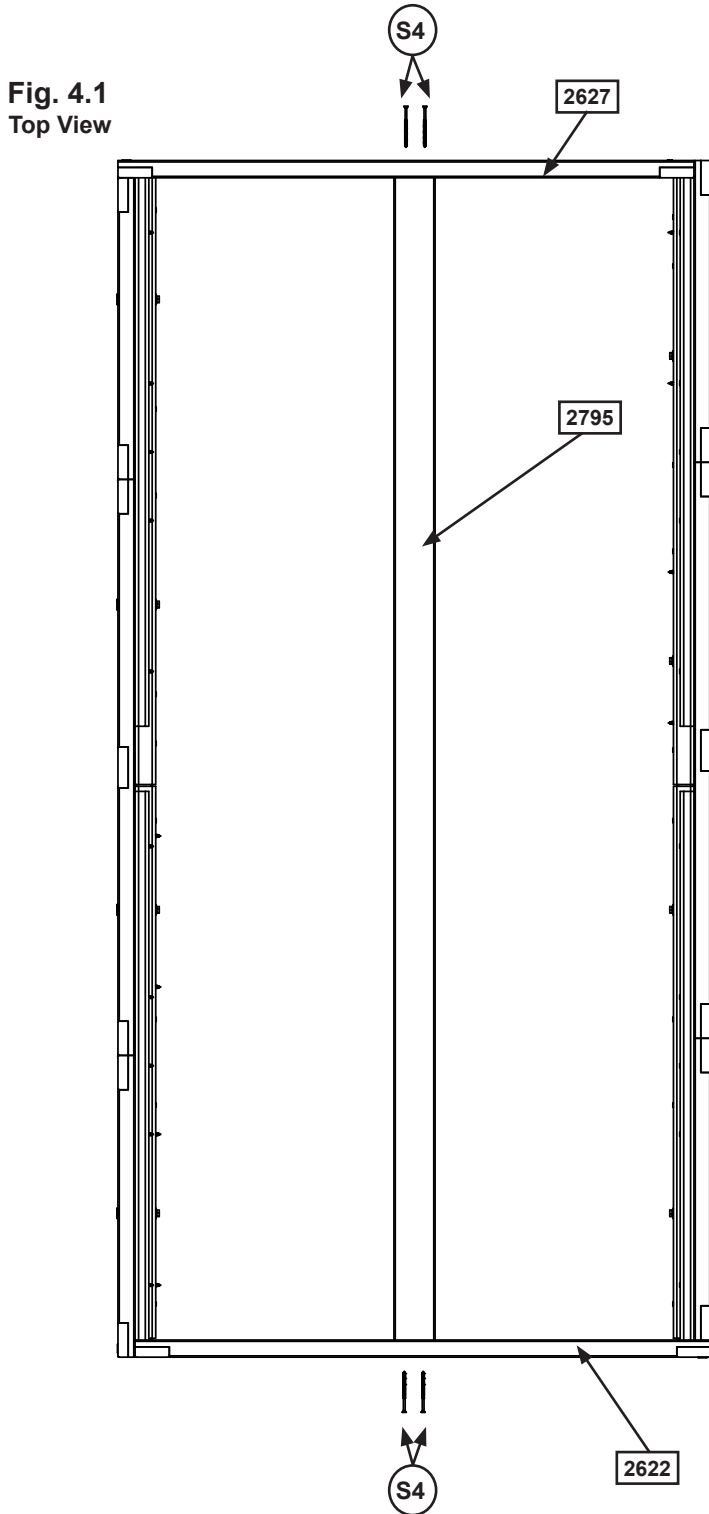
**Hardware**  
32 x  #12 x 3/4" Pan Screw

**Other Parts**  
8 x 3200641

# Step 4: Floor Assembly Part 1



**A:** From inside of the assembly center (2795) Long Joist over pilot holes in (2622) End Panel Assembly and (2627) SW Wall Panel, 5/8" down from the top of boards then attach (2795) Long Floor Joist to each panel with 2 (S4) #8 x 3" Wood Screws per end. (fig.4.1, 4.2 and 4.3)



### Wood Parts

1 x 2795 Long Joist 1-1/4 x 3 x 84-3/4"

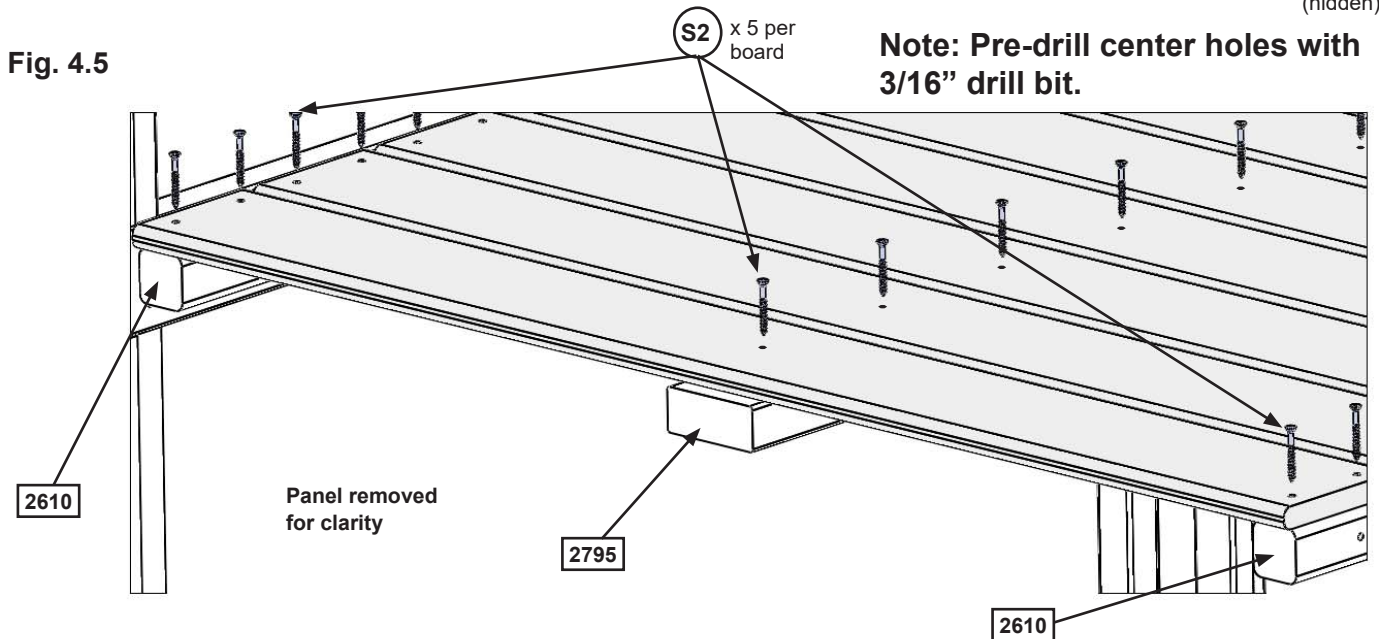
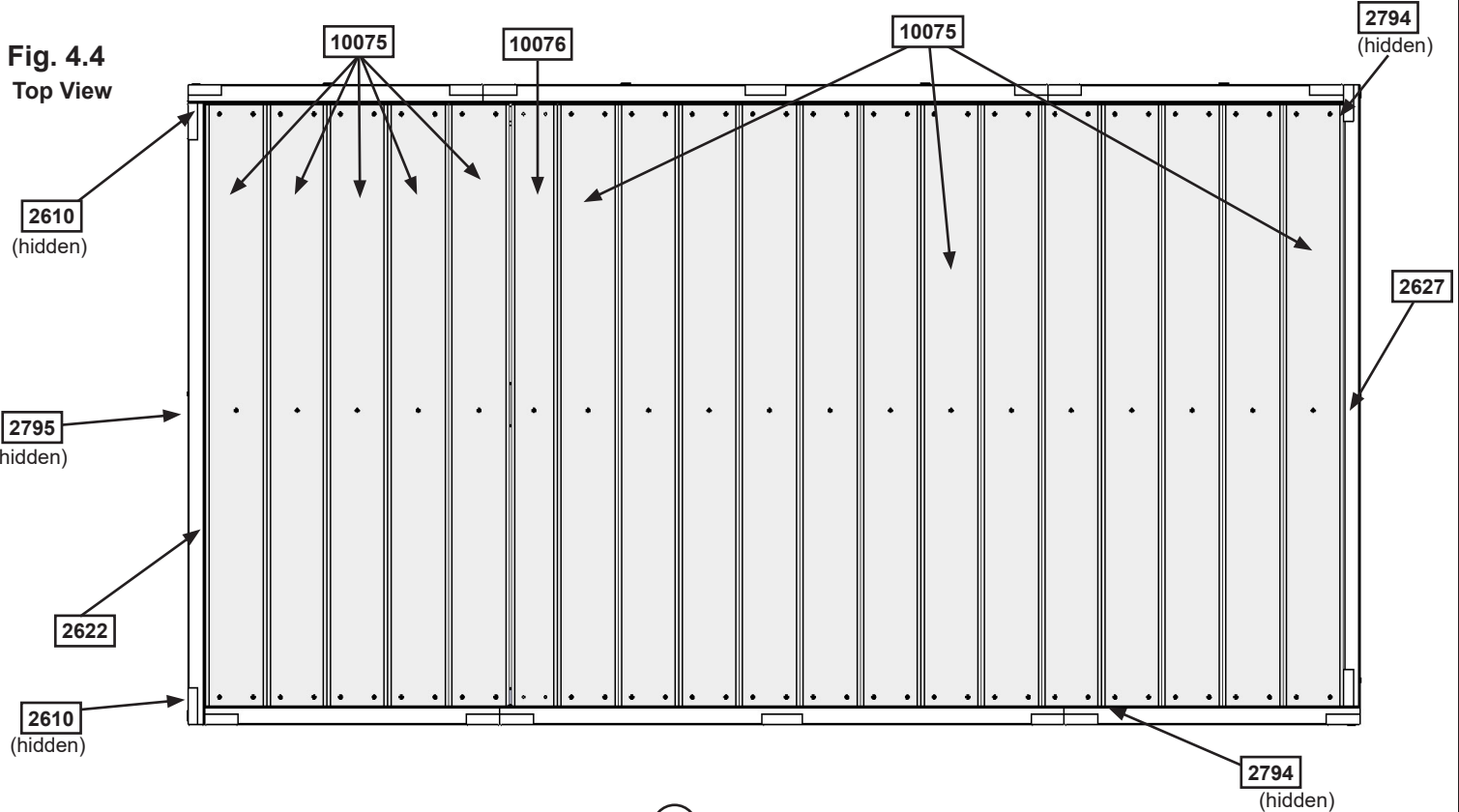
### Hardware

4 x S4 #8 x 3" Wood Screw

# Step 4: Floor Assembly Part 2



**B:** Starting at (2622) End Panel Assembly place 5 (10075) Floor Boards followed by 1 (10076) Floor Board then the remaining 13 (10075) Floor Boards. Make sure all boards are evenly spaced then attach to (2795) Long Joist and each (2610) Side Joist and (2794) Joist with 5 (S2) #8 x 1-1/2" Wood Screws per board. (fig. 4.4 and 4.5)



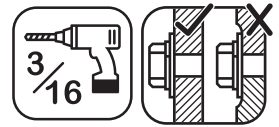
### Wood Parts

- 1 x 10076 Floor Board 1 x 4 x 40-5/8"
- 18 x 10075 Floor Board 1 x 5 x 40-5/8"

### Hardware

- 95 x S2 #8 x 1-1/2" Wood Screw

# Step 5: Attach SW Ground and Diagonal



**A:** Loosely attach 1 (2606) SW Ground to each (2607) Diagonal with 1 (H10) 1/4 x 2-1/4" Hex Bolt (with lock washer, flat washer and t-nut) per board then place each (2607) Diagonal tight and flush to the front of (2627) SW Wall Panel. (2606) SW Grounds to be flush to the bottom of (2627) SW Wall Panel. (fig. 5.1 and 5.2)

**B:** Pre-drill pilot hole with a 3/16" drill bit then attach each (2607) Diagonal to (2627) SW Wall Panel with 1 (LS3) 1/4 x 3" Lag Screw (with flat washer) per board, checking that they remain flush to outside edge. (fig. 5.1 and 5.2)

**C:** Make sure bottom of each (2606) SW Ground is flush to bottom of (2627) SW Wall Panel then attach with 2 (S11) #8 x 2" Wood Screws and 1 (S4) #8 x 3" Wood Screw per board. Tighten all bolts. (fig. 5.1 and 5.2)

Fig. 5.1

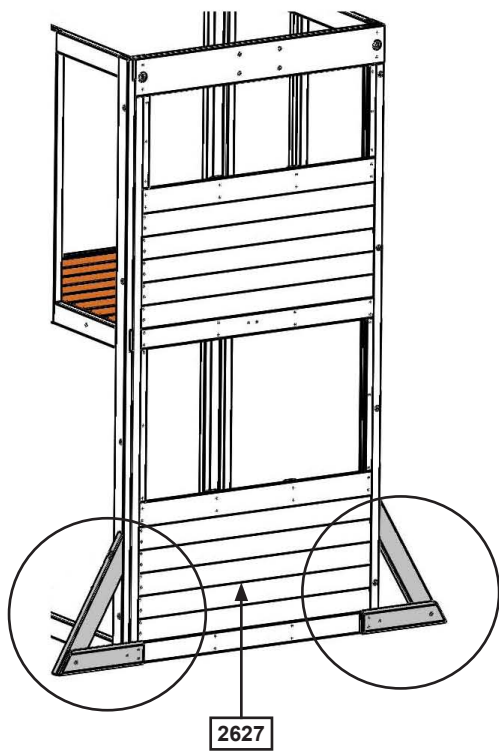
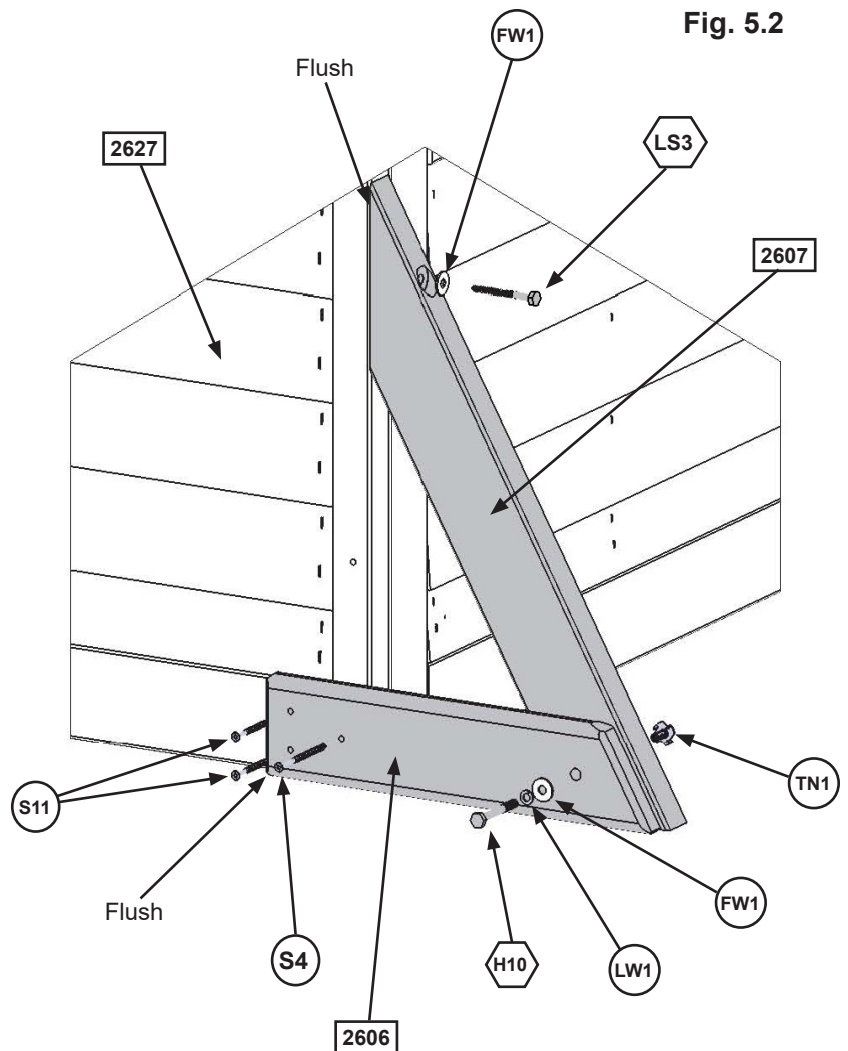


Fig. 5.2



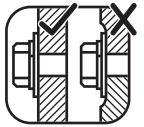
## Wood Parts

- 2 x 2606 SW Ground 5/4 x 4 x 14-1/4"
- 2 x 2607 Diagonal 1-1/4 x 3 x 22"

## Hardware

- 2 x H10 1/4 x 2-1/4" Hex Bolt (LW1, FW1, TN1)
- 2 x LS3 1/4 x 3" Lag Screw (FW1)
- 2 x S4 #8 x 3" Wood Screw
- 4 x S11 #8 x 2" Wood Screw





# Step 6: Swing Beam Assembly

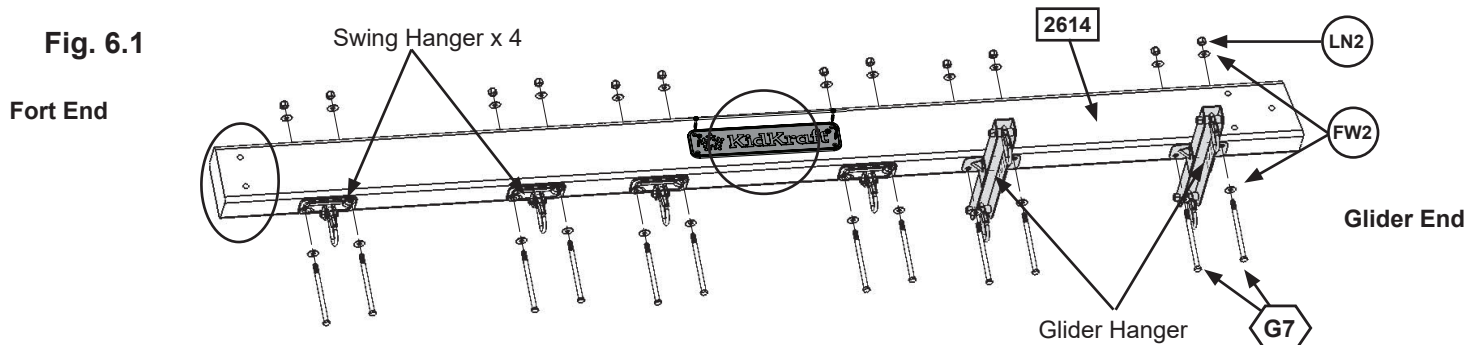
**A:** Attach 4 Swing Hangers to Fort End of (2614) Engineered Beam and 2 Glider Hangers to the Glider End using 2 (G7) 5/16 x 5-1/2" Hex Bolts (with 2 flat washers and 1 lock nut) per Swing Hanger and Glider Hanger, as shown in fig. 6.1.

**B:** Flush to the Fort End of (2614) Engineered Beam attach 2 L-Beam Brackets with 2 (G21) 5/16 x 3-3/4" Hex Bolts (with 2 flat washers and 1 lock nut). (fig. 6.2)

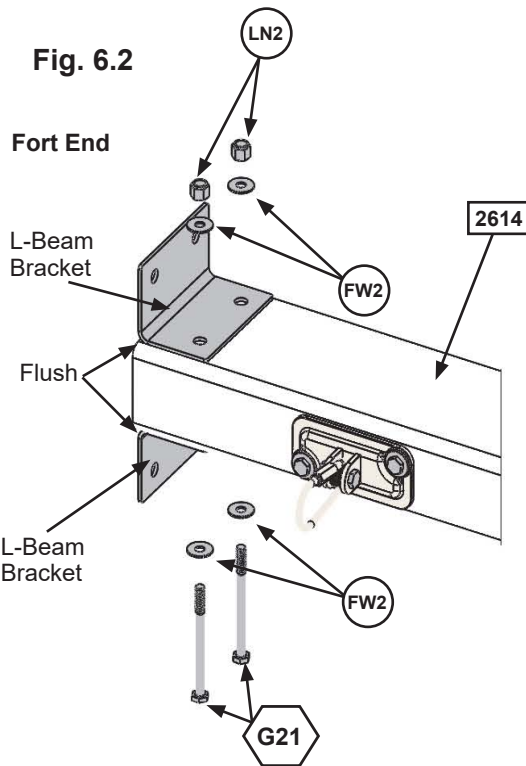
**C:** Install 1 (WB7) 5/16 x 3" Wafer Bolt (with flat washer and t-nut) in the middle bolt hole in (2614) Engineered Beam as shown in fig. 6.3. **IT IS IMPORTANT THAT THIS BOLT IS ATTACHED. IT WILL MINIMIZE CHECKING OF WOOD.**

**D:** Attach KidKraft Plaque to centre of (2614) Engineered Beam (over top of t-nut) using 4 (S18) #6 x 1" Wood Screws. (fig. 6.4)

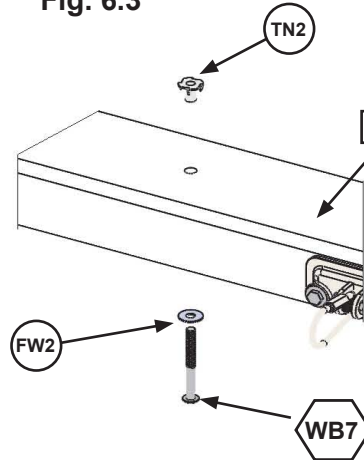
**Fig. 6.1**



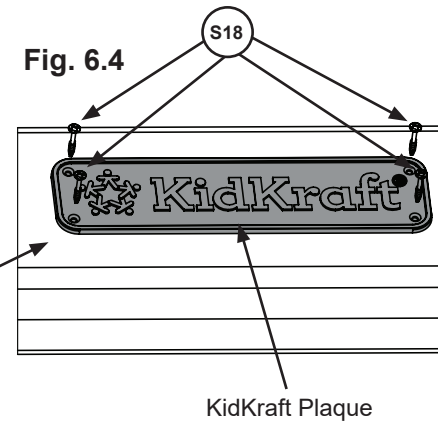
**Fig. 6.2**



**Fig. 6.3**



**Fig. 6.4**



**Wood Parts**

1 x **2614** Engineered Beam 4 x 6 x 88"

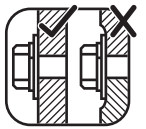
**Hardware**

- 12 x **G7** 5/16 x 5-1/2" Hex Bolt (FW2 x 2, LN2)
- 2 x **G21** 5/16 x 3-3/4" Hex Bolt (FW2 x 2, LN2)
- 1 x **WB7** 5/16 x 3" Wafer Bolt (FW2, TN2)
- 4 x **S18** #6 x 1" Wood Screw

**Other Parts**

- 4 x 9200106
- 1 x 3200105 (2pk)
- 1 x 3200145 (2pk)
- 1 x 3320353

# Step 7: Swing End Assembly

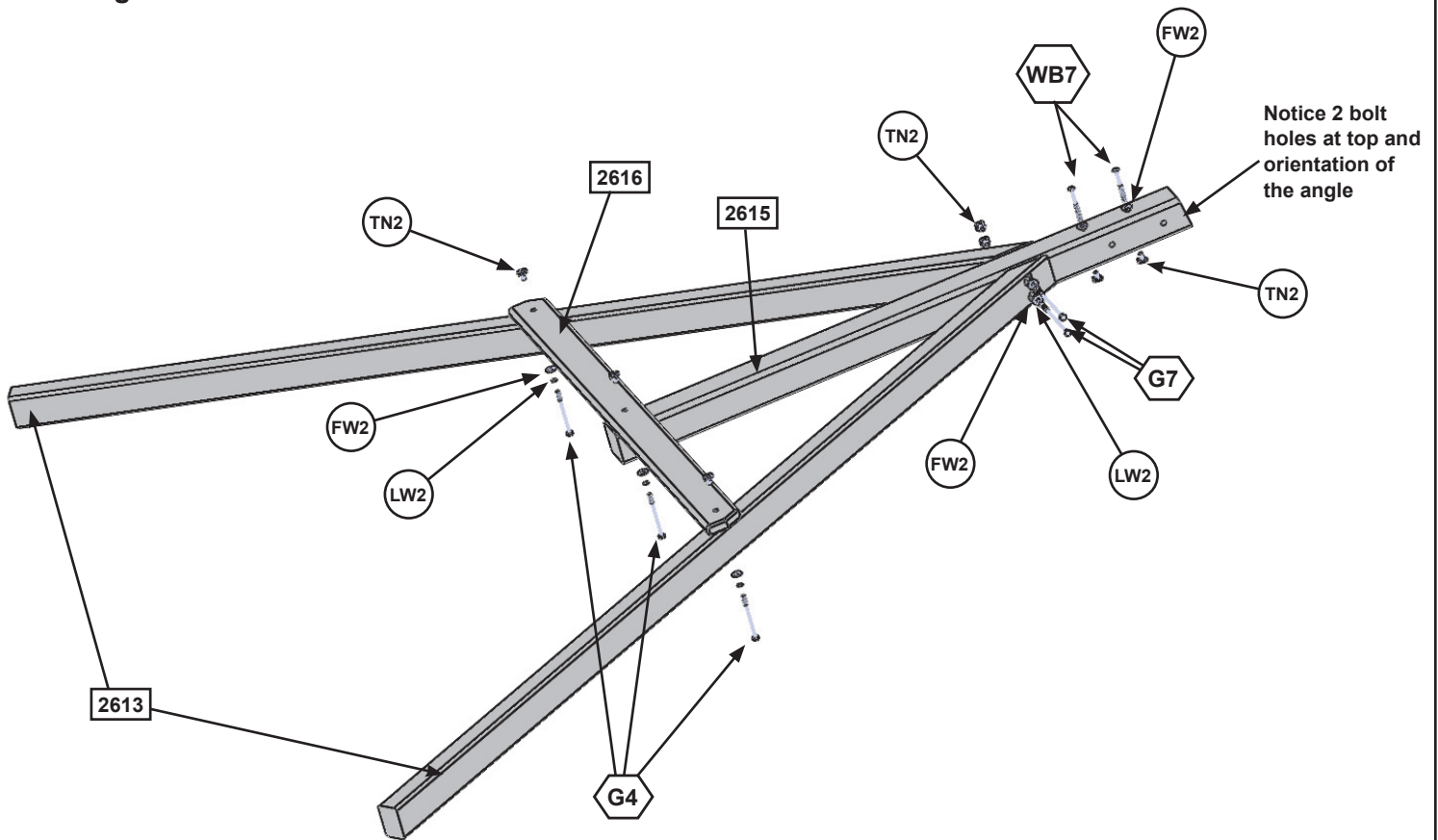


**A:** Loosely attach 2 (2613) Heavy SW Posts to (2615) SW Upright using 2 (G7) 5/16 x 5-1/2" Hex Bolts (with lock washer, flat washer and t-nut). Notice 2 bolt holes at top of (2615) SW Upright and orientation of angle. (fig. 7.1)

**B:** Attach (2616) SW Support to both (2613) Heavy SW Posts and (2615) SW Upright using 3 (G4) 5/16 x 4" Hex Bolts (with lock washer, flat washer and t-nut). Tighten all bolts (fig. 7.1)

**C:** Install 2 (WB7) 5/16 x 3" Wafer Bolts (with flat washer and t-nut) in the top bolt holes in (2615) SW Upright as shown in fig. 7.1. **IT IS IMPORTANT THAT THESE BOLTS ARE ATTACHED. THEY WILL MINIMIZE CHECKING OF WOOD.**

Fig. 7.1



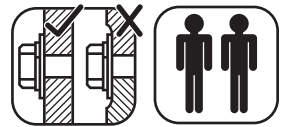
**Wood Parts**

- 2 x 2613 Heavy SW Post 2 x 3 x 86-11/16"
- 1 x 2615 SW Upright 4 x 4 x 50-15/16"
- 1 x 2616 SW Support 5/4 x 4 x 46-1/2"

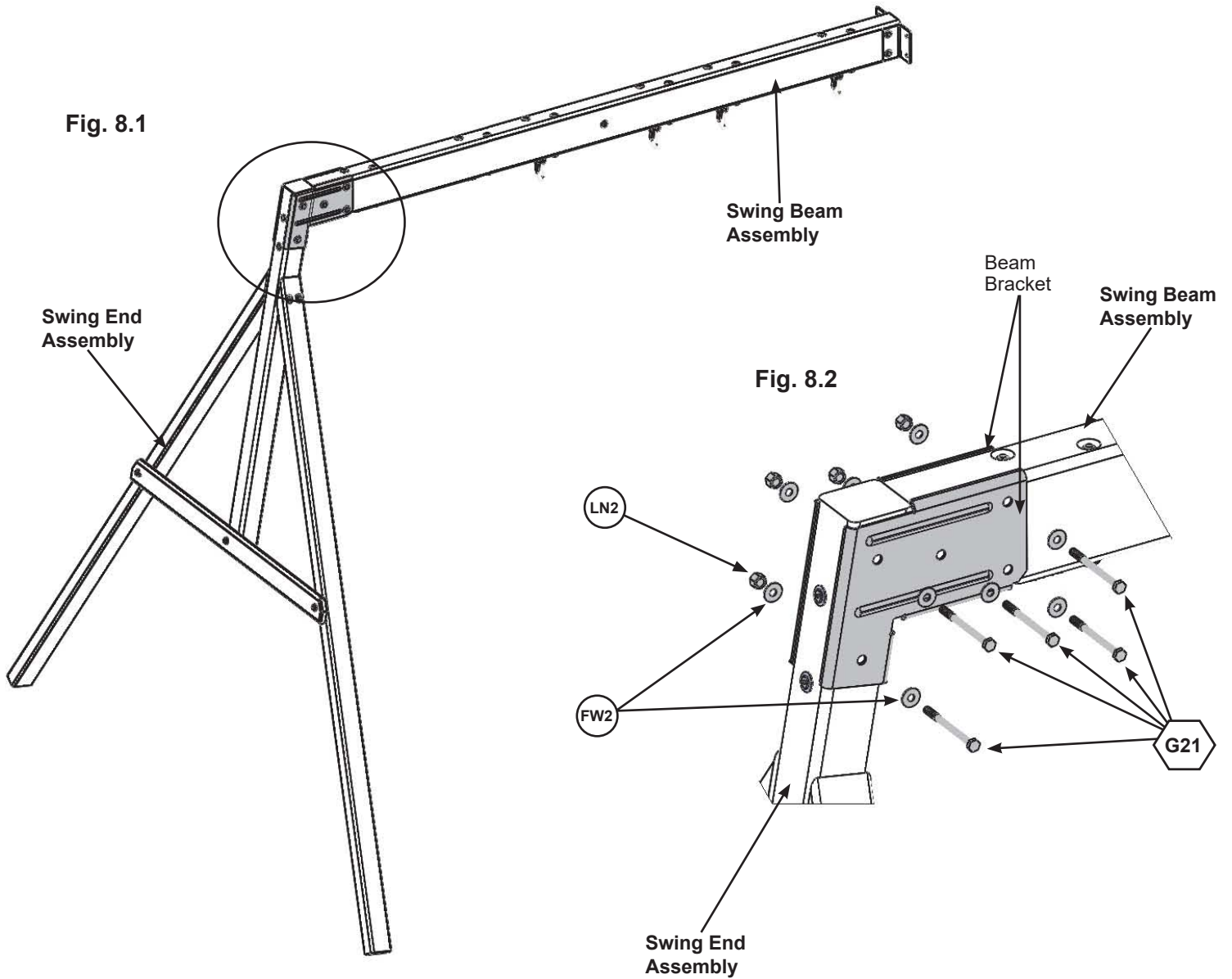
**Hardware**

- 2 x G7 5/16 x 5-1/2" Hex Bolt (LW2, FW2, TN2)
- 3 x G4 5/16 x 4" Hex Bolt (LW2, FW2, TN2)
- 2 x WB7 5/16 x 3" Wafer Bolt (FW2, TN2)

# Step 8: Attach Swing End to Swing Beam



**A:** Place Swing End Assembly against Swing Beam Assembly then place 1 Beam Bracket on each side of the assembly (they are specific for left and right side) and attach with 5 (G21) 5/16 x 3-3/4" Hex Bolts (with 2 flat washers and 1 lock nut). (fig. 8.1 and 8.2)



### Hardware

5 x  5/16 x 3-3/4" Hex Bolt (FW2 x 2, LN2)

### Other Parts

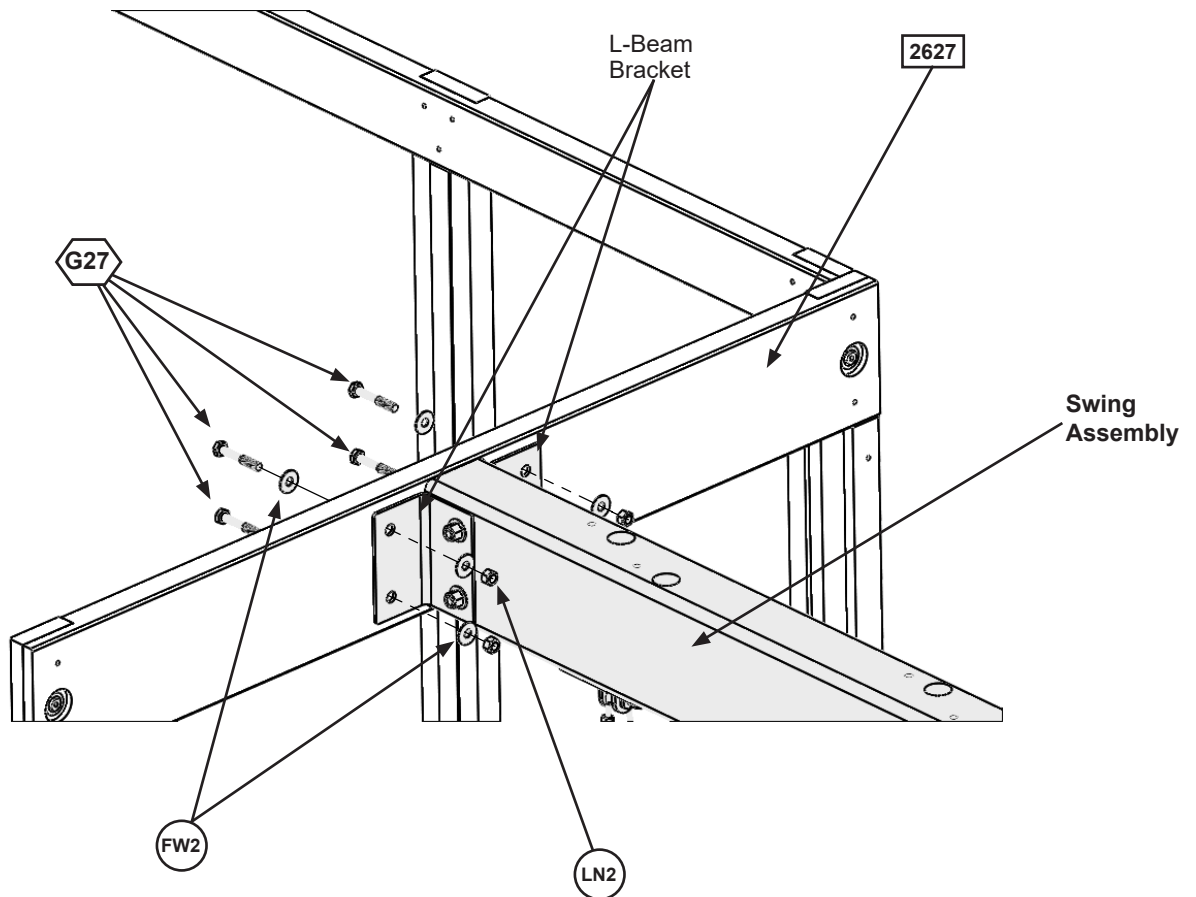
1 x 9200144  
1 x 9200143

## Step 9: Attach Swing Assembly To Fort




**A:** Place Swing Assembly against top of (2627) SW Wall Panel, make sure assembly is level then attach from inside the fort assembly into each L-Beam Bracket with 4 (G27) 5/16 x 1-3/4" Hex Bolts (with 2 flat washers and 1 lock nut). (fig. 9.1)

Fig. 9.1



### Hardware

4 x  5/16 x 1-3/4" Hex Bolt (FW2 x 2, LN2)

# Step 10: Install Ground Stakes

## **MOVE FORT TO FINAL LOCATION PRIOR TO STAKING** **FINAL LOCATION MUST BE LEVEL GROUND**

**A:** In the 5 places shown in fig. 10.1 drive the Rebar Ground Stakes 13" into the ground against outside front corner of (2622) End Panel Assembly, on both (2607) Diagonals and both (2613) Heavy SW Posts. Be careful not to hit the washer while hammering stakes into the ground as this could cause the washer to break off.

**B:** Attach ground stakes using 1 (S7) #12 x 2" Pan Screw per ground stake (fig. 10.2 and 10.3).

**C:** After driving stakes into the ground, check for sharp edges caused by the impact of the hammer. Smooth any sharp edges from impact area and touch up with outdoor paint.

**⚠ Warning!** To prevent tipping and avoid potential injury, stakes must be driven 13" into ground. Digging or driving stakes can be dangerous if you do not check first for under-ground wiring, cables or gas lines.

Fig. 10.1

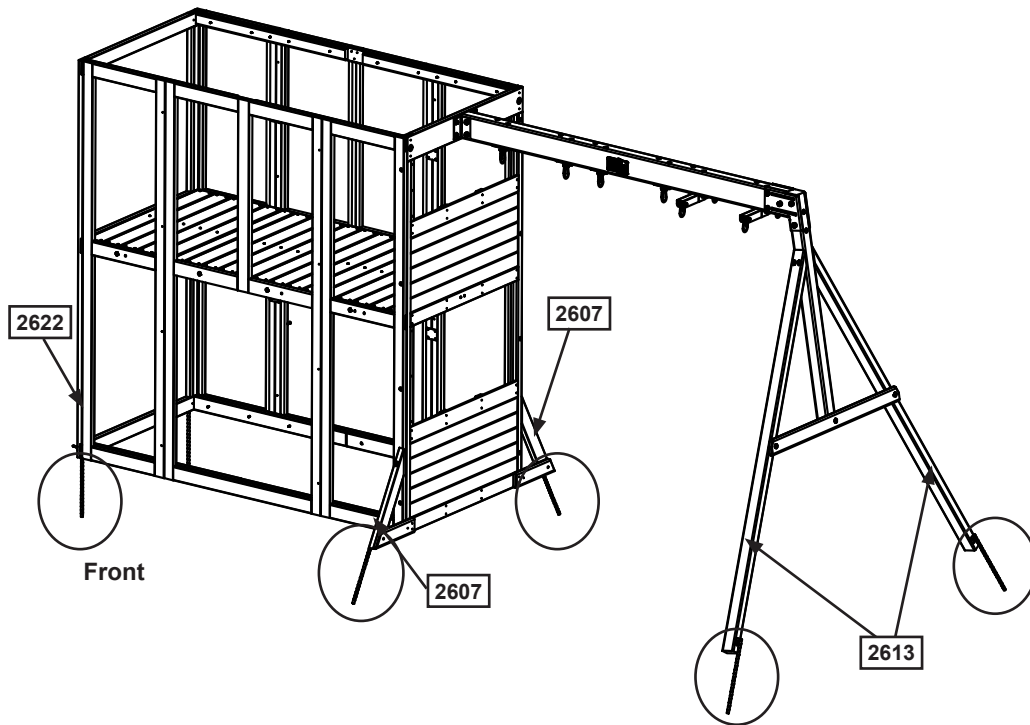


Fig. 10.2

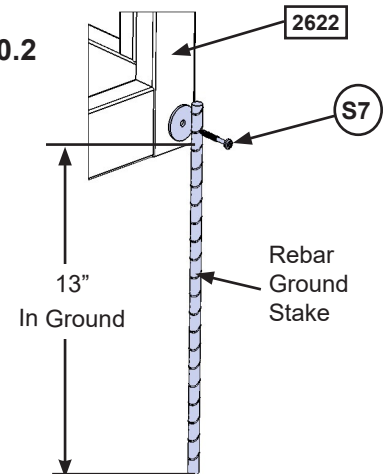
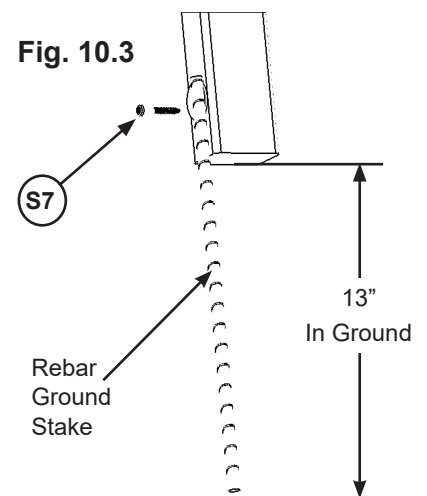


Fig. 10.3



### Hardware

5 x (S7) #12 x 2" Pan Screw

### Other Parts

5 x Rebar Ground Stake

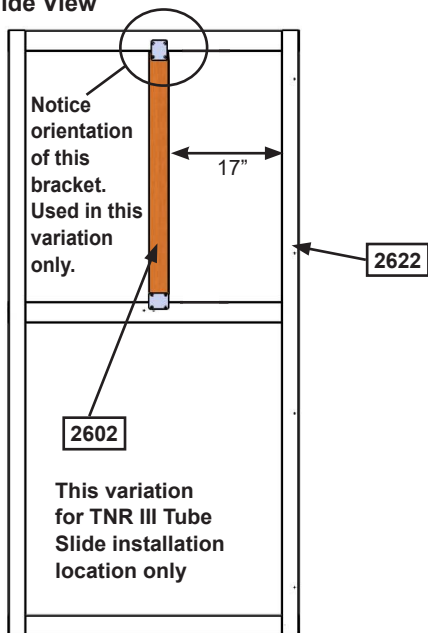
# Step 11: Install Upper and Lower Jambs



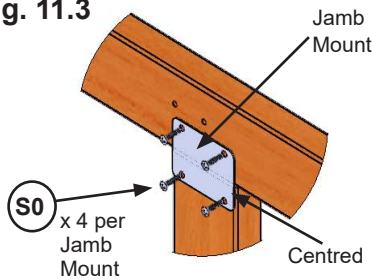
**A:** In the upper opening of (2622) End Panel Assembly place 1 (2602) Upper Jamb so it measures 17" to the inside of each post then attach with 2 Jamb Mounts using 4 (S0) #8 x 7/8" Truss Screws per mount. (fig. 11.1, 11.3, 11.4 and 11.5)

**B:** In the lower opening of (2622) End Panel Assembly and the front (2618) Front Back Panel place 1 (2601) Lower Jamb so it measures 17" to the inside of each post then attach each (2601) Lower Jamb with 2 Jamb Mounts using 4 (S0) #8 x 7/8" Truss Screws per mount. (fig. 11.2, 11.3, 11.4 and 11.5).

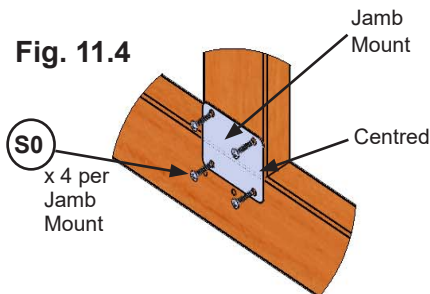
**Fig. 11.1**  
Outside View



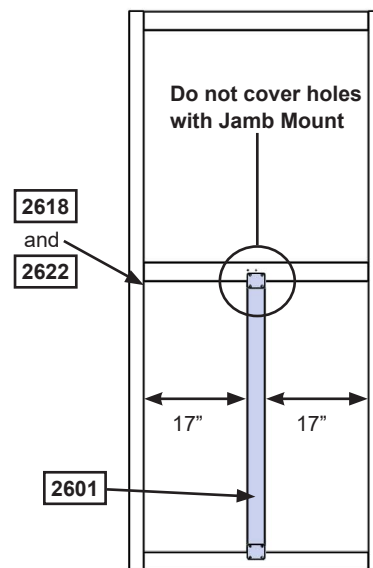
**Fig. 11.3**



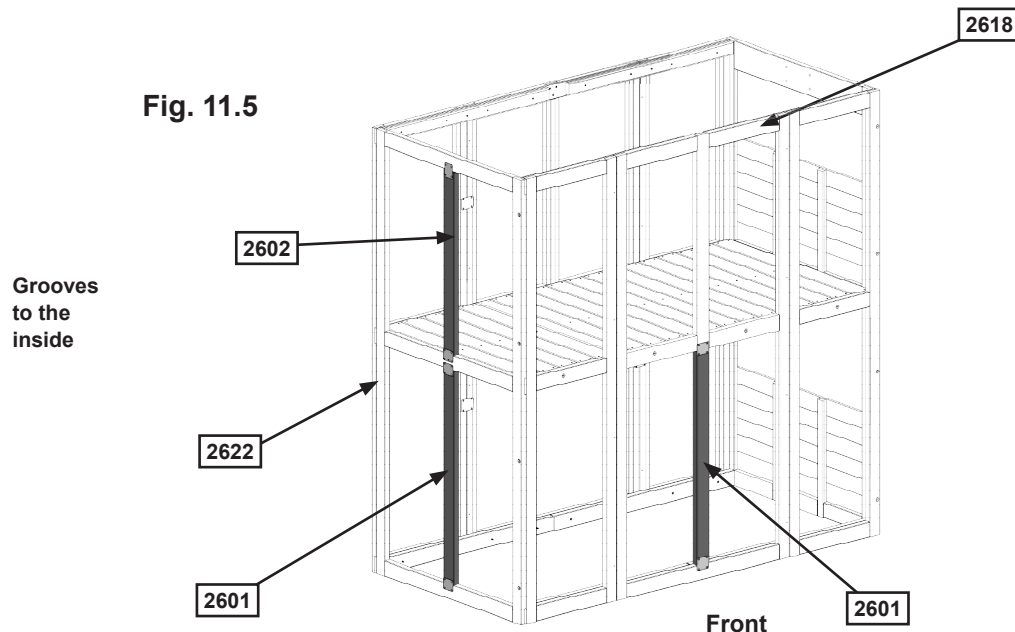
**Fig. 11.4**



**Fig. 11.2**  
Outside View



**Fig. 11.5**



**Wood Parts**

- 1 x 2602 Upper Jamb 1-1/4 x 3 x 35-15/16"
- 2 x 2601 Lower Jamb 1-1/4 x 3 x 41-15/16"

**Hardware**

- 24 x S0 #8 x 7/8" Truss Screw

**Other Parts**

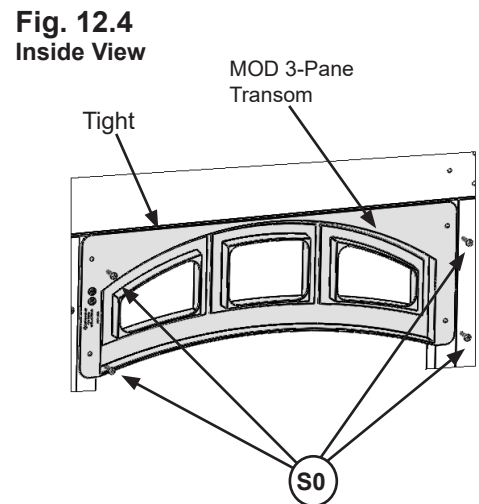
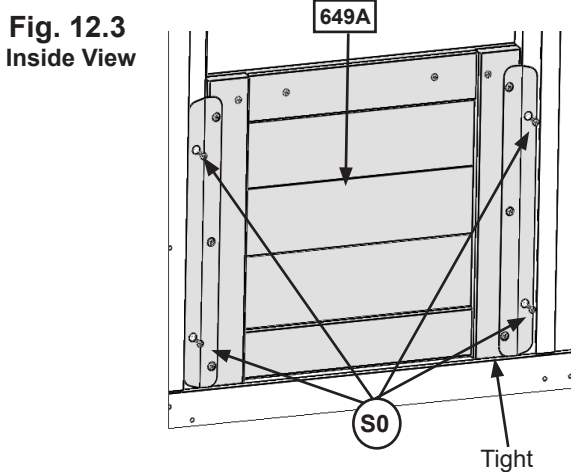
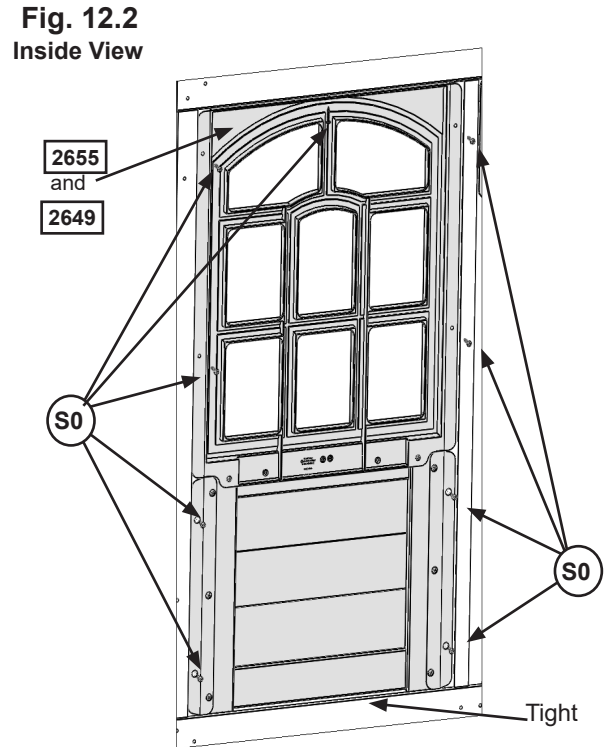
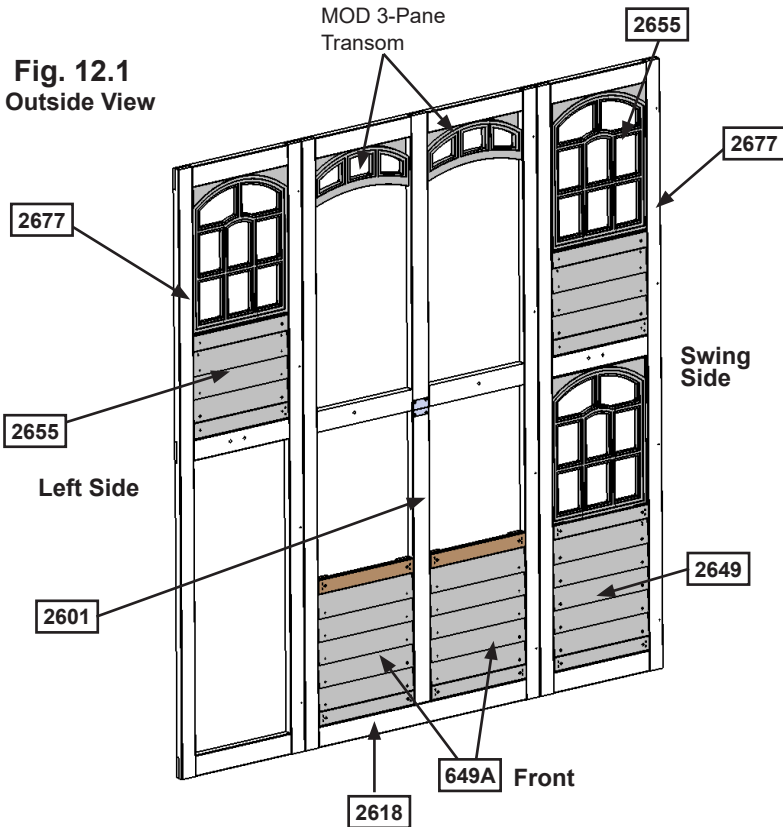
- 6 x Jamb Mount

# Step 12: Install Window and Wall Inserts

## Part 1 - Front Wall

**A:** On the Front of the assembly, in the openings of the (2677) Narrow Panels install 2 (2655) Upper Window Inserts in the upper openings and 1 (2649) Lower Window Insert in the lower opening on the Swing Side using 9 (S0) #8 x 7/8" Truss Screws per insert. (fig. 12.1 and 12.2)

**B:** On the Front of the assembly in the openings of the (2618) Front Back Panel install 2 (649A) Short Half Walls in the lower openings and 2 MOD 3-Pane Transoms in the upper openings with 4 (S0) #8 x 7/8" Truss Screws per insert. (fig. 12.1, 12.3 and 12.4)



### Wood Parts

- 2 x 2655 Upper Window Insert 1.27 x 18.8 x 35.86"
- 1 x 2649 Lower Window Insert 1.27 x 18.8 x 41.91"
- 2 x 649A Short Half Wall 1.27 x 18.8 x 20-15/16"

### Hardware

- 43 x S0 #8 x 7/8" Truss Screw

### Other Parts

- 2 x MOD 3-Pane Transom

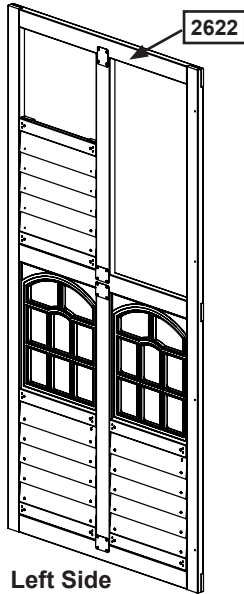
# Step 12: Install Window and Wall Inserts

## Part 2 - Left Side

**C:** In the lower openings of (2622) End Panel Assembly install 2 (2649) Lower Window Inserts with 9 (S0) #8 x 7/8" Truss Screws per insert. (fig. 12.5, 12.6 and 12.7)

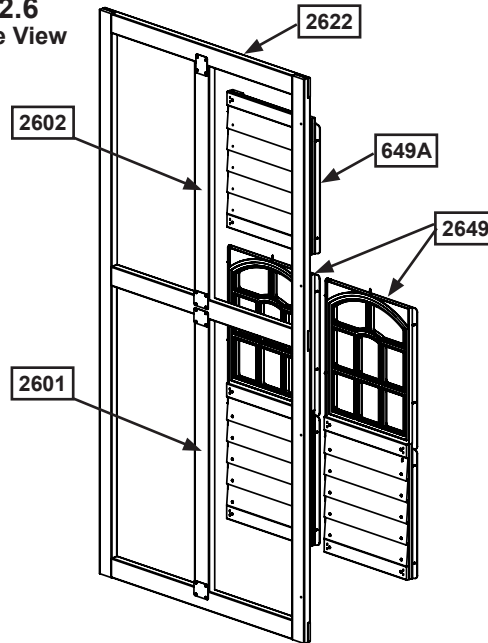
**D:** In the upper left opening of (2622) End Panel Assembly install 1 (649A) Short Half Wall with 4 (S0) #8 x 7/8" Truss Screws.(fig. 12.5, 12.6 and 12.8)

**Fig. 12.5**

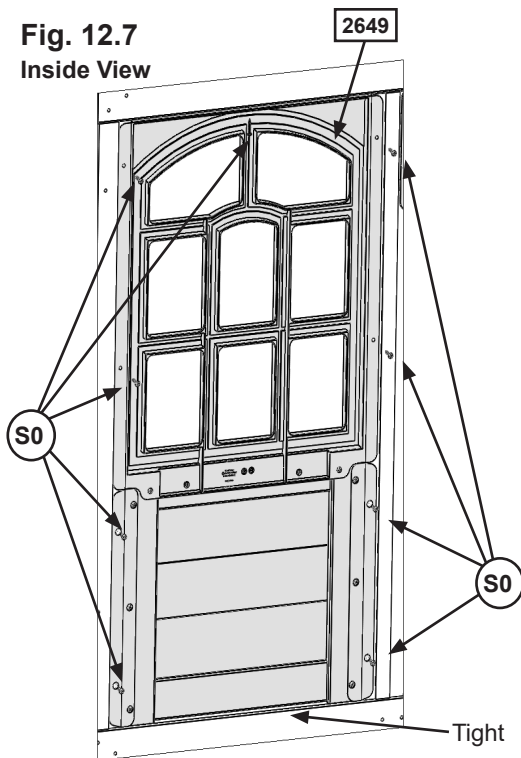


Left Side

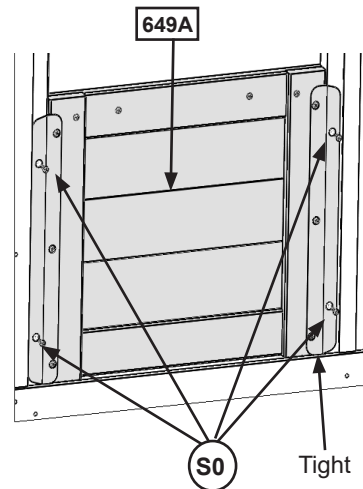
**Fig. 12.6**  
Outside View



**Fig. 12.7**  
Inside View



**Fig. 12.8**  
Inside View



### Wood Parts

2 x 2649 Lower Window Insert 1-1/4 x 18-7/8 x 41-15/16"

1 x 649A Short Half Wall 1-1/4 x 18-7/8 x 20-15/16"

### Hardware

22 x S0 #8 x 7/8" Truss Screw



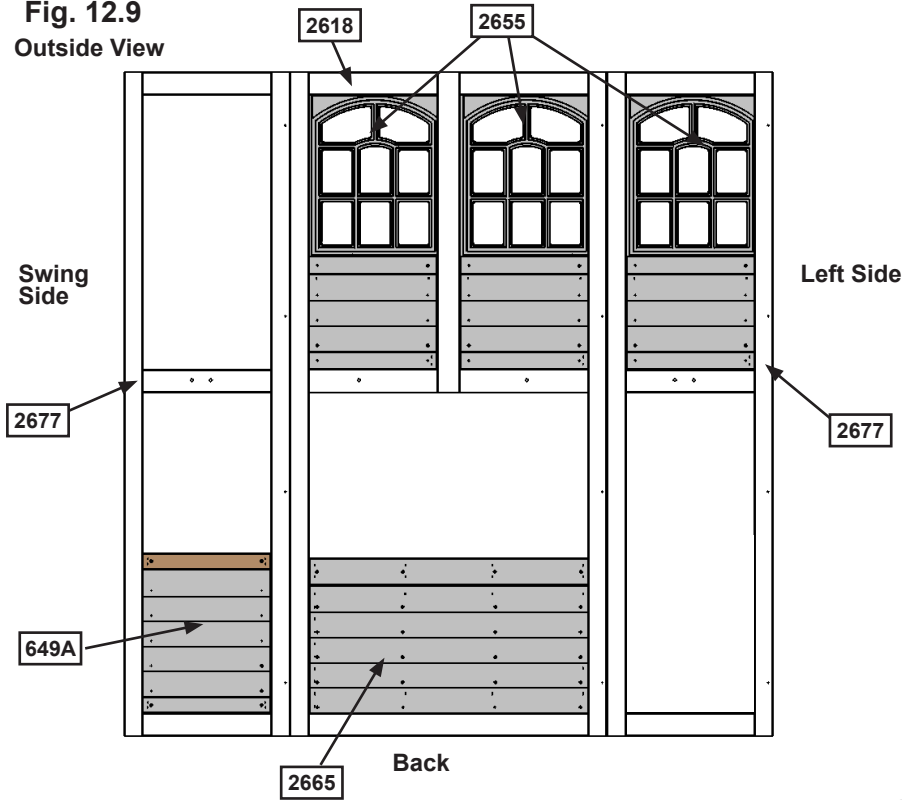
# Step 12: Install Window and Wall Inserts

## Part 3 - Back Wall

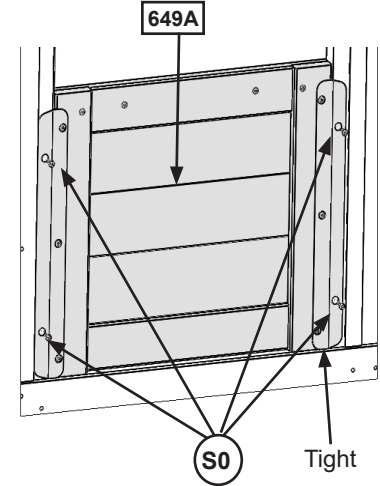
**E:** On the Back of the assembly, install 1 (649A) Short Half Walls in the lower opening of the right (2677) Narrow Panel and 1 (2665) Half Wall Insert in the lower openings of (2618) Front Back Panel using 4 (S0) #8 x 7/8" Truss Screws per insert. (fig. 12.9, 12.10 and 12.11)

**F:** Install 3 (2655) Upper Window Inserts in the upper openings of (2618) Front Back Panel and the Left Side (2677) Narrow Panel using 9 (S0) #8 x 7/8" Truss Screws per insert. (fig. 12.9 and 12.12)

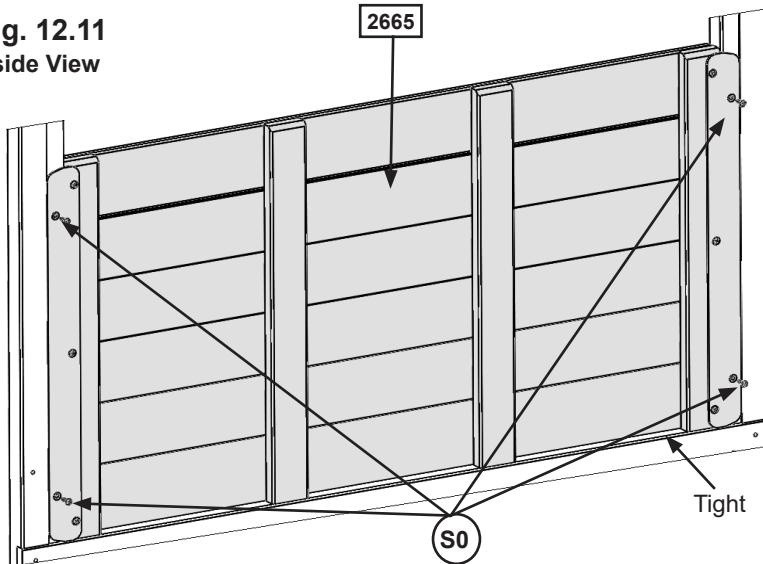
**Fig. 12.9**  
Outside View



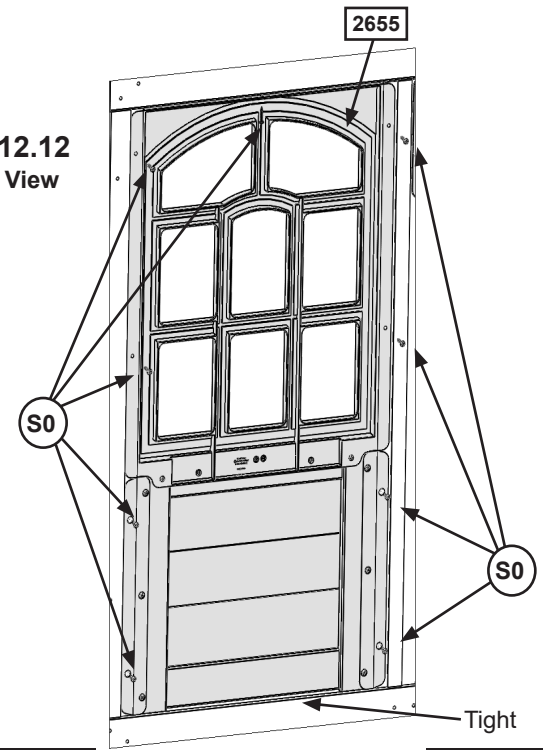
**Fig. 12.10**  
Inside View



**Fig. 12.11**  
Inside View



**Fig. 12.12**  
Inside View



### Wood Parts

- 3 x 2655 Upper Window Insert 1.27 x 18.8 x 35.86"
- 1 x 2665 Half Wall Insert 1.4 x 20-1/4 x 38.8"
- 1 x 649A Short Half Wall 1.27 x 18.8 x 20-15/16"

### Hardware

- 39 x S0 #8 x 7/8" Truss Screw

# Step 13: Clock Assembly

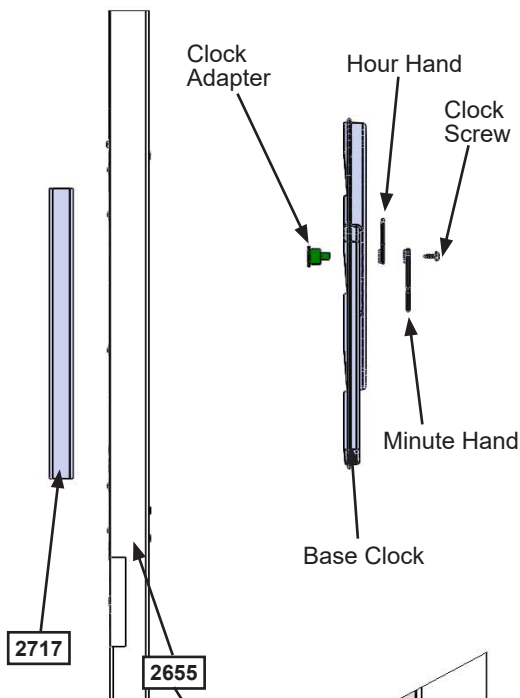


**A:** From the back of the Base Clock insert the Clock Adapter then from the front of the Base Clock place the Hour Hand over the Clock Adapter making sure they line up properly. Press the Minute Hand over the Hour Hand and connect with the Clock Screw. (fig. 13.1)

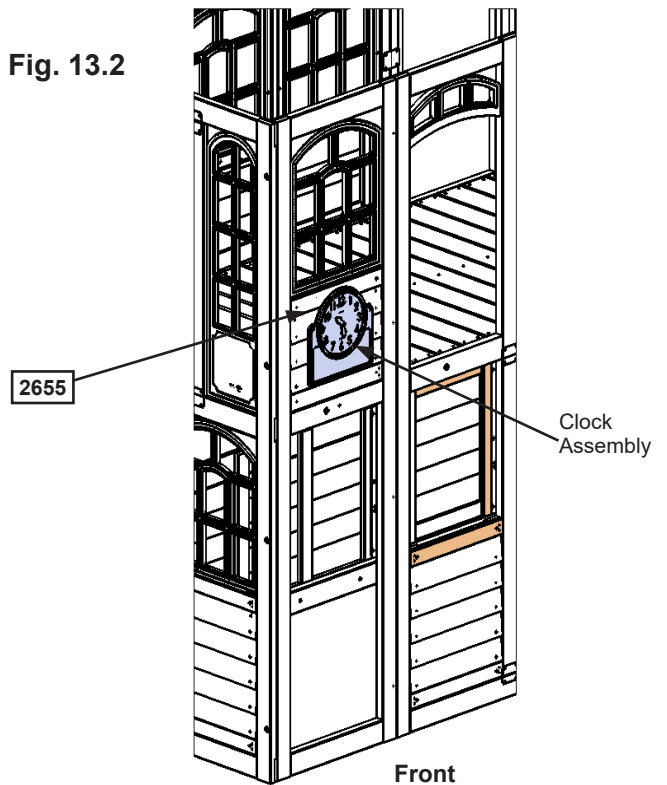
**B:** On the Front of the Assembly place Clock Assembly centred under window of the Slide Side (2655) Upper Window Insert then with a helper attach through insert and into each (2717) Clock Block with 4 (S2) #8 x 1-1/2" Wood Screw, 2 per block. (fig. 13.2, 13.3 and 13.4)

**Do not over tighten screws.**

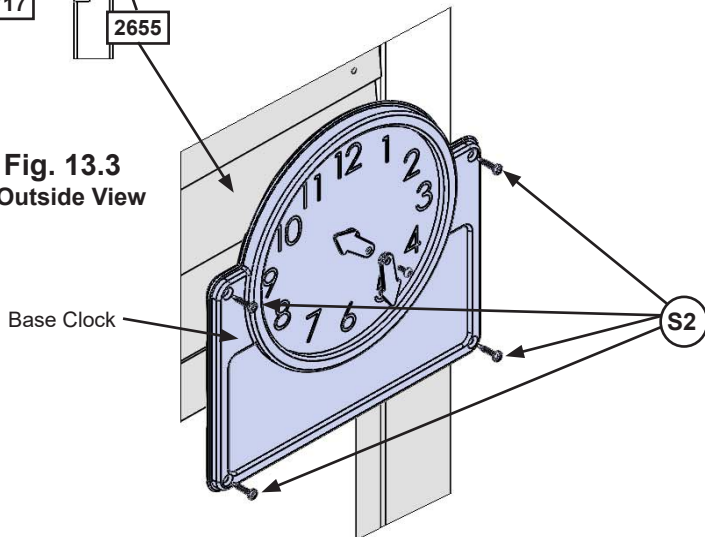
**Fig. 13.1**  
Side View



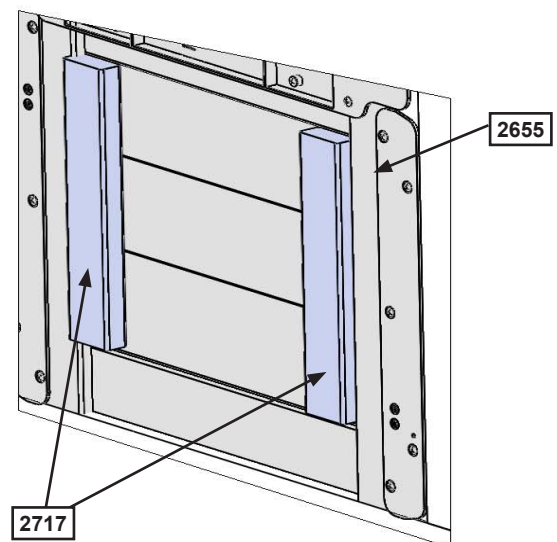
**Fig. 13.2**



**Fig. 13.3**  
Outside View



**Fig. 13.4**  
Inside View



**Wood Parts**

2 x 2717 Clock Block 3/4 x 1-3/4 x 9-3/4"

**Hardware**

4 x S2 #8 x 1-1/2" Wood Screw

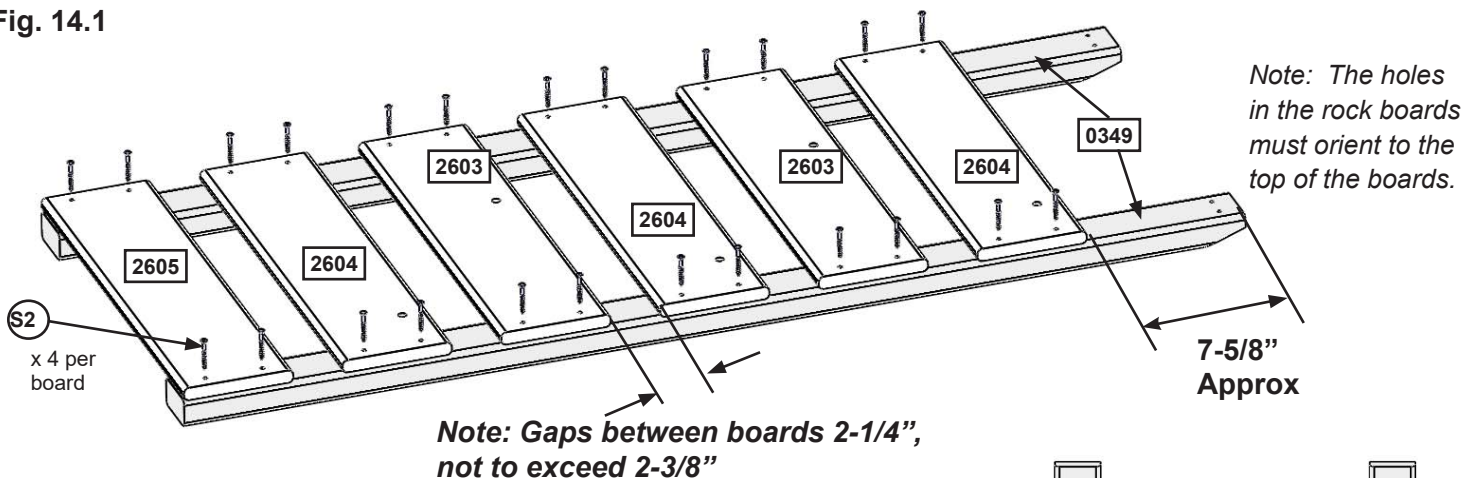
**Other Parts**

1 x Base Clock  
1 x Clock Subset  
1 x Clock Adapter  
1 x Hour Hand  
1 x Minute Hand  
1 x Clock Screw

# Step 14: Rock Wall Assembly



Fig. 14.1



Note: The holes in the rock boards must orient to the top of the boards.

Note: Gaps between boards 2-1/4", not to exceed 2-3/8"

**A:** Lay 2 (0349) Rock Rails down, side by side with angled edges facing down. (fig. 14.1)

**B:** Place (2605) Access Board on the bottom of each (0349) Rock Rail as shown in fig. 14.1. Make sure (2605) Access Board is flush to the outside and bottom edges of each (0349). Attach using 4 (S2) #8 x 1-1/2" Wood Screws.

**C:** 7-5/8" down from the top of both (0349) Rock Rails place 1 (2604) Rock Board B, making sure the sides are flush to the outside edges of each (0349) Rock Rail. Attach using 4 (S2) #8 x 1-1/2" Wood Screws. (fig. 14.1)

**D:** In between the (2605) Access Board and (2604) Rock Board B stagger 2 (2604) Rock Board Bs and 2 (2603) Rock Board As using 4 (S2) #8 x 1-1/2" Wood Screws per board. Placing them as shown in fig. 14.1, this will prevent rocks from forming a straight line. Make sure the boards are evenly spaced and do not exceed 2-3/8" between boards.

Fig. 14.2

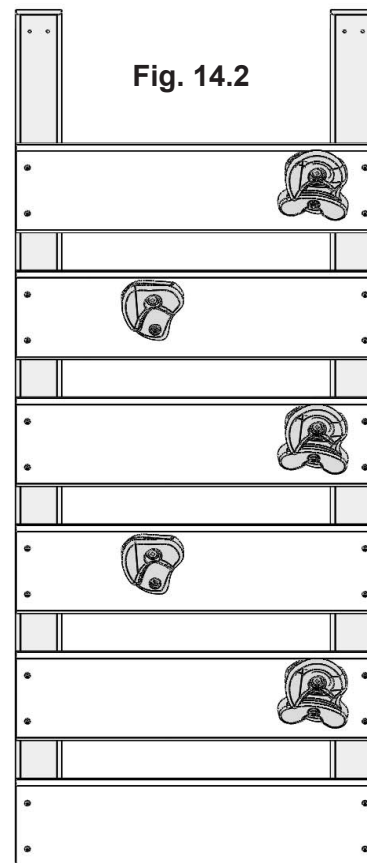
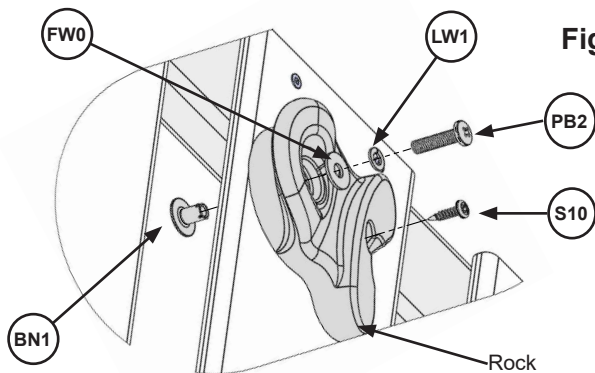


Fig. 14.3



**E:** Place 1 rock on each (2603) Rock Board A and (2604) Rock Board B (fig. 14.2) and attach using 1 (PB2) 1/4 x 1-1/4" Pan Bolt (with lock washer, flat washer and barrel nut) and 1 (S10) #8 x 1" Pan Screw per rock. The Screw must be in the hole directly under the Pan Bolt, it will stop the rock from spinning. (fig. 14.3)

**Wood Parts**

- 1 x 2605 Access Board 1 x 6 x 19-3/4"
- 3 x 2604 Rock Board B 1 x 6 x 19-3/4"
- 2 x 2603 Rock Board A 1 x 6 x 19-3/4"
- 2 x 0349 Rock Rail 2 x 3 x 51"

**Hardware**

- 24 x S2 #8 x 1-1/2" Wood Screw
- 5 x S10 #8 x 1" Pan Screw
- 5 x PB2 1/4 x 1-1/4 Pan Bolt (LW1, FW0, BN1)

**Other Parts**

- 5 x 3320386 (3 green/2 yellow)

# Step 15: Attach Rock Wall Assembly to Fort

## Part 1

**A:** Place Rock Wall Assembly centred in opening shown on the Fort Guide at the end of the instructions and flush as shown below. Attach (0349) Rock Rails using 4 (S11) #8 x 2" Wood Screws. (fig. 15.1 and 15.2)

**B:** Attach 1 (2605) Access Board to top of Rock Wall Assembly, flush to top of (0349) Rock Rail using 4 (S2) #8 x 1-1/2" Wood Screws. (fig. 15.3)

Fig. 15.1

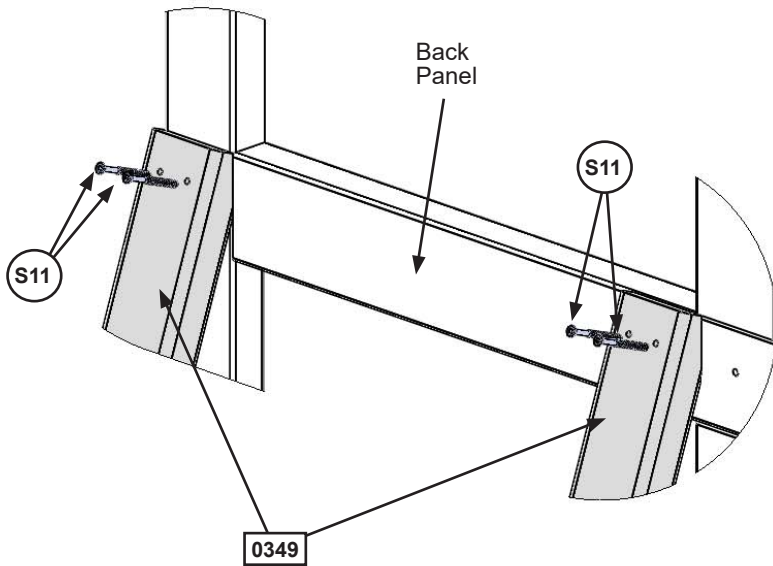


Fig. 15.2

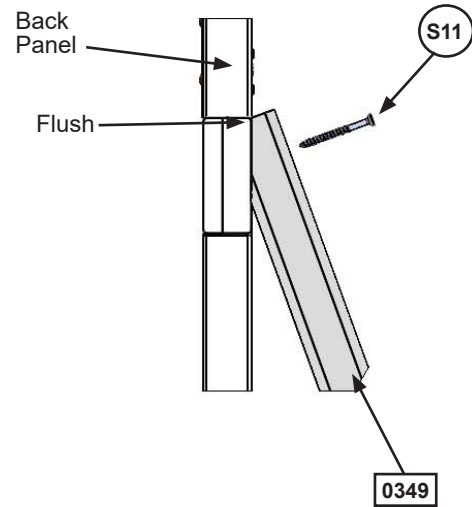
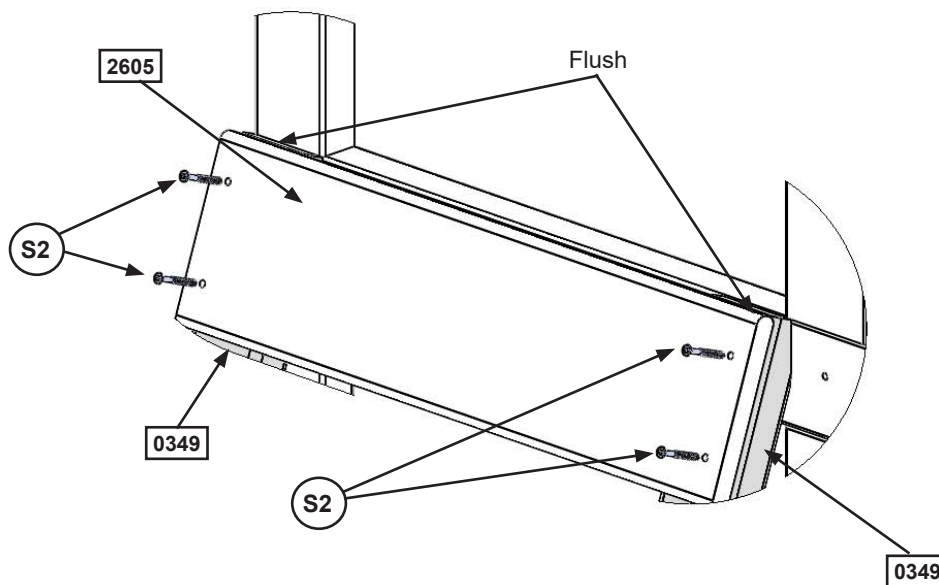


Fig. 15.3



### Wood Parts

1 x [2605] Access Board 1 x 6 x 19-3/4"

### Hardware

4 x (S2) #8 x 1-1/2" Wood Screw

4 x (S11) #8 x 2" Wood Screw

# Step 15: Attach Rock Wall Assembly to Fort

## Part 2

**C:** Drive 1 Rebar Ground Stake 13" into the ground against outside (0349) Rock Rail then attach with 1 (S7) #12 x 2" Pan Screw. Be careful not to hit the washer while hammering stake into the ground as this could cause the washer to break off. (fig. 15.4 and 15.5)

**D:** After driving stake into the ground, check for sharp edges caused by the impact of the hammer. Smooth any sharp edges from impact area and touch up with outdoor paint.

**⚠Warning!** To prevent tipping and avoid potential injury, stakes must be driven 13" into ground. Digging or driving stakes can be dangerous if you do not check first for under-ground wiring, cables or gas lines.

Fig. 15.4

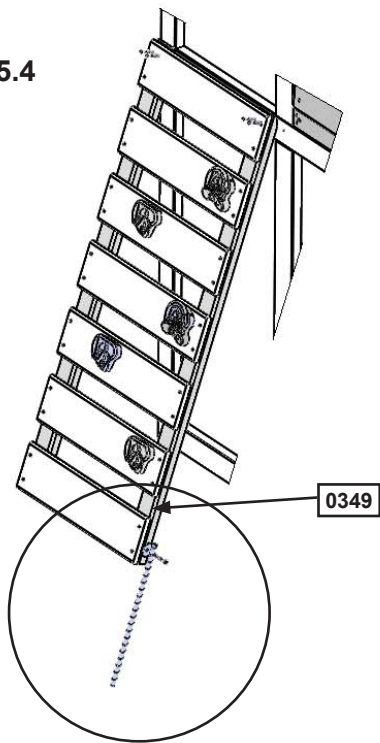
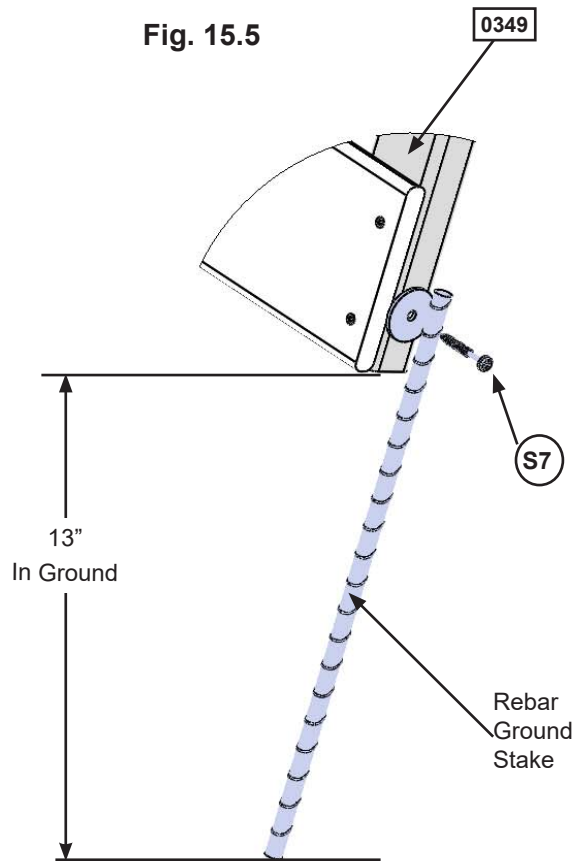


Fig. 15.5



### Hardware

1 x (S7) #12 x 2" Pan Screw

### Other Parts

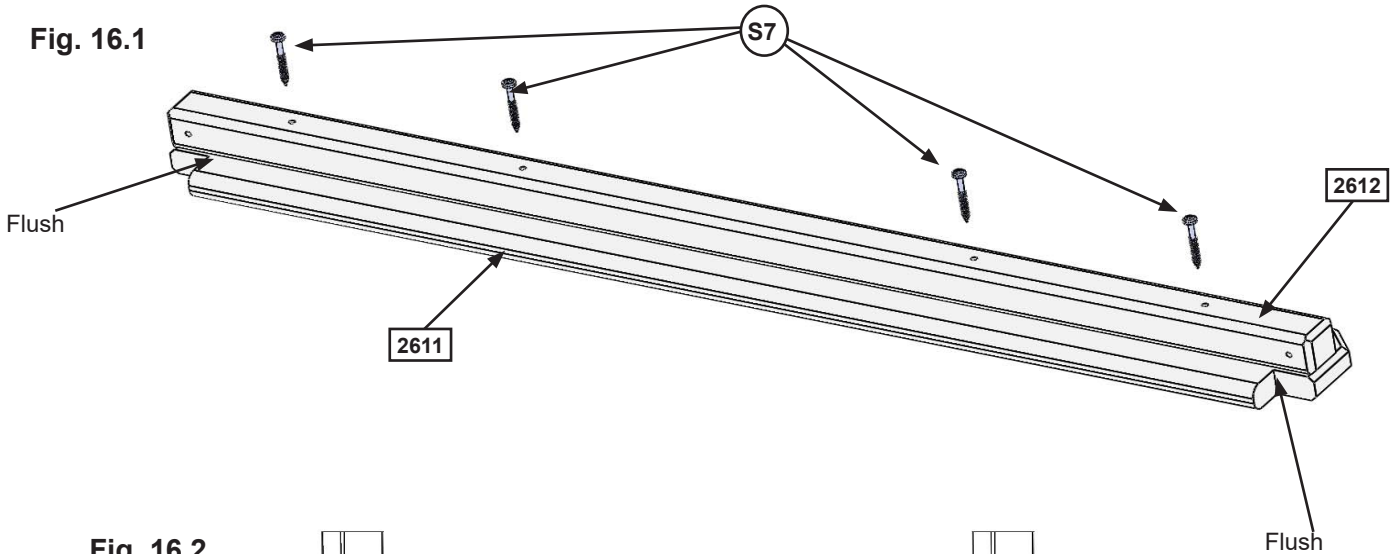
1 x Rebar Ground Stake

# Step 16: Cafe Table Assembly

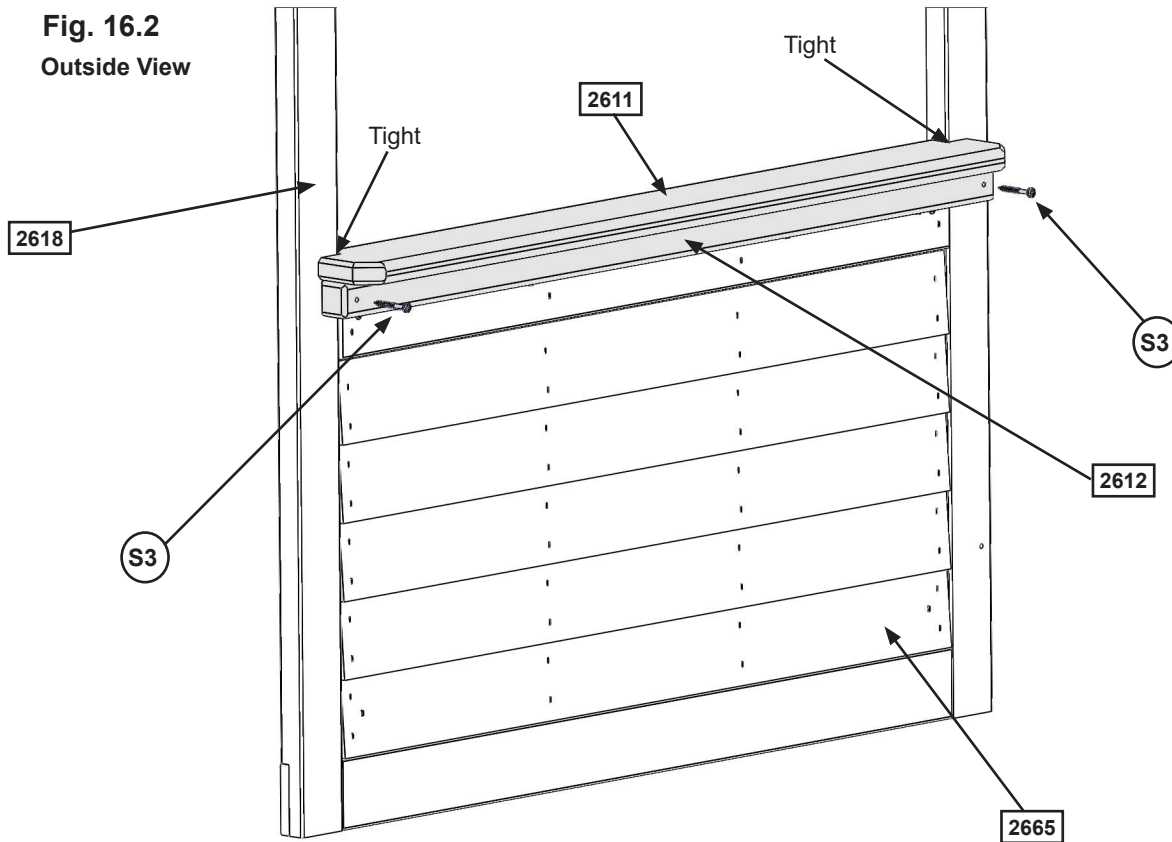
**A:** Place (2612) Table Support flush to the notched out ends of (2611) Table Top and attach with 4 (S7) #12 x 2" Pan Screws as shown in fig. 16.1.

**B:** Place Table Top Assembly tight in the opening of the back (2618) Front Back Panel on top of (2665) Half Wall Insert as shown in Fort Guide at the end of the instructions then attach (2612) Table Support to the panel with 2 (S3) #8 x 2-1/2" Wood Screws. (fig. 16.2)

**Fig. 16.1**



**Fig. 16.2**  
Outside View



### Wood Parts

- 1 x [2612] Table Support 2 x 2 x 39-5/8"
- 1 x [2611] Table Top 5/4 x 5 x 39-5/8"

### Hardware

- 4 x (S7) #12 x 2" Pan Screw
- 2 x (S3) #8 x 2-1/2" Wood Screw

# Step 17: Attach Cafe Canopy to Fort



**A:** Feed Cafe Canopy Frame through the pocket of the Cafe Canopy. (fig. 17.1)

**B:** With a helper hold the Canopy against the fort, centred on the (2618) Front Back Panel shown on the Fort Guide, make sure the Cafe Canopy is smooth and tight then attach to the panel with 1 (S5) #8 x 1/2" Pan Screw (with #8 flat washer), measure 1-1/2" down from the first screw then attach a second screw and washer. Follow measurements as shown in fig. 17.2 for remaining screws and washers. Measurements must be exact.

**C:** Hold the Cafe Canopy Frame against the panel and attach with 1 (S6) #12 x 1" Pan Screw per side. (fig. 17.2)

Fig. 17.1

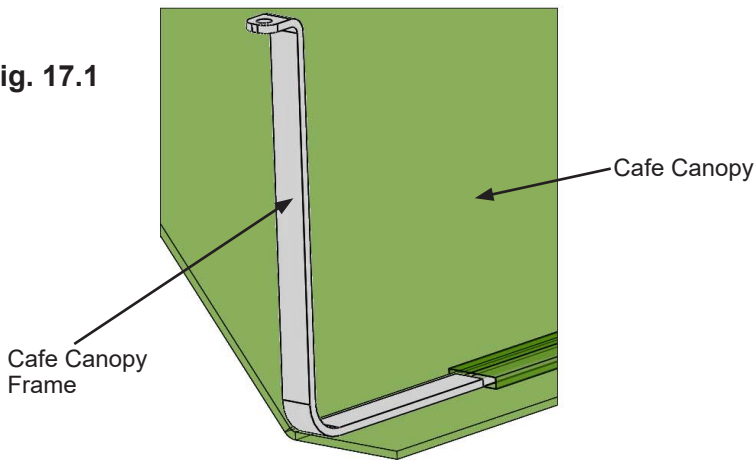
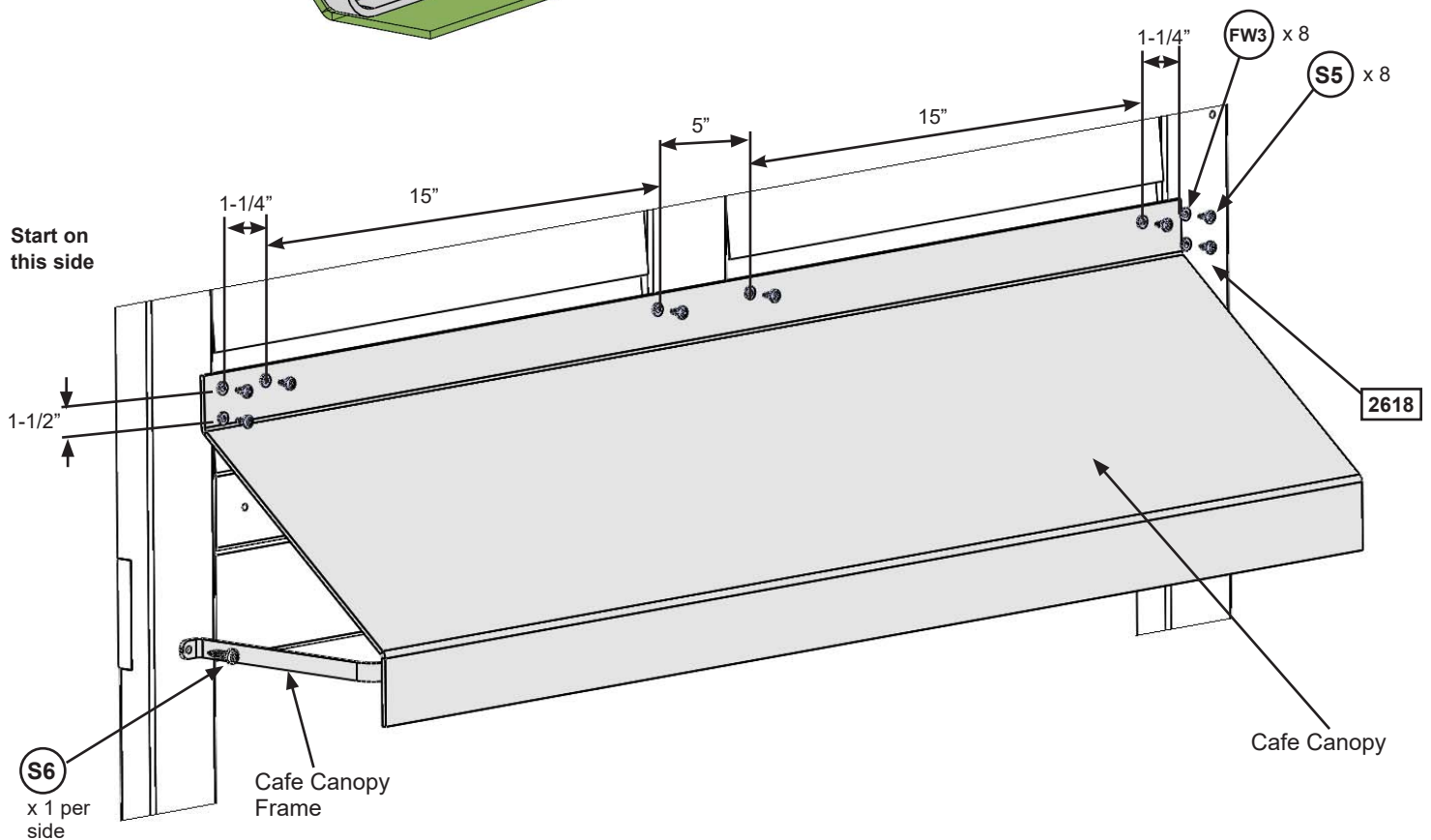


Fig. 17.2



**Hardware**

- 8 x (S5) #8 x 1/2" Pan Screw (FW3)
- 2 x (S6) #12 x 1" Pan Screw

**Other Parts**

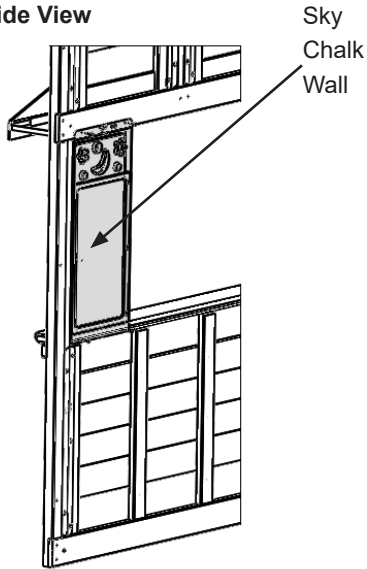
- 1 x Cafe Canopy Frame
- 1 x Cafe Canopy

# Step 18: Attach Sky Chalk Wall to Fort

**A:** From inside the assembly place Sky Chalk Wall tight to (2611) Table Top and (2618) Front Back Panel then attach with 4 (S10) #8 x 1" Pan Screws from the inside and 1 (S10) #8 x 1" Pan Screw from the outside. (fig. 18.1, 18.2, 18.3 and 18.4)

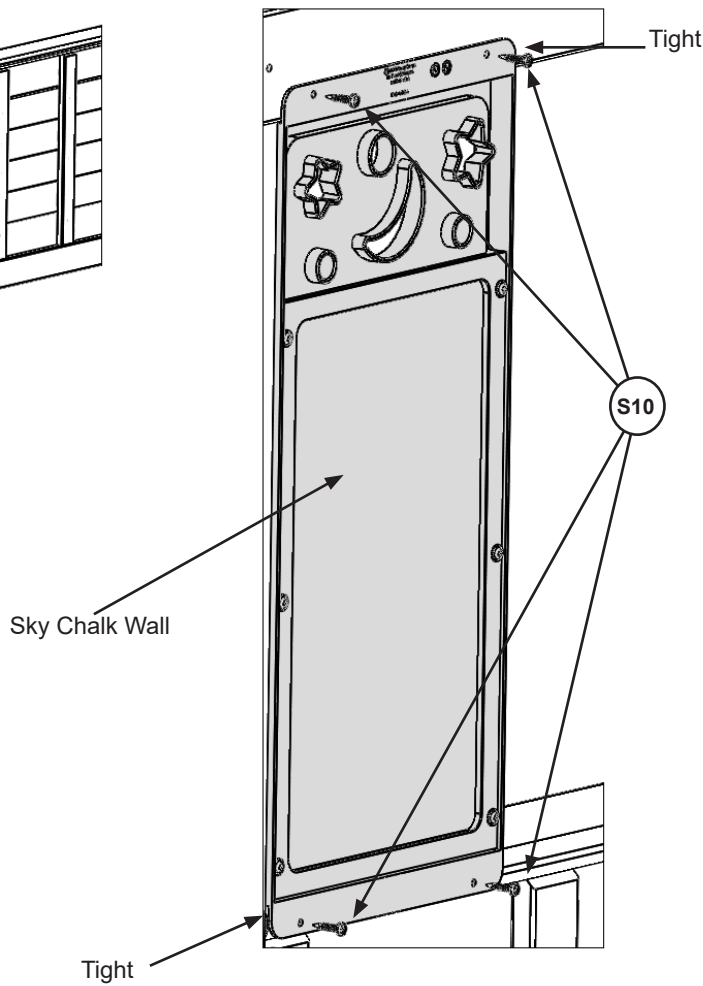
**Fig. 18.1**

Inside View



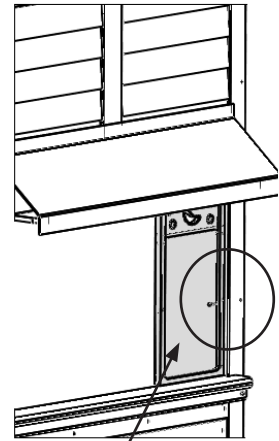
**Fig. 18.2**

Inside View



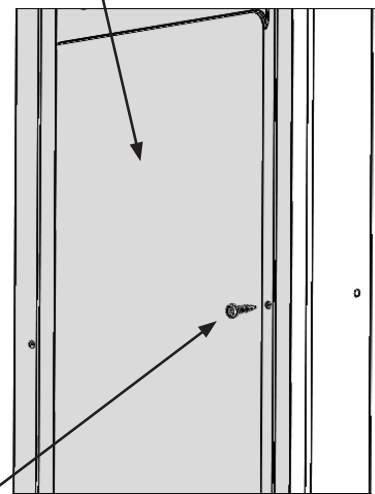
**Fig. 18.3**

Outside View



Sky Chalk Wall

**Fig. 18.4**  
Outside View



**Hardware**

5 x (S10) #8 x 1" Pan Screw

**Other Parts**

1 x Sky Chalk Wall



# Step 19: Attach Slides to Fort



**A:** At the front of the fort place each Slide in the centre of each opening of (2618) Front Back Panel, pre-drill with a 1/8" drill bit then attach both slides to fort through the panel using 3 (S7) #12 x 2" Pan Screws per slide. (fig. 19.1, 19.2 and 19.3)

Fig. 19.1

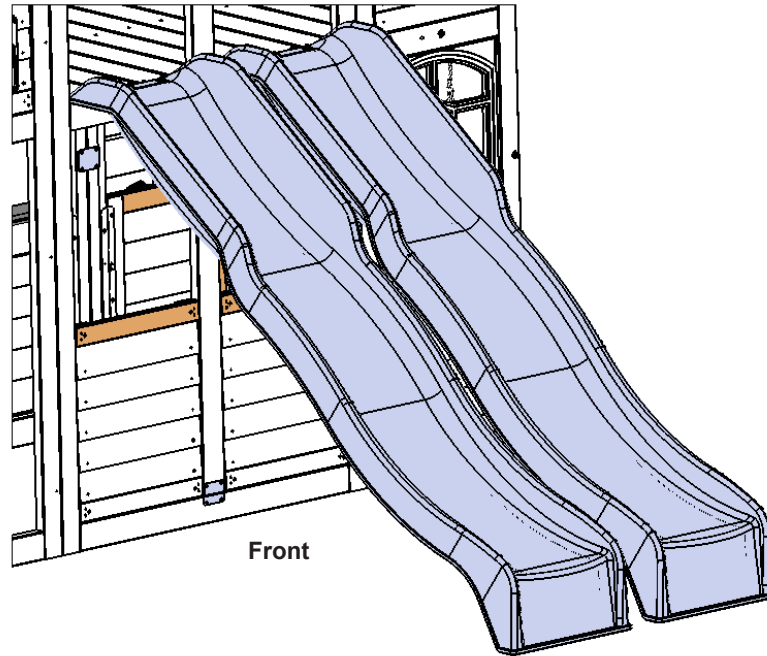


Fig. 19.2

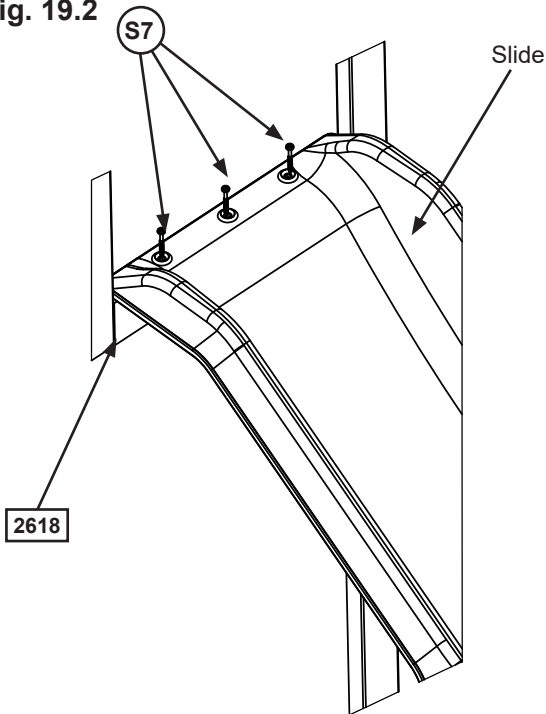
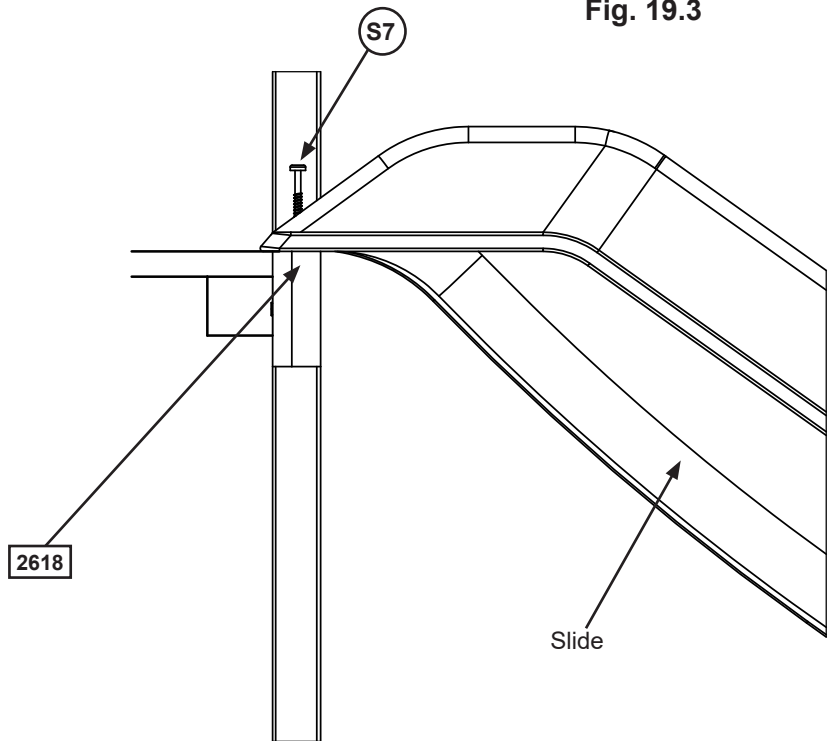


Fig. 19.3



### Hardware

6 x (S7) #12 x 2" Pan Screw

### Other Parts

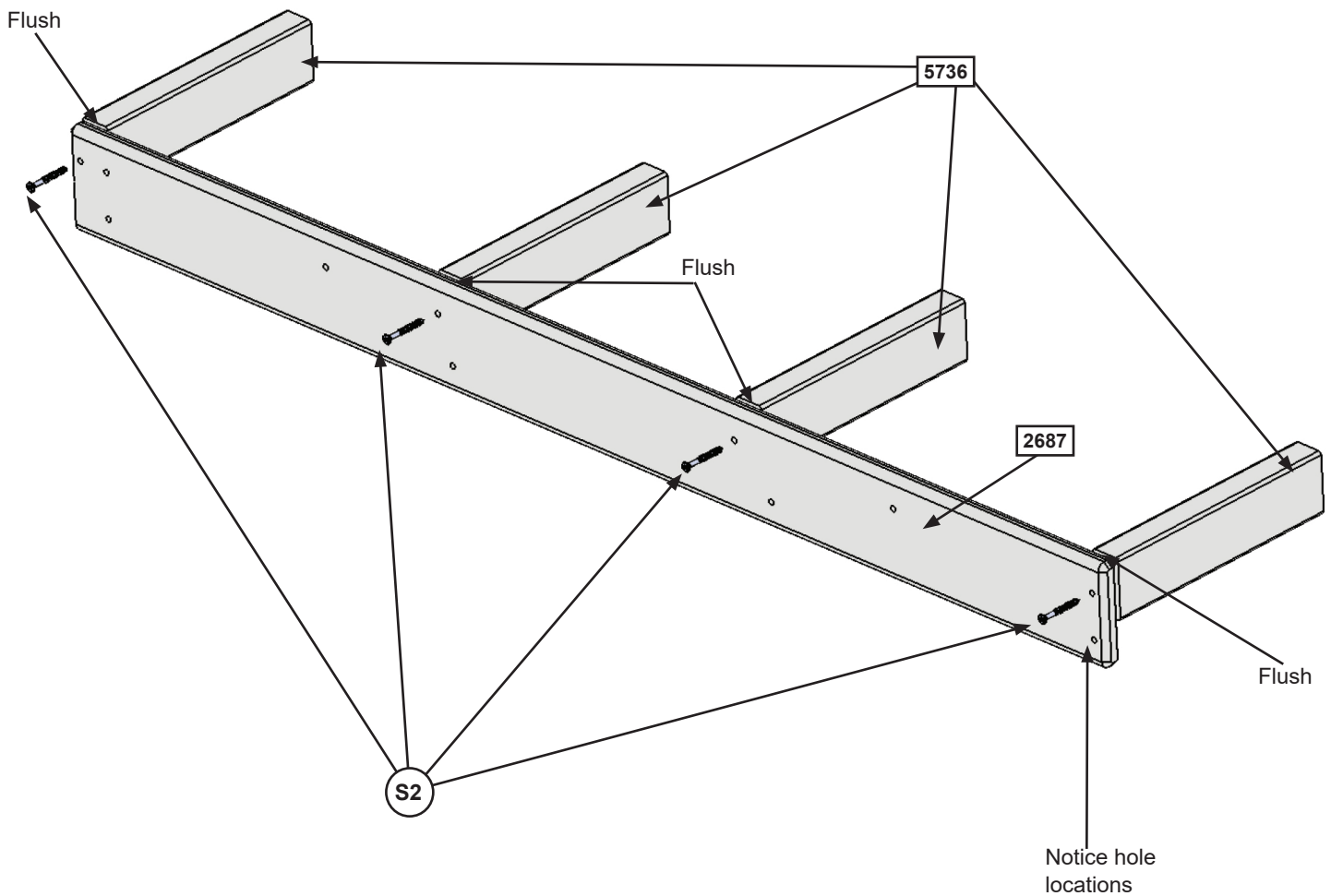
2 x Slide

# Step 20: Counter Assembly Part 1

**A:** Flush to each end and to the top of (2687) Counter Back attach 1 (5736) Counter Joist per end with 1 (S2) #8 x 1-1/2" Wood Screw per joist. Notice the remaining holes at the bottom of (2687) Counter Back. (fig. 20.1)

**B:** Place the remaining 2 (5736) Counter Joists centred over the pilot holes in the middle of (2687) Counter Back and flush to the top of the board, then attach, in the top holes, with 1 (S2) #8 x 1-1/2" Wood Screw per joist. (fig. 20.1)

Fig. 20.1



### Wood Parts

- 1 x 2687 Counter Back 1 x 4 x 40-5/8"
- 4 x 5736 Counter Joist 1 x 2 x 8-1/4"

### Hardware

- 4 x S2 #8 x 1-1/2" Wood Screw

# Step 20: Counter Assembly Part 2

C: On the inside of (2627) SW Wall Panel place Counter Assembly so the top of (2687) Counter Back is flush to the top of the opening then attach with 5 (S2) #8 x 1-1/2" Wood Screws. (fig. 20.2 and 20.3)

Fig. 20.2  
Outside View

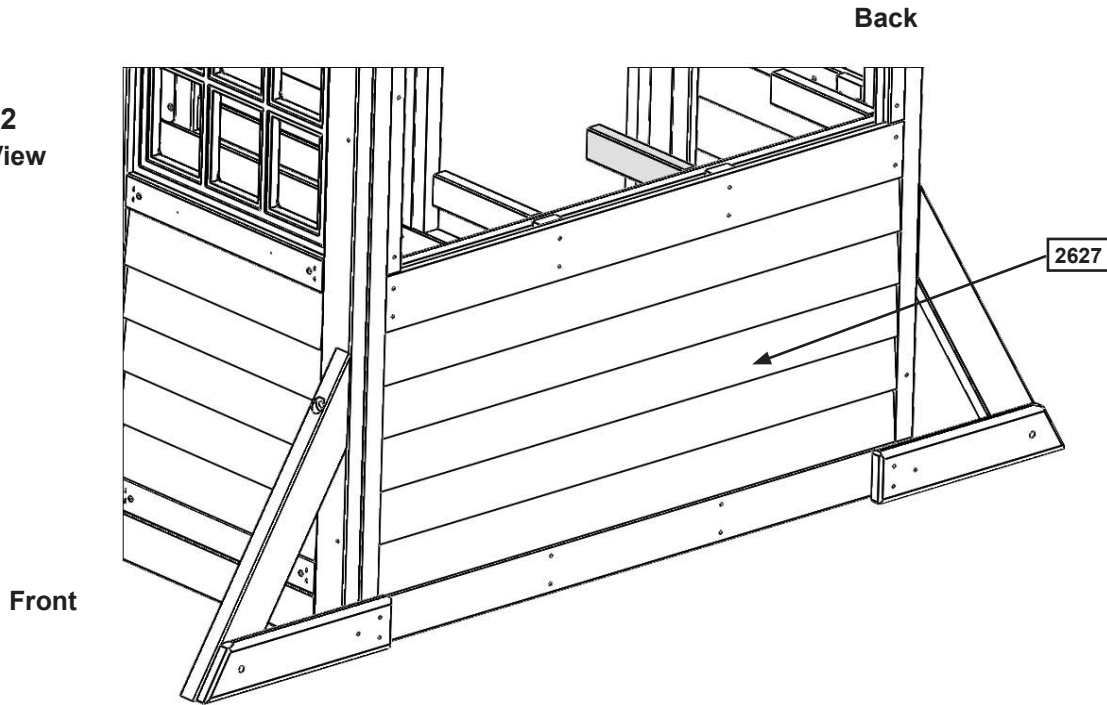
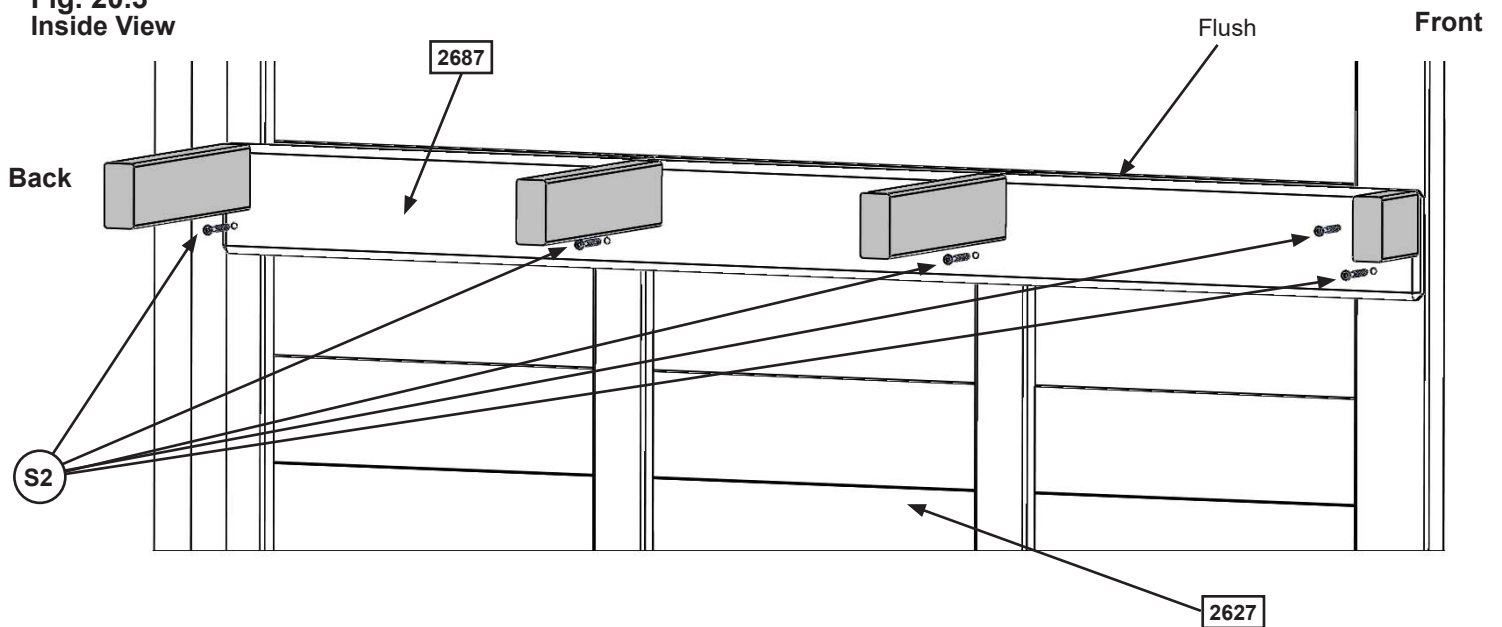


Fig. 20.3  
Inside View



## Hardware

5 x (S2) #8 x 1-1/2" Wood Screw

# Step 20: Counter Assembly Part 3

D: Place 1 (6136) Counter Brace flush to the front and outside edge of each outer (5736) Counter Joist and tight to (2627) SW Wall Panel then attach with 2 (S3) #8 x 2-1/2" Wood Screws per brace. (fig. 20.4 and 20.5)

Fig. 20.4

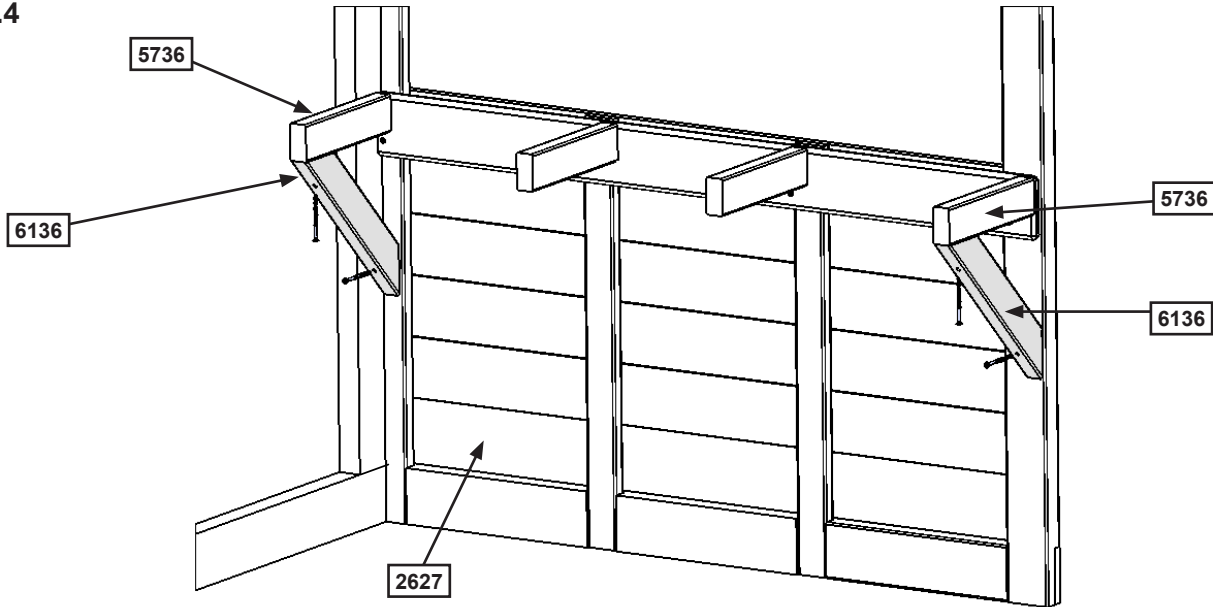
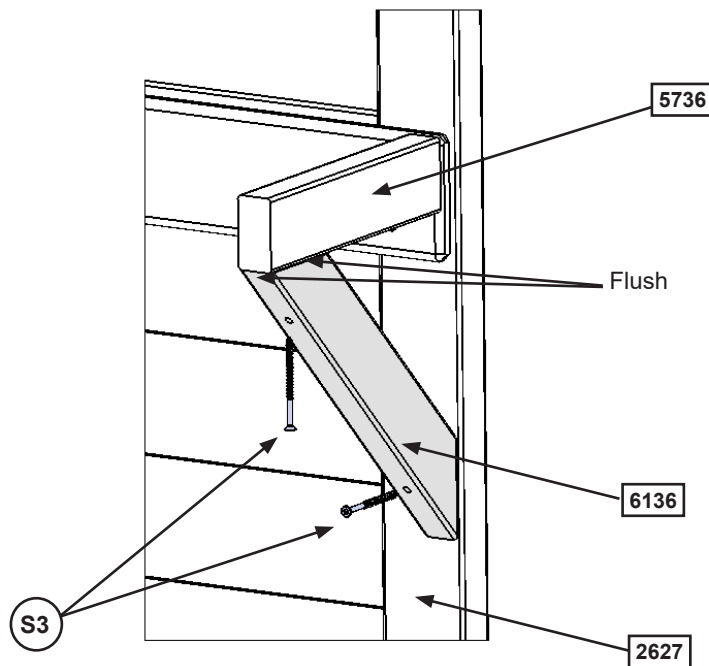


Fig. 20.5



### Wood Parts

2 x 6136 Counter Brace 1 x 2 x 12-9/16"

### Hardware

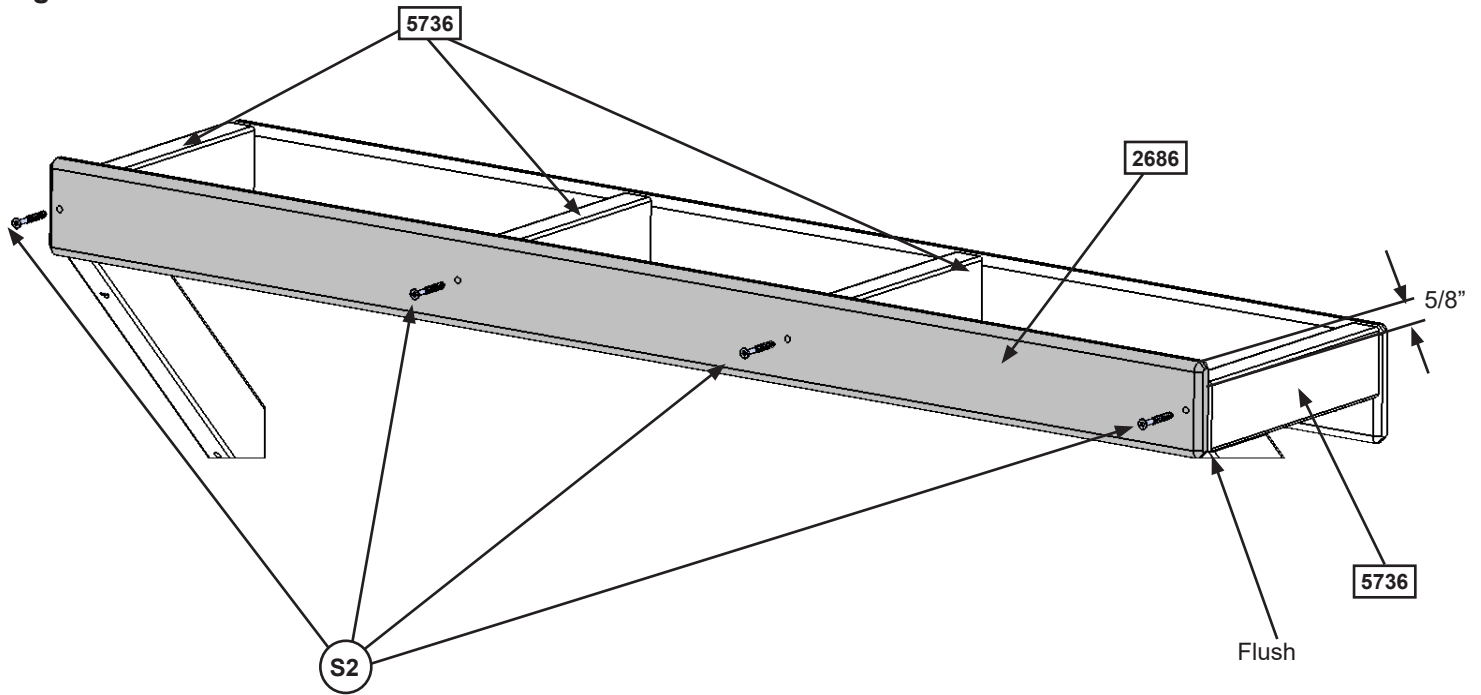
4 x S3 #8 x 2-1/2" Wood Screw

# Step 20: Counter Assembly Part 4



**E:** Place (2686) Counter Front against (5736) Counter Joists so the ends are flush and the centre (5736) Counter Joists are centred over the pilot holes. Measure 5/8" down from the top of (2686) Counter Front on both ends and attach to the (5736) Counter Joists with 4 (S2) #8 X 1-1/2" Wood Screws. (fig. 20.6)

Fig. 20.6



### Wood Parts

1 x **2686** Counter Front 5/8 x 2-3/4 x 40-5/8"

### Hardware

4 x **S2** #8 x 1-1/2" Wood Screw

# Step 20: Counter Assembly

## Part 5

**F:** Tight to (2687) Counter Back attach (2685) Counter Top to each (5736) Counter Joist with 4 (TS) #6 x 30 mm Trim Screws. (fig. 20.7)

**G:** Tight to (2685) Counter Top and flush to the outside edges of the outer (5736) Counter Joists attach 1 (5536) Counter Side per joist with 3 (TS) #6 x 30 mm Trim Screws per board. (fig. 20.7)

**H:** Tight to (2685) Counter Top and centred over the middle 2 (5736) Counter Joists with ends flush to the outside edges attach 2 (2716) Counter Mid Tops with 4 (TS) #6 x 30 mm Trim Screws per board. (fig. 20.7)

**I:** Attach (2685) Counter Top to (2627) SW Wall Panel with 2 (TS) #6 x 30 mm Trim Screws per board. (fig. 20.8)

Fig. 20.7

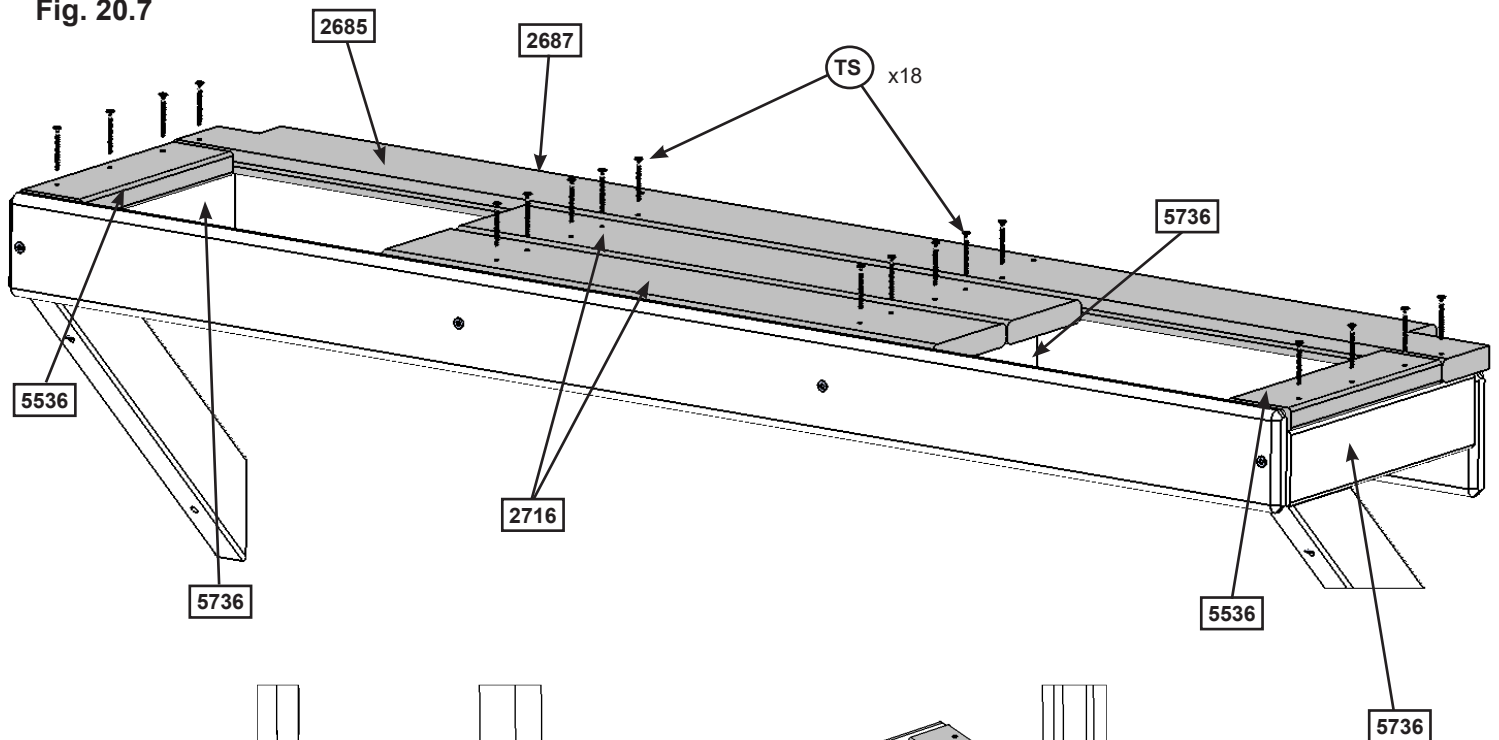
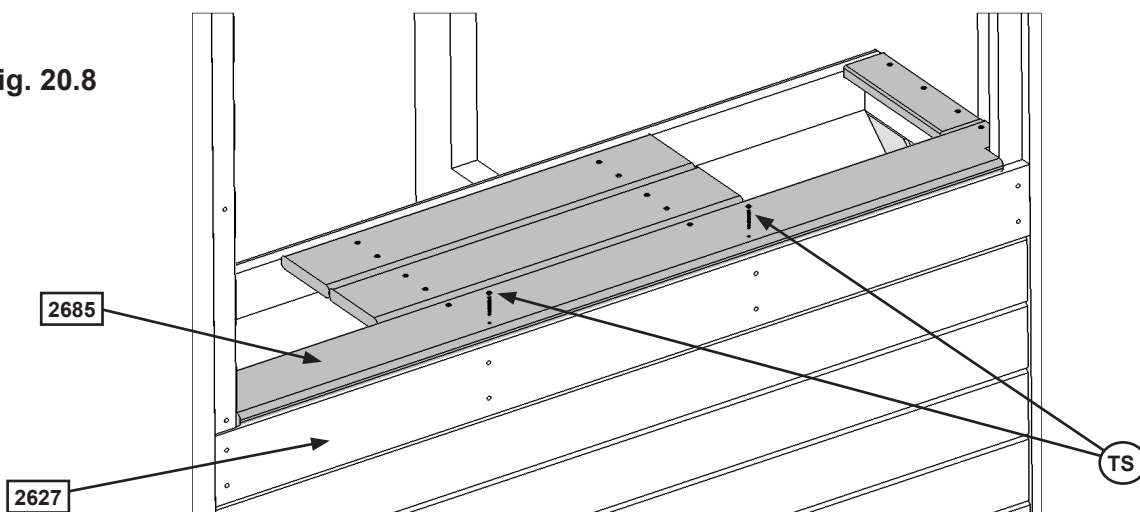


Fig. 20.8



### Wood Parts

- 2 x 2716 Counter Mid Top 1 x 4 x 17-5/8"
- 1 x 2685 Counter Top 1 x 4 x 40-5/8"
- 2 x 5536 Counter Side 5/8 x 2 x 6-3/4"

### Hardware

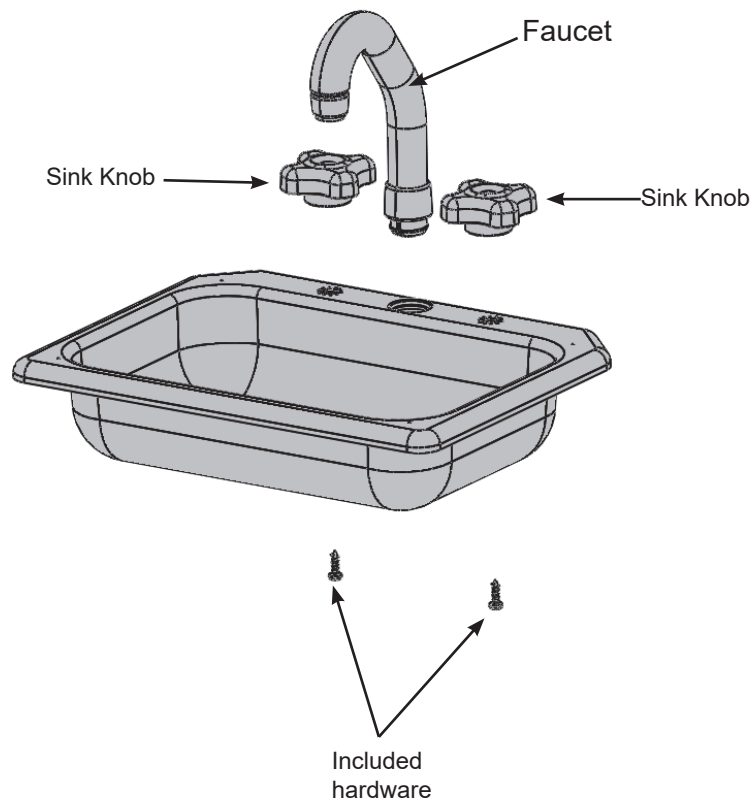
- 20 x TS #6 x 30 mm Trim Screw

## Step 20: Counter Assembly Part 6

J: Place Faucet and 2 Sink Knobs in opening of Sink and attach Sink Knobs with included hardware. (fig. 20.9)

**Important: Use a hand held screw driver and DO NOT over tighten.**

Fig. 20.9



**Other Parts**

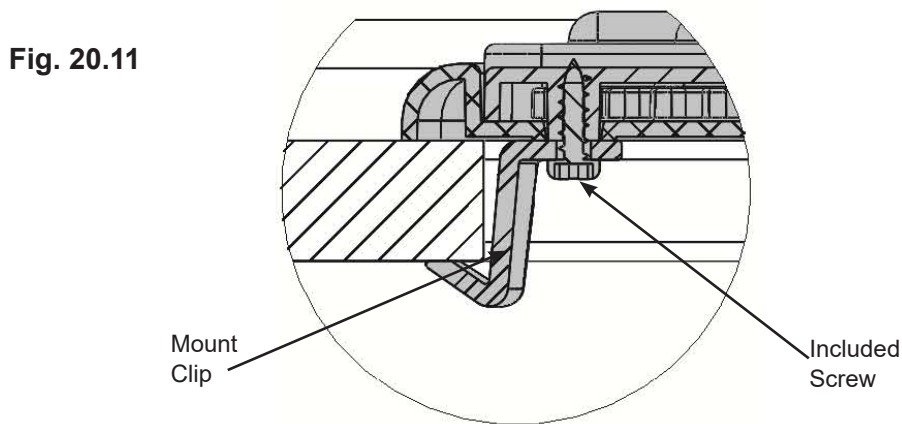
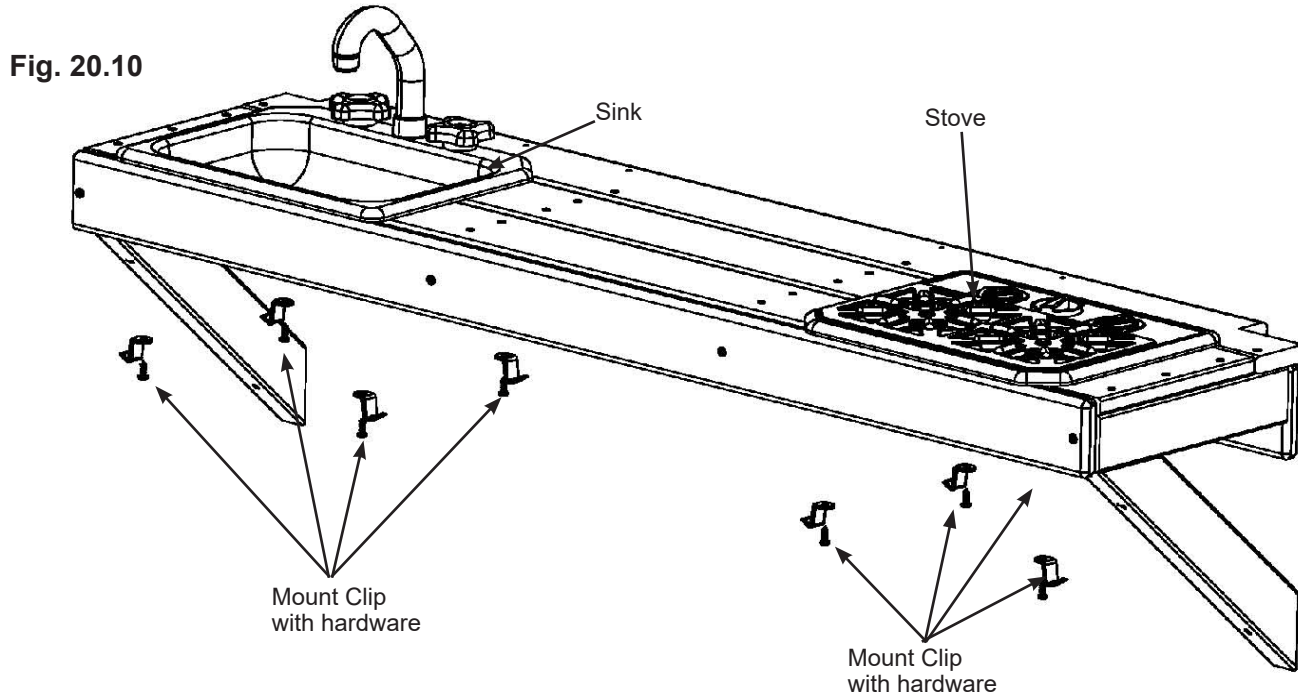
1 x 3320969

# Step 20: Counter Assembly Part 7

**K:** Place Sink and Stove in the openings of the Counter Assembly then attach 4 Mount Clips with included hardware to the bottom of the Sink and Stove to secure in place. (fig. 20.10 and 20.11)

**Important:** Use a hand held screw driver and **DO NOT** over tighten.

Note: To remove the Sink or Stove loosen screw 1/4 turn then twist Mount Clips.



### Other Parts

1 x 3320969  
8 x Mount Clip



# Step 21: Attach Utensil Shelf

**A:** From inside the assembly, centred in the top of the opening of (2627) SW Wall Panel above the counter attach Utensil Shelf with 2 (S5) #8 x 1/2" Pan Screws as shown in fig. 21.1 and 21.2.

**B:** Attach Pot, Pan and Spatula to the Utensil Shelf. (fig. 21.2 and 21.3)

Fig. 21.1

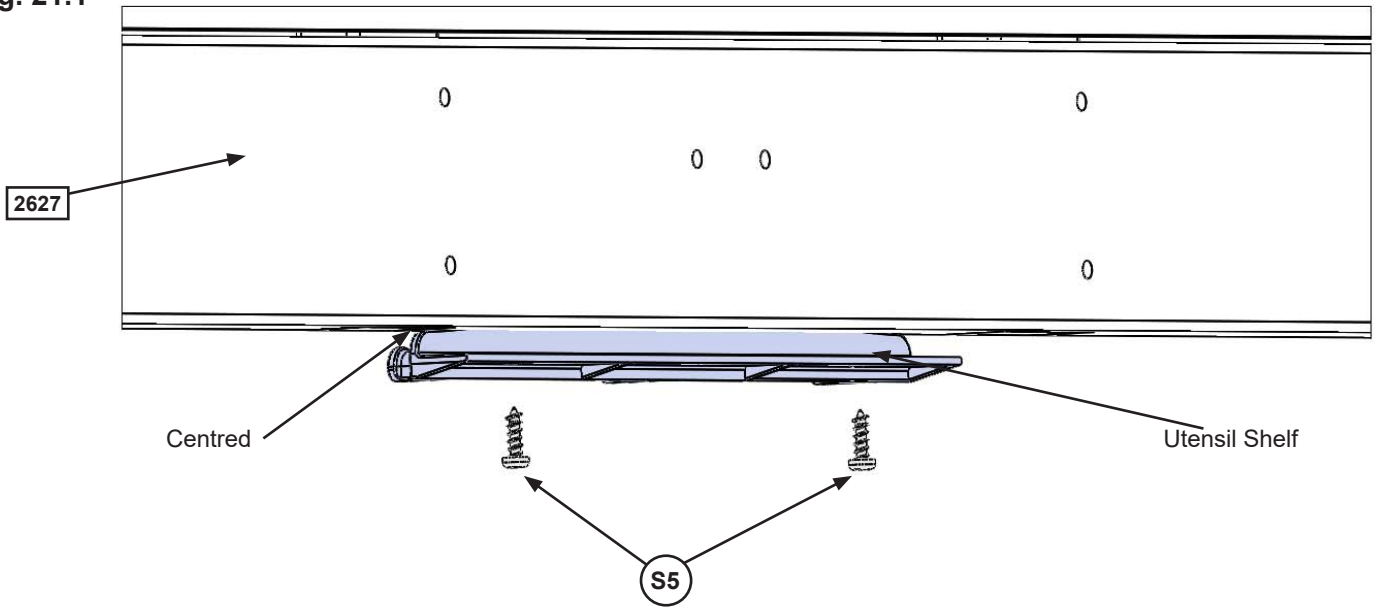


Fig. 21.2

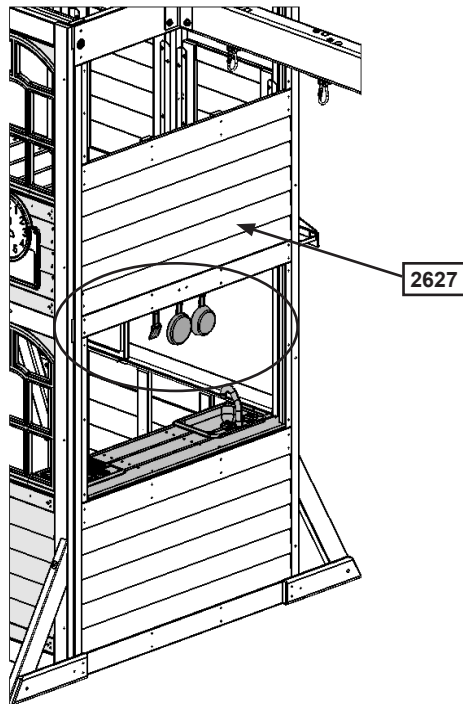
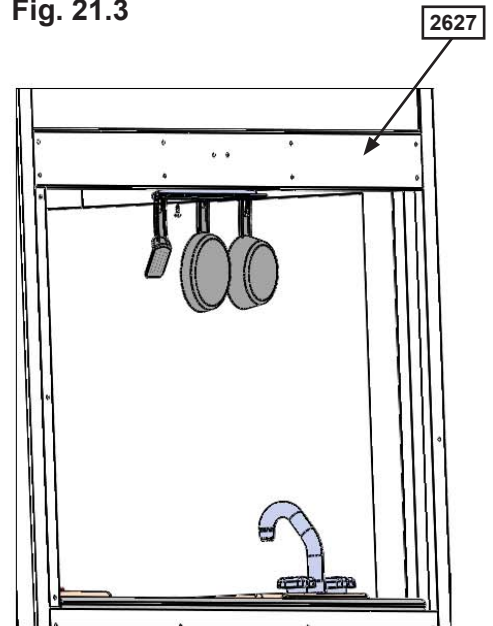


Fig. 21.3



## Hardware

2 x (S5) #8 x 1/2" Pan Screw

## Other Parts

1 x Utensil Shelf  
1 x 9320889 (Pot Pan Spatula)

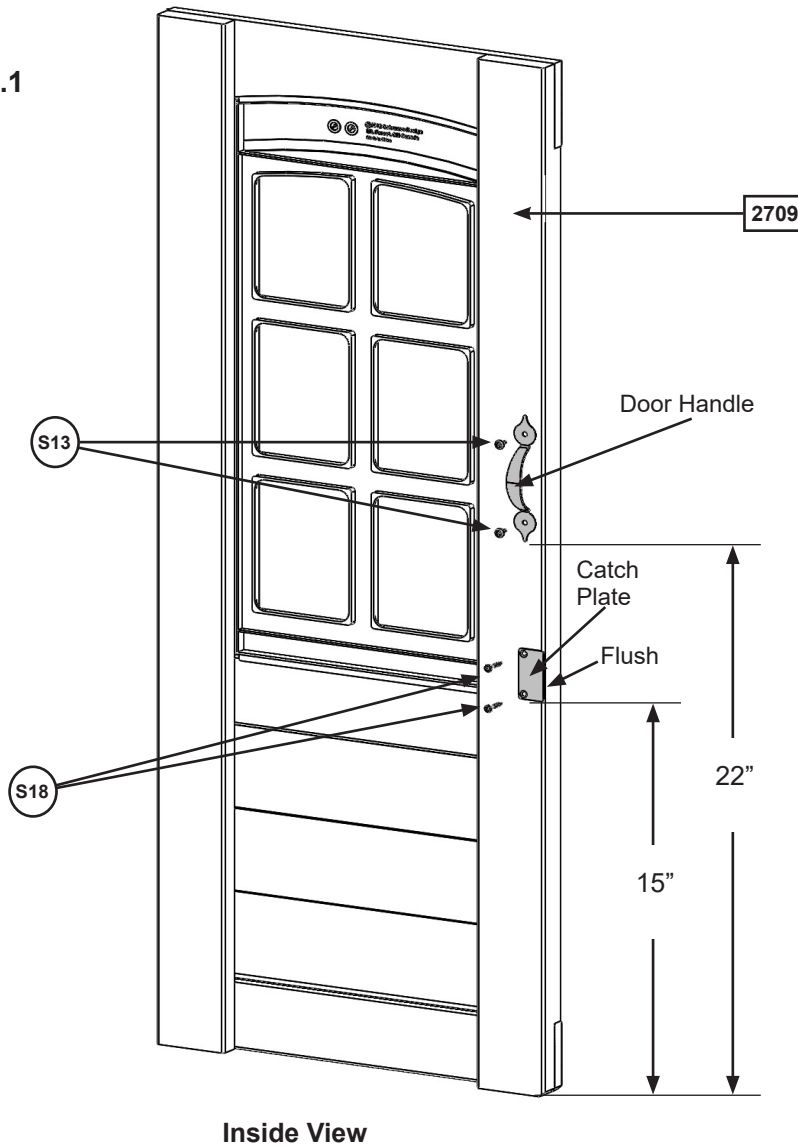
# Step 22: Attach Door Components Part 1



**A:** On the inside of (2709) Door Window Panel measure 15" up from the bottom and attach Catch Plate flush to the edge using 2 (S18) #6 x 1" Wood Screws. (fig. 22.1)

**B:** On the inside of (2709) Door Window Panel measure 22" up from the bottom and attach 1 Door Handle using 2 (S13) #6 x 5/8" Pan Screws. (fig. 22.1)

Fig. 22.1



Inside View

### Wood Parts

1 x 2709 Door Window Panel 1-1/4 x 15-3/4 x 40-3/4"

### Hardware

2 x S18 #6 x 1" Wood Screw

2 x S13 #6 x 5/8" Pan Screw

### Other Parts

1 x Door Handle

1 x Catch Plate

# Step 22: Attach Door Components Part 2



**C:** On the outside of the (2709) Door Window Panel attach the second Door Handle at approximately the same place as the one on the inside. Use 2 (S13) #6 x 5/8" Pan Screws. (fig. 22.2)

**D:** On the opposite side of the Door Handle measure 5/8" from the top and bottom of (2709) Door Window Panel attach 2 Door Hinges on the outside using 3 (S13) #6 x 5/8" Pan Screws per Hinge. (fig. 22.2 and 22.4)

**Note:** Hinge stops must be tight to (2709) Door Window Panel. (fig. 22.3)

Fig. 22.2

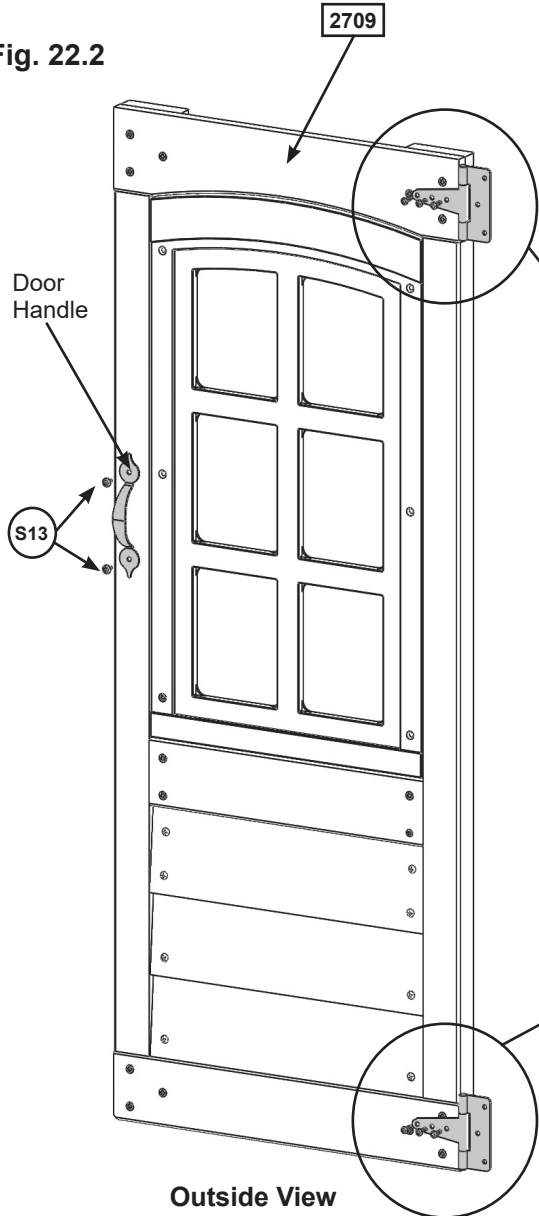


Fig. 22.3  
Top View

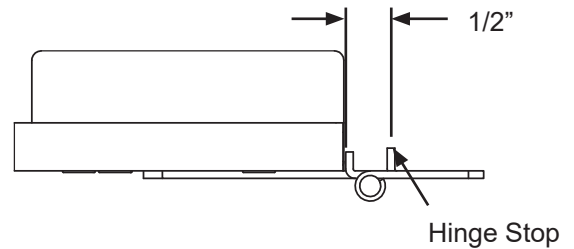
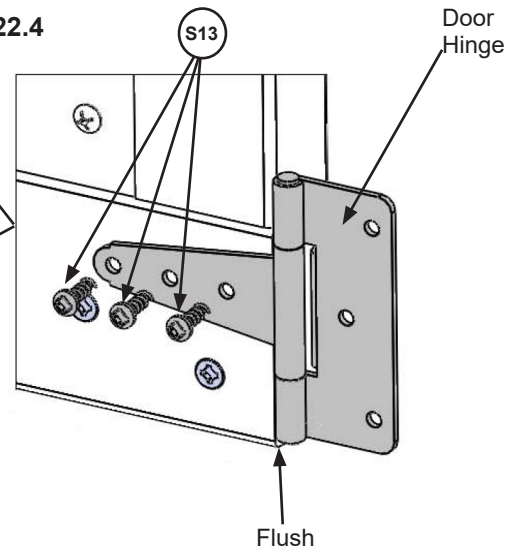


Fig. 22.4



### Hardware

8 x (S13) #6 x 5/8" Pan Screw

### Other Parts

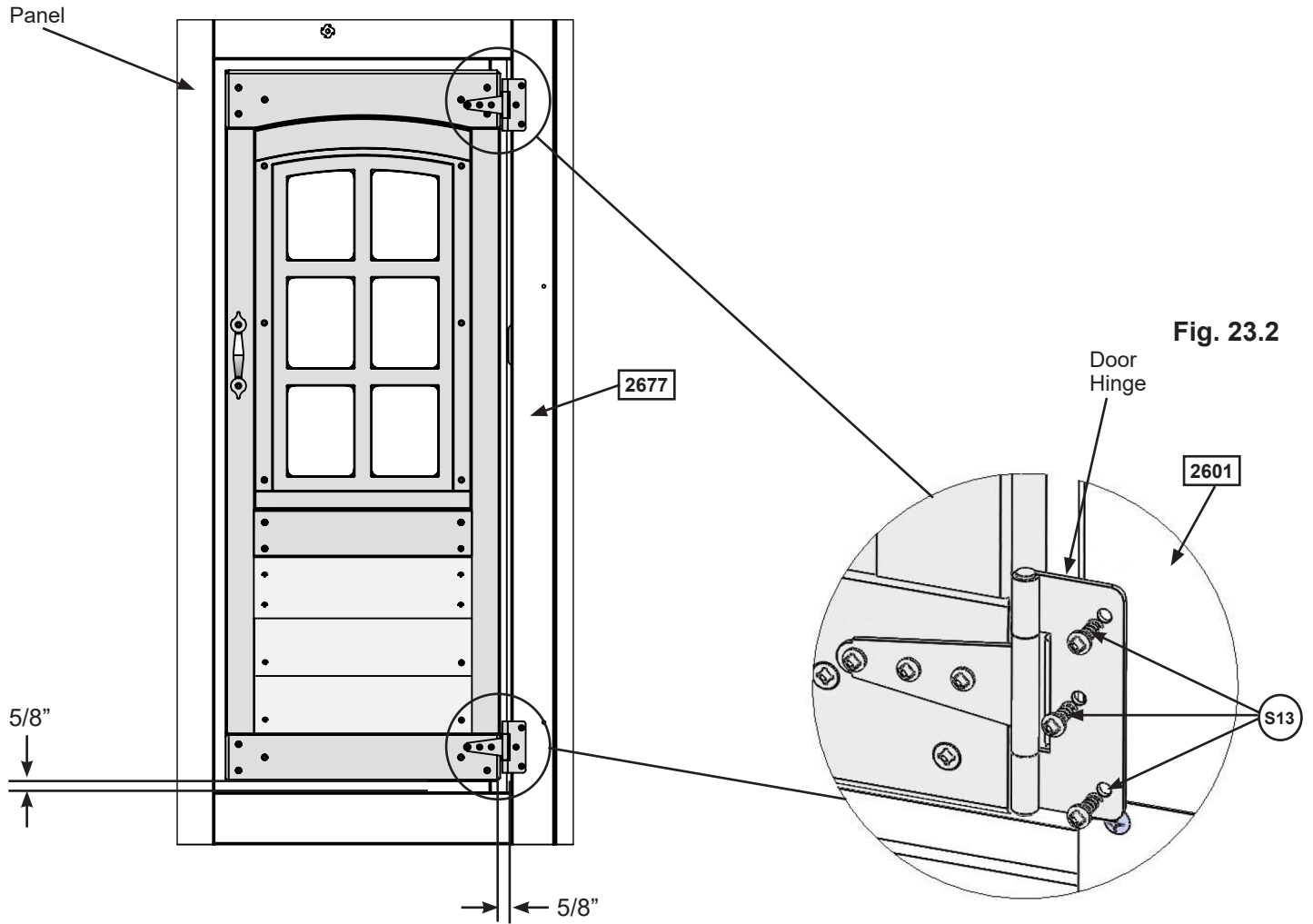
1 x Door Handle  
2 x Door Hinge

# Step 23: Attach Door Assembly to Fort



**A:** In the opening for the door on the Front Wall, measure 5/8" up from the bottom of the opening and maximum 5/8" from (2677) Narrow Panel and attach the remaining side of the hinges to (2677) Narrow Panel using 3 (S13) #6 x 5/8" Pan Screws per hinge. (fig. 23.1 and 23.2)

**Fig. 23.1**  
Outside View



### Hardware

6 x (S13) #6 x 5/8" Pan Screw

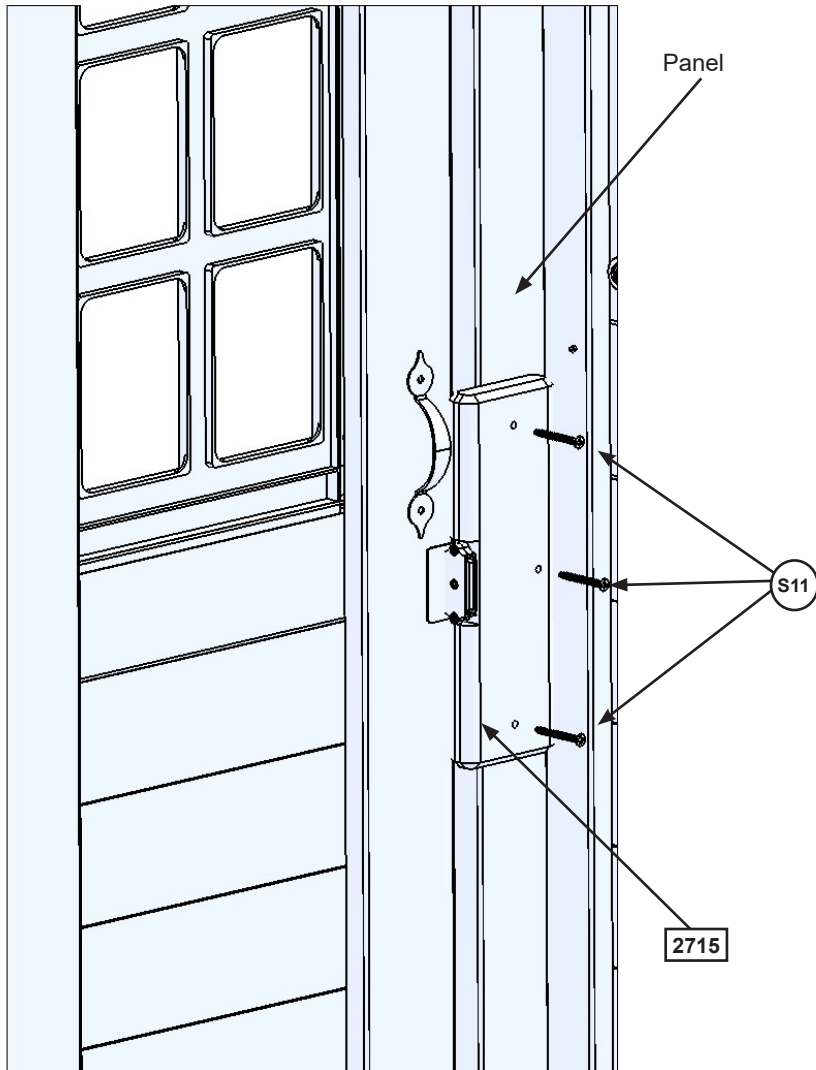
# Step 24: Attach Door Stop



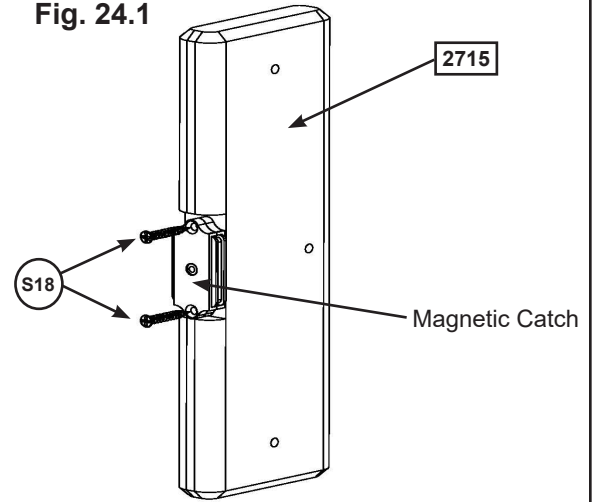
**A:** In the notched out opening of (2715) Door Stop attach the Magnetic Catch using 2 (S18) #6 x 1" Wood Screws. (fig. 24.1) **Important: Use a hand held screw driver and DO NOT over tighten.**

**B:** On the inside of the assembly, attach (2715) Door Stop to the panel with 3 (S11) #8 x 2" Wood Screws, making sure (2715) Door Stop overhangs the panel by 1-1/4" and is in position to receive the Catch Plate. (fig. 24.2 and 24.3).

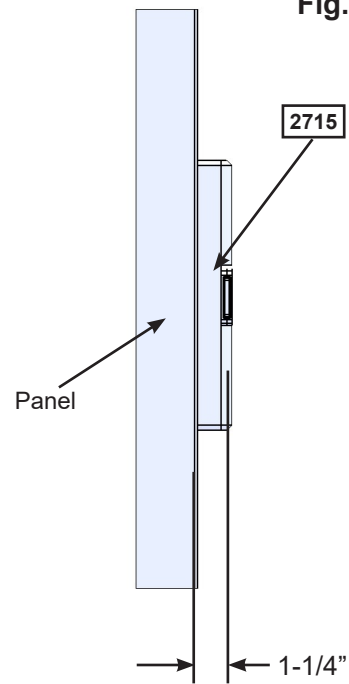
**Fig. 24.2**  
Inside View



**Fig. 24.1**



**Fig. 24.3**



**Wood Parts**

1 x 2715 Door Stop 5/4 x 3 x 10"

**Hardware**

2 x S18 #6 x 1" Wood Screw

3 x S11 #8 x 2" Wood Screw

**Other Parts**

1 x Magnetic Catch

## Step 25: Roof Support Assemblies

**A:** Attach 1 (2617) Roof Support to a second (2617) Roof Support at peak using 1 (S4) #8 x 3" Wood Screw. Repeat this step so there are 2 Roof Support Assemblies. (fig. 25.1)

**B:** Attach 1 (2680) Roof Support to a second (2680) Roof Support at peak using 1 (S4) #8 x 3" Wood Screw. Repeat this step so there are 2 Small Roof Support Assemblies. (fig. 25.2)

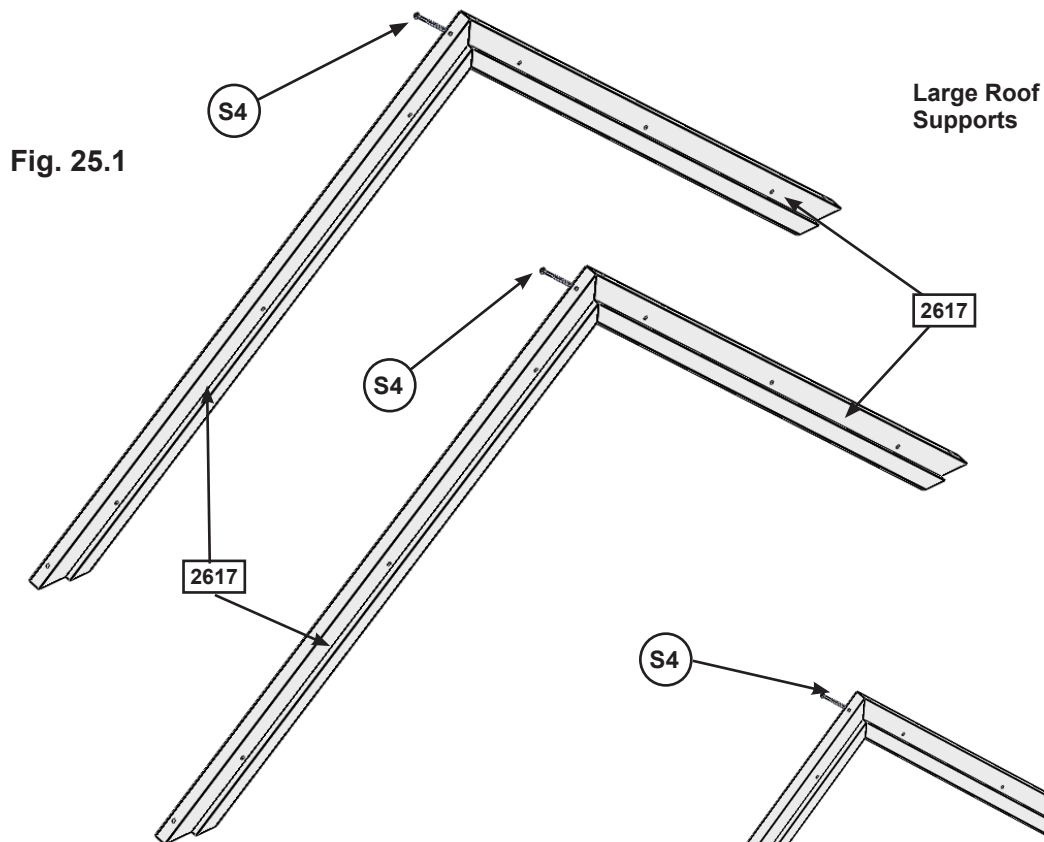
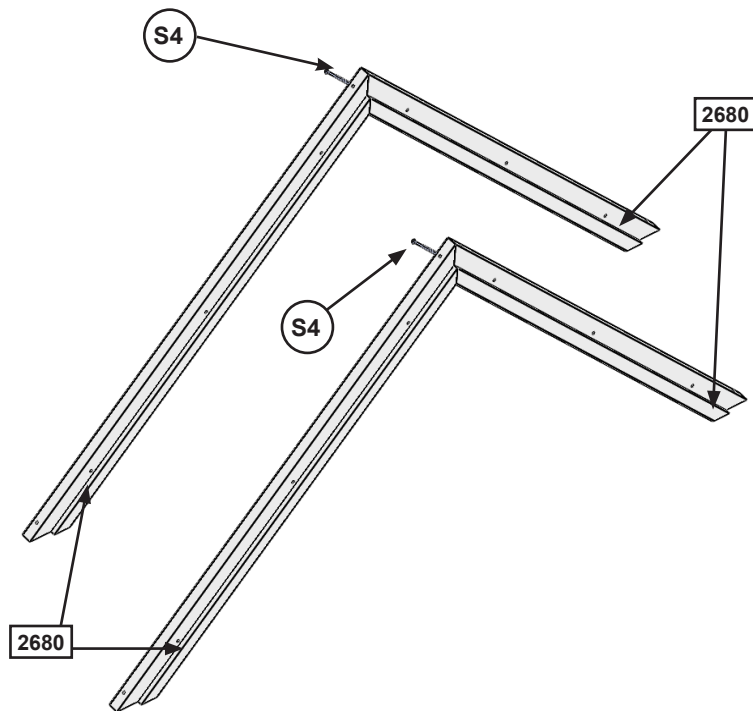


Fig. 25.2



### Wood Parts

- 4 x Roof Support 1-1/4 x 2-1/4 x 37-1/2"
- 4 x Roof Support 1-1/4 x 2-1/4 x 34-1/16"

### Hardware

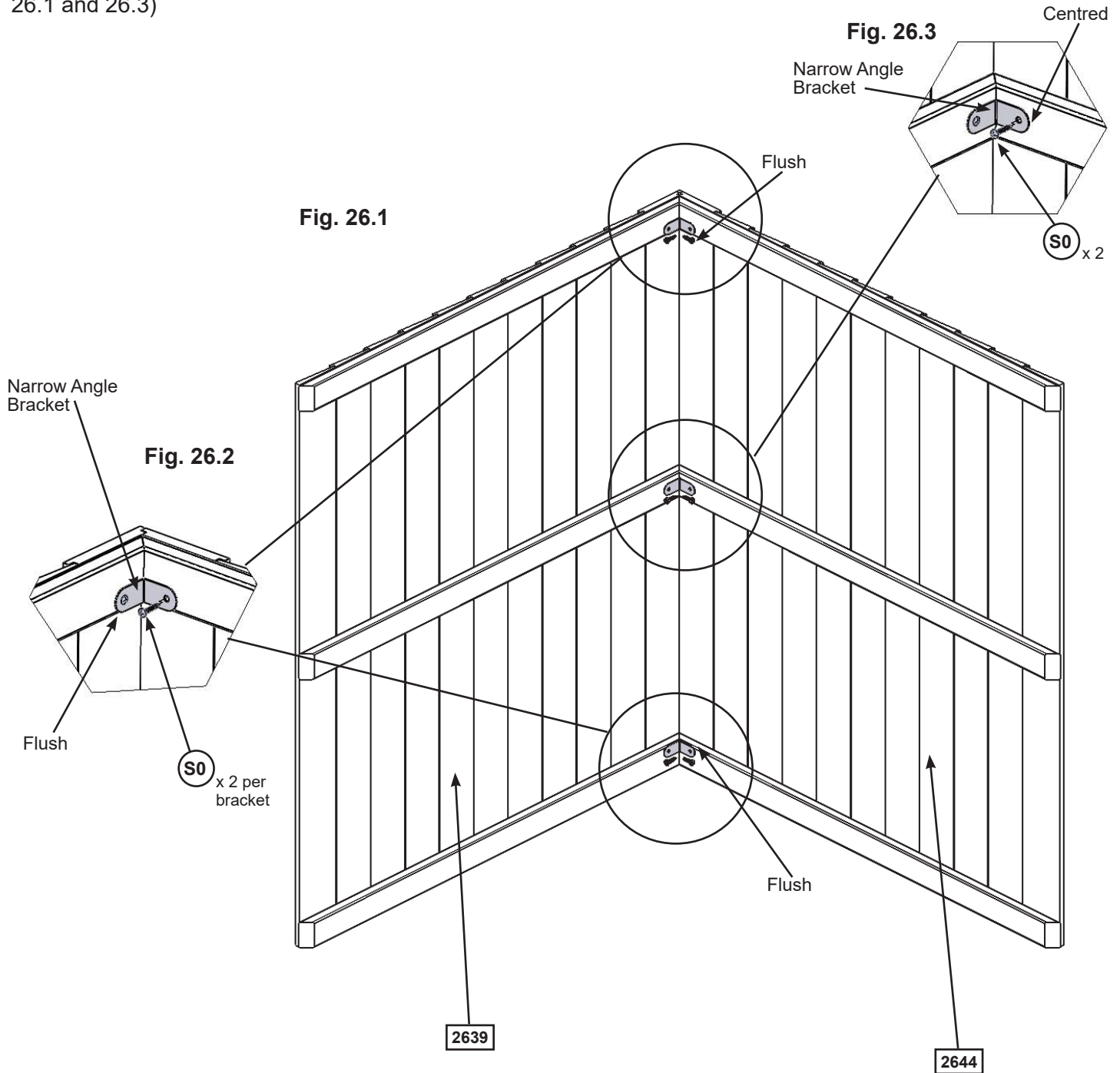
- 4 x #8 x 3" Wood Screw

# Step 26: Large Roof Assembly Part 1



**A:** Place (2644) Front Roof Panel against (2639) Back Roof Panel so the tops form a peak then tight to the inside edge of the outside slats attach 1 Narrow Angle Bracket per slat with 2 (S0) #8 x 7/8" Truss Screws per bracket. (fig. 26.1 and 26.2)

**B:** Attach the third Narrow Angle Bracket centred on the middle slat with 2 (S0) #8 x 7/8" Truss Screws. (fig. 26.1 and 26.3)



### Wood Parts

- 1 x 2644 Front Roof Panel 1-1/4 x 37 x 44"
- 1 x 2639 Back Roof Panel 1-1/4 x 36-3/4 x 44"

### Hardware

- 6 x S0 #8 x 7/8" Truss Screw

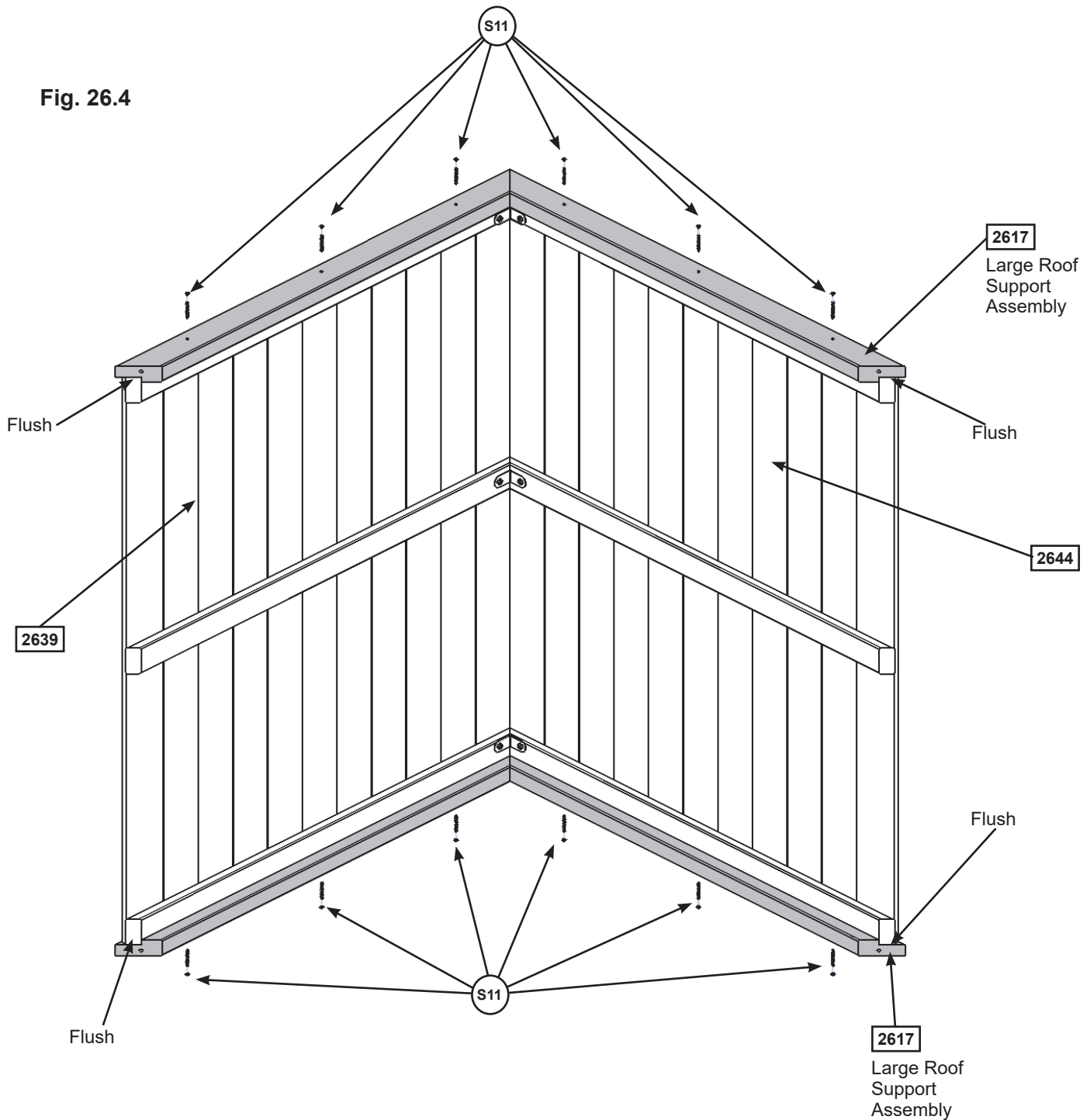
### Other Parts

- 3 x Narrow Angle Bracket


## Step 26: Large Roof Assembly Part 2

**C:** Place 1 Roof Support Assembly against one side so the peaks meet and the ends of the roof supports are flush with the ends of the roof panels. Attach with 6 (S11) #8 x 2" Wood Screws. (fig. 26.4)

**D:** Attach the second Roof Support Assembly on the opposite side, peaks to meet and ends are flush with 6 (S11) #8 x 2" Wood Screws. (fig. 26.4)



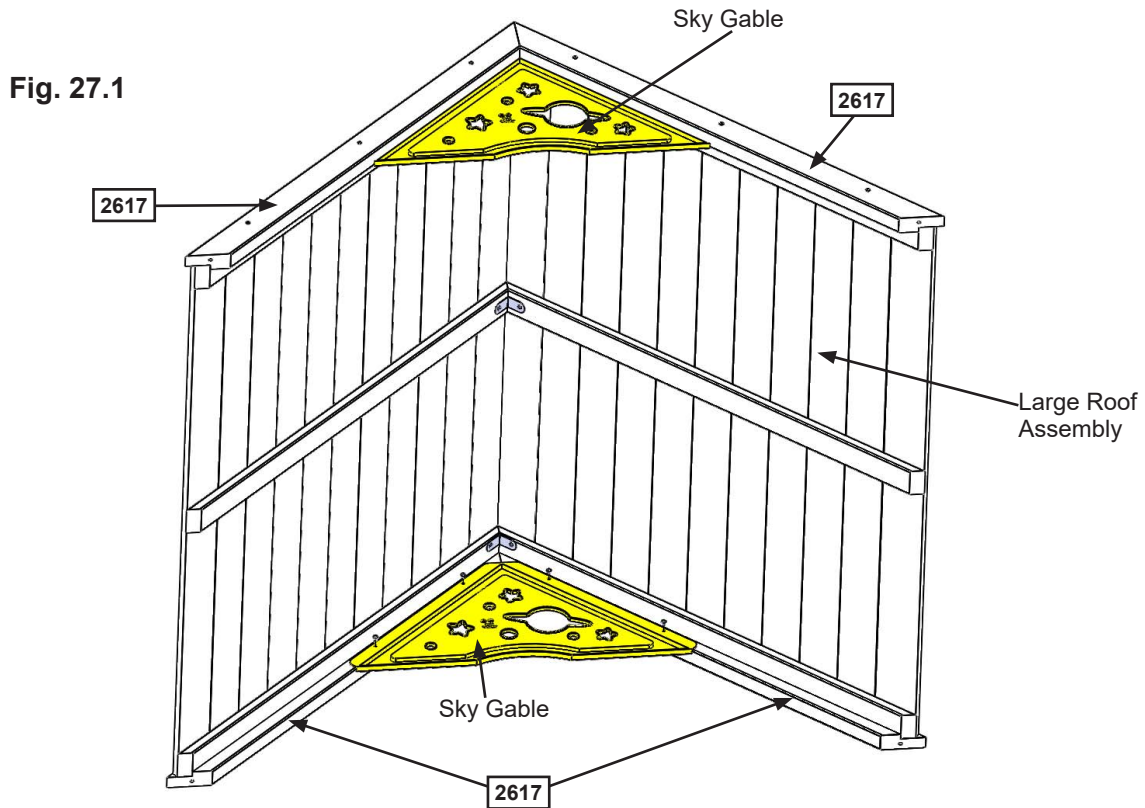
### Hardware

12 x  #8 x 2" Wood Screw

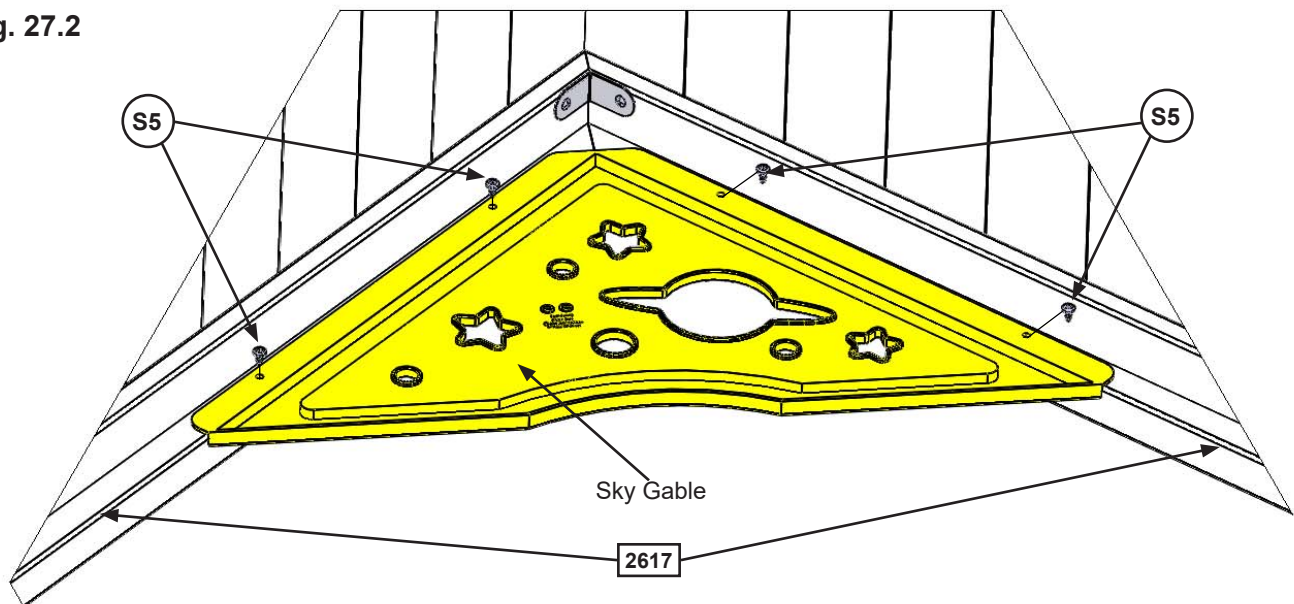


## Step 27: Attach Sky Gable


**A:** On each side of the Large Roof Assembly attach 2 Sky Gables to the inside of the (2617) Roof Supports with 4 (S5) #8 x 1/2" Pan Screws per gable. (fig. 27.1 and 27.2)



**Fig. 27.2**



### Hardware

8 x  #8 x 1/2" Pan Screw

### Other Parts

2 x Sky Gable

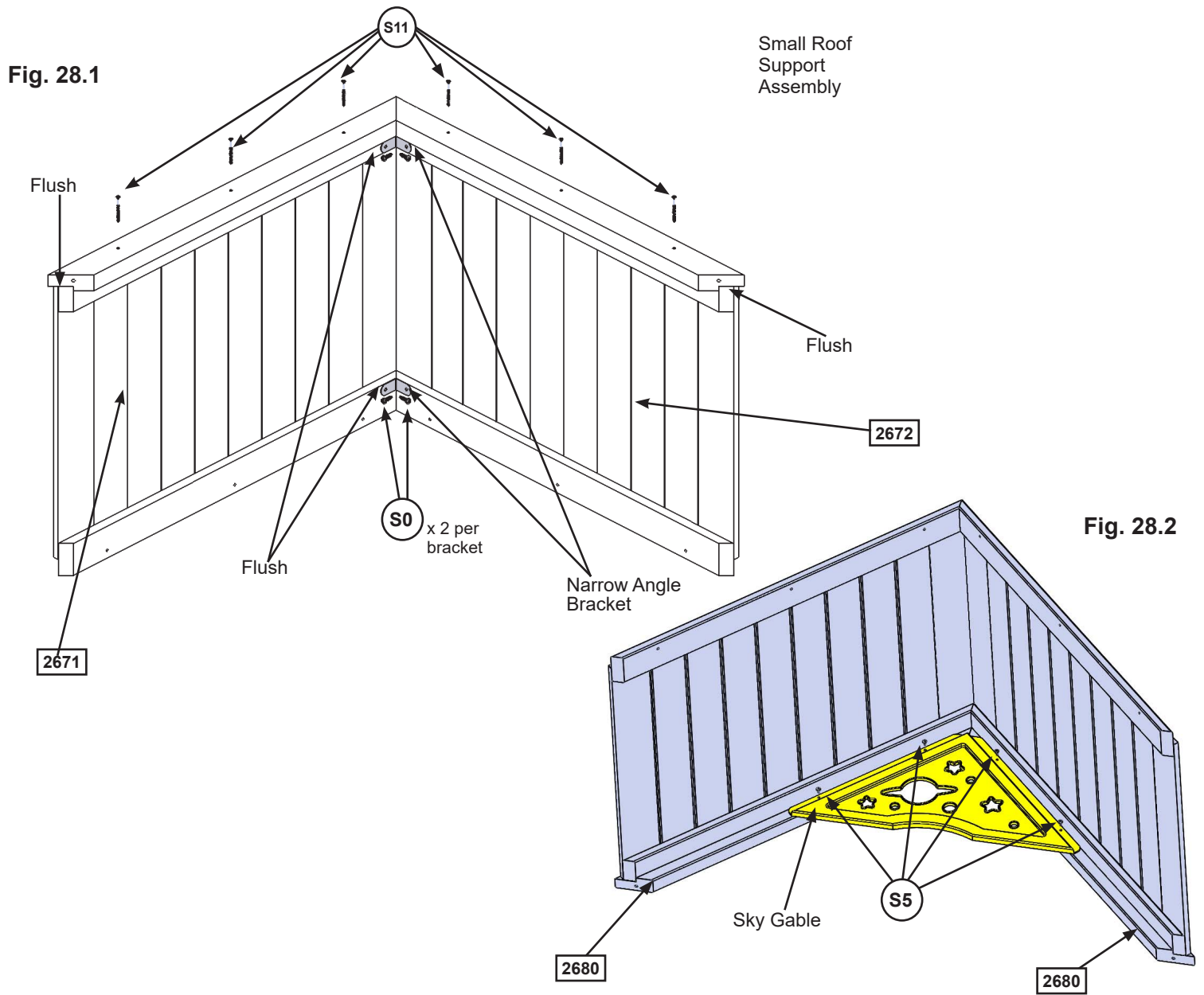
## Step 28: Small Roof Assemblies

**A:** Place (2672) Front Small Roof against (2671) Back Small Roof so the tops form a peak then tight to the inside edge of the outside slats attach 1 Narrow Angle Bracket per slat with 2 (S0) #8 x 7/8" Truss Screws per bracket. (fig. 28.1)

**B:** Place Small Roof Support Assembly against one side so the peaks meet and the ends of the roof supports are flush with the ends of the roof panels. Attach with 6 (S11) #8 x 2" Wood Screws. (fig. 28.1)

**C:** Attach 1 Sky Gable to the inside of the (2680) Roof Supports with 4 (S5) #8 x 1/2" Pan Screws. (fig. 28.2)

**D:** Repeat Steps A-C to create a second Small Roof Assembly.



### Wood Parts

- 2 x 2672 Front Small Roof 1-1/4 x 22-9/16 x 33-5/8"
- 2 x 2671 Back Small Roof 1-1/4 x 22-9/16 x 33-3/8"

### Hardware

- 12 x S11 #8 x 2" Wood Screw
- 8 x S0 #8 x 7/8" Truss Screw
- 8 x S5 #8 x 1/2" Pan Screw

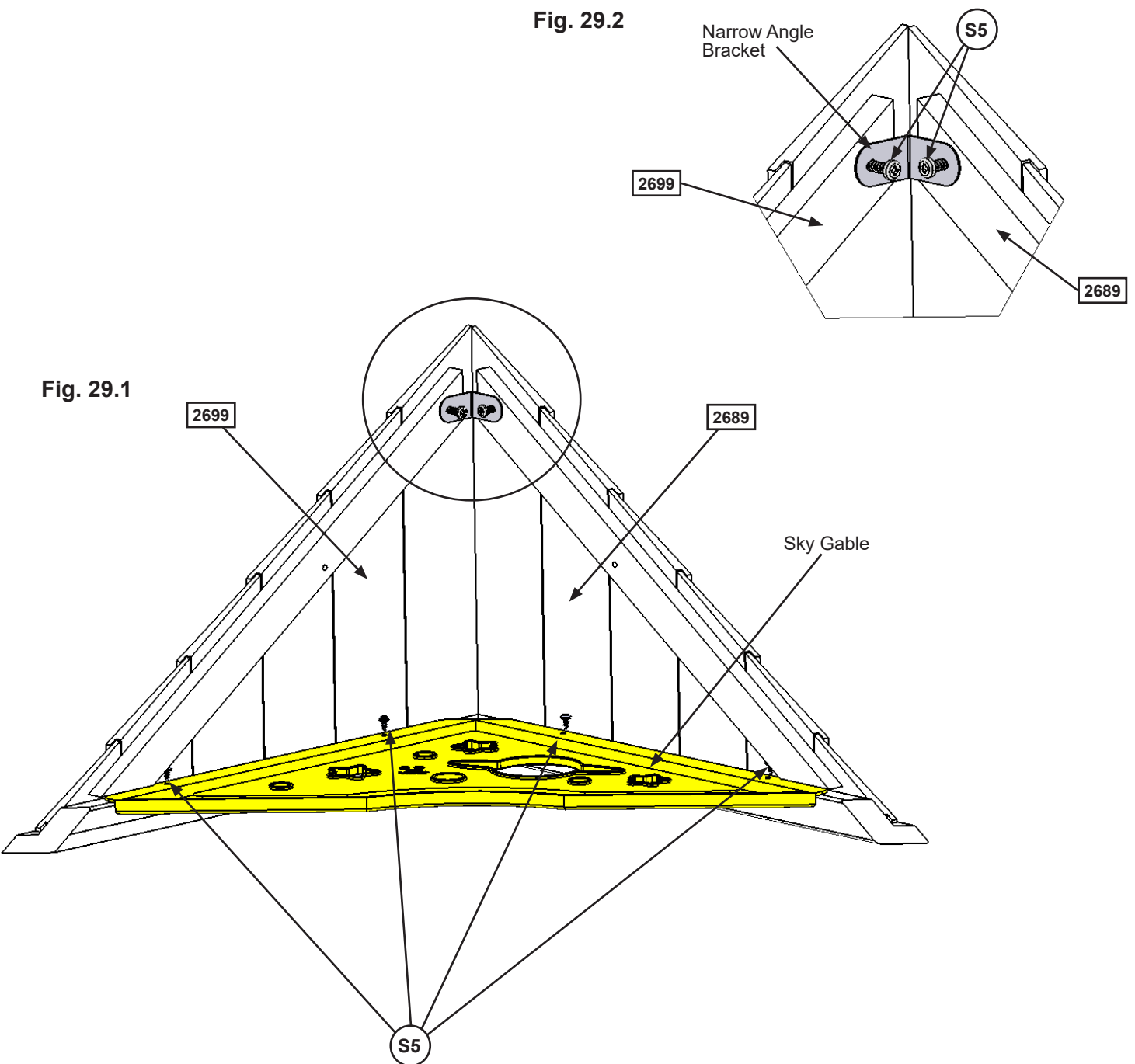
### Other Parts

- 4 x Narrow Angle Bracket
- 2 x Sky Gable

## Step 29: Gable Dormer Assembly

**A:** Place (2699) Gable Dormer RT tight to (2689) Gable Dormer LT then place Sky Gable tight against the dormers and attach with 4 (S5) #8 x 1/2" Pan Screws. (fig. 29.1)

**B:** Attach (2699) Gable Dormer RT and (2689) Gable Dormer LT with 1 Narrow Angle Bracket using 2 (S5) #8 x 1/2" Pan Screws. (fig. 29.1 and 29.2)



### Wood Parts

- 1 x 2689 Gable Dormer LT 1-1/4 x 14.6 x 22"
- 1 x 2699 Gable Dormer RT 1-1/4 x 14.6 x 22"

### Hardware

- 6 x S5 #8 x 1/2" Pan Screw

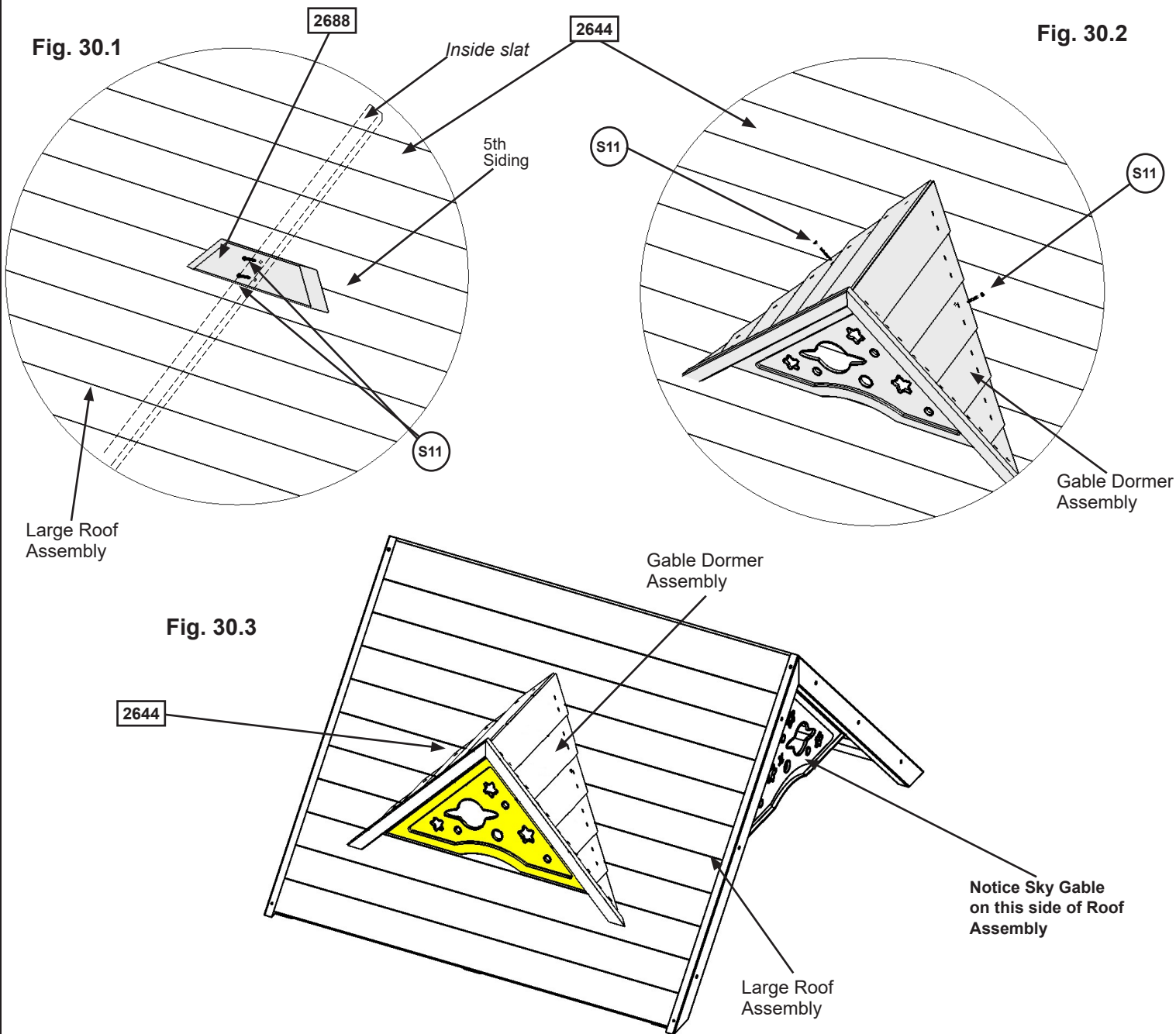
### Other Parts

- 1 x Narrow Angle Bracket
- 1 x Sky Gable

# Step 30: Attach Gable Dormer to Roof

**A:** On the outside of the Large Roof Assembly on (2644) Front Roof Panel, on the 5th siding down, place (2688) Dormer Cleat centred on the panel (over the middle inside slat) then attach with 2 (S11) #8 x 2" Wood Screws. Make sure the screws go into the siding and the slats. (fig. 30.1)

**B:** Place completed Gable Dormer Assembly over (2688) Dormer Cleat and attach with 2 (S11) #8 x 2" Wood Screws (fig. 30.2 and 30.3)



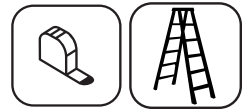
## Wood Parts

1 x 2688 Dormer Cleat 1-1/4 x 3 x 12-3/4"

## Hardware

4 x S11 #8 x 2" Wood Screw

# Step 31: Attach Roof Ends Part 1

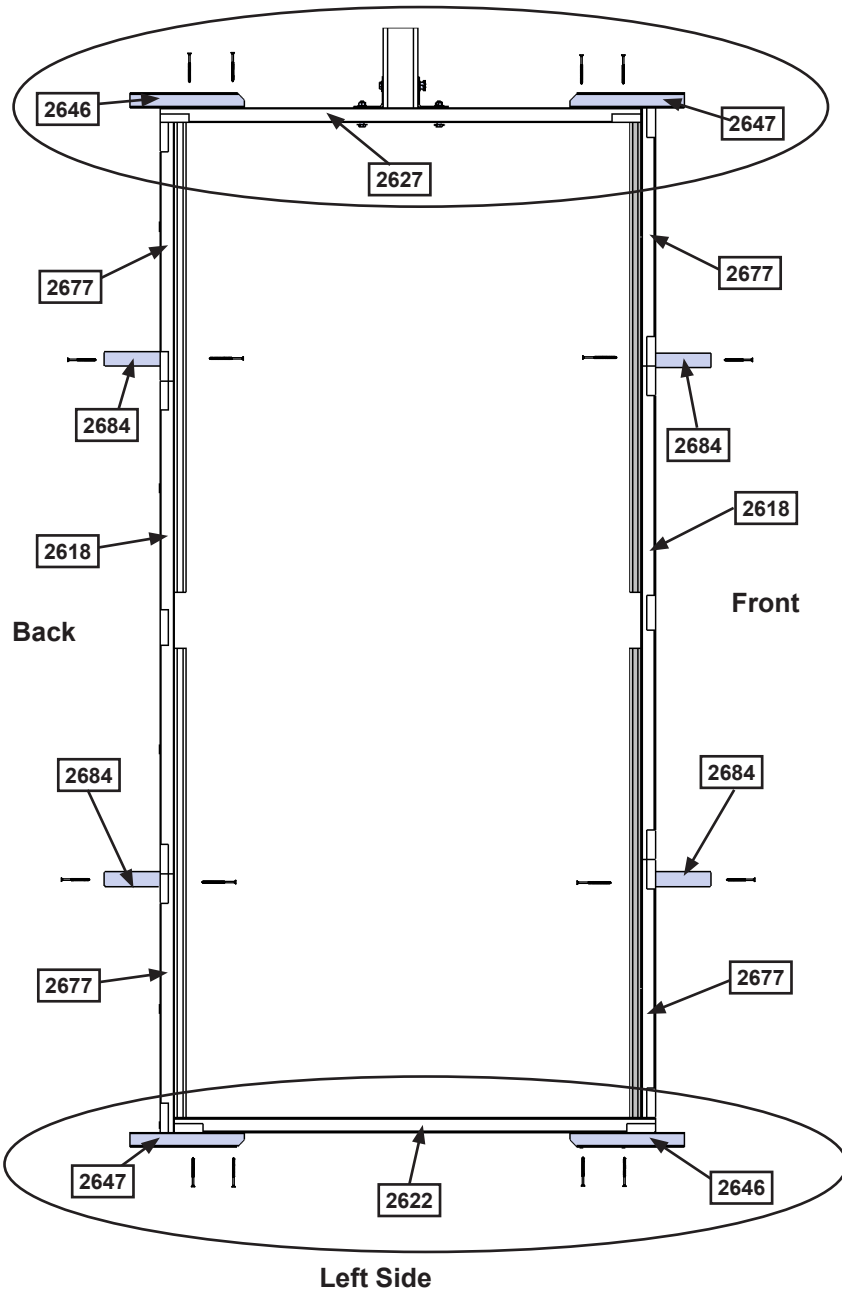


**A:** On (2627) SW Wall Panel and (2622) End Panel Assembly place 1 (2646) Roof End flush to the top of the panel on the right hand side, measure overhang so it is 2-5/8" then attach with 3 (S11) #8 x 2" Wood Screws per board. (fig. 31.1, 31.2 and 31.3)

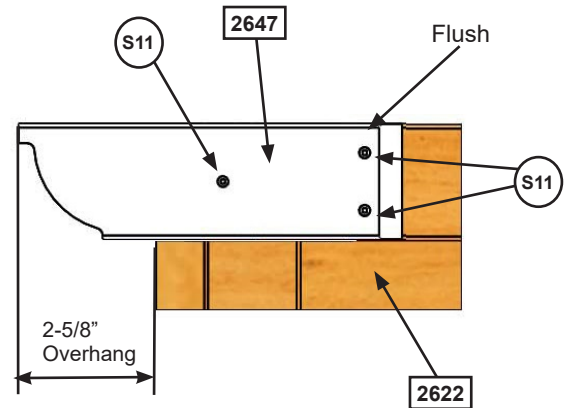
**B:** Repeat Step A for 2 (2647) Roof End Lefts. (fig. 31.1, 31.2 and 31.3)

**Fig. 31.1**

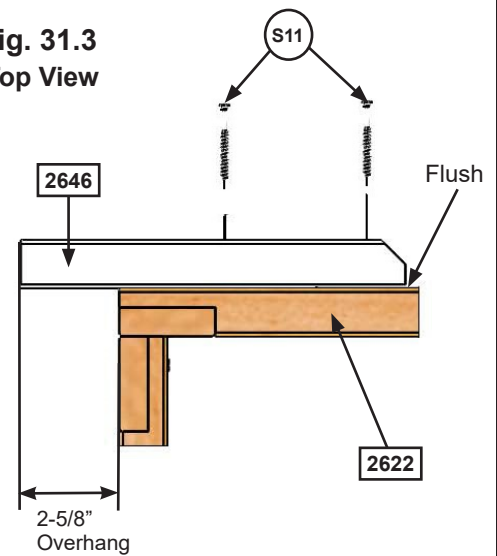
**Swing Wall**



**Fig. 31.2**  
**Side View**



**Fig. 31.3**  
**Top View**



**Wood Parts**

- 2 x 2646 Roof End 1-1/4 x 3 x 10"
- 2 x 2647 Roof End Left 1-1/4 x 3 x 10"

**Hardware**

- 12 x (S11) #8 x 2" Wood Screw

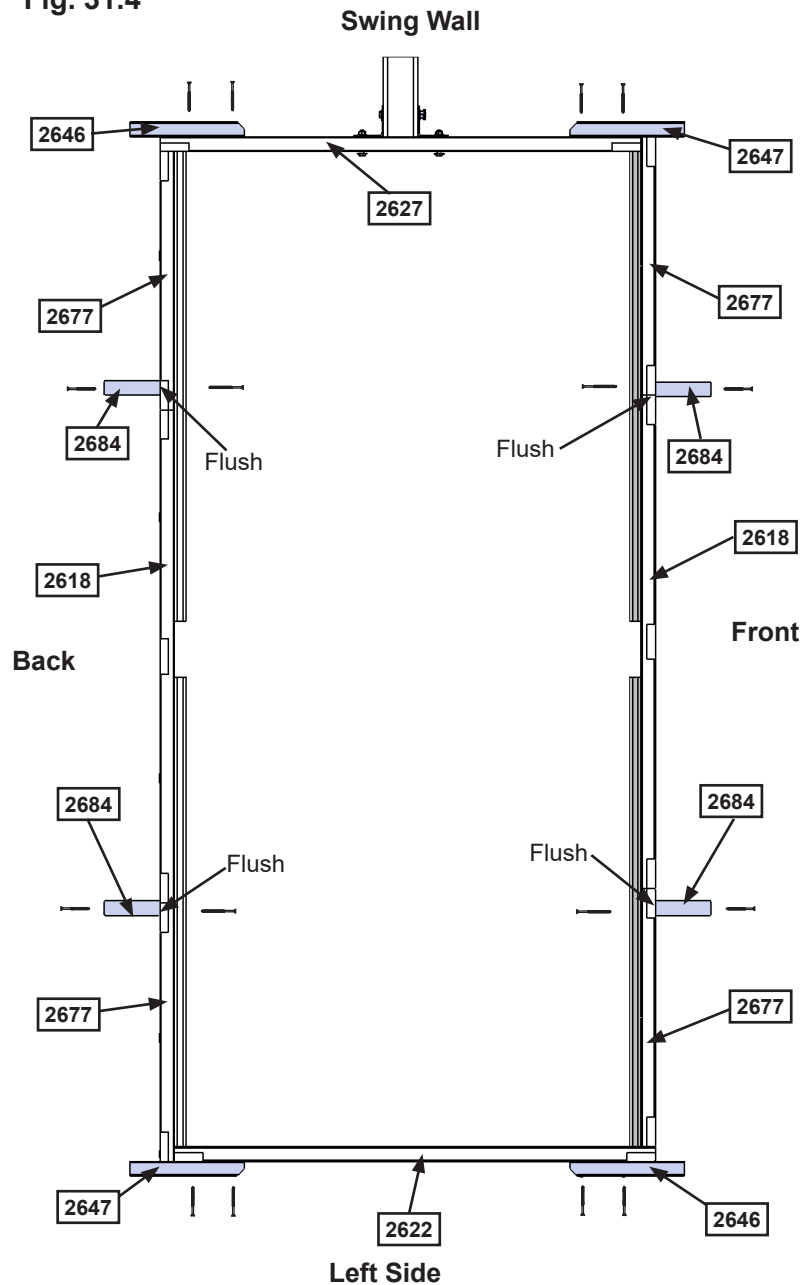
# Step 31: Attach Roof Ends Part 2



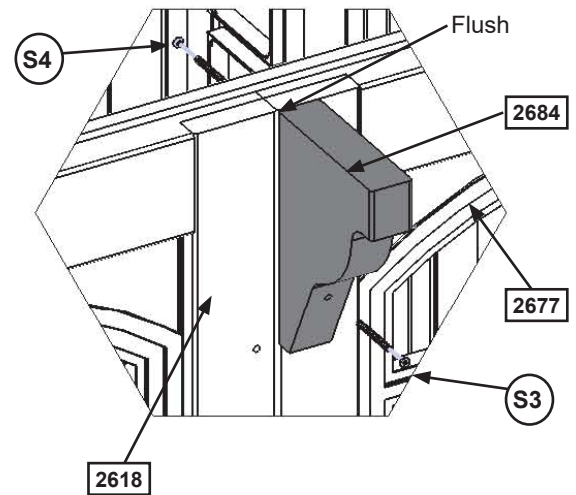
**C:** On the Back of the fort place 1 (2684) Mid Roof End flush to the top of each (2677) Narrow Panel centred over the pilot holes then measure 1-1/4" down from the top of the panel and attach from the inside with 1 (S4) #8 x 3" Wood Screw and from the outside with 1 (S3) #8 x 2-1/2" Wood Screw per Mid Roof End. (fig. 31.4 and 31.5)

**D:** On the Front of the fort place 1 (2684) Mid Roof End flush to the top of each (2677) Narrow Panel centred over the pilot holes then measure 1-1/4" down from the top of the panel and attach from the inside with 1 (S4) #8 x 3" Wood Screw and from the outside with 1 (S3) #8 x 2-1/2" Wood Screw per Mid Roof End. (fig. 31.4 and 31.6)

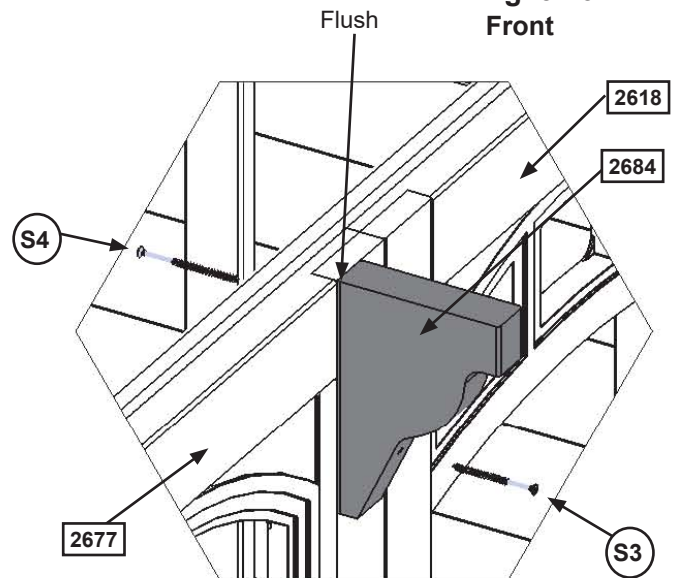
**Fig. 31.4**



**Fig. 31.5  
Back**



**Fig. 31.6  
Front**



**Wood Parts**

4 x **2684** Mid Roof End 1-1/4 x 4-7/8 x 7"

**Hardware**

4 x **S3** #8 x 2-1/2" Wood Screw

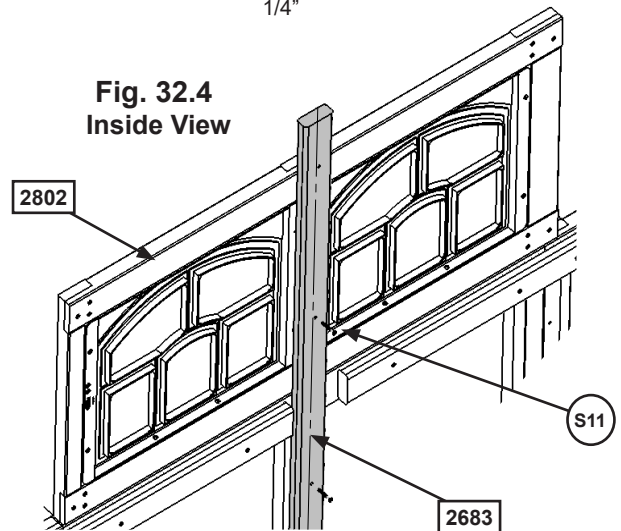
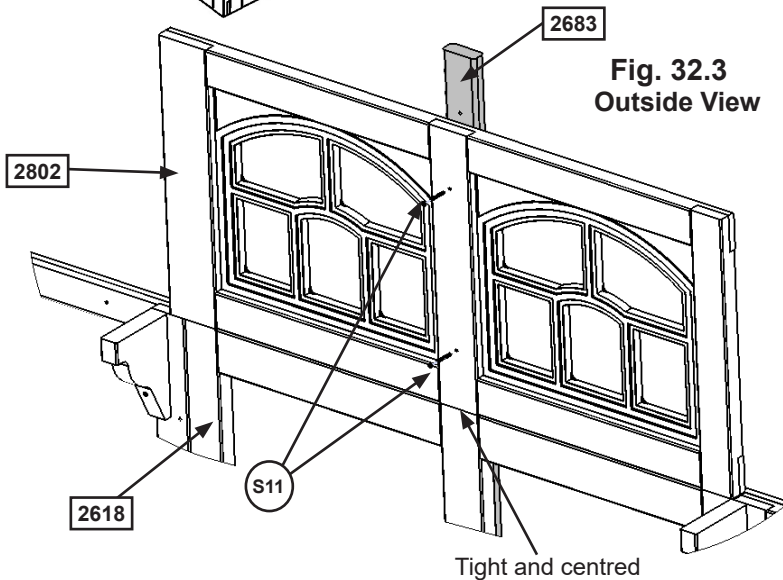
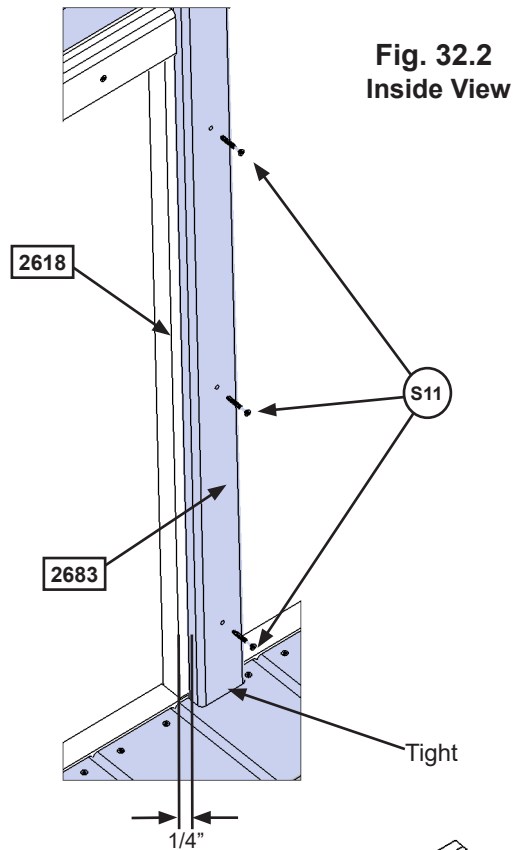
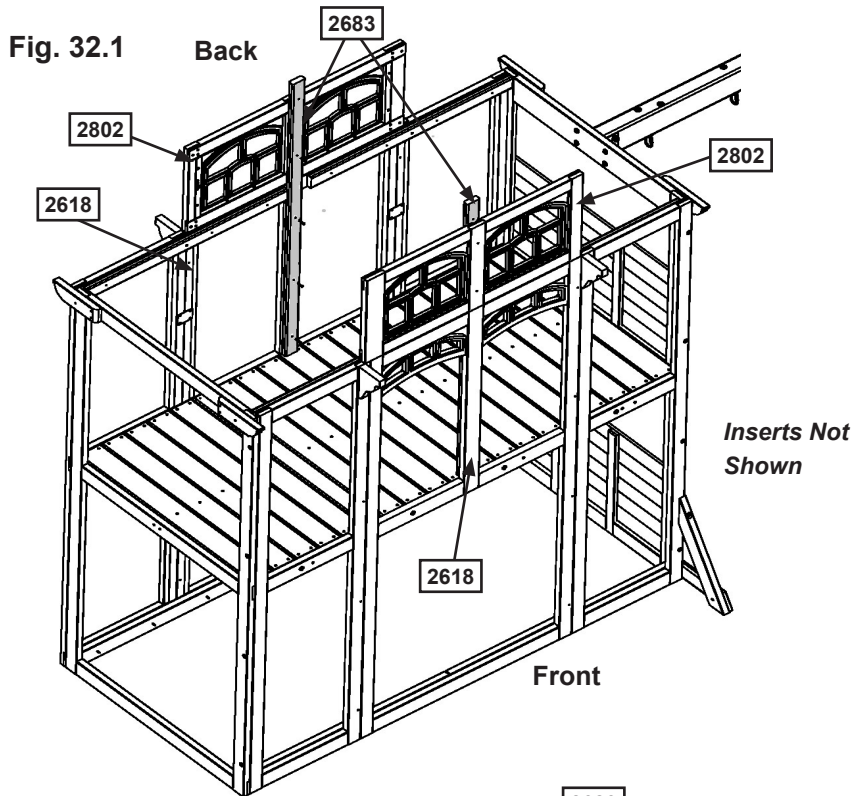
4 x **S4** #8 x 3" Wood Screw

# Step 32: Upper Window Installation



**A:** On the Front and Back Walls place 1 (2683) Wall Tie tight to the top of the floor boards and 1/4" in from both sides of the centre board in each (2618) Front Back Panel then attach with 3 (S11) #8 x 2" Wood Screws. (fig. 32.1 and 32.2)

**B:** Tight to the top of each (2618) Front Back Panel over each (2683) Wall Tie place 1 (2802) Transom Window on each panel and attach with 1 (S11) #8 x 2" Wood Screw from the inside and 2 (S11) #8 x 2" Wood Screws from the outside per (2802) Transom Window. (fig. 32.1, 32.3 and 32.4)



### Wood Parts

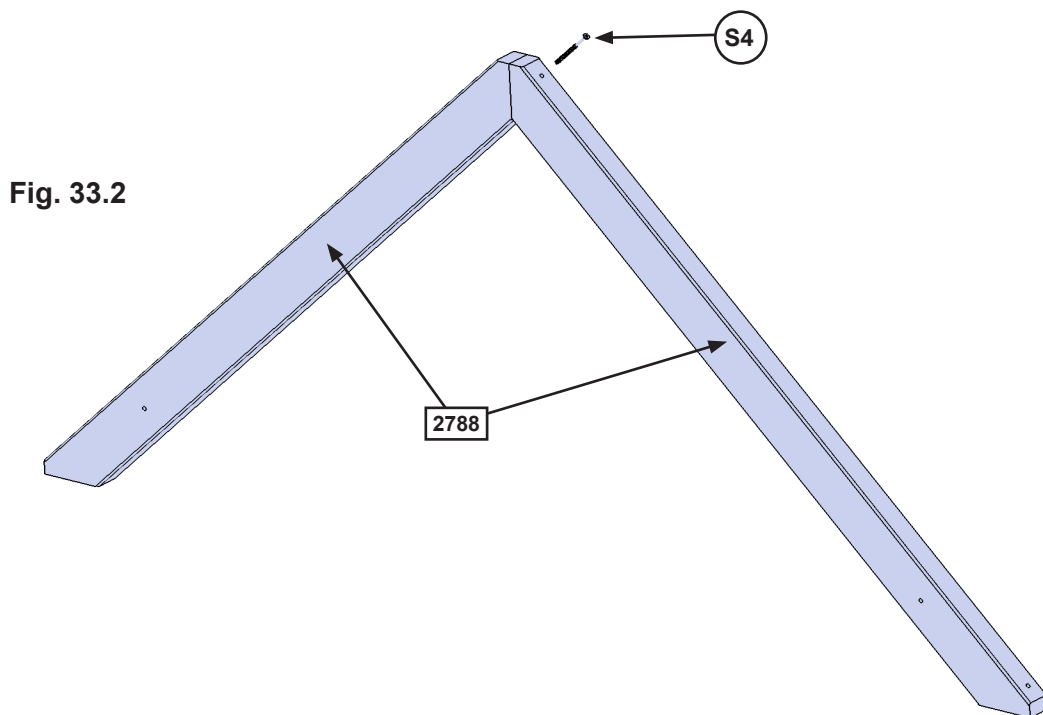
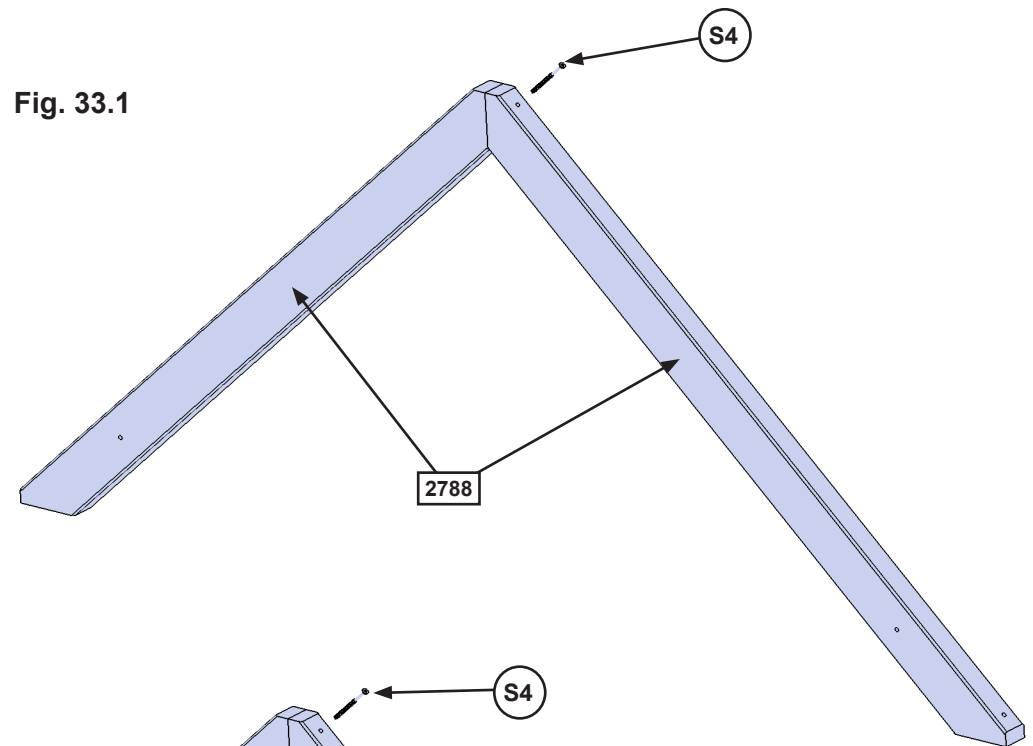
- 2 x 2683 Wall Tie 5/4 x 3 x 62-5/8"
- 2 x 2802 Transom Window 1-1/4 x 19 x 43"

### Hardware

- 12 x S11 #8 x 2" Wood Screw

## Step 33: Mid Roof Support Assemblies

**A:** Attach 1 (2788) Mid Roof Support to a second (2788) Mid Roof Support at peak using 1 (S4) #8 x 3" Wood Screw. Repeat this step so there are 2 Mid Roof Support Assemblies. (fig. 33.1 and 33.2)



### Wood Parts

4 x Mid Roof Support 1-1/4 x 2-1/2 x 37-1/8"

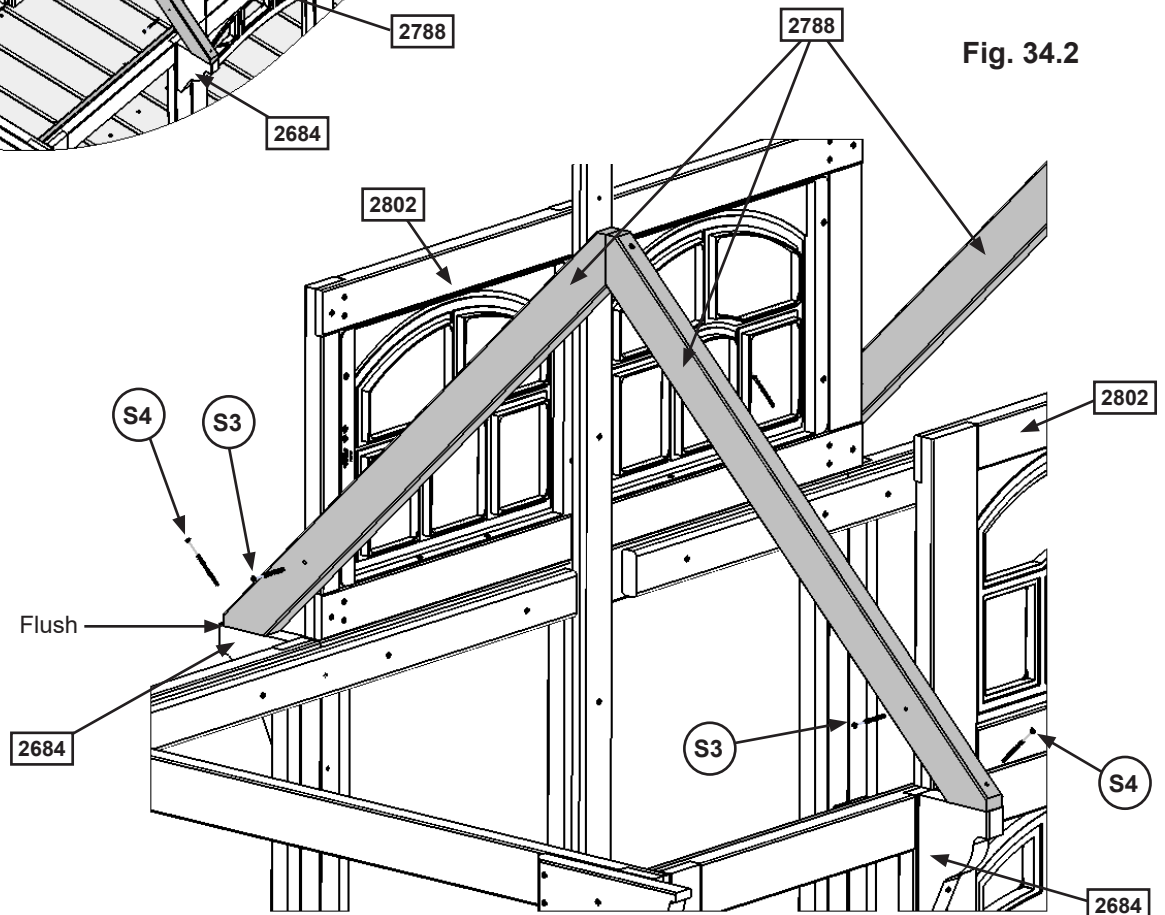
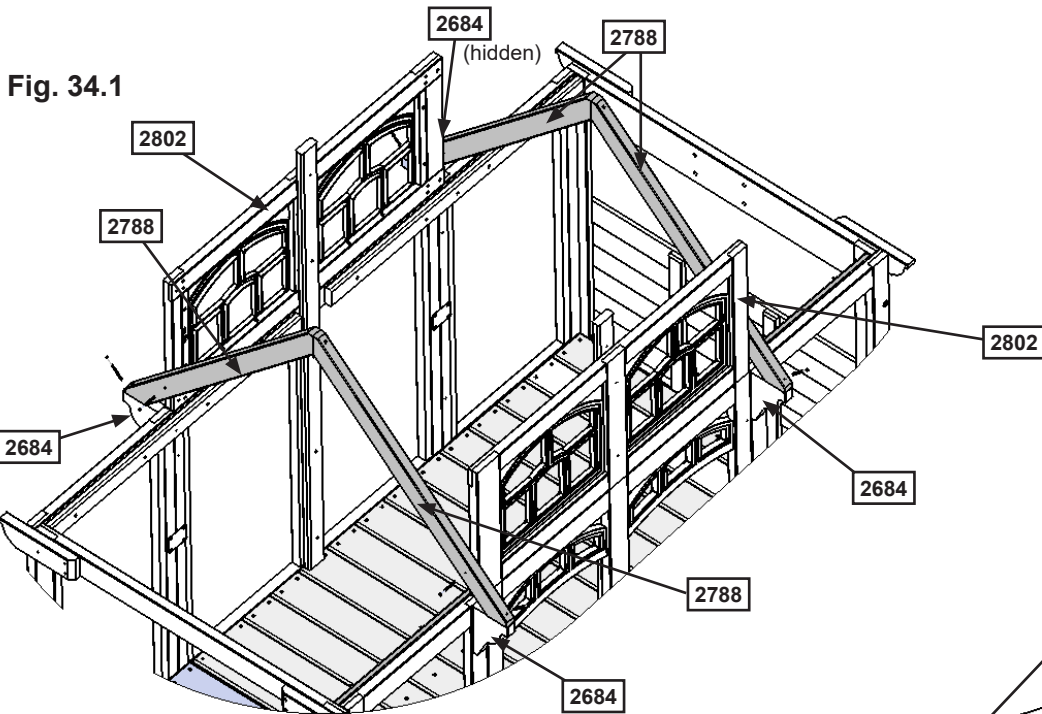
### Hardware

2 x #8 x 3" Wood Screw



## Step 34: Attach Mid Roof Support Assemblies

**A:** Place 1 Mid Roof Support Assembly on each side of the (2802) Transom Windows and flush to the ends of each (2684) Mid Roof End then attach to (2802) Transom Window using 2 (S3) #8 x 2-1/2" Wood Screws per (2788) Mid Roof Support and to each (2684) Mid Roof End with 1 (S4) #8 x 3" Wood Screw per side. (fig. 34.1 and 34.2)

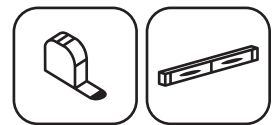


### Hardware

4 x (S3) #8 x 2-1/2" Wood Screw

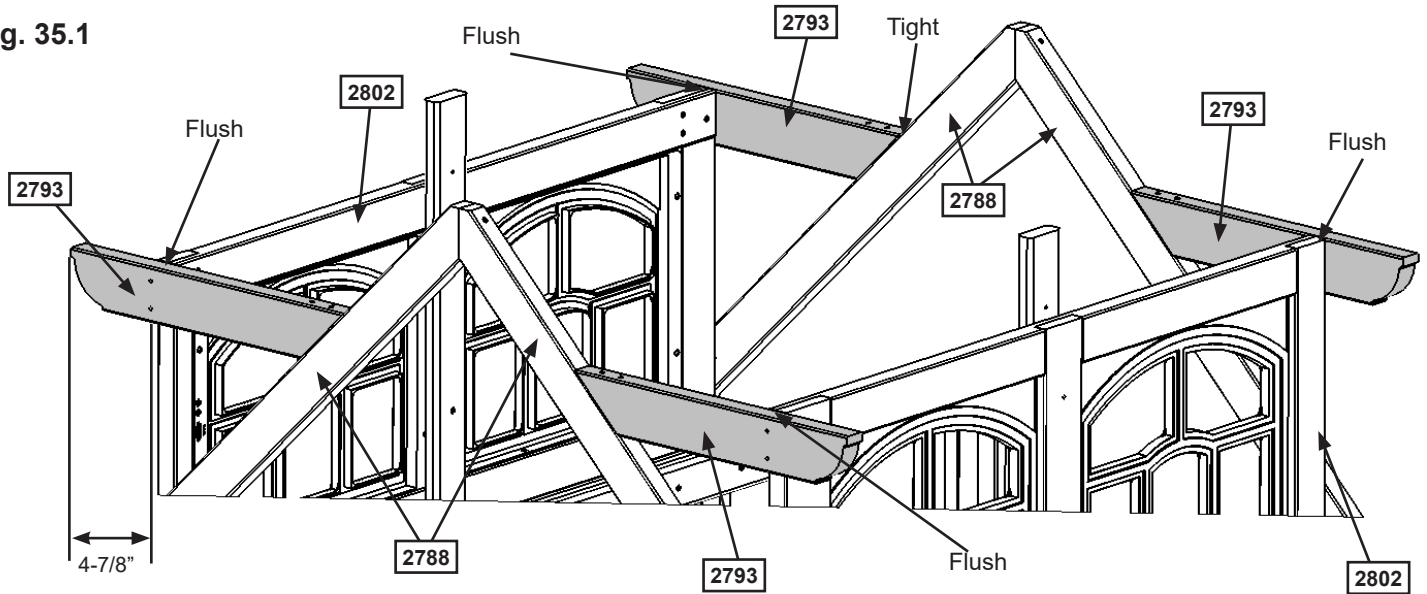
4 x (S4) #8 x 3" Wood Screw

# Step 35: Attach Long Roof Ends

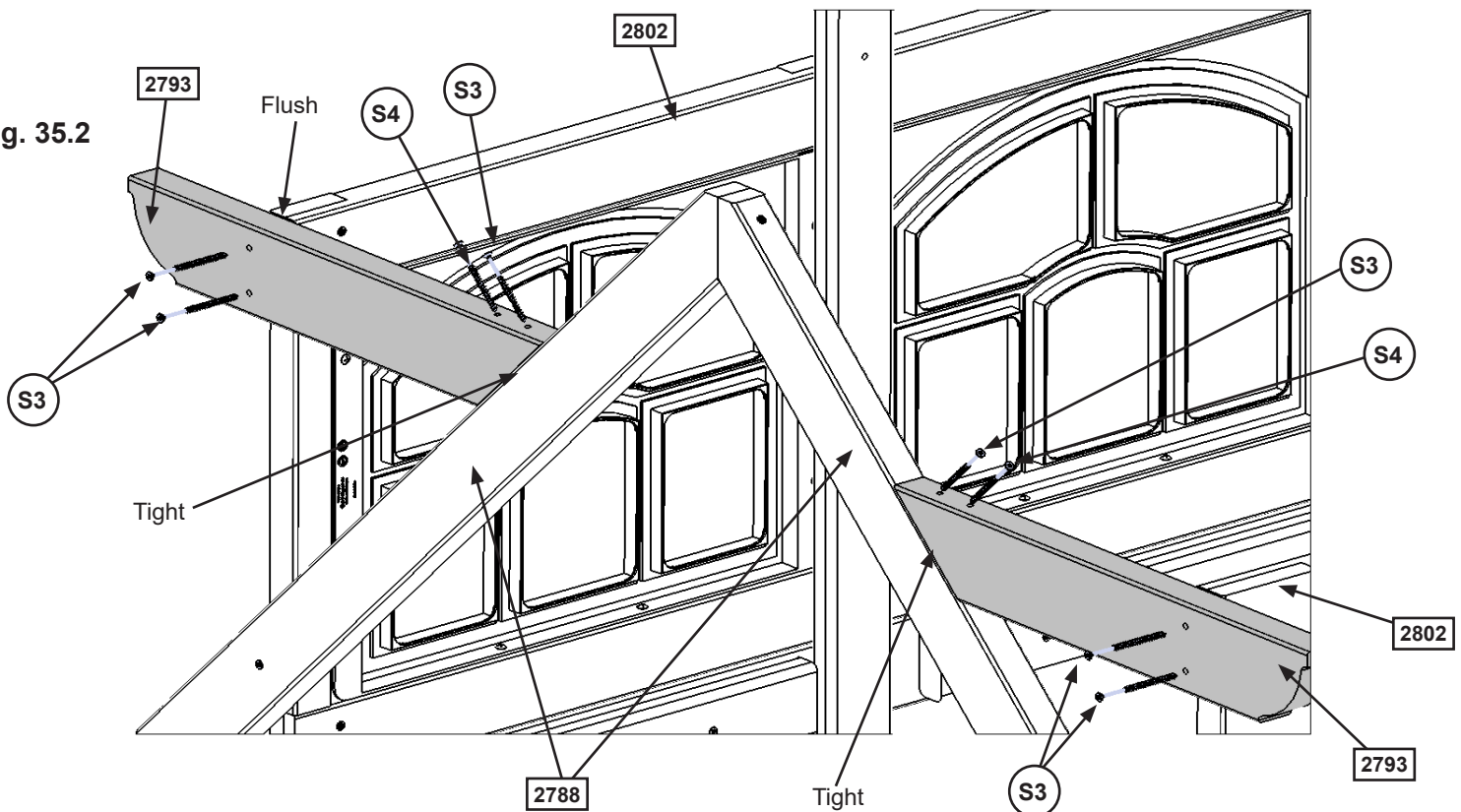


**A:** Place 1 (2793) Long Roof End tight to each (2788) Mid Roof Support and flush to the top of (2802) Transom Window. Make sure (2793) Long Roof End is level and the overhang at each end measures 4-7/8", then attach to (2788) Mid Roof Supports with 1 (S3) #8 x 2-1/2" Wood Screws and 1 (S4) #8 x 3" Wood Screw per support and to each side of the (2802) Transom Windows using 2 (S3) #8 x 2-1/2" Wood Screws per side. (fig. 35.1 and 35.2)

**Fig. 35.1**



**Fig. 35.2**



**Wood Parts**

4 x **2793** Long Roof End 1-1/4 x 3 x 18-3/4"

**Hardware**

12 x **S3** #8 x 2-1/2" Wood Screw

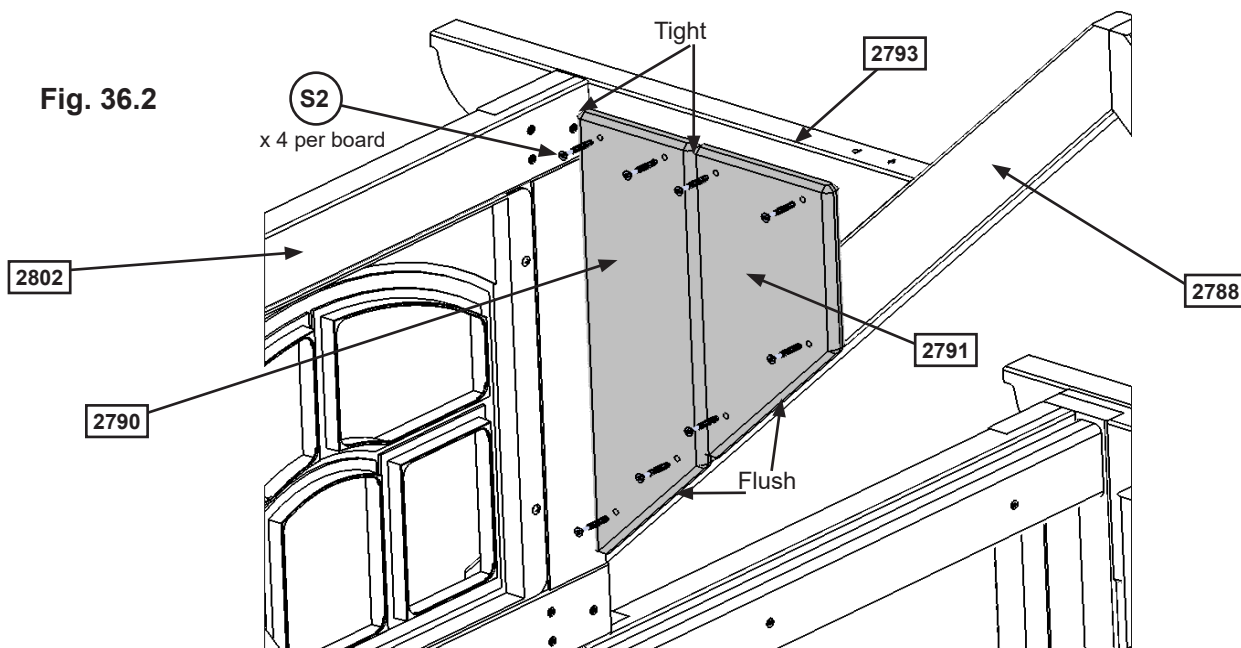
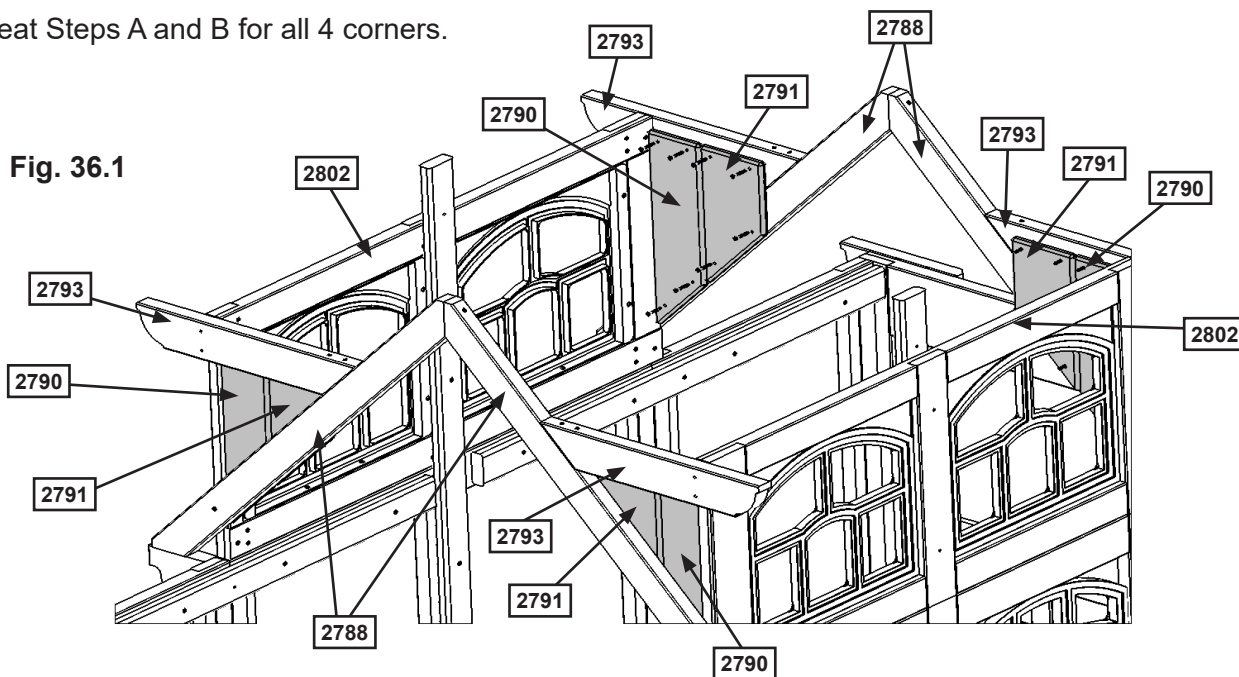
4 x **S4** #8 x 3" Wood Screw

# Step 36: Attach Transom Boards

**A:** Tight to (2802) Transom Window and flush to the bottom of (2788) Mid Roof Support attach 1 (2790) Transom Board A to (2788) Mid Roof Support and (2793) Long Roof End with 4 (S2) #8 x 1-1/2" Wood Screws. (fig. 36.1 and 36.2)

**B:** Tight to (2790) Transom Board A and flush to the bottom of (2788) Mid Roof Support attach 1 (2791) Transom Board B to (2788) Mid Roof Support and (2793) Long Roof End with 4 (S2) #8 x 1-1/2" Wood Screws. (fig. 36.1 and 36.2)

**C:** Repeat Steps A and B for all 4 corners.



## Wood Parts

- 4 x 2790 Transom Board A 1 x 5 x 15-1/2"
- 4 x 2791 Transom Board B 1 x 6 x 11"

## Hardware

- 32 x S2 #8 x 1-1/2" Wood Screw

# Step 37: Attach Roof Assemblies to Fort Part 1

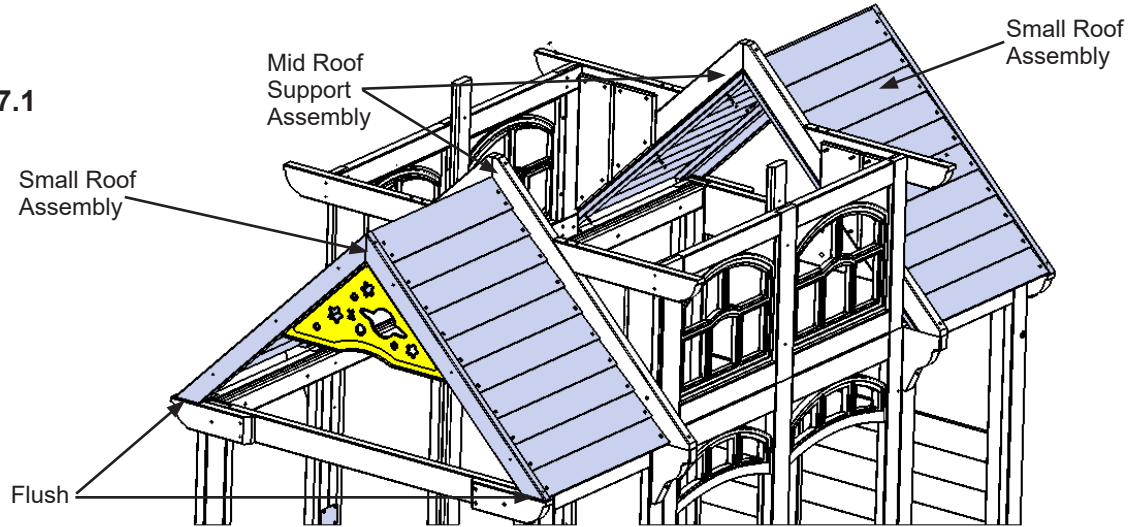


**A:** With 2 people on the ground and at least 1 person in the fort, lift one Small Roof Assembly up and over the Back side of the fort. Guide the Small Roof Assembly onto the fort so it slides under one of the Mid Roof Support Assemblies and the (2788) Mid Roof Supports sit tight to the siding on the Small Roof Assembly. The front of the Small Roof Assembly should be flush to the front of each (2646) Roof End and (2647) Roof End Left. (fig. 37.1 and 37.2)

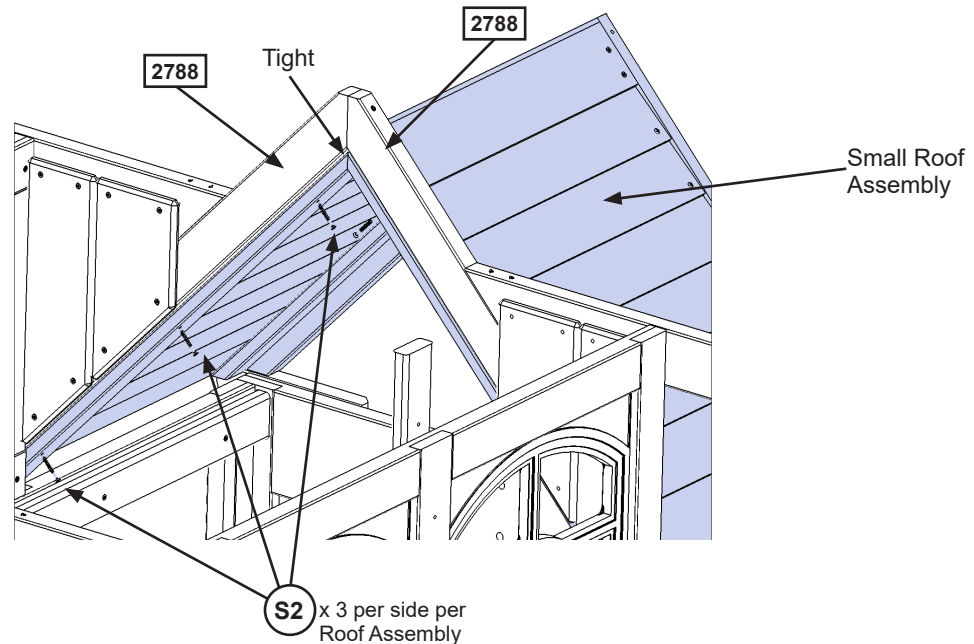
**B:** Attach Small Roof Assembly to Mid Roof Support Assembly from inside with 3 (S2) #8 x 1-1/2" Wood Screws per side. Screws to go into (2788) Mid Roof Supports. (fig. 37.2)

**C:** Repeat Steps A and B for the second Small Roof Assembly.

**Fig. 37.1**



**Fig. 37.2**



## Hardware

12 x (S2) #8 x 1-1/2" Wood Screw

# Step 37: Attach Roof Assemblies to Fort Part 2

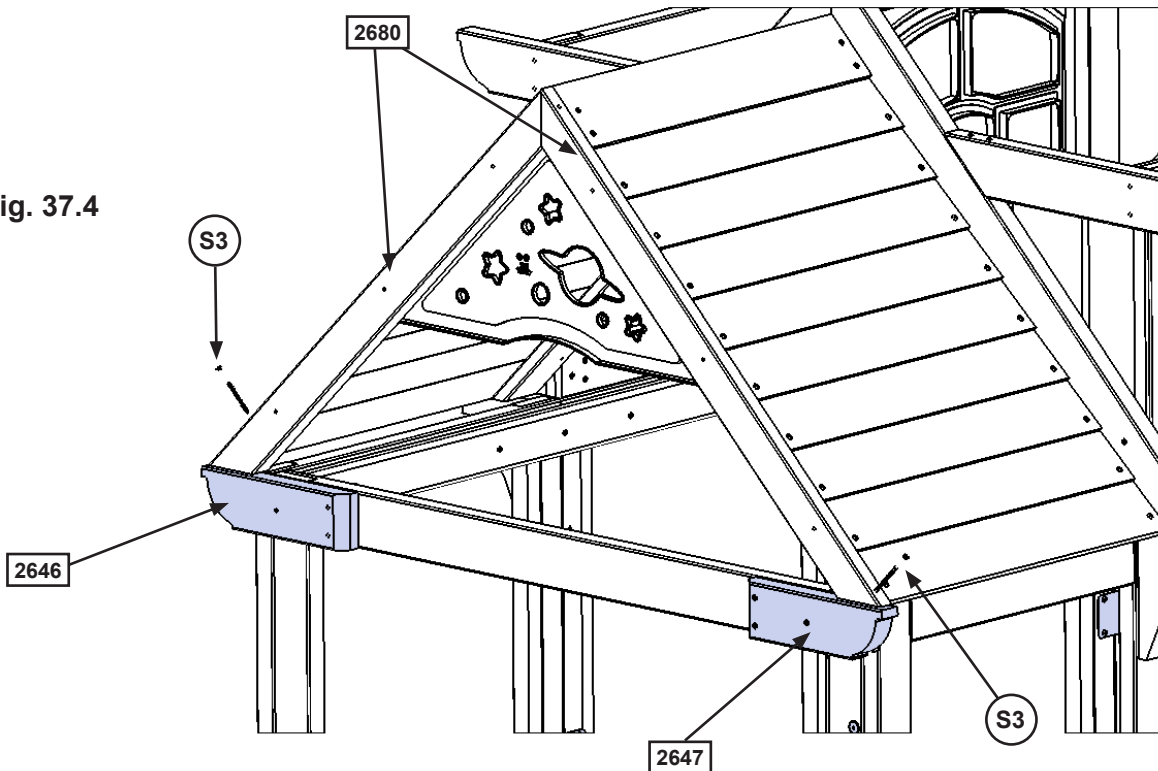


**D:** Attach (2680) Roof Supports to (2646) Roof Ends and (2647) Roof End Lefts with 1 (S3) #8 x 2-1/2" Wood Screw per support. (fig. 37.3 and 37.4)

Fig. 37.3



Fig. 37.4



### Hardware

4 x (S3) #8 x 2-1/2" Wood Screw

# Step 37: Attach Roof Assemblies to Fort Part 3



**E:** With 2 people on the ground and at least 1 person in the fort, lift the Large Roof Assembly up and over the Back side of the fort. Guide the Roof Assembly onto the fort so all four (2617) Roof Supports sit flush to the front and outside edges of each (2793) Long Roof End. (fig. 37.5 and 37.6)

**F:** Attach (2617) Roof Supports to each (2793) Long Roof End with 1 (S3) #8 x 2-1/2" Wood Screw per support. (fig.37.5 and 37.6)

Fig. 37.5

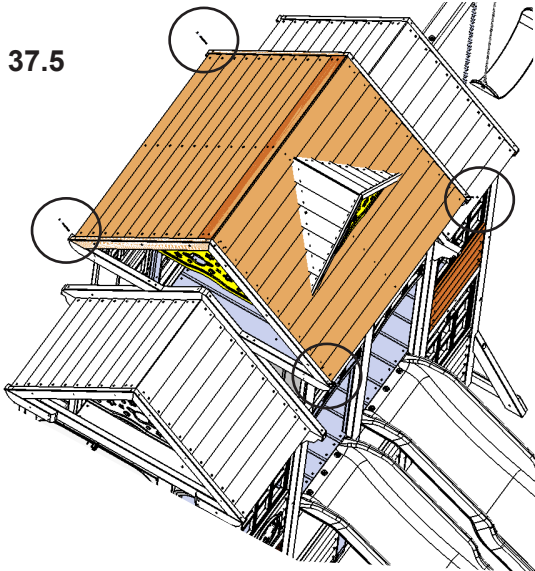
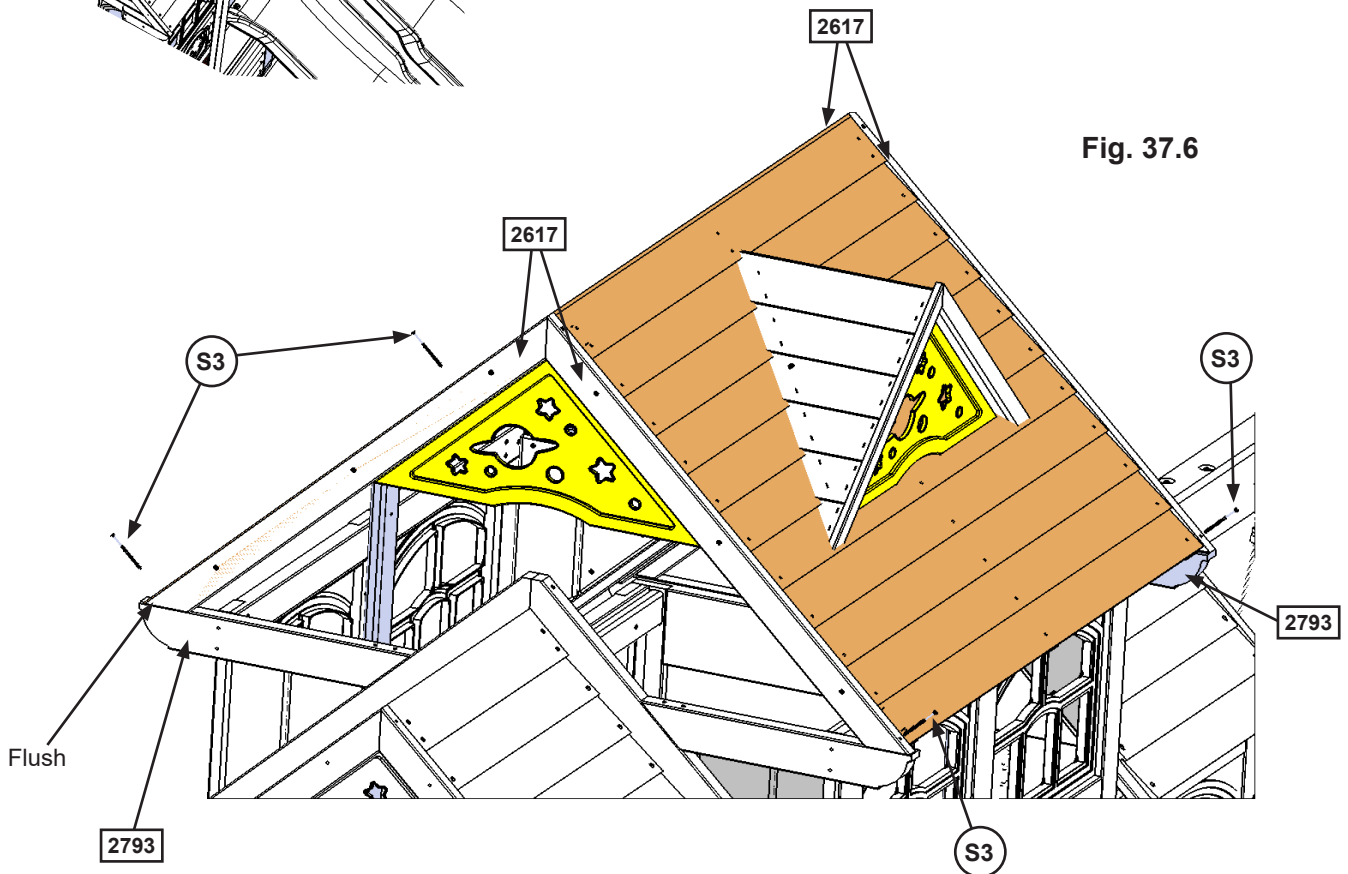


Fig. 37.6



## Hardware

4 x (S3) #8 x 2-1/2" Wood Screw

# Step 37: Attach Roof Assemblies to Fort Part 4

**G:** Attach each (2683) Wall Tie to the middle roof rafters of the Large Roof Assembly with 1 Spiral Wave Bracket and 3 (S8) #12 x 3/4" Pan Screws per side. (fig. 37.7 and 37.8)

Fig. 37.7

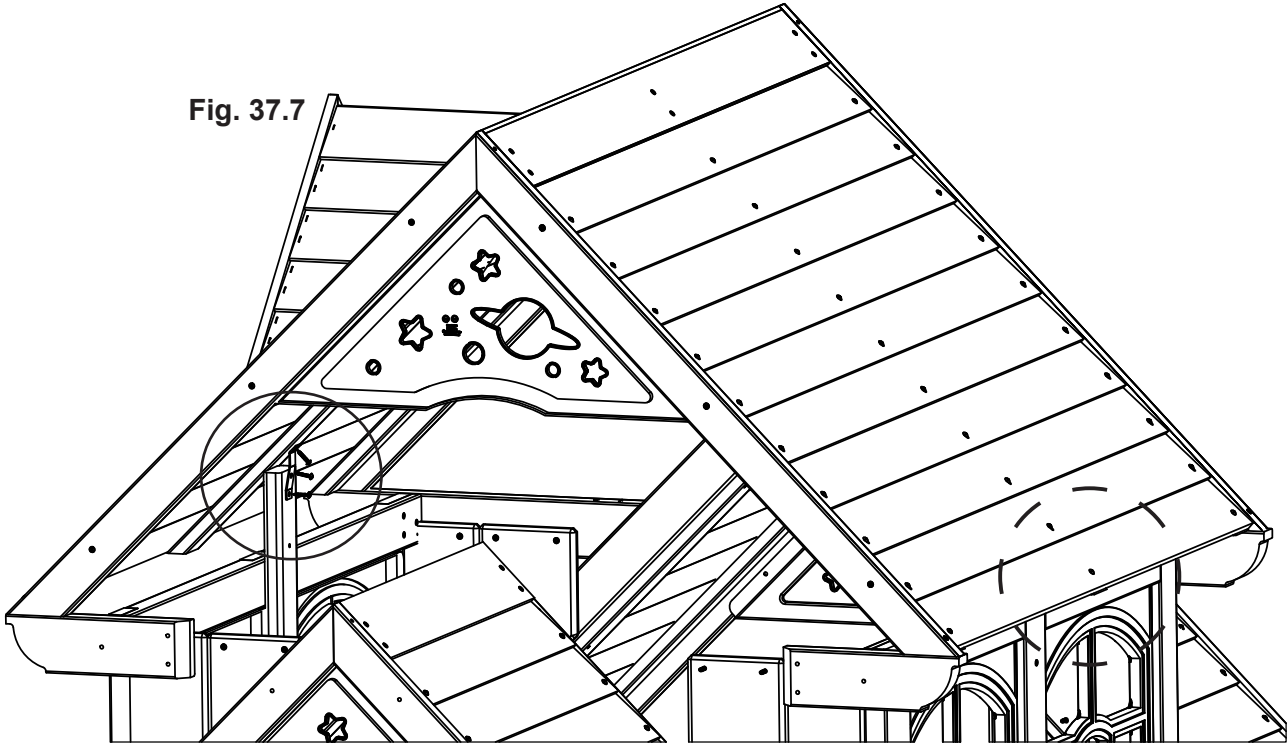
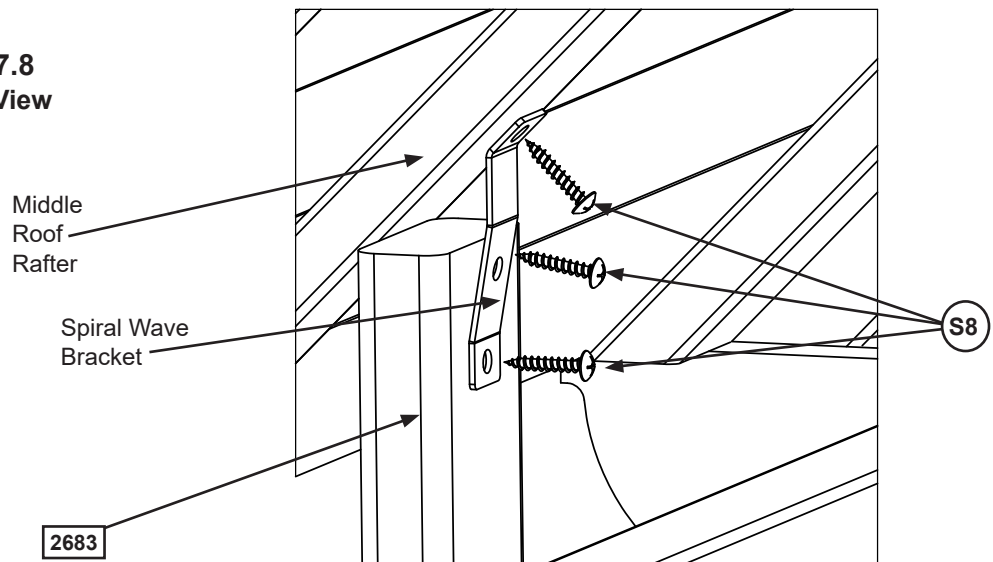



Fig. 37.8  
Inside View



### Hardware

6 x  #12 x 3/4" Pan Screw

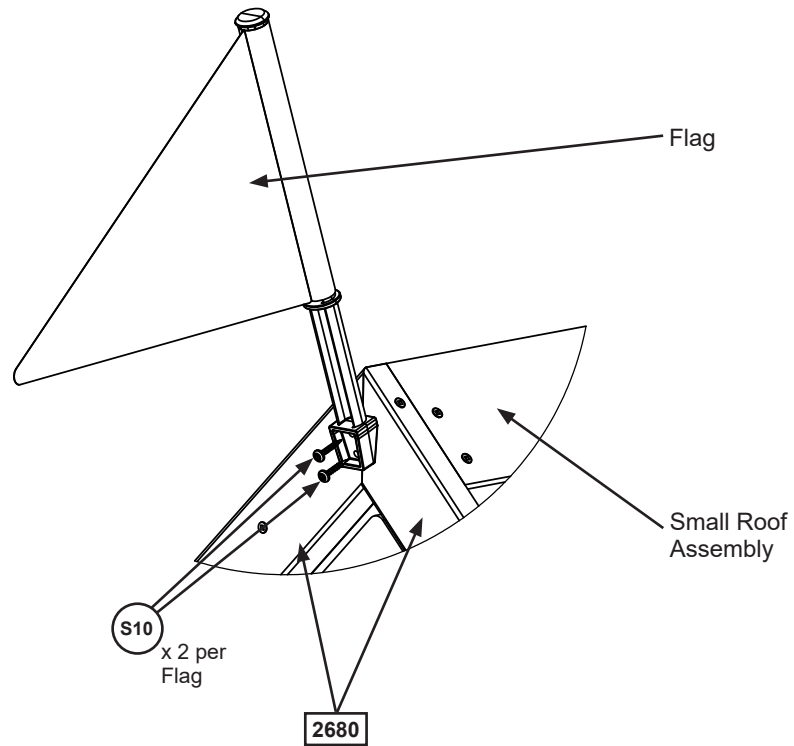
### Other Parts

2 x Spiral Wave Bracket

## Step 38: Attach Flags

**A:** Place 1 Flag at the peak of each Small Roof Assembly and attach to (2680) Roof Supports with 2 (S10) #8 x 1" Pan Screws per flag. (fig. 38.1)

Fig. 38.1



### Hardware

4 x (S10) #8 x 1" Pan Screw

### Other Parts

2 x Flag



# Adventure Tower Assembly

## Step 39: Upper Frame Assembly

**A:** Place 1 (6012) Short Post and 1 (6000) Upper Post side by side with the (6012) Short Post on the left side making sure that the notched out end is at the bottom and facing the outside. Place (6023) Roof Side at the top of the posts so that it's flush and attach using 2 (H2) 1/4 x 2" Hex Bolts (with lock washer, flat washer and t-nuts). (Fig. 39.1)

**B:** Place (6029) Side Top so it lines up with the lower pre-drilled holes on the posts and attach using 2 (H2) 1/4 x 2" Hex Bolts (with lock washer, flat washer and t-nuts). (Fig. 39.1)

**C:** To make a second partial upper frame assembly place 1 (6012) Short Post and 1 (6000) Upper Post side by side with the (6012) Short Post on the right side, notched side facing out and the (6000) Upper Post on the left side. Place (6023) Roof Side at the top of the posts making sure it's flush and attach using 2 (H2) 1/4x 2" Hex Bolts (with lock washer, flat washer and t-nuts). (Fig. 39.2)

**D:** Place (6030) Tunnel Side Top so it lines up with the lower pre-drilled holes on the posts and attach using 2 (H2) 1/4 x 2" Hex Bolts (with lock washer, flat washer and t-nuts). (Fig. 39.2)

**Set the upper assemblies aside, they will not be used until a later step.**

Fig. 39.1

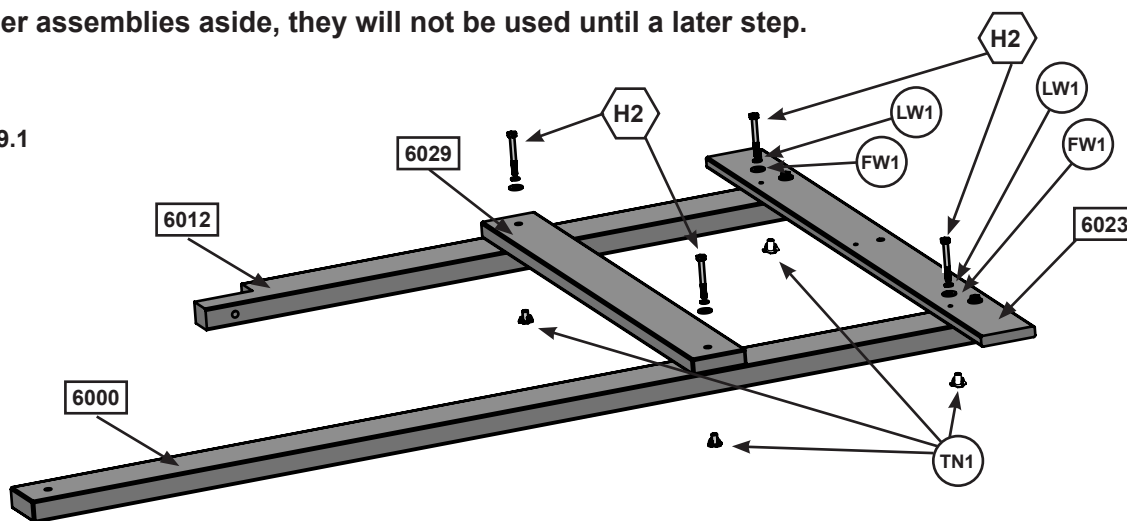
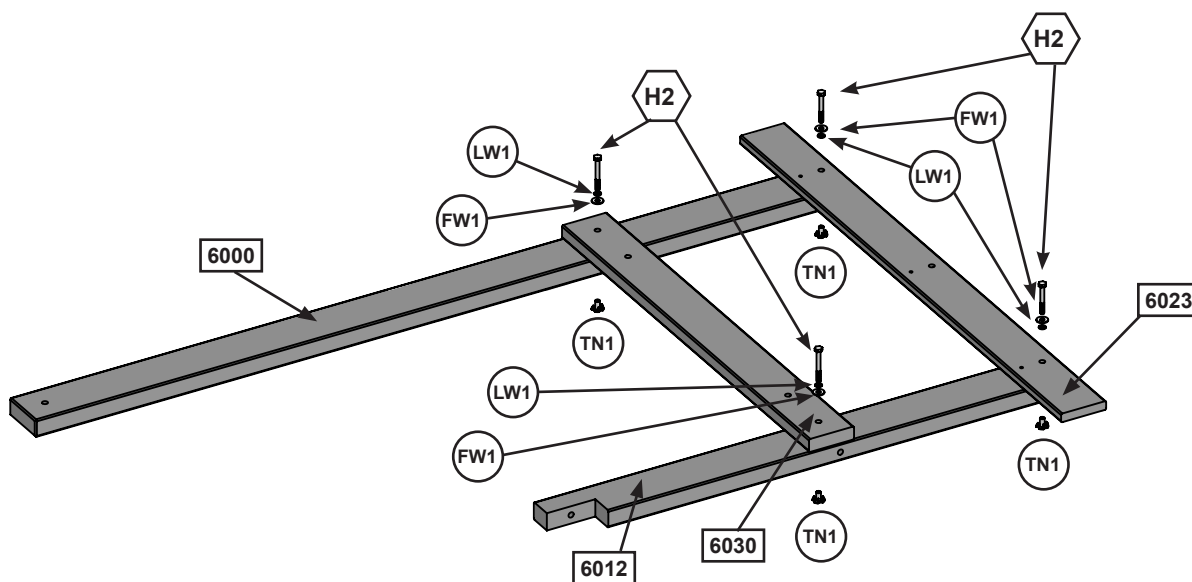


Fig. 39.2



### Wood Parts

- 2 x [6000] Upper Post 1-1/4 x 3-1/4 x 58-7/8"
- 2 x [6012] Short Post 1-1/4 x 3-1/4 x 36-3/4"
- 2 x [6023] Roof Side 5/8 x 3-1/4 x 40-1/8"
- 1 x [6029] Side Top 15/16 x 3-1/4 x 30-7/8"
- 1 x [6030] Tunnel Side Top 15/16 x 3-1/4 x 30-7/8"

### Hardware

- 8 x [H2] 1/4 x 2" Hex Bolt (LW1, FW1, TN1)

# Step 40: Lower Frame Assembly Part 1

**A:** Place 1 (6002) Long Post and 1 (6026) Rock Rail side by side with the (6002) Long Post on the left side making sure that the notched out end is at the top and on the inside. It is important to ensure that the angled cut on the (6026) Rock Rail is at the top, facing inwards towards the (6002) Long Post. Place 1 (6020) Short Ground across the bottom of both pieces so that it's flush with the ends of the (6002) Long Post and the (6026) Rock Rail. Attach using 2 (H2) ¼ x 2" Hex Bolts (with lock washer, flat washer and t-nuts). (Fig. 40.2)

**B:** From the underside of the assembly place 1 (6017) Floor Support making sure the pre-drilled holes match what is shown on fig.(Fig. 40.2). Attach using 2 (H3) ¼ x 2-1/2" Hex Bolts (with lock washer, flat washer and t-nuts). (Fig. 40.1 & Fig. 40.2)

Fig. 40.1

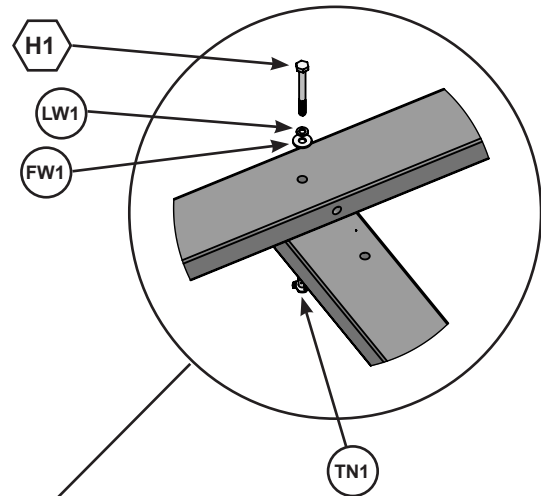
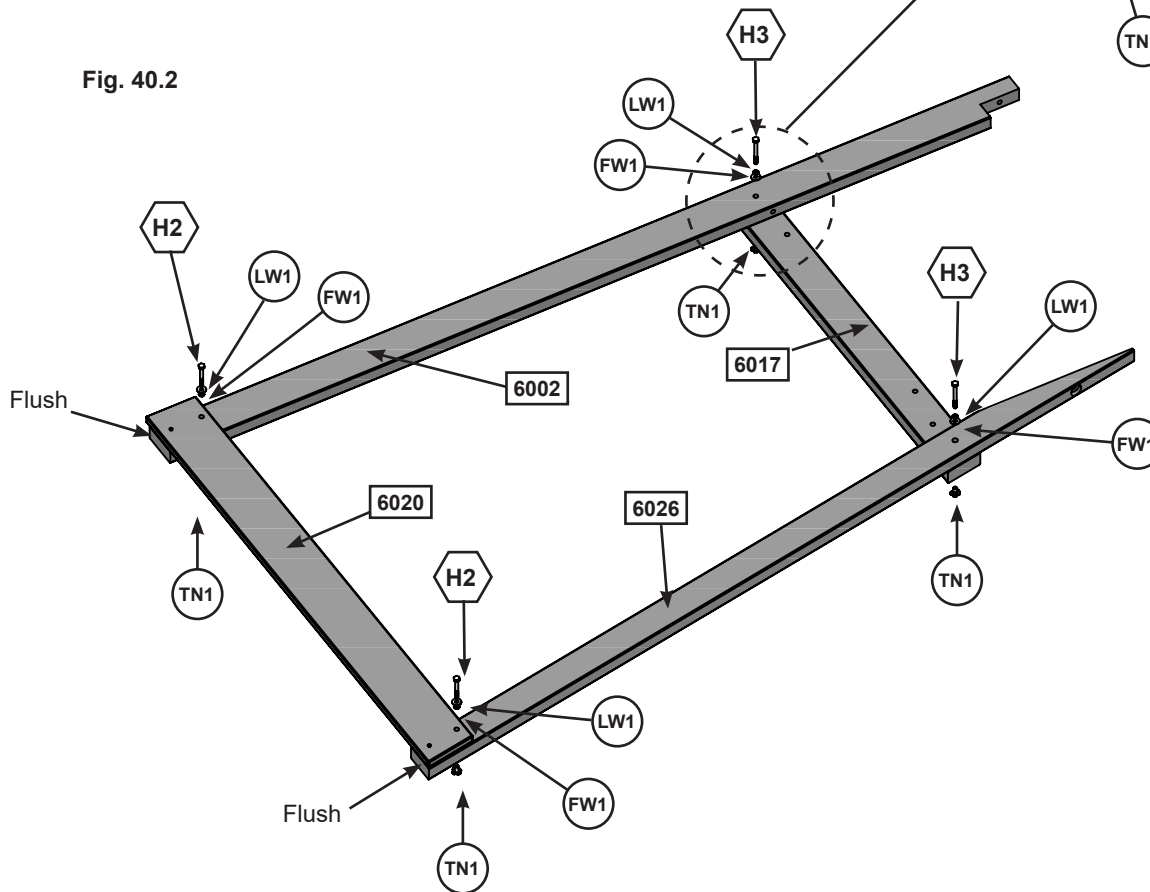


Fig. 40.2



### Wood Parts

- 1 x 6002 Long Post 1-1/4 x 3-1/4 x 77-1/2"
- 1 x 6017 Floor Support 1-1/4 x 3-1/4 x 34-1/2"
- 1 x 6020 Short Ground 5/8 x 4-1/2 x 44-1/8"
- 1 x 6026 Rock Rail 1-1/4 x 2-3/4 x 71-15/16"

### Hardware

- 2 x H2 1/4 x 2" Hex Bolt (LW1, FW1, TN1)
- 2 x H3 ¼ x 2-1/2" Hex Bolts (LW1, FW1, TN1)

# Step 40: Lower Frame Assembly Part 2



**C:** Place 1 (6002) Long Post and 1 (6026) Rock Rail side by side with the (6002) Long Post on the right side, notched end at the top and facing the inside and the (6026) Rock Rail on the left. Make sure that the angled cut on the (6026) Rock Rail is at the top, facing inwards towards the (6002) Long Post. (Fig. 40.3 & 40.5)

**D:** From the underside of the assembly place 1 (6017) Floor Support making sure the pre-drilled holes match what is shown on fig.(Fig. 40.3). Attach using 2 (H3) 1/4 x 2-1/2" Hex Bolts (with lock washer, flat washer and t-nuts). (Fig. 40.3 & 40.4)

**E:** Place 1 (6018) Long Ground across the bottom of both pieces so that it's flush with the ends of the (6002) Long Post and the (6026) Rock Rail. Attach (6018) Long Ground using 2 (H2) 1/4 x 2" Hex Bolts (with lock washer, flat washer and t-nuts). (Fig. 40.3 )

**F:** On the underside of the (6018) Long Ground place 1 (0369) Lower Diagonal tight and flush to the (6002) Long Post and the (6018) Long Ground. Attach through (6018) Long Ground with 2 (H2) 1/4 x 2" Hex Bolts (with lock washer, flat washer and t-nut). Pre-drill upper hole of (0369) Lower Diagonal with a 1/8" (3.2mm) drill bit and install 1 (LS3) 1/4 x 3" Lag Screw (with flat washer). (fig. 40.3)

Fig. 40.3  
left view

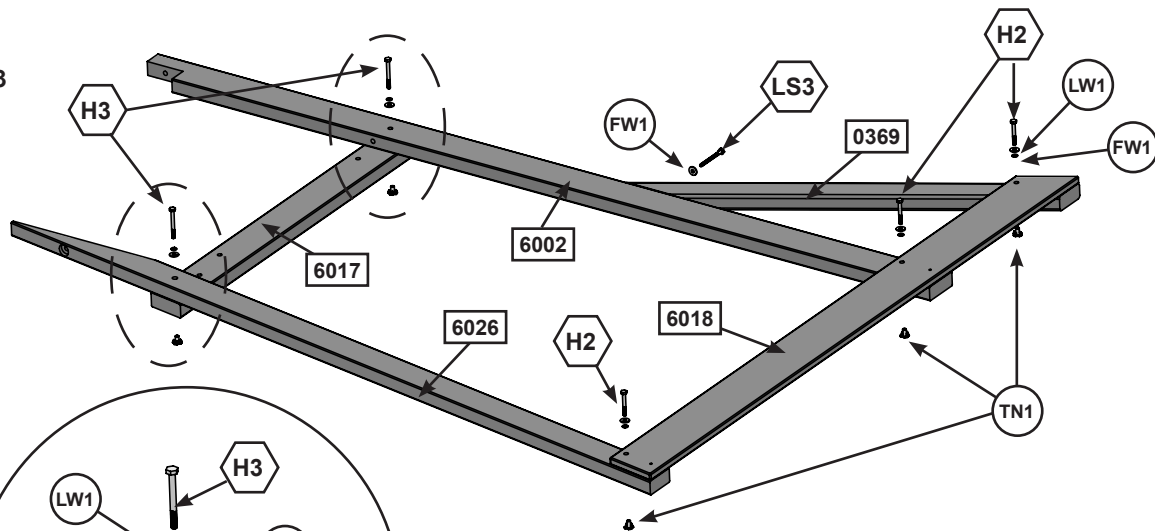


Fig. 40.4

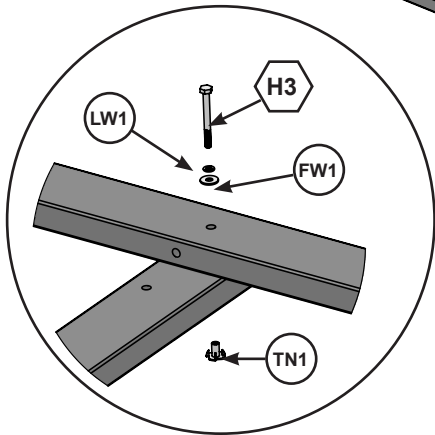
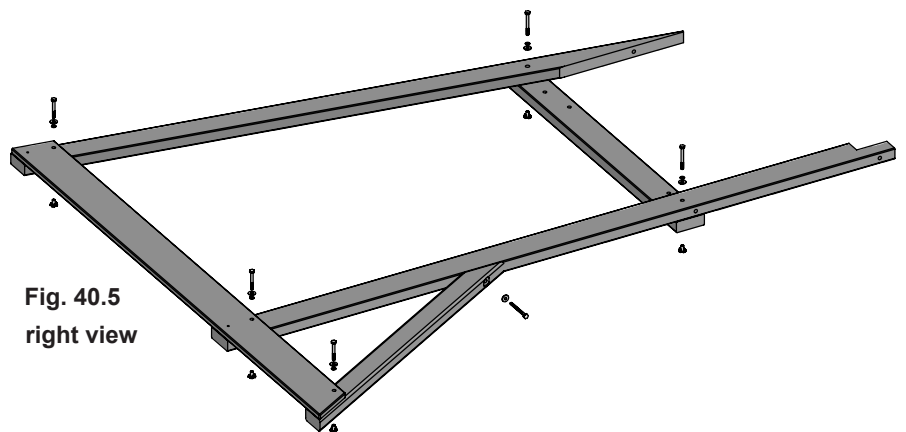


Fig. 40.5  
right view



### Wood Parts

- 1 x **6002** Long Post 1-1/4 x 3-1/4 x 77-1/2"
- 1 x **6017** Floor Support 1-1/4 x 3-1/4 x 34-1/2"
- 1 x **6018** Long Ground 5/8 x 4-1/2 x 62"
- 1 x **6026** Rock Rail 1-1/4 x 2-3/4 x 71-15/16"
- 1 x **0369** Lower Diagonal 1-3/8 x 2-1/2 x 37"

### Hardware

- 3 x **H2** 1/4 x 2" Hex Bolt (LW1, FW1, TN1)
- 2 x **H3** 1/4 x 2-1/2" Hex Bolts (LW1, FW1, TN1)
- 1 x **LS3** 1/4 x 3" Lag Screw (FW1)

# Step 41: Frame Assembly



**A:** Make sure that lower frame assemblies are square then attach 1 (6021) Back Ground to the outside of the (6002) Long Posts using 4 (S11) #8 x 2" Screws (with FW1) making sure that it is flush to the bottom. (Fig. 41.3 & 41.4 )

**B:** Making sure that it's flush to the bottom of the (6020) Short Ground and (6018) Long Ground, attach 1 (6019) Rock Bottom to the Rock Rails using 4 (S20) #8 x 1-3/8" Wood Screws. Make sure that the notch is at the top, left hand side.(Fig. 41.1 )

**C:** Place 1 (6042) Narrow Floor Board on the front end of the (6017) Floor Supports and 1 (6013) Floor Board on far end other as shown in (fig. 41.1) making sure they are flush with the (6002) Long Posts and (6026) Rock Rails. **Do not attach these boards until Step 27.**

**D:** Using the (6042) Narrow Floor Board as a guide, place (0600) Bottom trim flush to the top of the front (6042) Narrow Floor Board and attach to the Rock Rails using 2 (S7) #12 x 2" Pan Screws (with FW1) and 2 (S20) #8 x 1-3/8" Wood Screws.. (Fig. 41.1 )

**E:** On the back side attach 1 (6034) Floor Back to the (6002) Long Posts using 1 (S7) #12 x 2" Pan Screw and 2 (H8) 1/4 x 4-1/4" Hex Bolt (with lock washer, flat washer and t-nut) per side. (Fig. 41.2 & 41.3)

Fig. 41.2

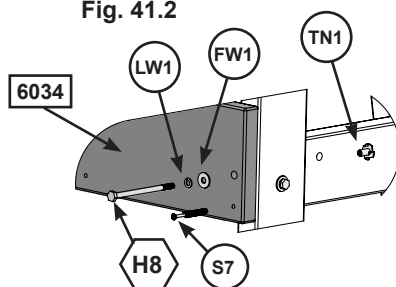


Fig. 41.3

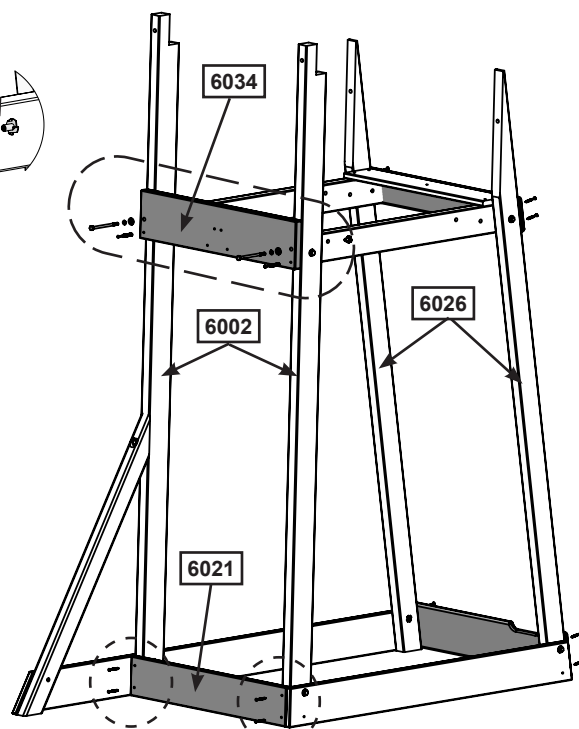


Fig. 41.1

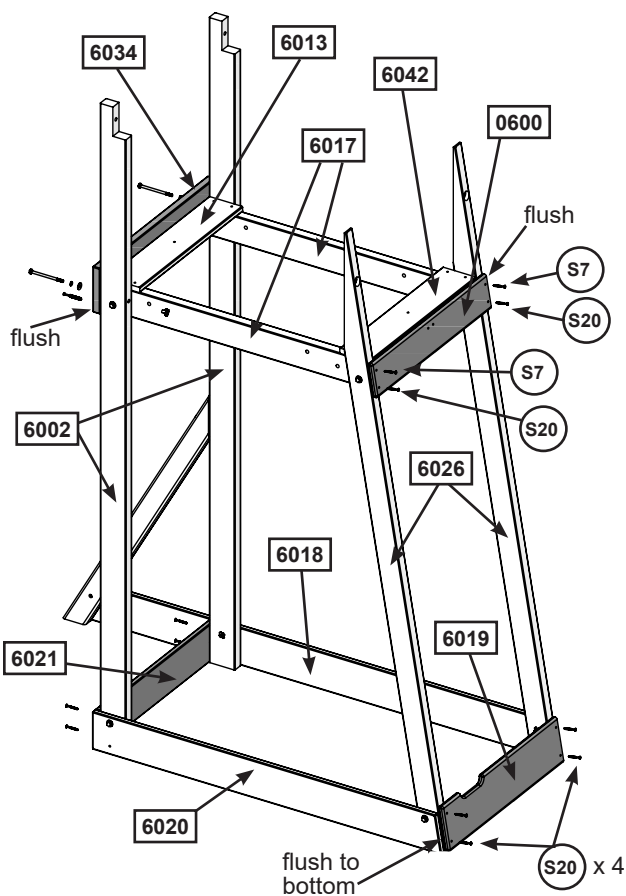
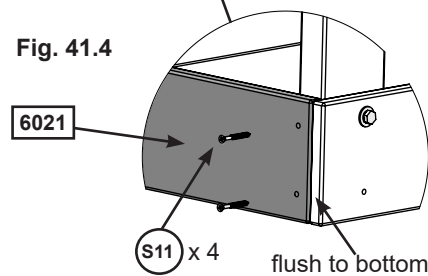


Fig. 41.4



## Wood Parts

- 1 x 6021 Back Ground 5/8 x 4-1/2 x 23-1/2"
- 1 x 6019 Rock Bottom 5/8 x 5-1/4 x 23-1/2"
- 1 x 6013 Floor Board 5/8 x 4-1/4 x 21"
- 1 x 0600 Bottom Trim 5/8 x 4 x 23-1/2"
- 1 x 6034 Floor Back 15/16 x 5-1/2 x 23-1/2"
- 1 x 6042 Narrow Floor Back 5/8 x 3-14/16 x 21"

## Hardware

- 4 x S11 #8 x 2" Screws
- 6 x S20 #8 x 1-3/8" Wood Screws
- 2 x H8 1/4 x 4-1/4" Hex Bolt (LW1, FW1, TN1)
- 4 x S7 #12 x 2" Pan Screw

# Step 42: Floor Assembly

**A:** Place (6003) Floor Joist flush to the underside of the (6013) Floor Board and centred over the pilot holes in the (6034) Floor Back and (0600) Bottom Trim. The angle cut should be flush with the (0600) Bottom trim (Fig. 42.1 and 42.2 and 42.3). Attach using 2 (S11) #8 x 2" Wood Screws per side. (Fig. 42.1 and 42.2 and 42.3)

**B:** Evenly Space the remaining (6013) floor boards and attach each board using 5 (S20) #8 x 1-3/8" Wood Screws per board.(Fig. 42.4 and 42.5).

Fig. 42.1

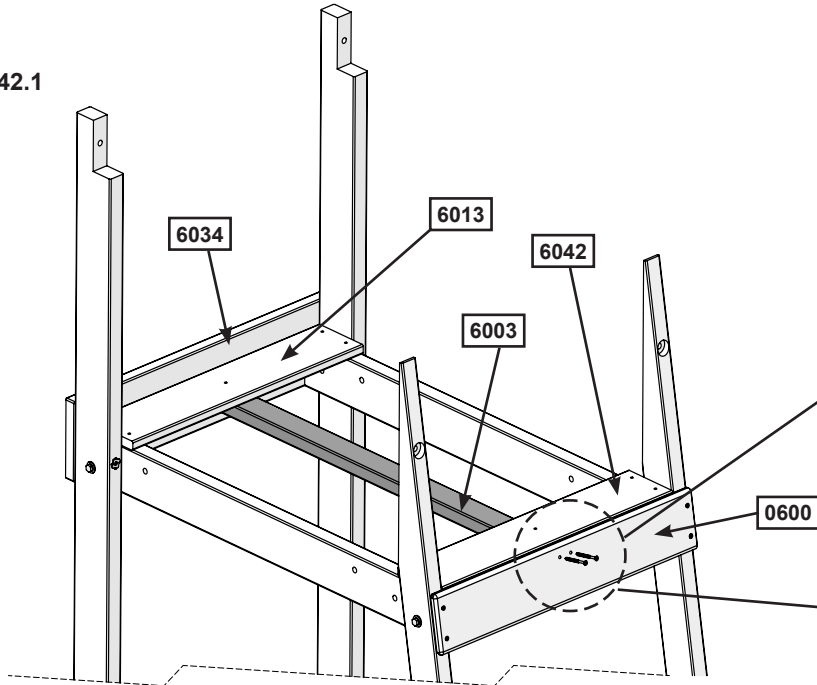


Fig. 42.2

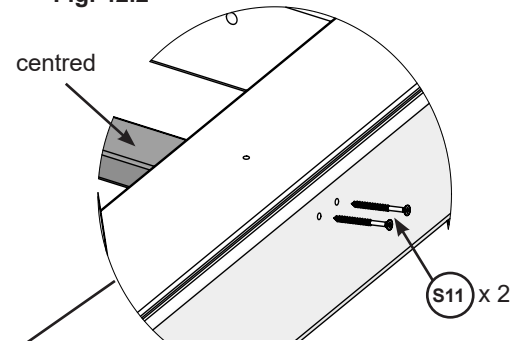


Fig. 42.3

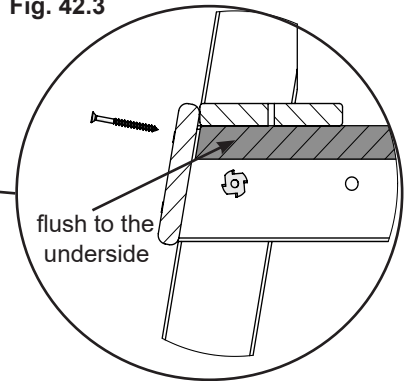


Fig. 42.4

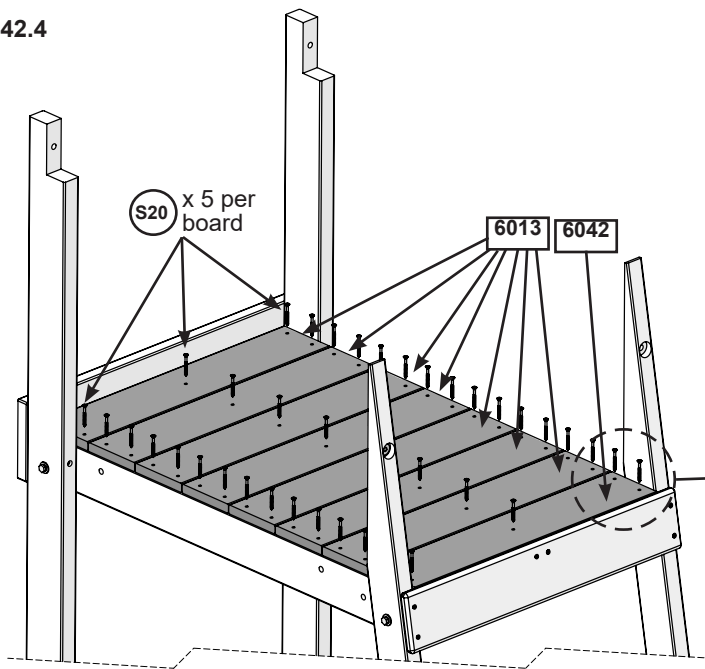
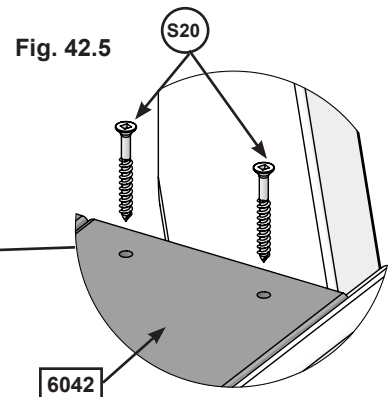


Fig. 42.5



## Wood Parts

- 1 x 6003 Floor Joist 15/16 x 2 x 33-15/16"
- 6 x 6013 Floor Board 5/8 x 4-1/4 x 21"

## Hardware

- 4 x S11 #8 x 2" Wood Screws
- 40 x S20 #8 x 1-3/8" Wood Screws

# Step 43: Climbing Wall Assembly

**A:** Starting with a (6009) Rock Board B at both the top and bottom of the Climbing Wall, alternate between (6010) Rock Boards A and (6009) Rock Boards B making sure that the boards are evenly spaced as shown in (fig. 43.1). Attach using 4 (S20) #8 x 1-3/8" Wood Screws per board. (Fig. 43.1 & 43.2)

**Note:** Board orientation must be followed closely.

Fig. 43.1

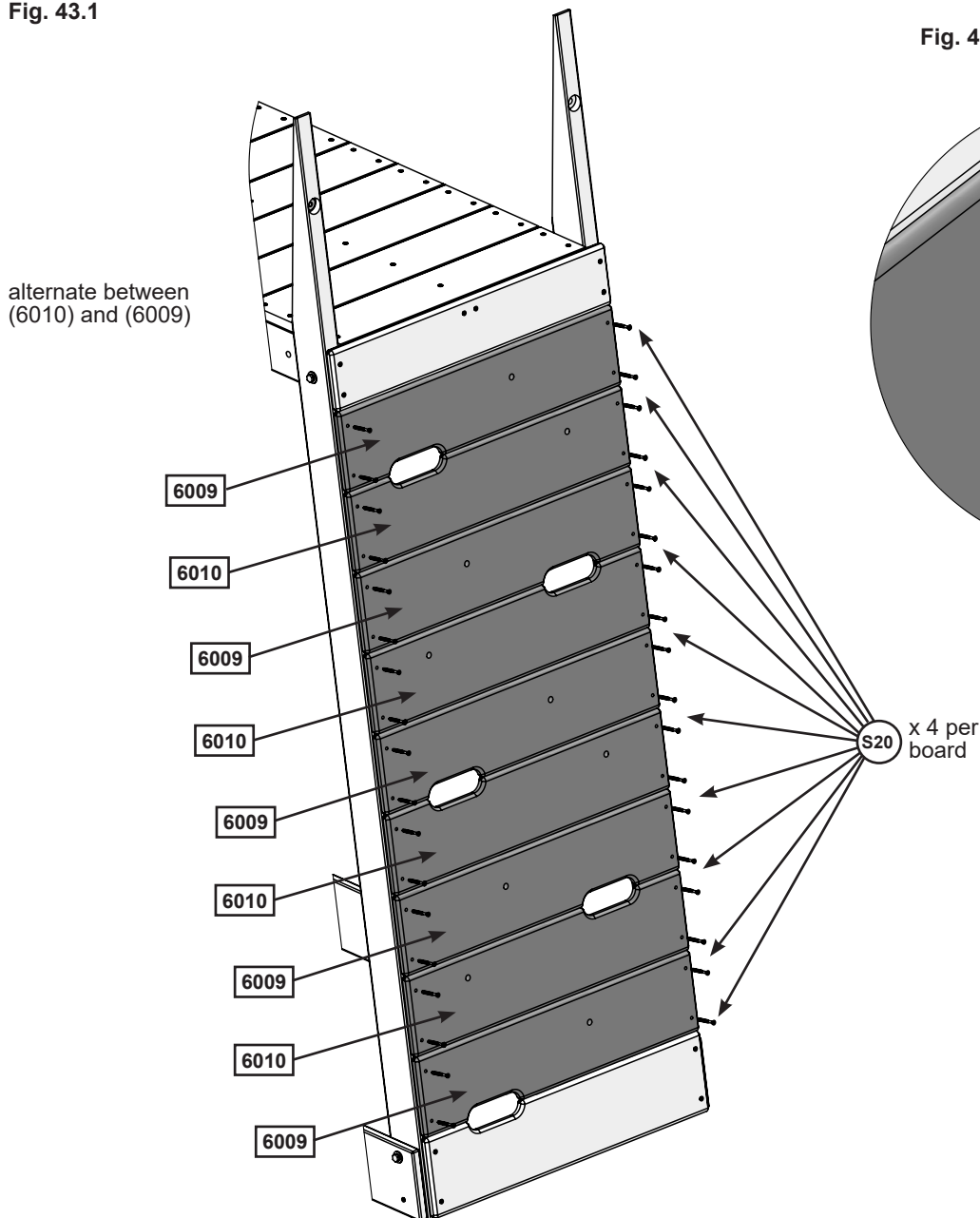
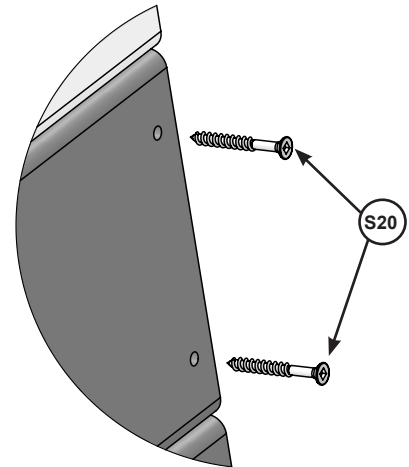


Fig. 43.2



## Wood Parts

- 5 x 6009 Rock Board B 5/8 x 5-1/4 x 23-1/2"
- 4 x 6010 Rock Board A 5/8 x 5-1/4 x 23-1/2"

## Hardware

- 36 x S20 #8 x 1-3/8" Wood Screws

# Step 44: Wall Top Assembly Part 1



**A:** Making sure that assemblies are square, position the Left Wall Assembly onto the lower left assembly as shown in (fig. 44.1 & 44.2). Attach (6002) Long Post to (6012) Short Post using 1 (H12) 1/4 x 3" Hex Bolt (with lock washer, flat washer and t-nut). In the upper hole of (6026) Rock Rail, pre-drill with a 1/8" (3.2mm) drill bit and install 1 (LS3) 1/4 x 3" Lag Bolt (with flat washer). Install 1 (H3) 1/4 x 2-1/2" Hex Bolt (with flat washer, lock washer and t-nut) in the (6000) Upper Post. (fig. 44.1 & 44.2)

Fig. 44.1

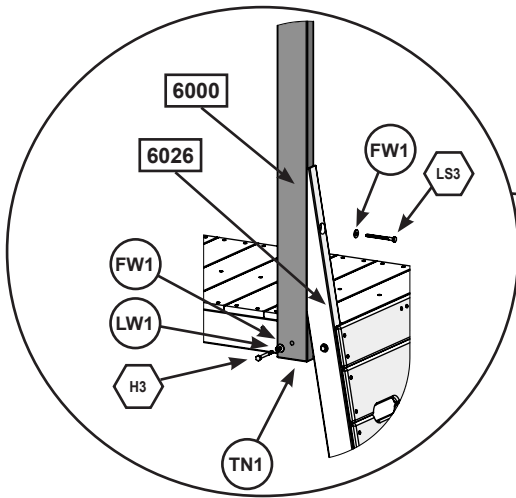
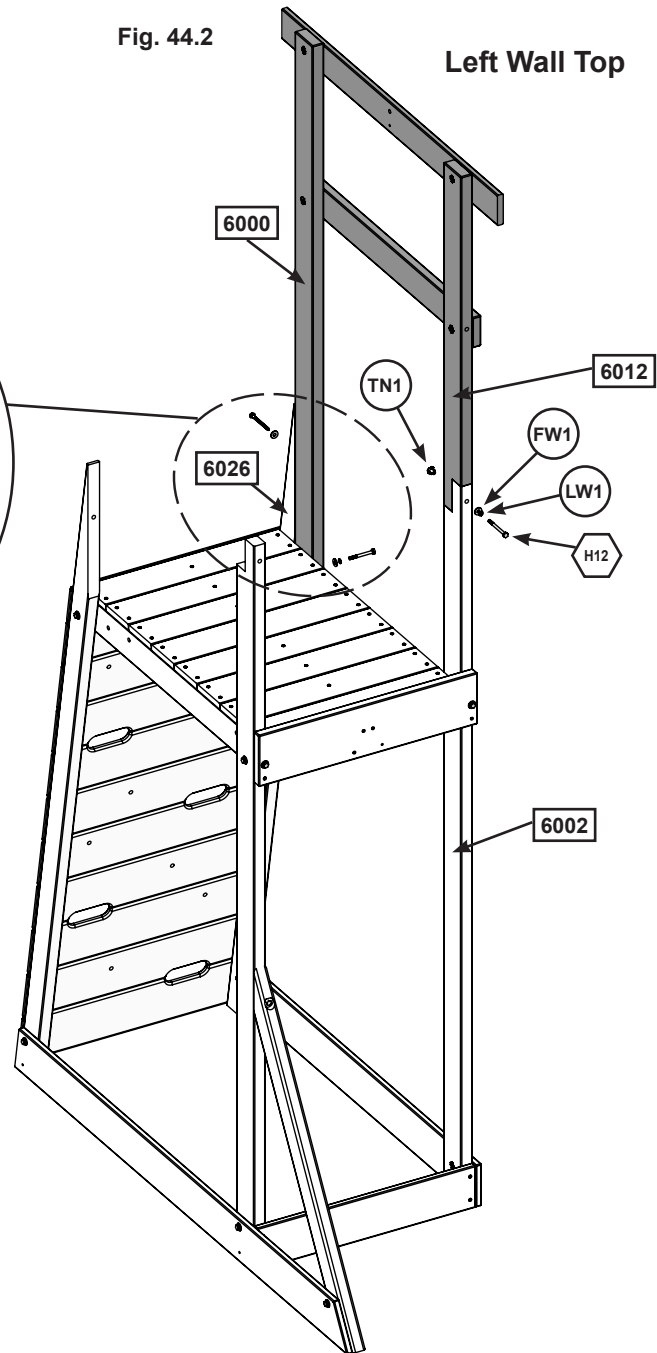


Fig. 44.2



### Hardware

- 1 x  1/4 x 3" Hex Bolt (LW1, FW1, TN1)
- 1 x  1/4 x 3" Lag Bolt (FW1)
- 1 x  1/4 x 2-1/2" Hex Bolt (LW1, FW1, TN1)

# Step 44: Wall Top Assembly Part 2



B: Repeat step A to install the Right Wall Assembly. (fig. 44.3 & 44.4)

*Before proceeding to the next step ensure that unit is completely square and all hardware is tightened.*

Fig. 44.3

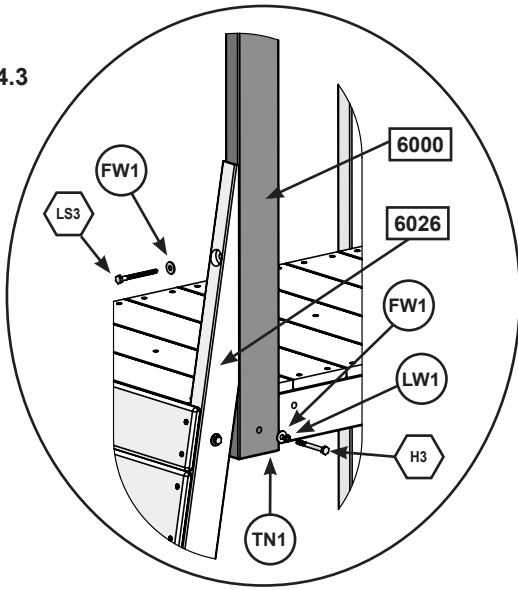
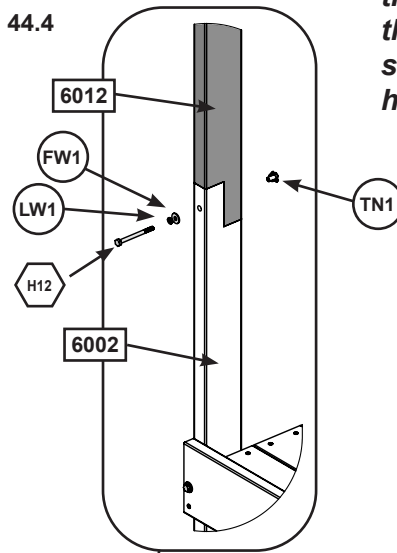
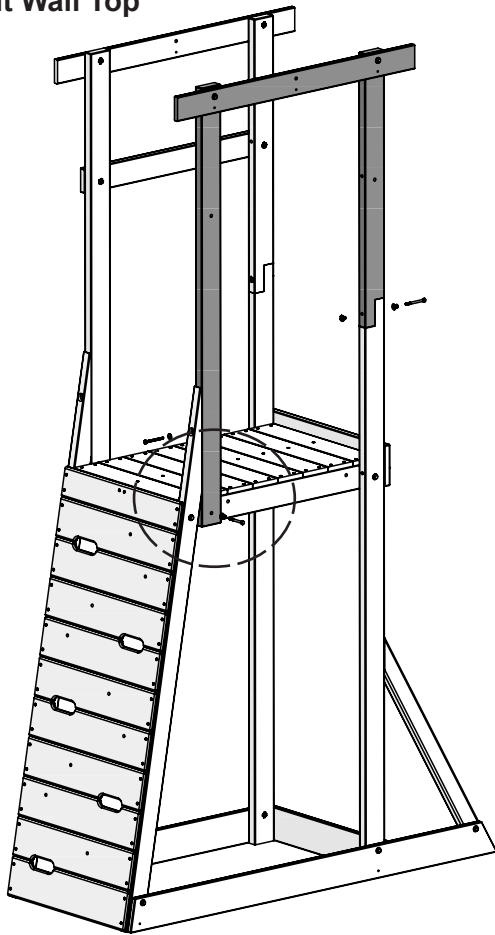


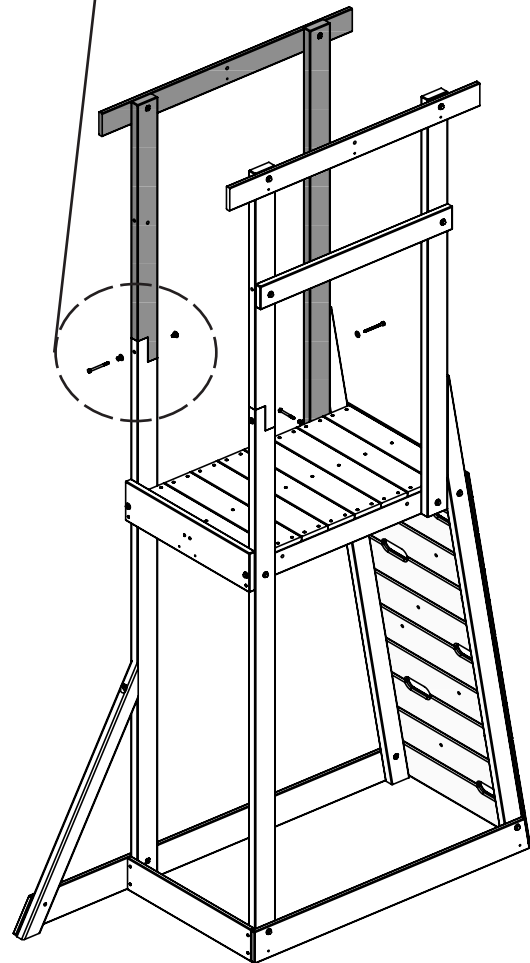
Fig. 44.4



Right Wall Top



Right Wall Top



### Hardware

- 1 x  1/4 x 3" Hex Bolt (LW1, FW1, TN1)
- 1 x  1/4 x 3" Lag Bolt (FW1)
- 1 x  1/4 x 2-1/2" Hex Bolt (LW1, FW1, TN1)



# Step 45: Install Top Back

- A:** On the back side of the assembly install (6028) Top Back using 2 (H8)  $\frac{1}{4}$  x 4-1/4" Hex Bolt (with flat washer, lock washer and t-nut) in the upper hole and 2 (S7) #12 x 2" Pan Screws in the bottom holes. (fig 45.1 & 45.3)
- B:** On the left and right Roof Sides install 2 (S20) #8 x 1-3/8" Wood Screws into the bottom holes. (fig 45.1 & 45.2)
- C:** Install 1 (S20) #8 x 1-3/8" Wood Screw into each pre-drilled hole on the bottom of the (6020) Short Ground and (6018) Long Ground as shown in (fig. 45.1 & 45.4).

Fig. 45.2

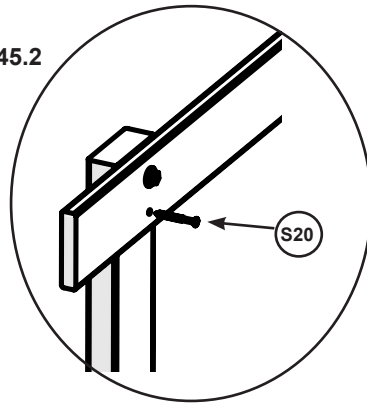


Fig. 45.1

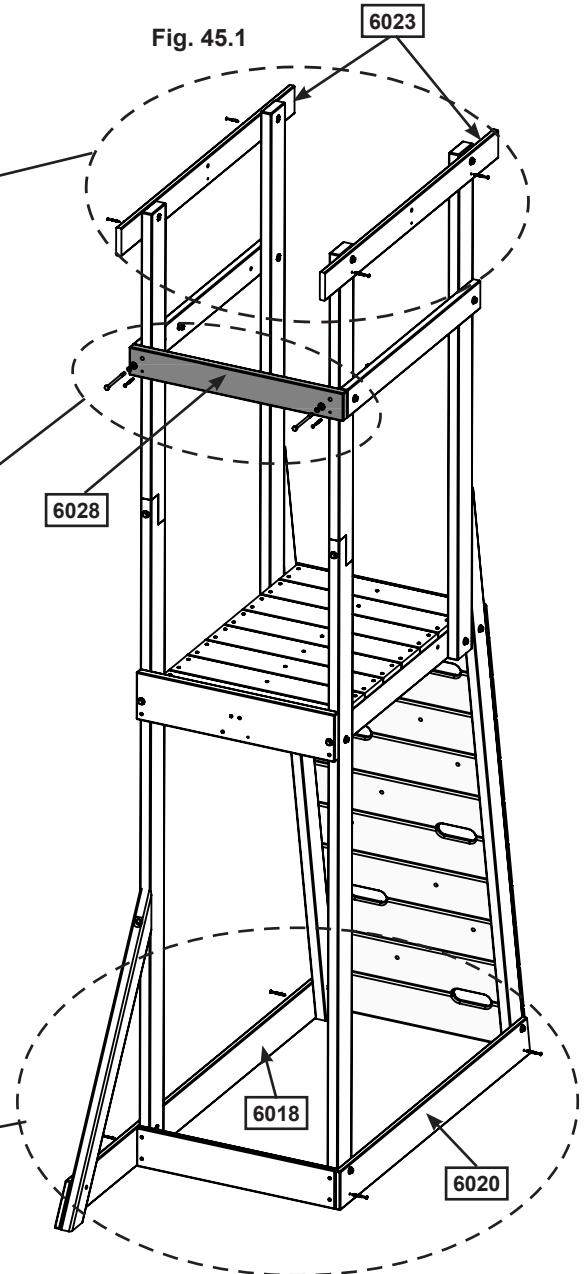


Fig. 45.3

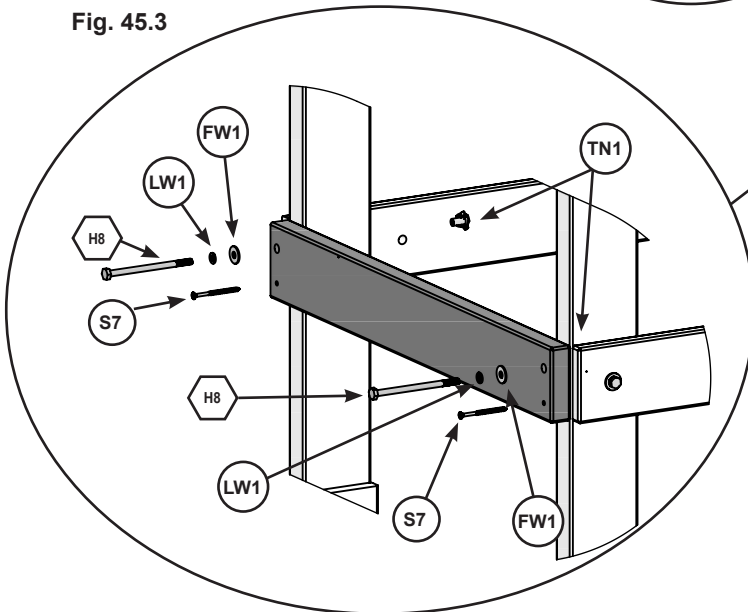
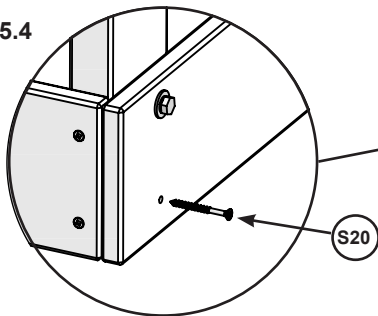


Fig. 45.4



### Wood Parts

1 x 6028 Top Back 15/16 x 3-1/4 x 25-3/8"

### Hardware

- 8 x S20 #8 x 1-3/8" Wood Screws
- 2 x S7 #12 x 2" Pan Screws
- 2 x H8  $\frac{1}{4}$  x 4-1/4" Hex Bolt (LW1, FW1, TN1)

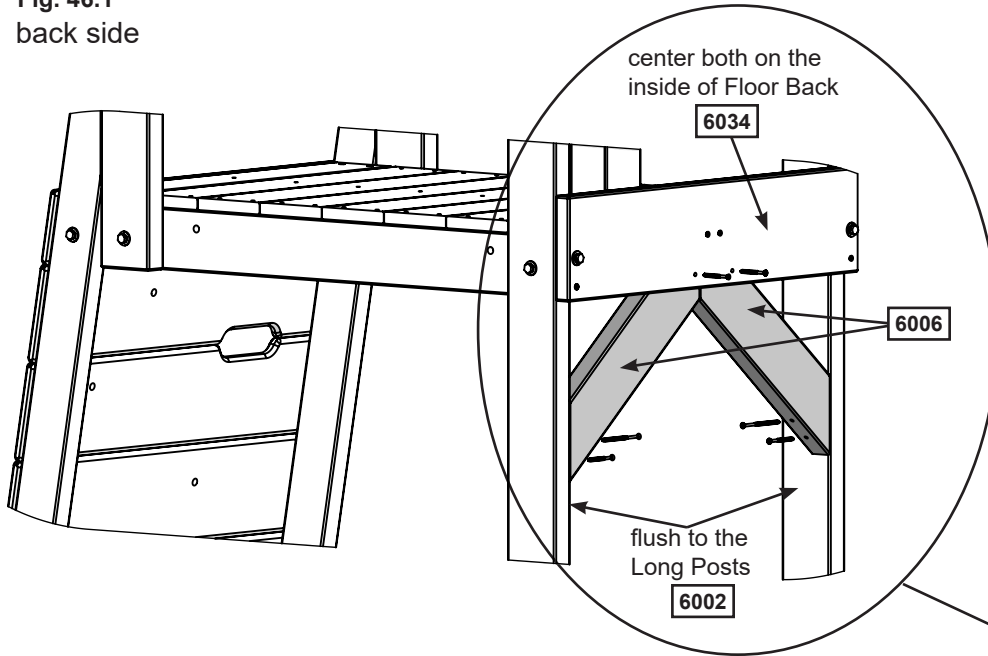
# Step 46: Install Gussets

## Part 1

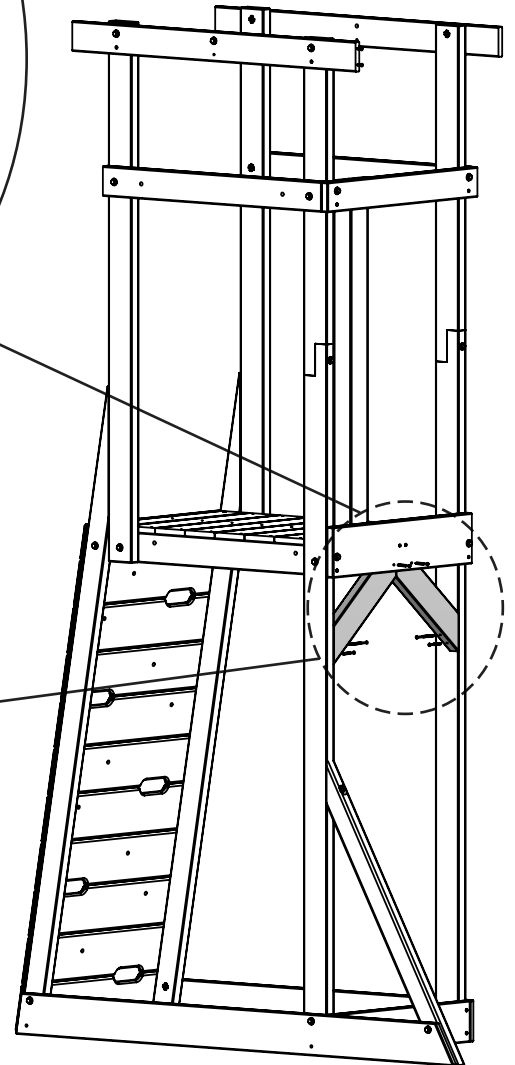
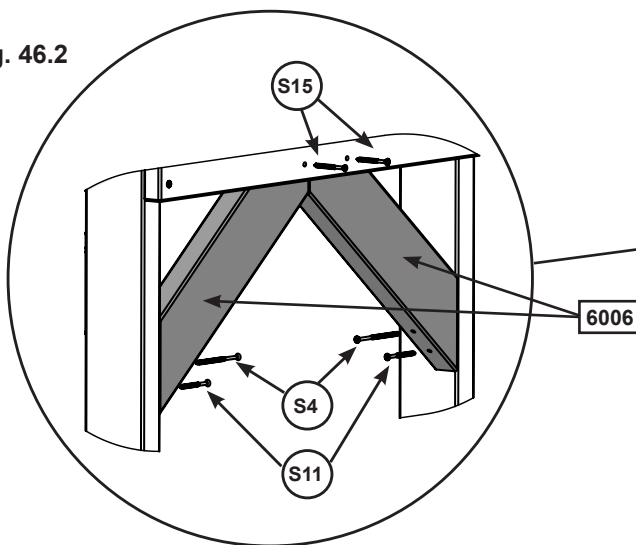
**A:** On the back side of the assembly place 2 (6006) Back Gussets so they meet tightly together to form a point. Center the (6006) Back Gussets on the inside of the (6034) Floor Back making sure the other ends are flush to the Long Posts. (Fig.46.1)

**B:** From the outside, attach the (6006) Back Gussets at the top using 2 (S15) #8 x 1-3/4" Wood Screws. Attach the (6006) Back Gussets to the (6002) Long Posts using 1 (S4) #8 x 3" Wood Screw per side in the upper hole and 1 (S11) #8 x 2" Wood Screw per side in the bottom holes. (Fig.46.2)

**Fig. 46.1**  
back side



**Fig. 46.2**



### Wood Parts

2 x **6006** Back Gusset 1-1/4 x 3-1/4 x 15-5/8"

### Hardware

2 x **S4** #8 x 3" Wood Screw

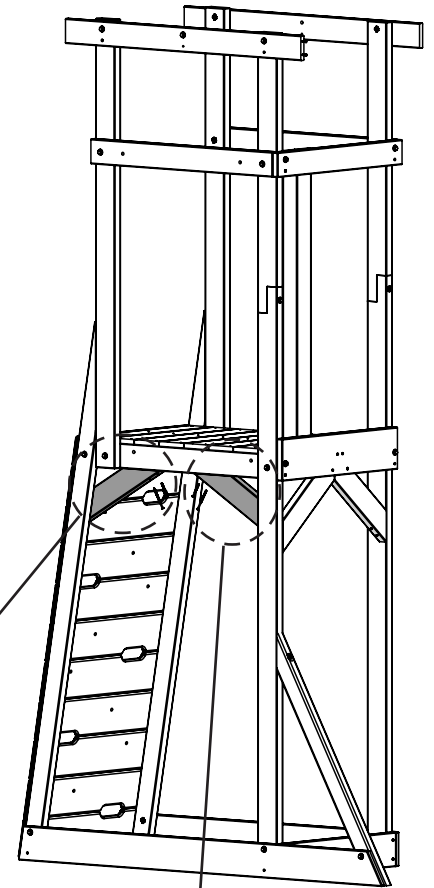
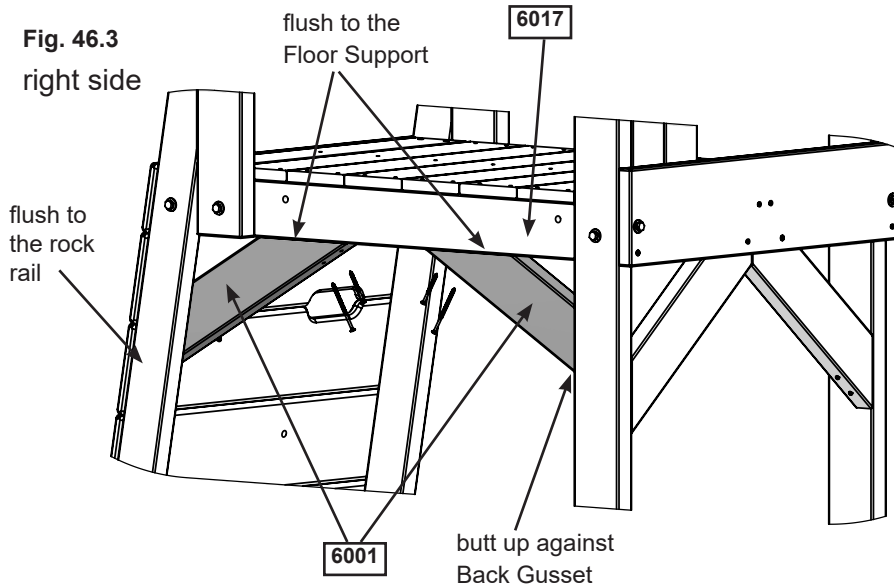
2 x **S11** #8 x 2" Wood Screw

2 x **S15** #8 x 1-3/4" Wood Screws

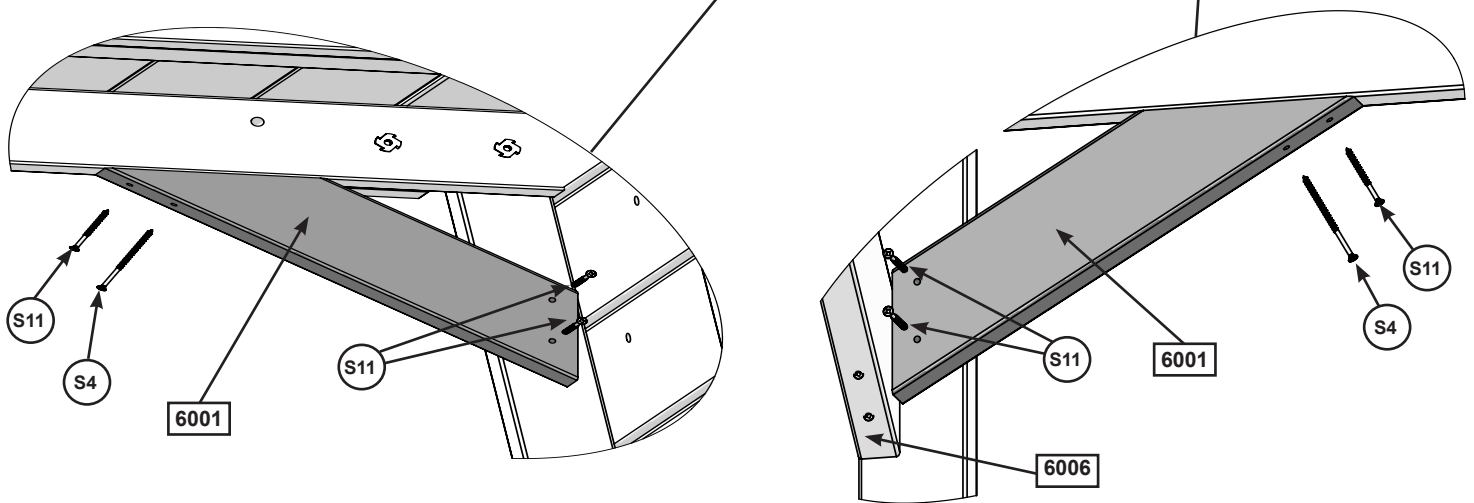
# Step 46: Install Gussets Part 2

**C:** On the right side of the assembly place 2 (6001) Gussets so that they are flush to the (6017) Floor Support. The upper corner of the front (6001) Gusset should be flush to back of the wall boards while the other (6001) Gusset should butt up against the (6006) Back Gusset previously installed. Install (6001) Gussets using 6 (S11) #8 x 2" Wood Screws and 2 (S4) #8 x 3" Wood Screws. (Fig.46.3 & 46.4 )

**Fig. 46.3**  
right side



**Fig. 46.4** view from underneath



## Wood Parts

2 x 6001 Gusset 1-1/4 x 3-1/4 x 16"

## Hardware

2 x S4 #8 x 3" Wood Screw

6 x S11 #8 x 2" Wood Screw

# Step 47: Attach Tarp Frame Part 1



**A:** Place 1 (6024) Tarp End on either side of the (6023) Roof Sides as shown in (Fig. 47.1 & 47.2). Pre-drill with a 1/8" (3.2mm) drill bit and attach from the outside using 4 (S20) #8 x 1-3/8" Wood Screws per side.

**B:** On each inside corner attach a Corner Bracket to the (6024) Tarp Ends and (6023) Roof Sides using 3 (S37) #7 x 5/8" Pan Screws per bracket. (Fig. 47.1 & 47.2)

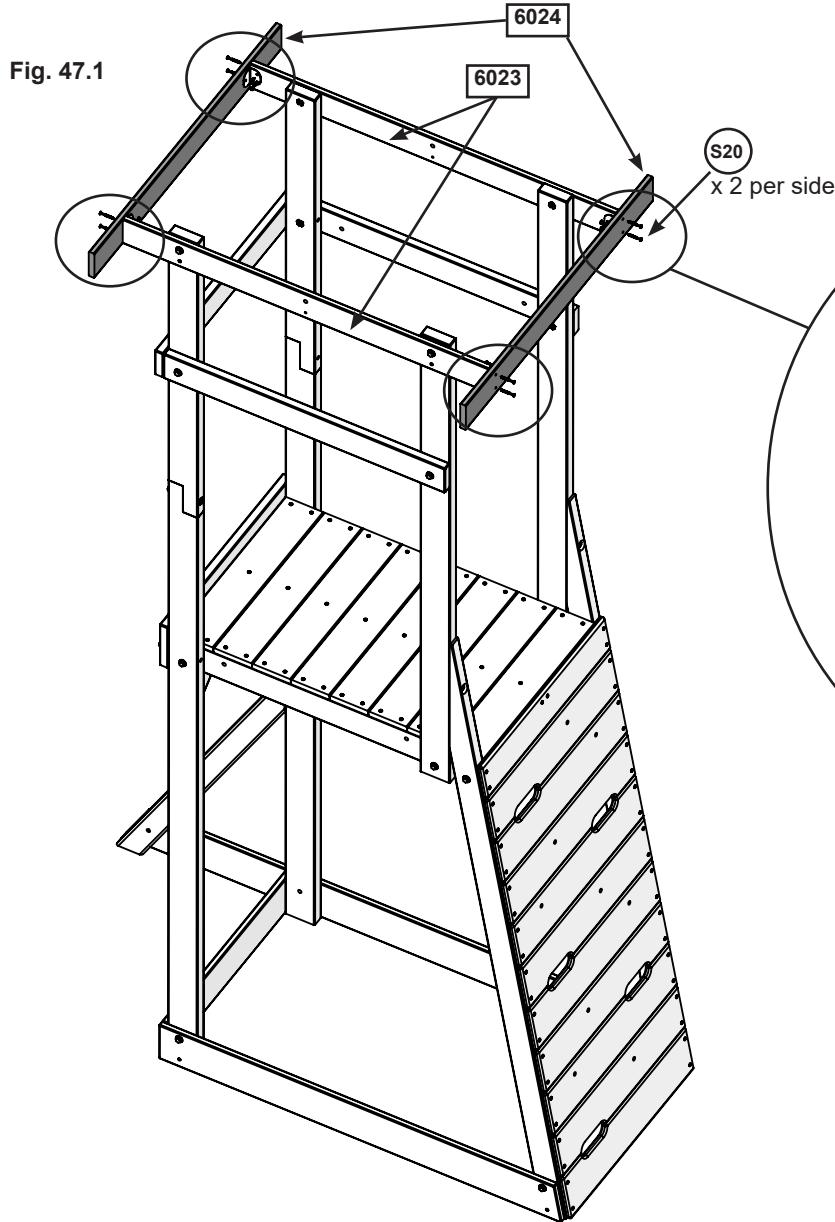
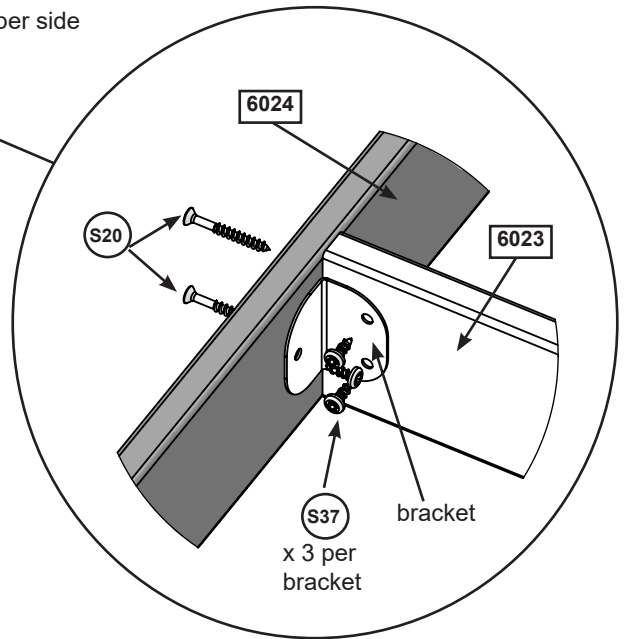


Fig. 47.2



### Wood Parts

2 x 6024 Tarp End 5/8 x 3-1/4 x 35-1/2"

### Hardware

12 x S37 #7 x 5/8" Pan Screws

8 x S20 #8 x 1-3/8" Wood Screws

### Other Parts

4 x Corner bracket

# Step 47: Attach Tarp Frame Part 2

**C:** From inside the assembly using the center holes on the (6023) Roof Sides attach 1 (6008) Tarp Upright per side with 1 (H2) ¼ x 2" Hex Bolt (with flat washer, lock washer and t-nut) per side in the upper holes and 1 (S15) #8 x 1-3/4" Wood Screw per side in the bottom holes. (Fig. 47.3 & 47.4)

**D:** On the top of the (6008) Tarp Uprights install 1 (6025) Tarp Support with 2 (S4) #8 x 3" Wood Screws. (Fig. 47.3 & 47.4)

Fig. 47.3

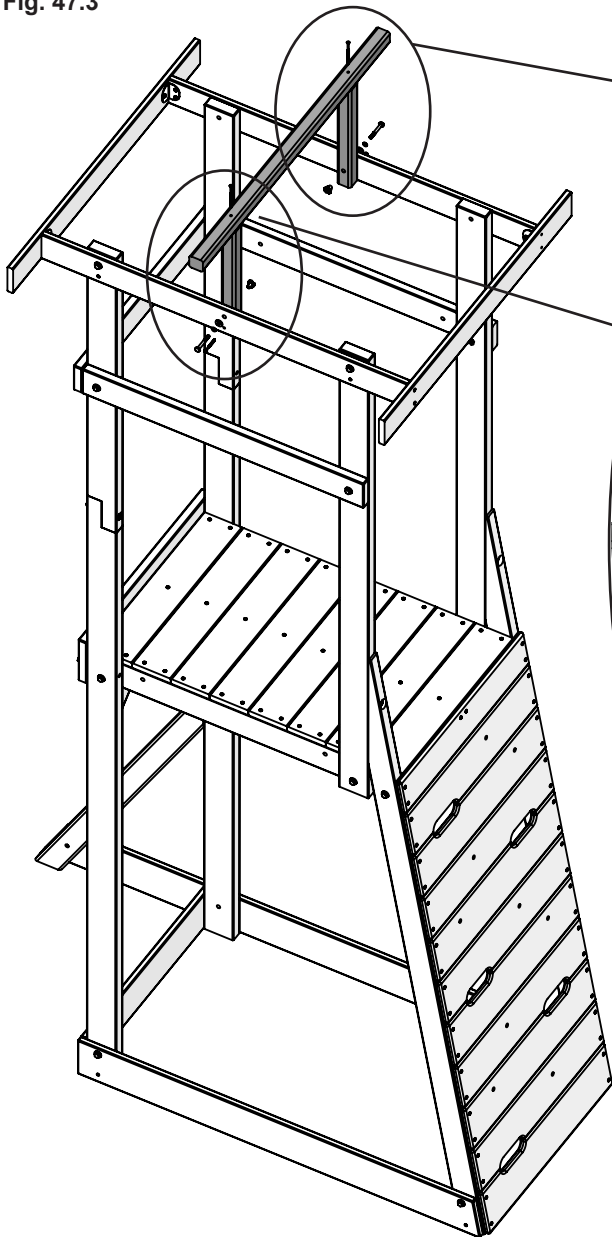
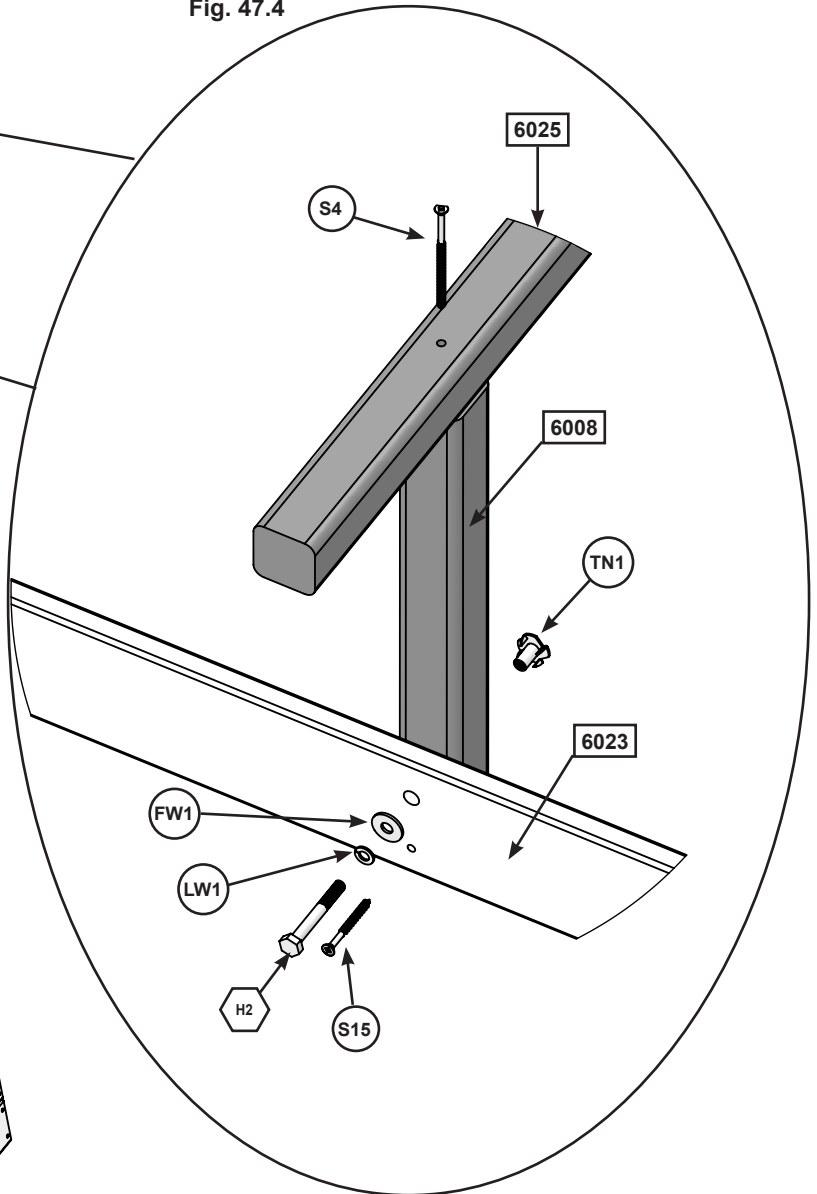


Fig. 47.4



### Wood Parts

- 1 x **6025** Tarp Support 1-1/2 x 1-1/2 x 35-1/2"
- 2 x **6008** Tarp Upright 1-1/2 x 1-1/2 x 13-1/4"

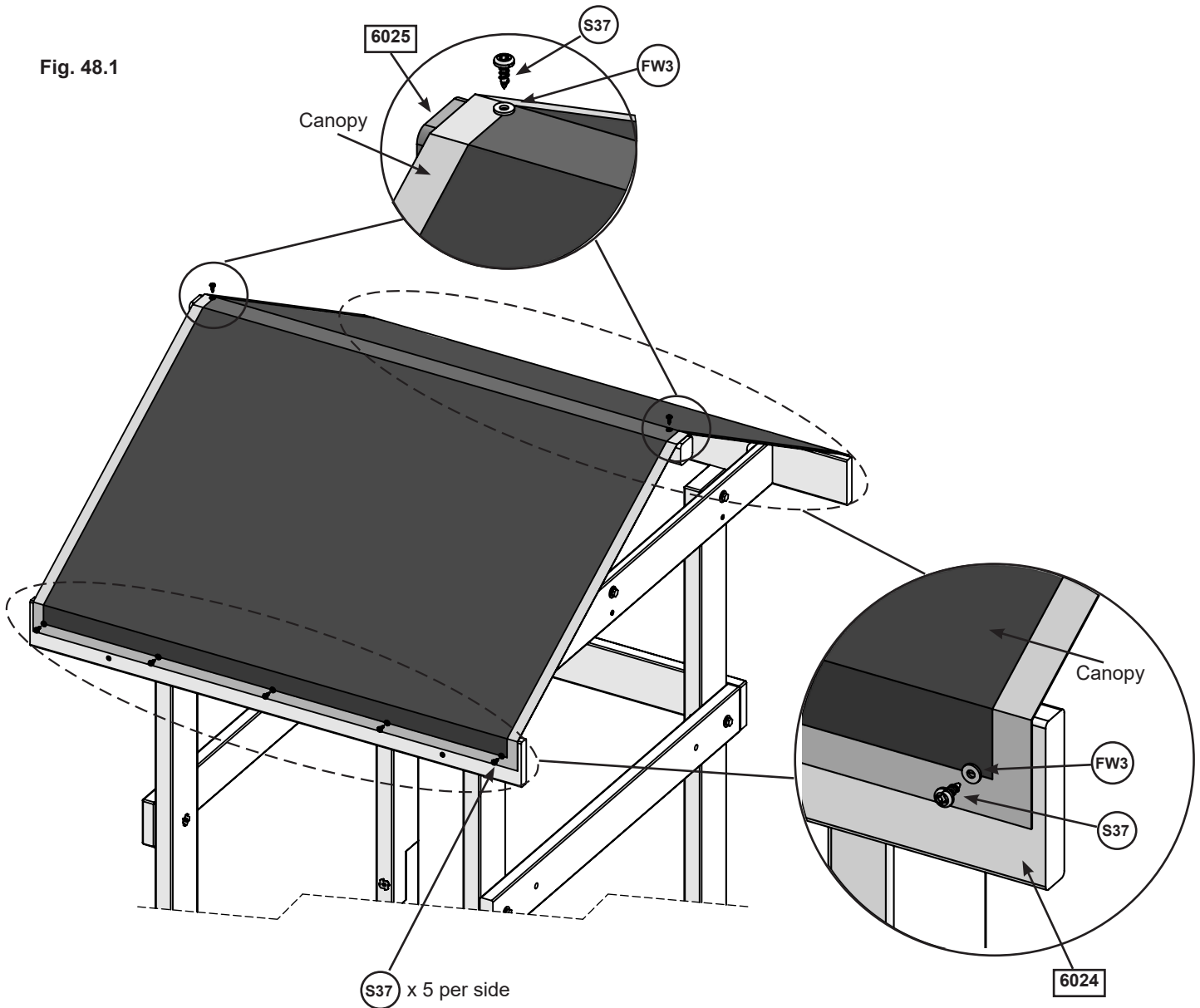
### Hardware

- 2 x **H2** ¼ x 2" Hex Bolt (LW1, FW1, TN1)
- 2 x **S15** #8 x 1-3/4" Wood Screw Screws
- 2 x **S4** #8 x 3" Wood Screw

## Step 48: Attach Tower Canopy

- A:** Place Tower Canopy over (6025) Tarp Support making sure bottom edges of Tower Canopy are even on both sides of assembly.(Fig. 48.1)
- B:** Secure one side by attaching Tower Canopy to 1 (6024) Tarp End using 5 (S37) #7 x 5/8" Pan Screws (with #8 flat washer). (Fig. 48.1)
- C:** Make sure the Tower Canopy is smooth and tight and then secure to the remaining (6024) Tarp End using 5 (S37) #7 x 5/8" Pan Screws (with #8 flat washer). (Fig. 48.1)
- D:** Attach Tower Canopy to each end of the (6025) Tarp Support using 2 (S37) #7 x 5/8" Pan Screws (with #8 flat washer).(Fig. 48.1)

Fig. 48.1



### Hardware

12 x (S37) #7 x 5/8" Pan Screws (FW3)

### Other Parts

1 x Tower Canopy

# Step 49: Install Flags

**A:** On each end of the (6025) Tarp Support center 1 Flag and attach using 2 (S10) #8 x 1" Pan Screws per side. (Fig. 49.1 & 49. 2)

Fig. 49.1

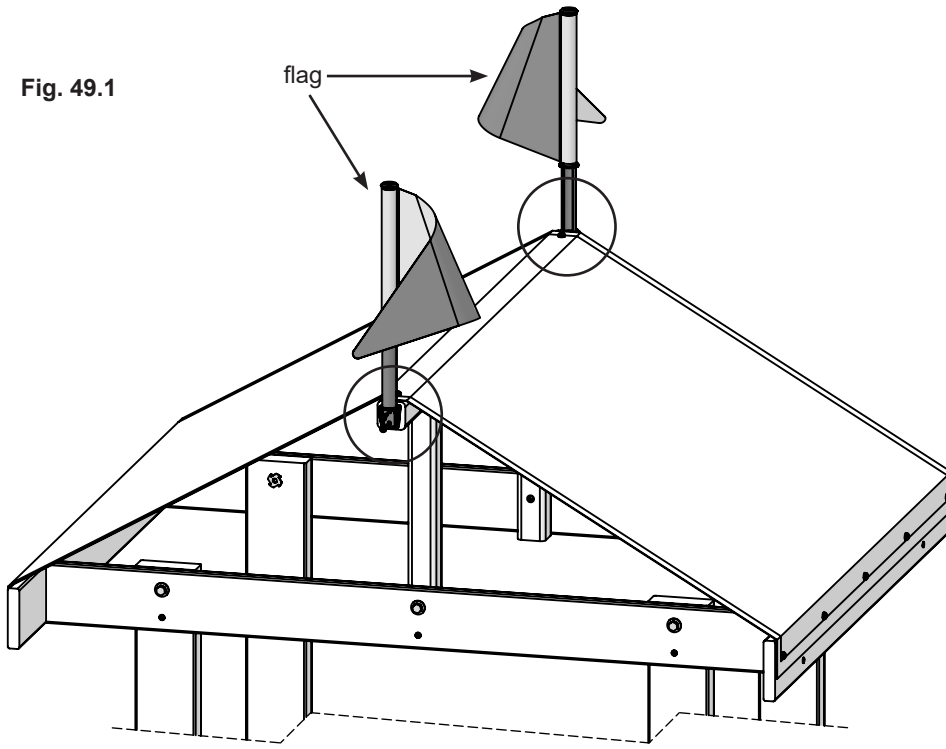
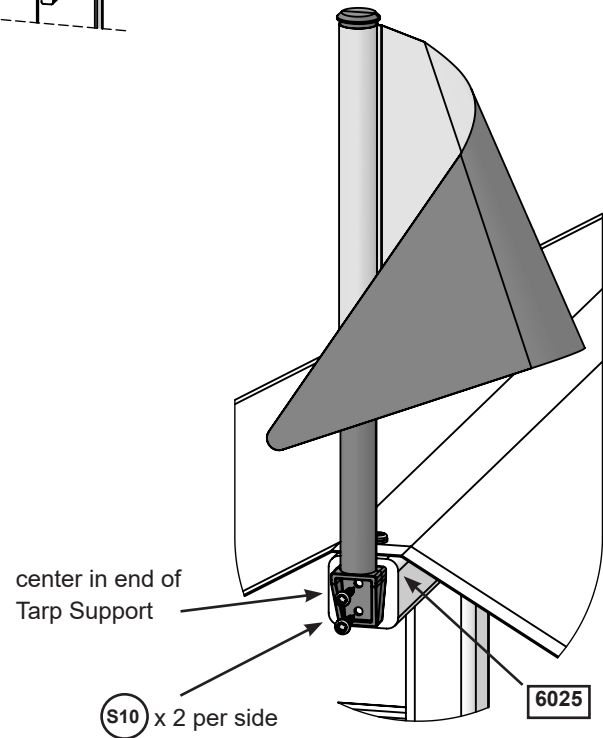


Fig. 49.2



## Hardware

4 x (S10) #8 x 1" Pan Screws

## Other Parts

2 x Flag and Pole

# Step 50: Attach Trim

**A:** Flush to the (0600) Bottom Trim and to the outside edge of the (6026) Rock Rail attach 1 (0602) Short Trim on each side of the (6026) Rock Rails with 1 (S20) #8 x 1-3/8" Wood Screw per side in the center hole. (Fig. 50.1 & 50.2)

**B:** Flush to the top of both (0602) Short Trims attach 1 (0601) Side Trim with 4 (S20) #8 x 1-3/8" Wood Screws per side. (Fig. 50.1 & 50.2)

**C:** Making sure that it's flush with the top of (6030) Tunnel Side Top and both (0601) Side Trims attach 1 (0603) Top trim to the (6000) Upper Posts using 4 (S20) #8 x 1-3/8" Wood Screws. (Fig. 50.1 & 50.2)

Fig. 50.1

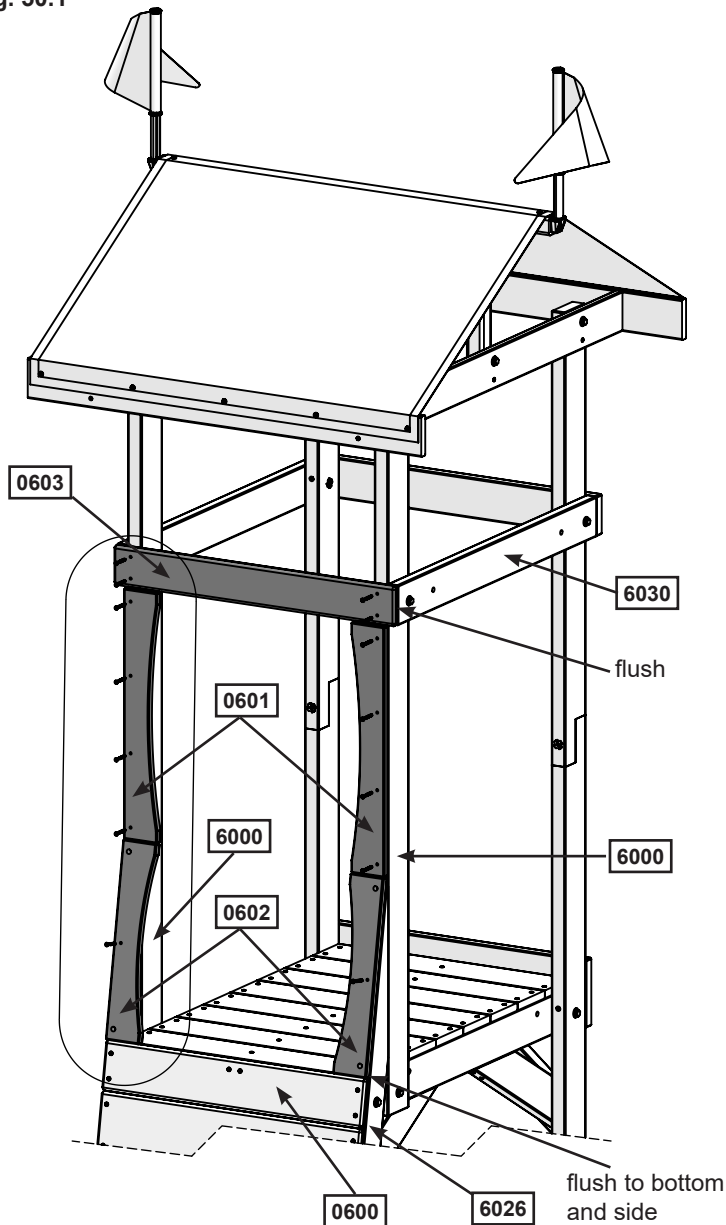
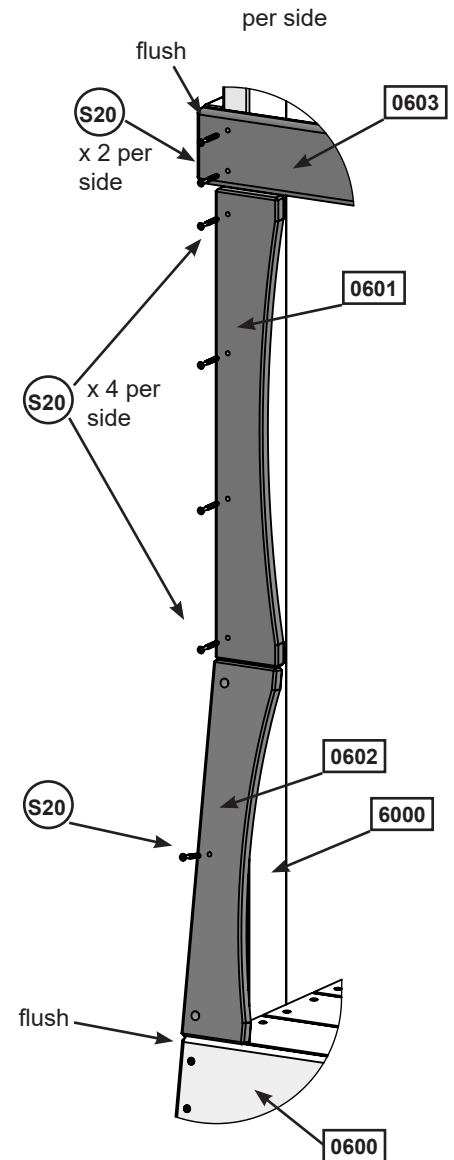


Fig. 50.2



## Wood Parts

- 1 x 0603 Top Trim 5/8 x 3-1/4 x 25-3/8"
- 2 x 0601 Side Trim 5/8 x 3 x 19-5/8"
- 2 x 0602 Short Trim 5/8 x 3 x 16-1/2"

## Hardware

- 14 x (S20) #8 x 1-3/8" Wood Screws



# Step 51: Attach Hand Grips



**A:** Place 1 Hand Grip over the existing holes in (0602) Short Side Trim, making sure that it's centered and flush to the edges. Pre-drill with a 1/8: (3.2mm) drill bit and attach Hand Grip with 2 (LS2) 1/4 x 2-1/2" Lag Screws (with flat washers). (fig. 51.1 and 51.2)

**B:** Repeat step to install a second Hand Grip on the other side.

Fig. 51.1

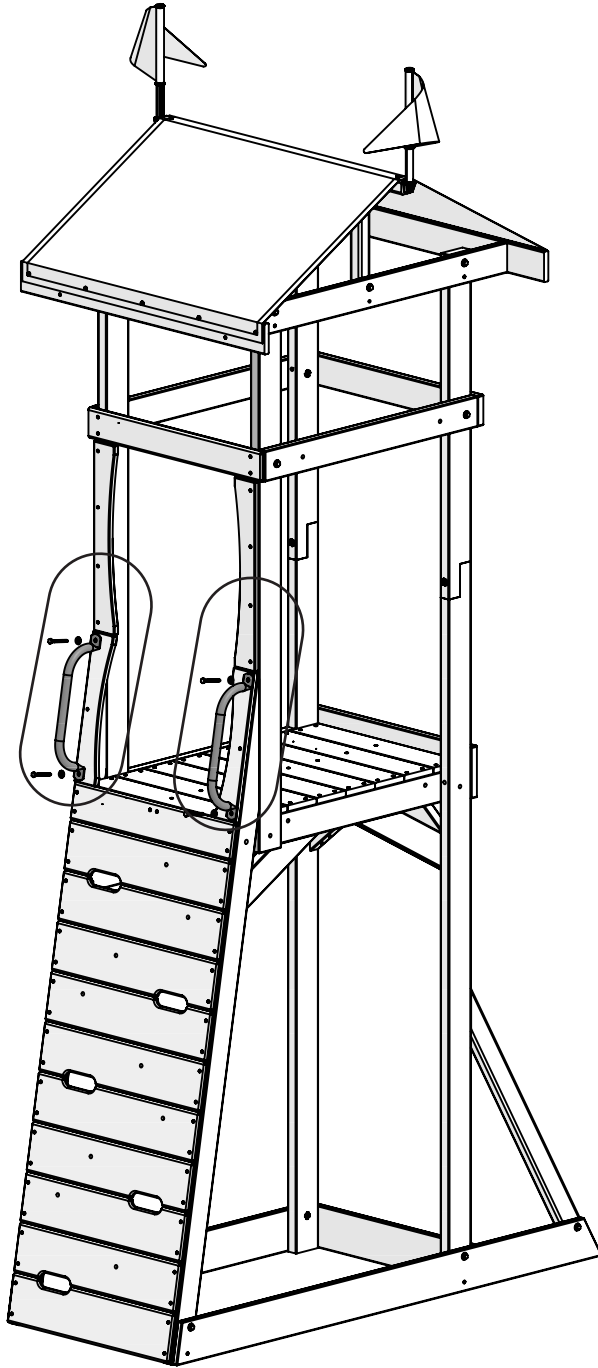
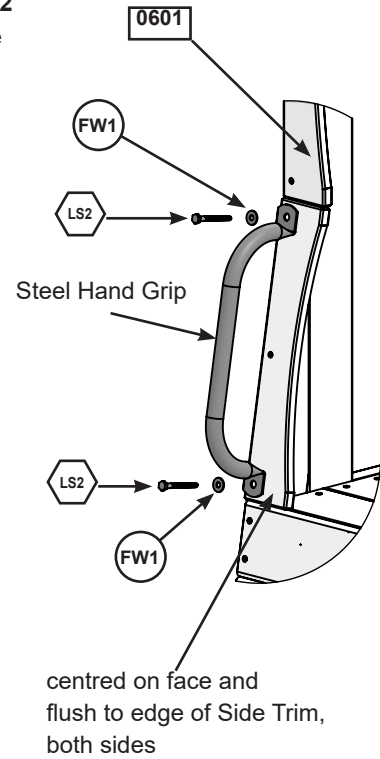



Fig. 51.2  
per side



**Hardware**  
4 x  1/4 x 2-1/2" Lag Screws (FW1)

**Other Parts**  
2 x Steel Hand Grip

# Step 52: Attach SL Brace

**A:** On the left side wall, place 1 (6022) SL Brace against the (6017) Floor Support making sure that it's flush with the top of the floorboards. Attach using 2 (H3) ¼ x 2-1/2" Hex Bolt (with flat washer, lock washer and t-nut). (Fig. 52.1 & 52.2 & 52.3)

**B:** Center the (6005) Slide Block vertically in the slide opening ensuring that it's flush to the bottom of (6022) SL Brace and attach to the (6017) Floor Support using 2 (S11) #8 x 2" Wood Screws. (Fig. 52.1 & 52.2 & 52.3)

**C:** From inside the assembly place 1 (6032) TNR Wall so it's pressed against the inside of the (6005) Slide Block, (6026) Rock Rail and (6002) Long Post. Ensure that the bottom of the (6032) TNR Wall is flush with the bottom of the (6005) Slide Block and attach with 7 (S11) #8 x 2" Wood Screws. (Fig. 52.1 & 52.2 & 52.3).

Fig. 52.1  
left side wall

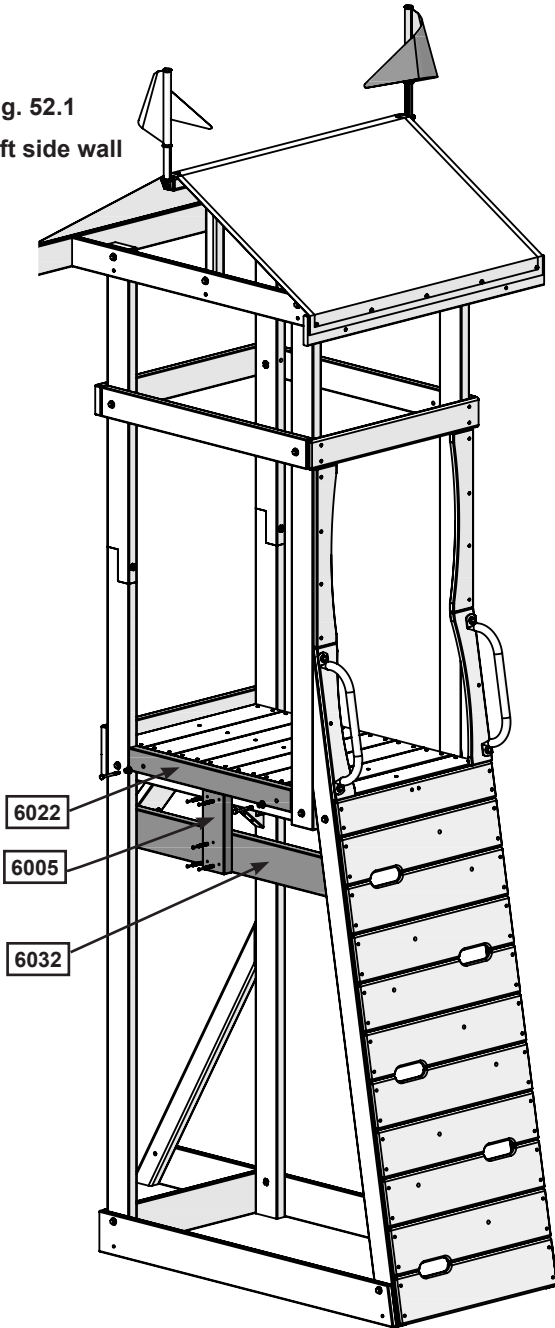


Fig. 52.2  
inside

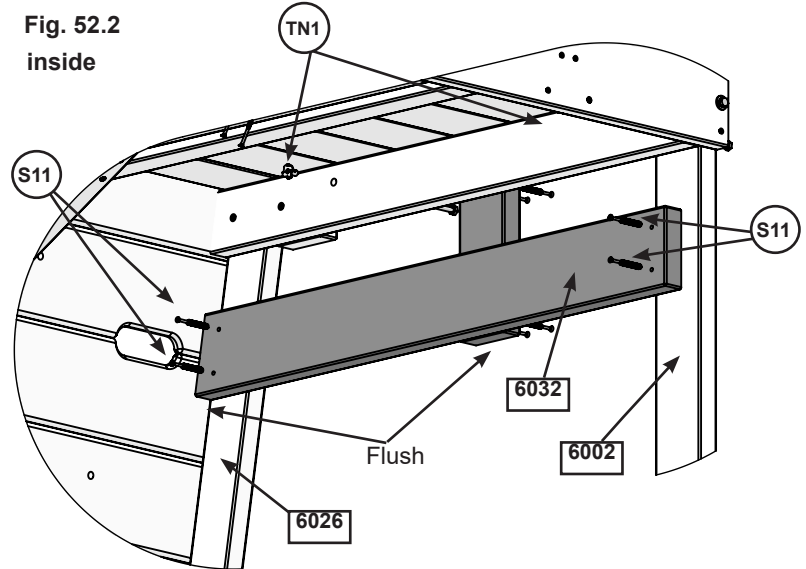
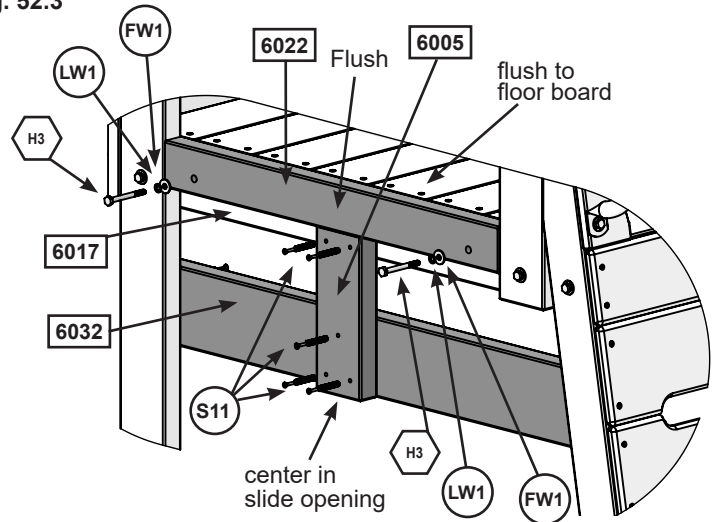


Fig. 52.3



## Wood Parts

- 1 x 6022 SL Brace 1-1/4 x 2-1/2 x 24-1/4"
- 1 x 6005 TNR Slide Block 1-1/4 x 3-1/4 x 8-3/4"
- 1 x 6032 TNR Wall 1-1/4 x 4-1/4 x 34-3/4"

## Hardware

- 9 x S11 #8 x 2" Wood Screws
- 2 x H3 ¼ x 2-1/2" Hex Bolt (LW1, FW1, TN1)

# Step 53: Attach Tunnel Wall Assembly



**A:** On the left side of the tunnel wall place 1 (6007) Wall Support beside the (6000) Upper Post. The top of the (6007) Wall Support should be behind the (6030) Tunnel Side Top and the bottom end should be on the outside of the (6017) Floor Support. Attach using 1 (H2) ¼ x 2" Hex Bolts (with flat washer, lock washer and t-nut) in tunnel side and 1 (H3) ¼ x 2-1/2" Hex Bolt in Floor Support. (Fig. 53.1 & 53.2)

**B:** Repeat step A to install a second (6007) Wall Support on the right side of the tunnel wall. (Fig. 53.1 & 53.2)

**C:** Measure to ensure that there is a 17" (432mm) space between the 2 (6007) Wall Supports and attach 1 (6014) Tunnel Spacer flush to the top of the floor boards with 5 (S11) #8 x 2" Wood Screws. (Fig. 53.1 & 53.2)

Fig. 53.1

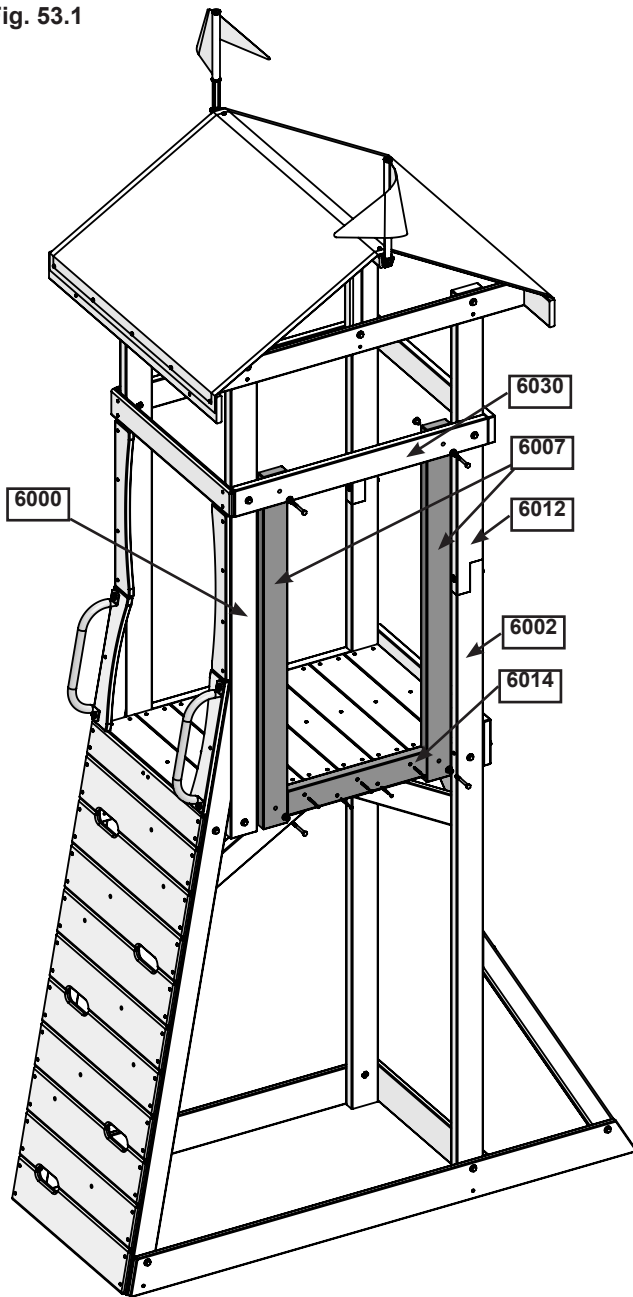
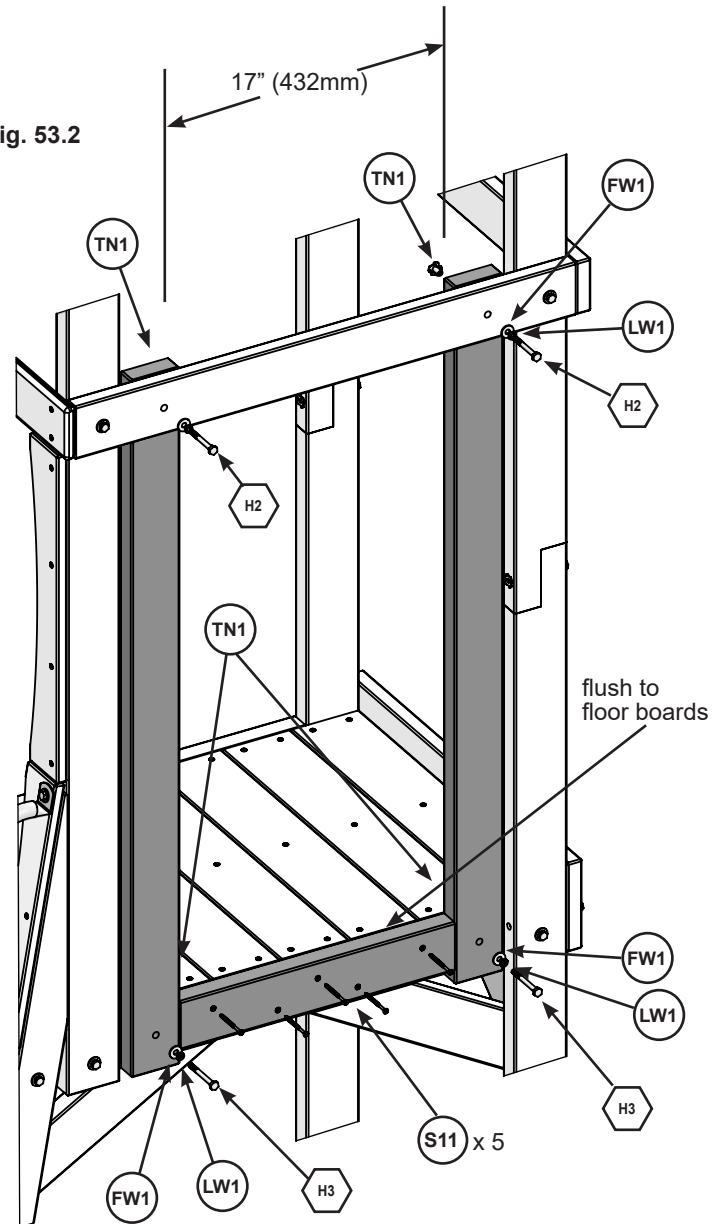


Fig. 53.2



### Wood Parts

- 2 x **6007** Wall Support 1-1/4 x 3 x 43-1/8"
- 1 x **6014** Tunnel Spacer 1-1/4 x 3 x 16-15/16"

### Hardware

- 5 x **(S11)** #8 x 2" Wood Screws
- 2 x **(H3)** ¼ x 2-1/2" Hex Bolt (LW1, FW1, TN1)
- 2 x **(H2)** ¼ x 2" Hex Bolt (LW1, FW1, TN1)

# Step 54: Attach Rocks to Climbing Wall

**A:** Alternating colours and shapes, attach 1 rock to each rock board using 1 (PB2) ¼ x 1-1/4" Pan Bolt (with ¼" lock washer, 3/16" flat washer and ¼" barrel nut) and 1 (S10) #8 x 1" Pan Screw per rock. (Fig. 54.1 & 54.2 & 54.3)

The Pan Screw is placed in the hole beneath the Pan Bolt.

**Make sure all hardware is used to secure each rock properly.**

Fig. 54.1

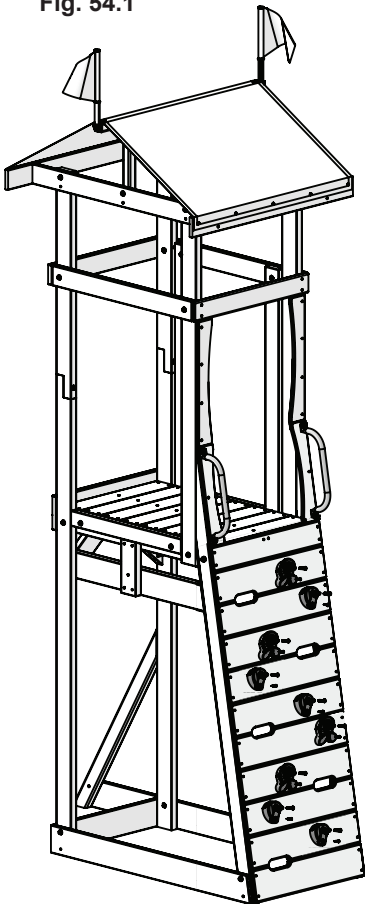


Fig. 54.2

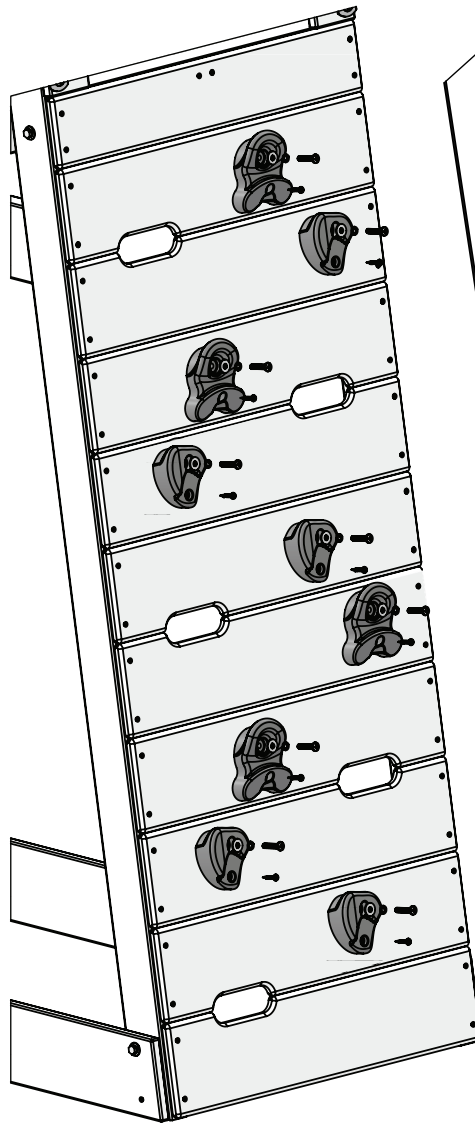
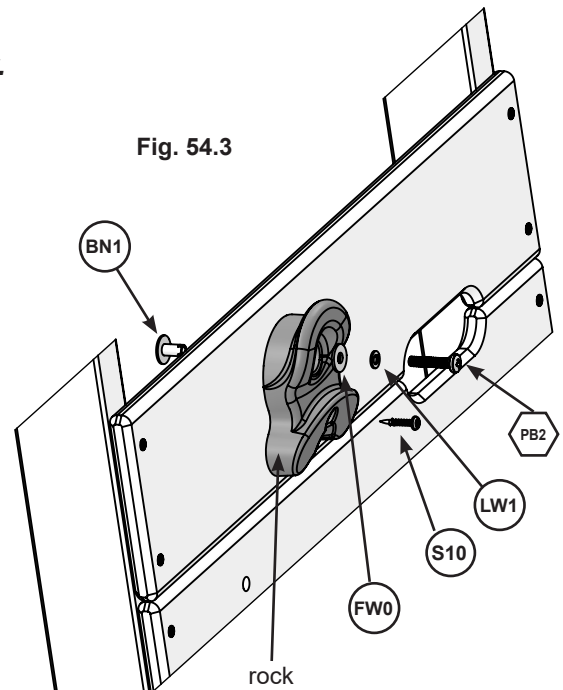


Fig. 54.3



## Hardware

- 9 x (S10) #8 x 1" Pan Screw
- 9 x (PB2) ¼ x 1-1/4" Pan Bolt (LW1, FW0, BN1)

## Other Parts

- 9 x Rocks

# Step 55: Attach Telescope

**A:** On the Back Wall, center the Telescope and attach to (6028) Top Back with 2 (S20) #8 x 1-3/8" Wood Screws. (fig. 55.1 & 55.2)

**Move Assembly to final location.(fig. 55.3)**

Fig. 55.1

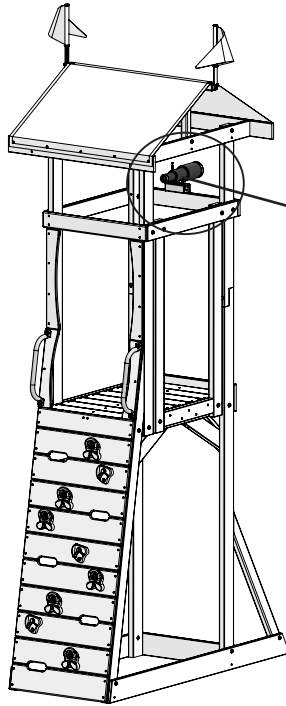


Fig. 55.2

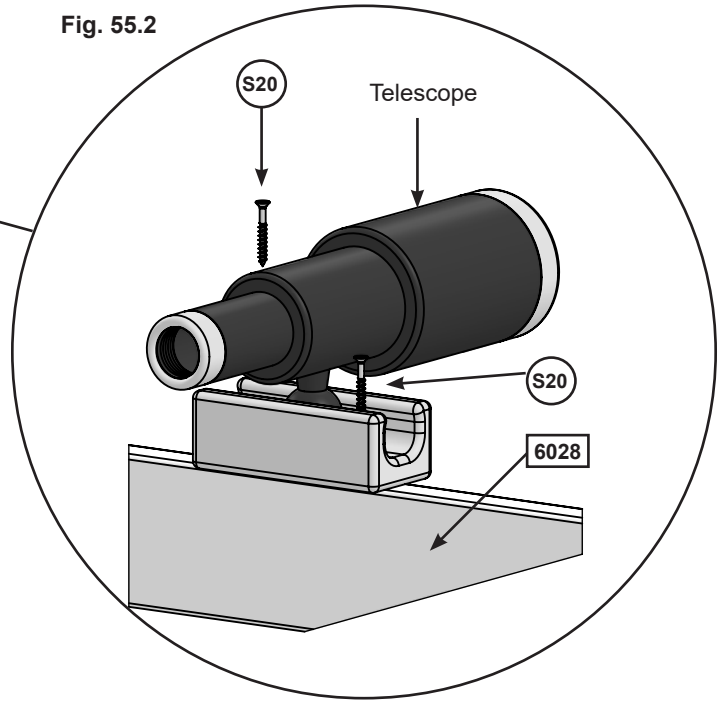
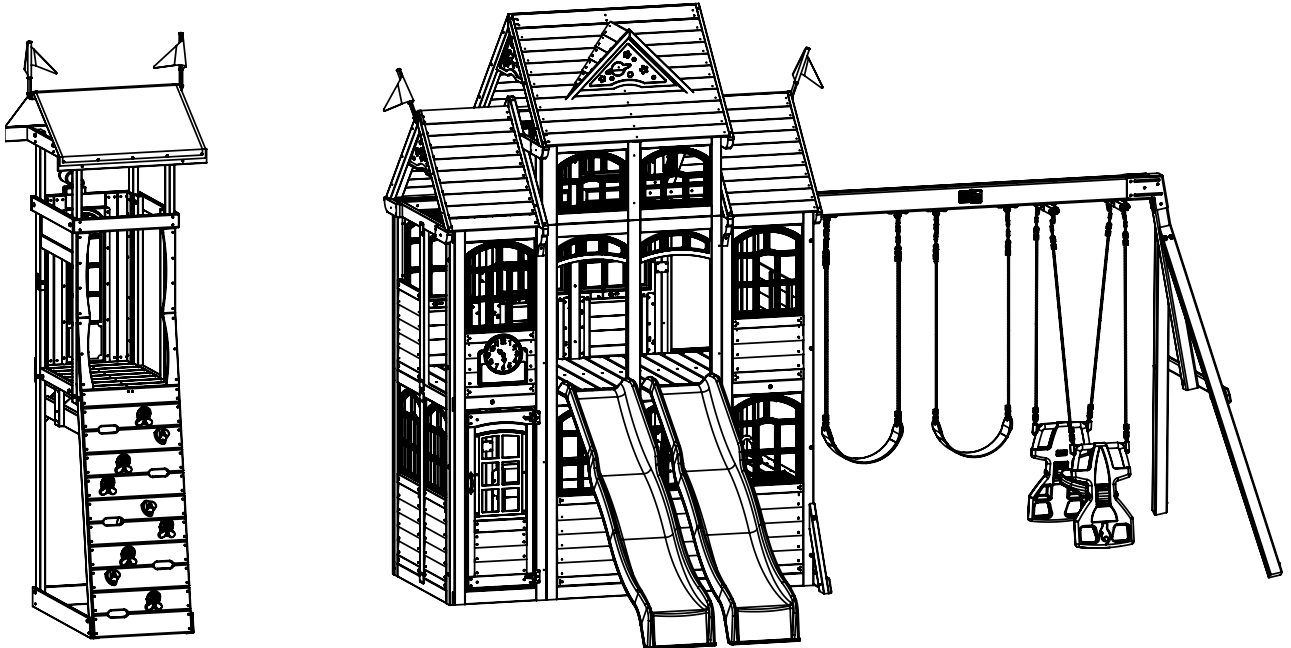



Fig. 55.3



approximately 67" apart with the openings lining up

## Hardware

2 x  #8 x 1-3/8" Wood Screw

## Other Parts

1 x Telescope w/ Mount

# 6' Tunnel & Tire Swing Assembly

## Step 56: Attach Swing Hangers to Tire Joist

**A:** Position 1 (6036) Tire Joist so that the counter sunk holes are at the top. Attach the Swing Hangers from underneath (2 flat washer and 1 lock nut per swing hanger) as shown in fig. 56.1 and 56.2.

Fig. 56.1

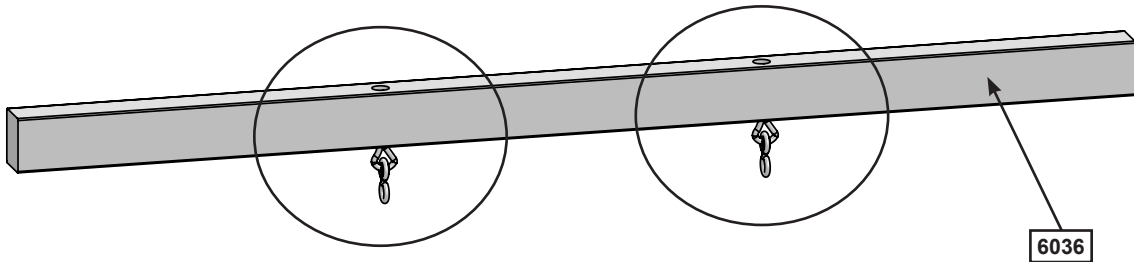
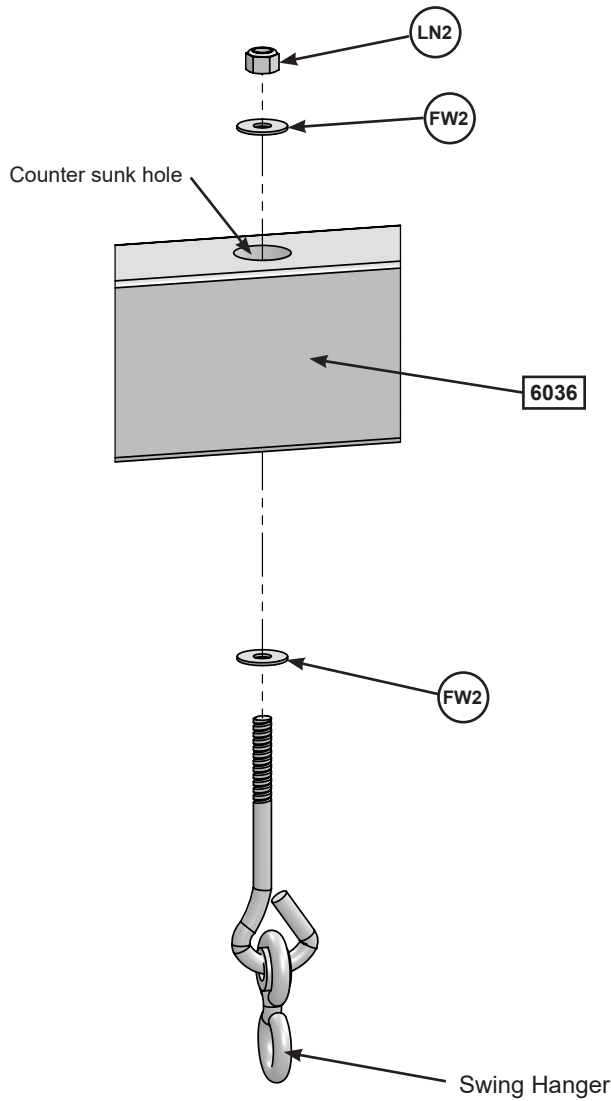


Fig. 56.2



### Wood Parts

1 x 6036 Tire Joist 2-1/2 x 3-1/4 x 66-15/16"

### Other Parts

2 x Swing Hanger

# Step 57: Tunnel Frame Assembly Part 1

**A:** Place 2 (6035) Tunnel Side Joists side by side making sure that the pre-drilled holes for the t-nuts are at the top. Install 1 5/16" T-Nut on the inside of all 4 ends. (fig. 57.1 and 57.2)

Fig. 57.1

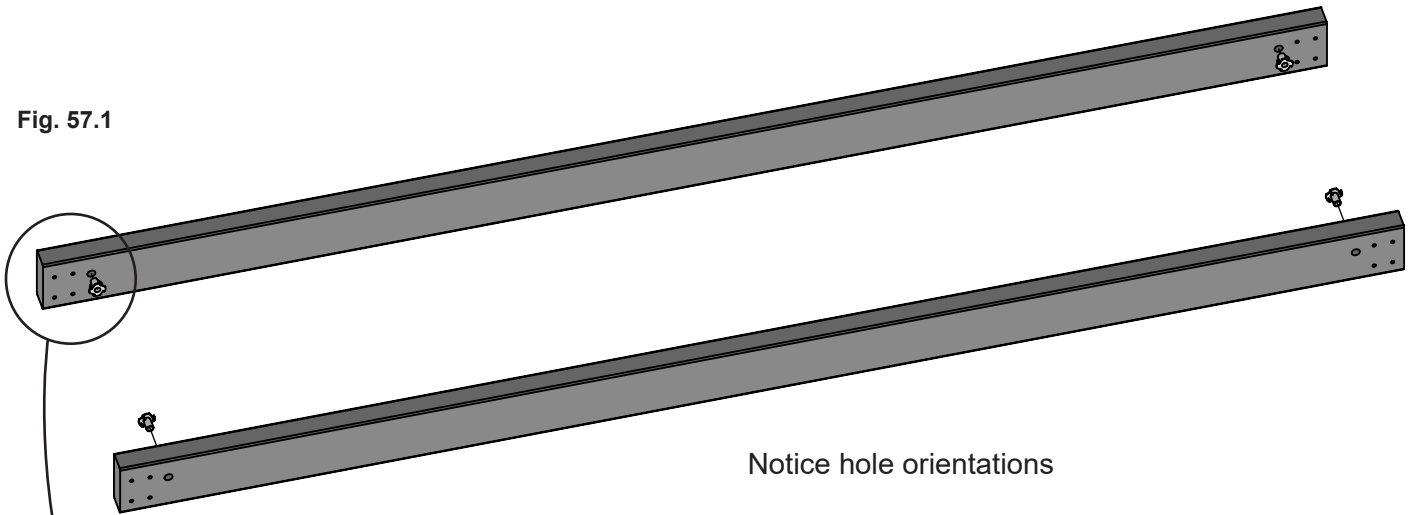
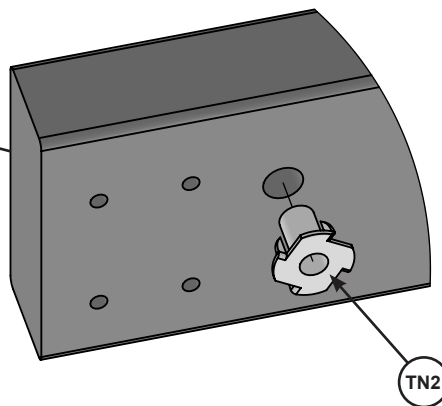


Fig. 57.2



## Wood Parts

2 x 6035 Tunnel Side Joist 1-1/4 x 3-1/4 x 69-11/16"

## Hardware

4 x 5/16" TN2

# Step 57: Tunnel Frame Assembly Part 2

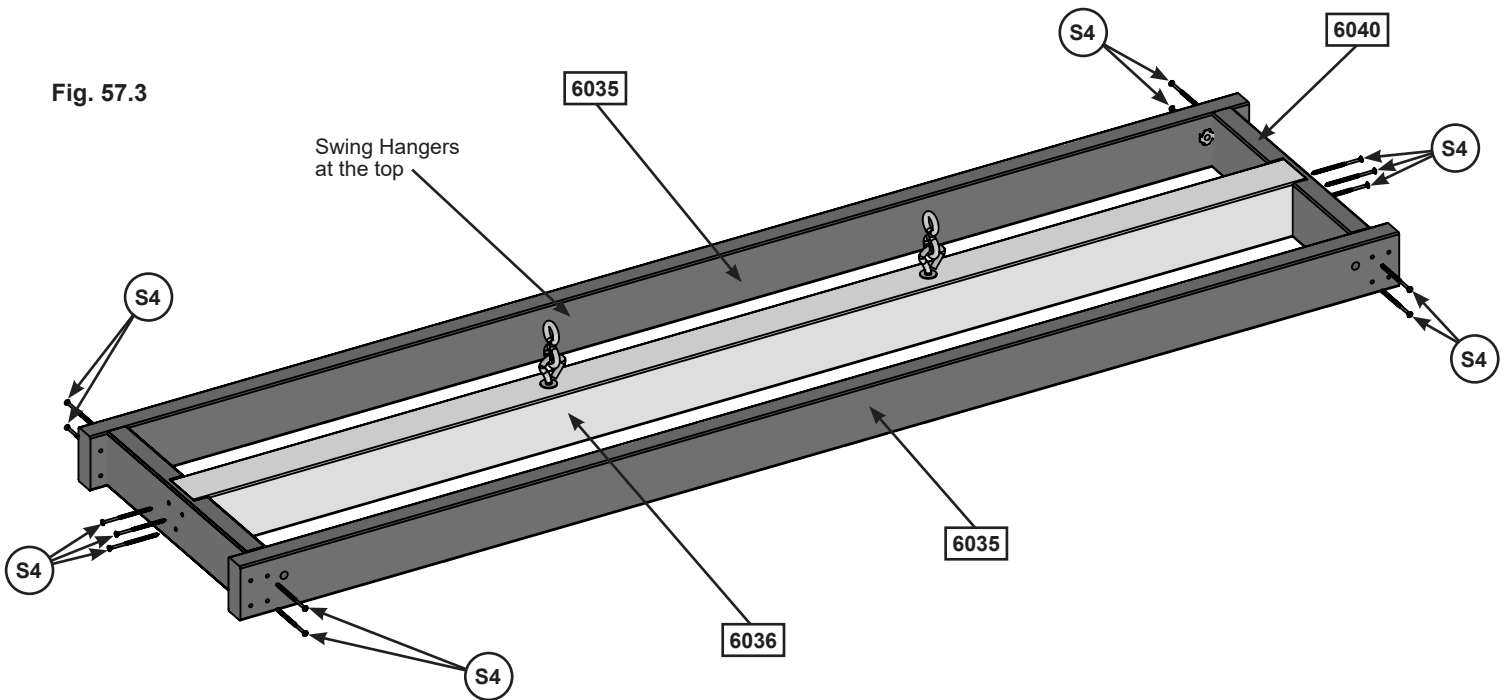


**B:** Place the (6036) Tire Joist in between the (6035) Tunnel Side Joists with Swing Hangers at the top. (fig. 57.3)

**C:** Place 1 (6040) Tunnel End at each end of the joists so that the (6036) Tire Joist fits into the cut outs (fig.57.3). Attach (6040) Tunnel Ends to (6036) Tire Joist using 3 (S4) #8 x 3" Wood Screws per end and then attach (6035) Tunnel Side Joists to (6040) Tunnel Ends with 4 (S4) #8 x 3" Wood Screws per side making sure to use the inside holes as shown in fig. 57.3.

**Make sure assembly is square before proceeding to the next step.**

Fig. 57.3



### Wood Parts

2 x 6040 Tunnel End 1-1/4 x 3-1/4 x 14-1/2"

### Hardware

14 x S4 #8 x 3" Wood Screw



# Step 58: Attach Floor Boards



**A:** Flip the frame assembly so that it's right side up. (fig. 58.1)

**B:** Place 1 (10077) Floor Board at the end of the tunnel frame so it's flush with the ends and the sides of the (6035) Tunnel Side Joists and attach using 5 (S2) #8 x 1-1/2" Wood Screws. (fig. 58.1 and 58.2)

**C:** Place 1 (10078) Floor Board at the other end of the tunnel frame ensuring that it's flush with the ends and the sides of the (6035) Tunnel Side Joists and attach using 5 (S2) #8 x 1-1/2" Wood Screws. (fig. 58.1 and 58.2)

**D:** Evenly space the remaining (10077) Floor Boards and attach all boards using 5 (S2) #8 x 1-1/2" Wood Screws per board. (fig. 58.1 and 58.2)

**Note: Pre-drill center holes with 3/16" drill bit.**

Fig. 58.1

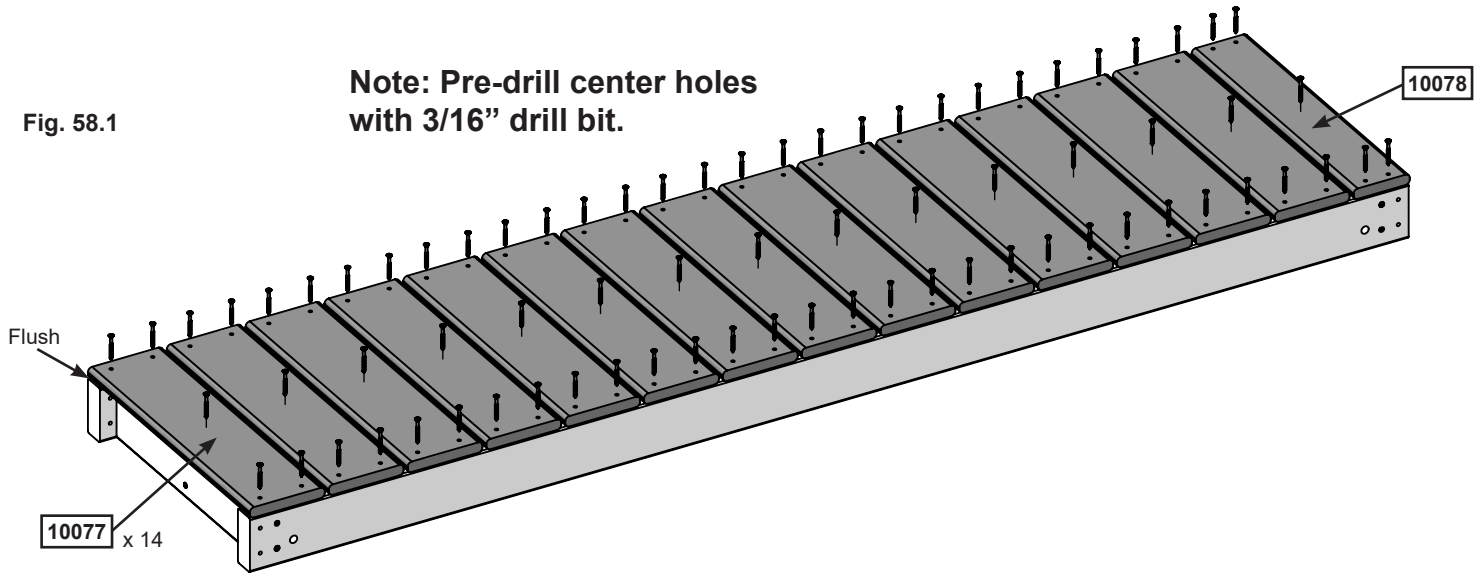
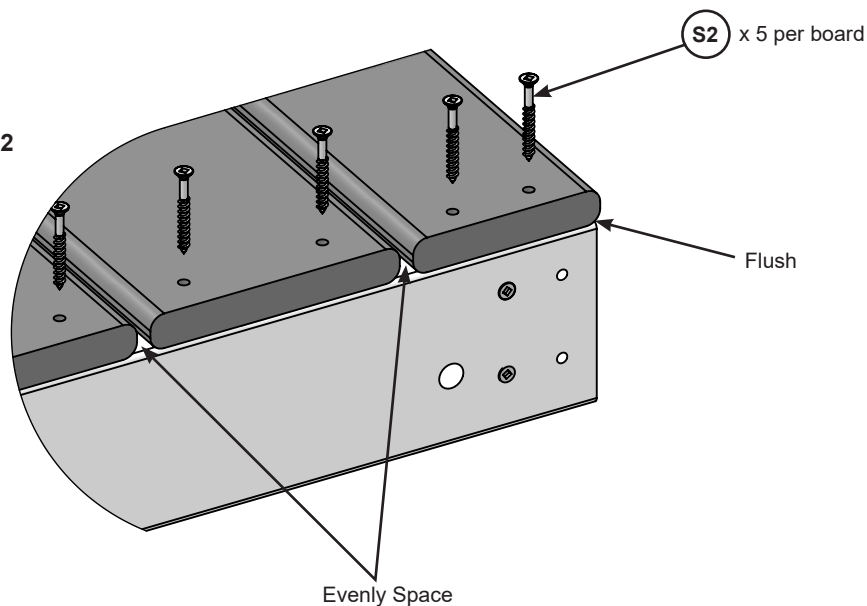


Fig. 58.2



## Wood Parts

14 x Floor Board 5/8 x 4-1/2 x 16-7/8"

1 x Floor Board 5/8 x 3-3/4 x 16-7/8"

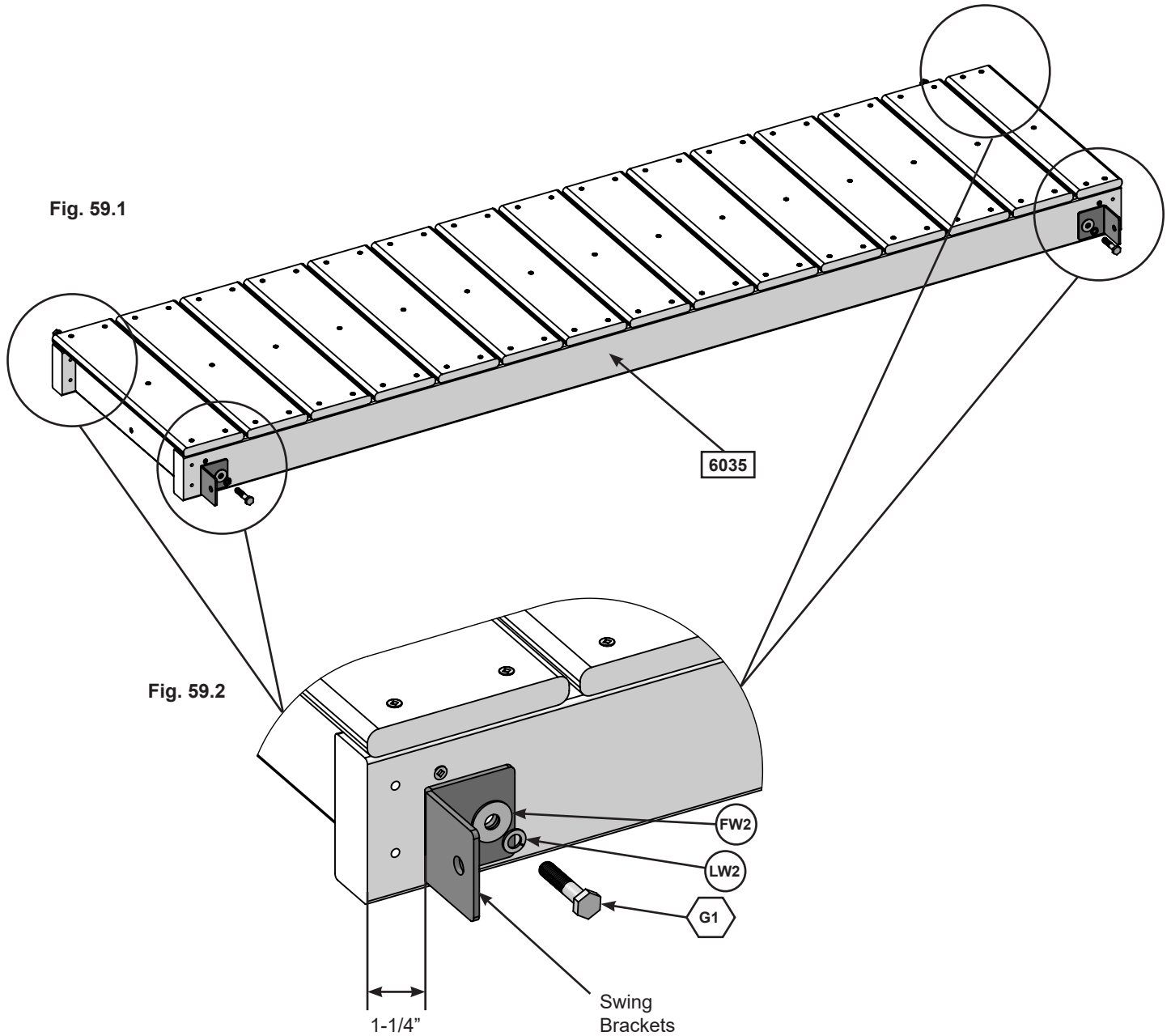
## Hardware


75 x #8 x 1-1/2" Wood Screw

# Step 59: Install Swing Brackets



**A:** From outside the tunnel assembly, measure 1-1/4" in from each end of the (6035) Tunnel Side Joists and attach 4 Swing Brackets using 1 (G1) 5/16 x 1-1/2" Hex Bolt (with flat washer and lock washer) per bracket. (fig. 59.1 and 59.2)



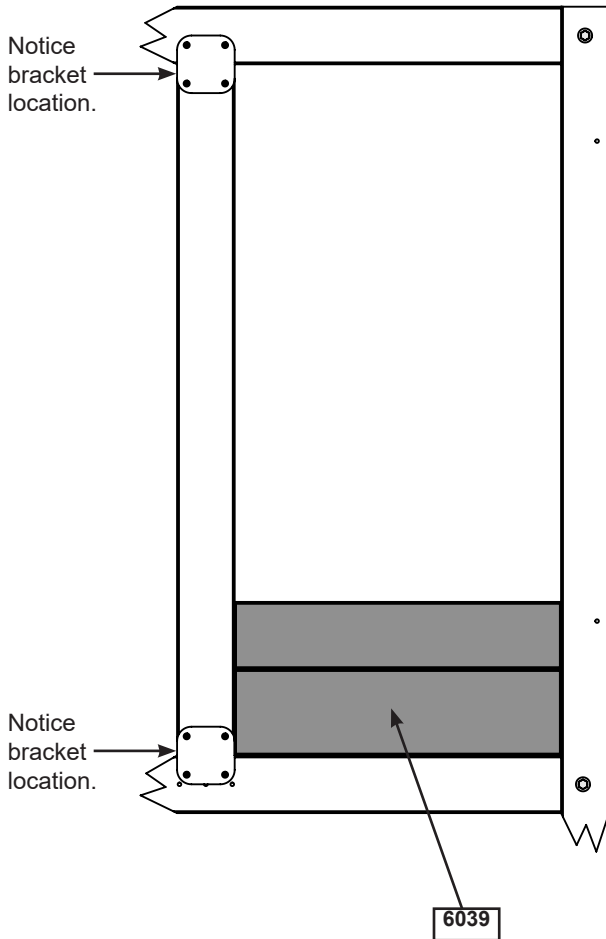
**Hardware**  
4 x  5/16 x 1-1/2" Hex Bolt (LW2, FW2)

**Other Parts**  
4 x 3201532

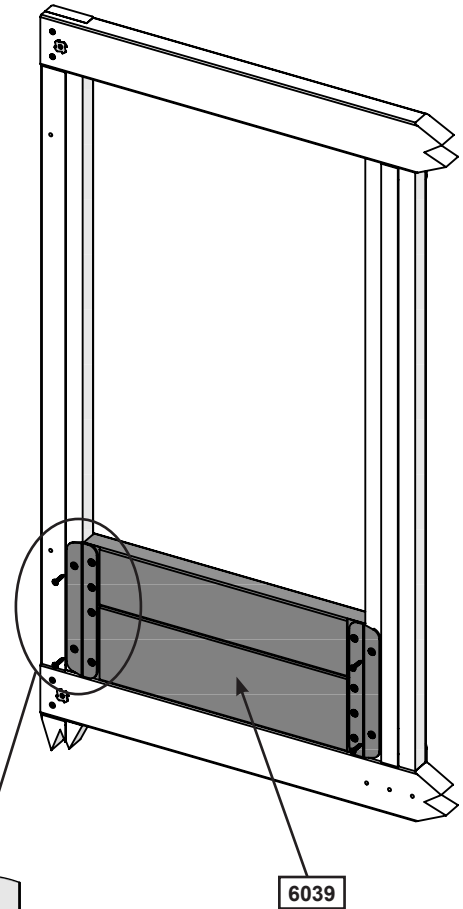
# Step 60: Install Lower Tunnel Insert

**D:** From inside the fort place the (6039) Lower Tunnel Insert into the bottom of the opening in the tunnel entrance as shown in fig. (60.1 and 60.2). Attach to the Wall Supports with 4 (S0) #8 x 7/8" Truss Screws. (fig. 60.2 and 60.3)

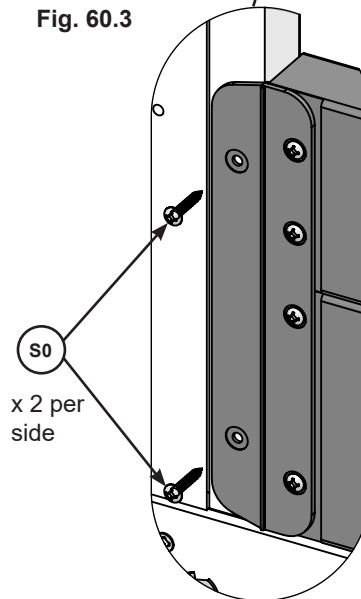
**Fig. 60.1**  
Outside View



**Fig. 60.2**  
Inside View



**Fig. 60.3**



## Wood Parts

1 x **6039** Lower Tunnel Insert 1-1/4 x 8 x 18-3/4"

## Hardware

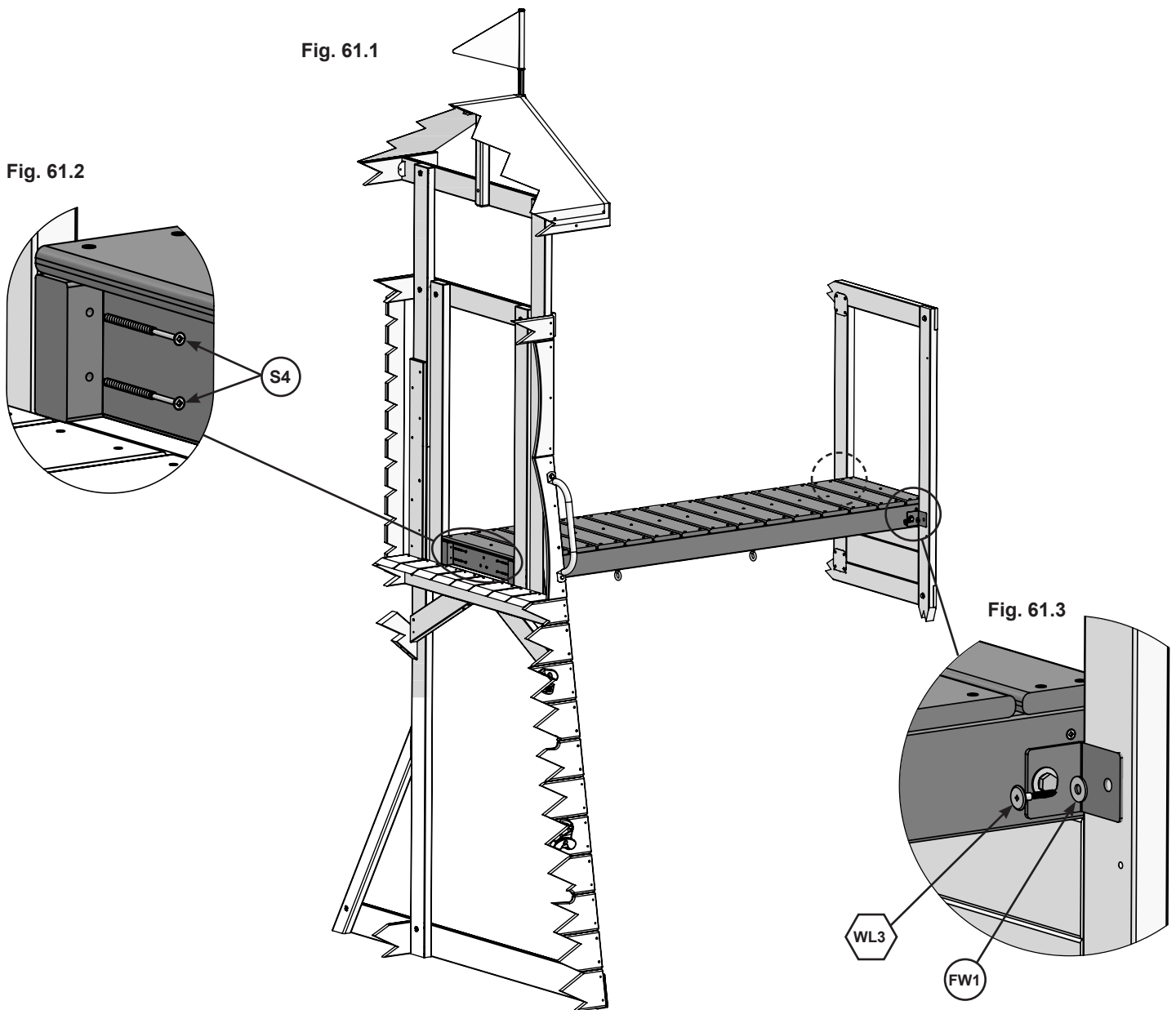
4 x **S0** #8 x 7/8" Truss Screw

# Step 61: Attach Tunnel Assembly Frame to Fort Part 1





## Note: Move Adventure Tower to final location

- A:** With a helper, lift the tunnel assembly frame so that it fits between the Adventure Tower and the Fort as shown in fig. 61.1.
- B:** From inside the Adventure Tower attach the (6035) Tunnel Side Joists to the Wall Supports using 4 (S4) #8 x 3" Wood Screws. (fig. 61.1 and 61.2)
- C:** Repeat Step B for the fort side.
- D:** From outside the assembly pre drill 1/8" holes and attach the Swing Brackets to the Tower and Fort frames using 1 (WL3) 1/4 x 1-3/8" Wafer Lag (with flat washer) per bracket. (fig. 61.1 and 61.3)



### Hardware

8 x  8 x 3" Wood Screw

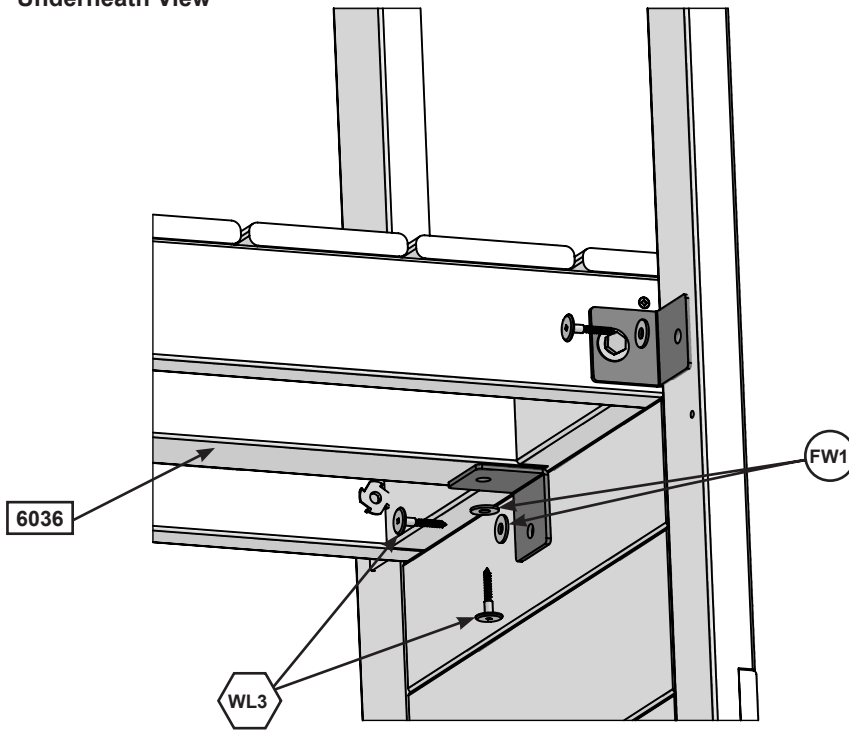
4 x  1/4 x 1-3/8" Wafer Lag (FW1)


# Step 61: Attach Tunnel Assembly Frame to Fort Part 2



**E:** From underneath the tunnel place 1 Swing Bracket on each end of the (6036) Tire Joist. Pre-drill holes using a 1/8" drill bit and connect to the structures using 2 (WL3) 1/4 x 1-3/8" Wafer Lags (with flat washers) per side. (fig. 61.4)

**Fig. 61.4**  
Underneath View



**Hardware**  
4 x  1/4 x 1-3/8" Wafer Lag (FW1)

**Other Parts**  
2 x Swing Bracket

## Step 62: Install Upper Tunnel Insert



**A:** From inside the Adventure Tower measure 1-5/8" down from the top of the Wall Support as shown in fig. 46.2 and place the (6038) Upper Tunnel Insert into the opening. Attach to the Wall Supports using 4 (S0) #8 x 7/8" Truss Screws. (fig. 62.1 and 62.2)

Fig. 62.1

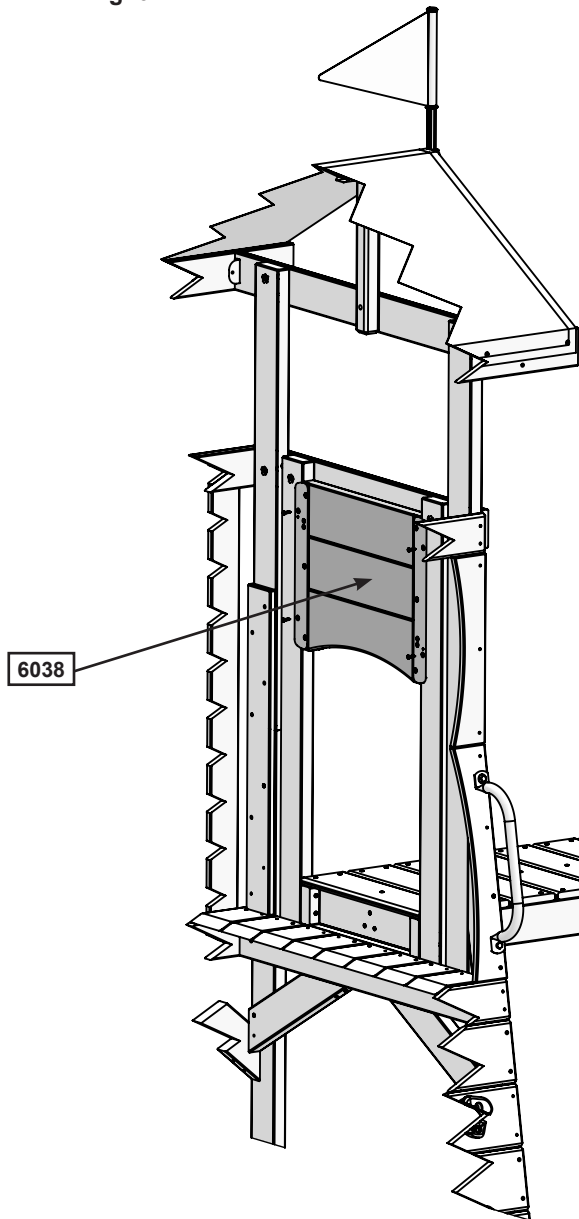
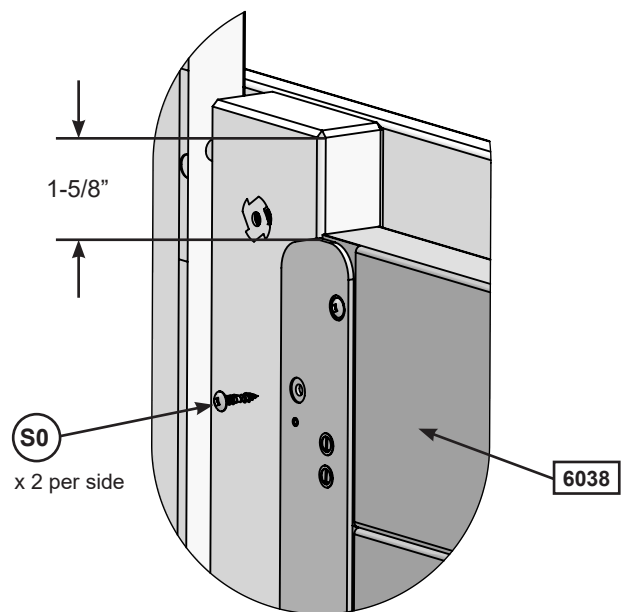


Fig. 62.2



### Wood Parts

1 x **6038** Upper Tunnel Insert 1-1/4 x 14-1/4 x 18-3/4"

### Hardware

4 x **S0** #8 x 7/8" Truss Screw

# Step 63: Build Tunnel Assembly Part 1

**A:** Bend all 8 MOD Tunnel Panels as shown in fig. 63.1.

**B:** Match 2 MOD Tunnel Panels together by making a slight “V” with the pieces so the peak of the “V” faces away from you. Make sure connector tabs are coupled then straighten the 2 panels. Push down on one panel and up on the other until you hear the connector tabs click together and the bottom edges are flush. You may have to knock panels on a hard surface to align properly. Do this so there are 4 MOD Tunnel Panels attached together. (fig. 63.2)

**C:** Press nodules through the connector tab holes to hold Tunnel Panels in place. (fig. 63.2 and 63.3)

**D:** Repeat Steps B-C to create two Tunnel Sides.

Fig. 63.1

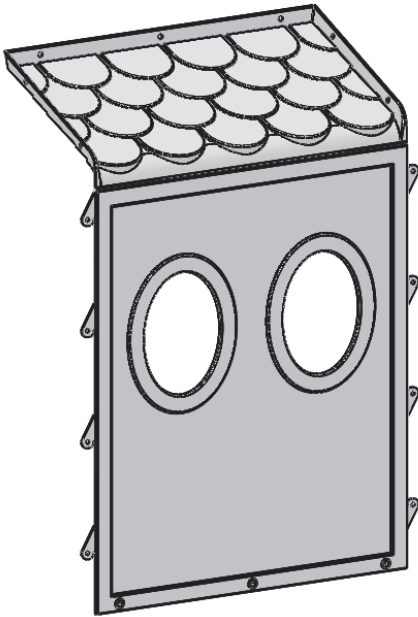


Fig. 63.2

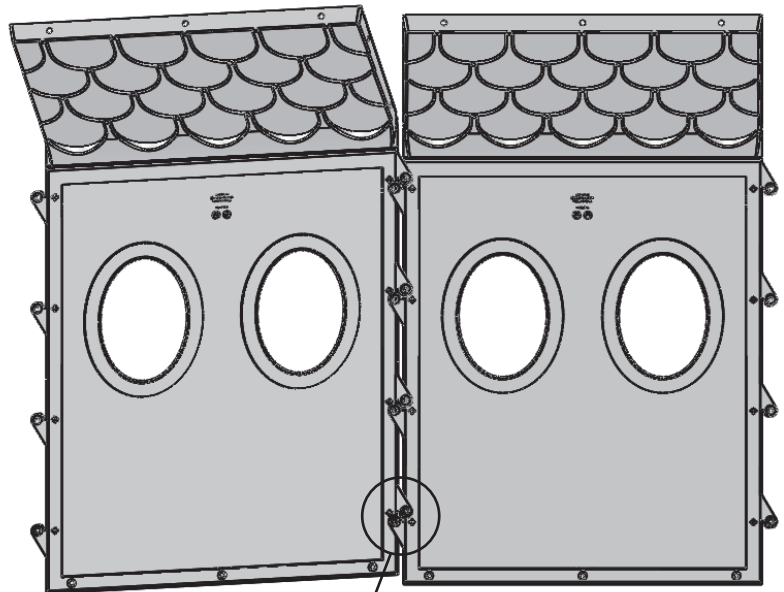
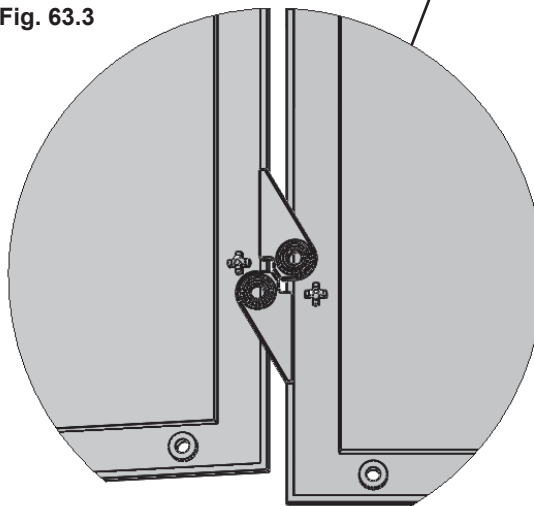


Fig. 63.3



## Other Parts

8 x MOD Tunnel Panel

# Step 63: Build Tunnel Assembly Part 2 x 2



**E:** Attach the tops of each Tunnel Side together using 2 (MB1) #12 x 1/2" Pan Bolts (with #12 Lock Nut) per side. (fig. 63.4 and 63.5)

Fig. 63.4

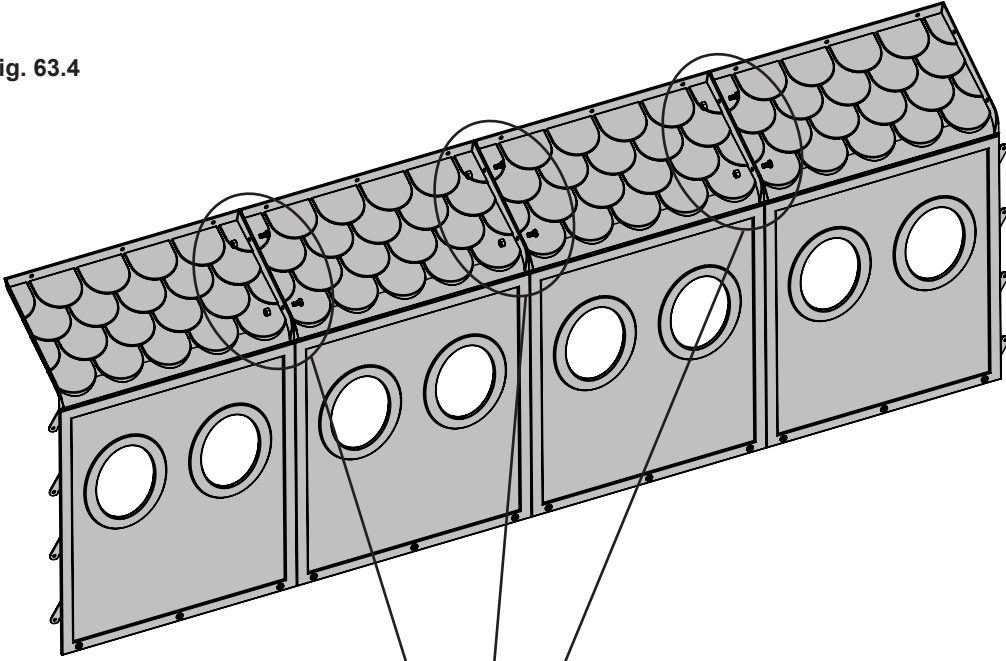
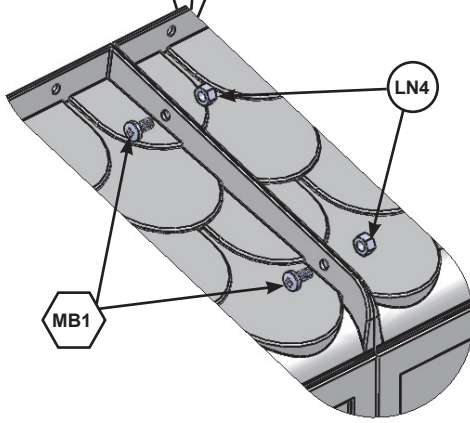



Fig. 63.5



**Hardware**  
12 x  #12 x 1/2" Pan Bolt (LN4)



# Step 63: Build Tunnel Assembly Part 3



F: Join the 2 Tunnel Sides together so the tops are tight together and attach with 12 (MB1) #12 x 1/2" Pan Bolts (with #12 Lock Nut). (fig. 63.6 and 63.7)

Fig. 63.6

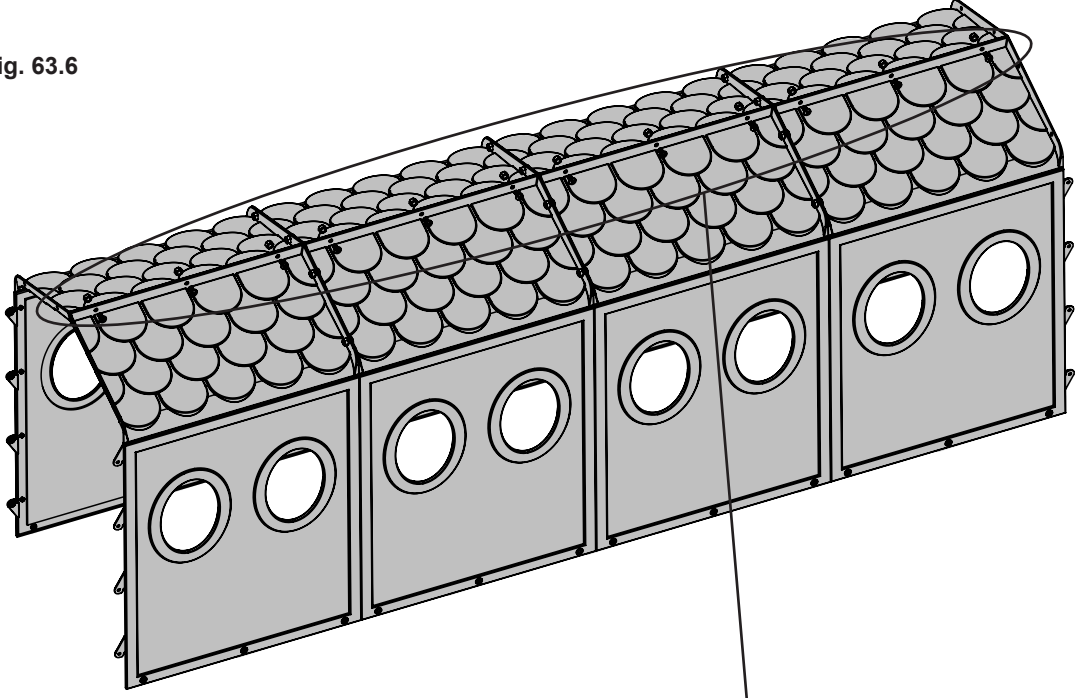
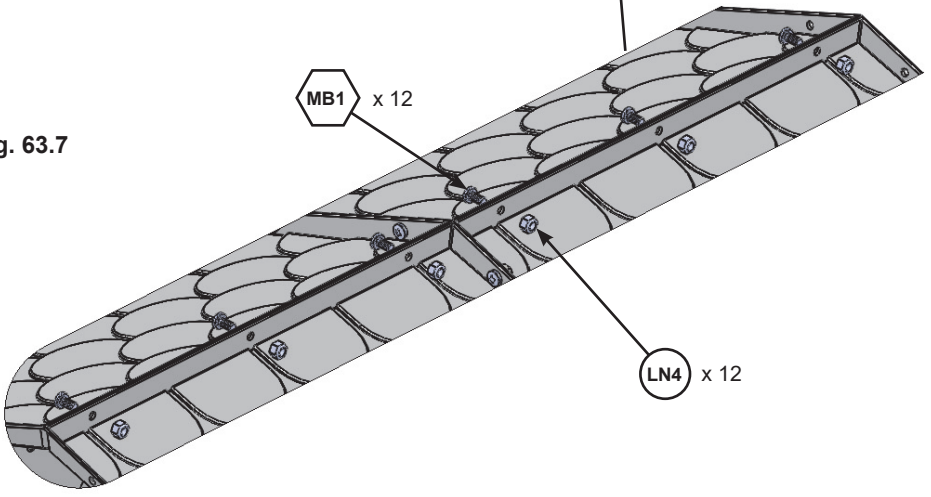


Fig. 63.7



### Hardware

12 x  #12 x 1/2" Pan Bolt (LN4)

# Step 64: Attach MOD Tunnel Part 1



**A:** With a helper, place the MOD Tunnel Assembly into place so that the bottom edge rests on the swing brackets and attach to the (6035) Tunnel Side Joists using 24 (S10) #8 x 1" Pan Screws. (fig. 64.1, 64.2 and 64.3)

Fig. 64.1

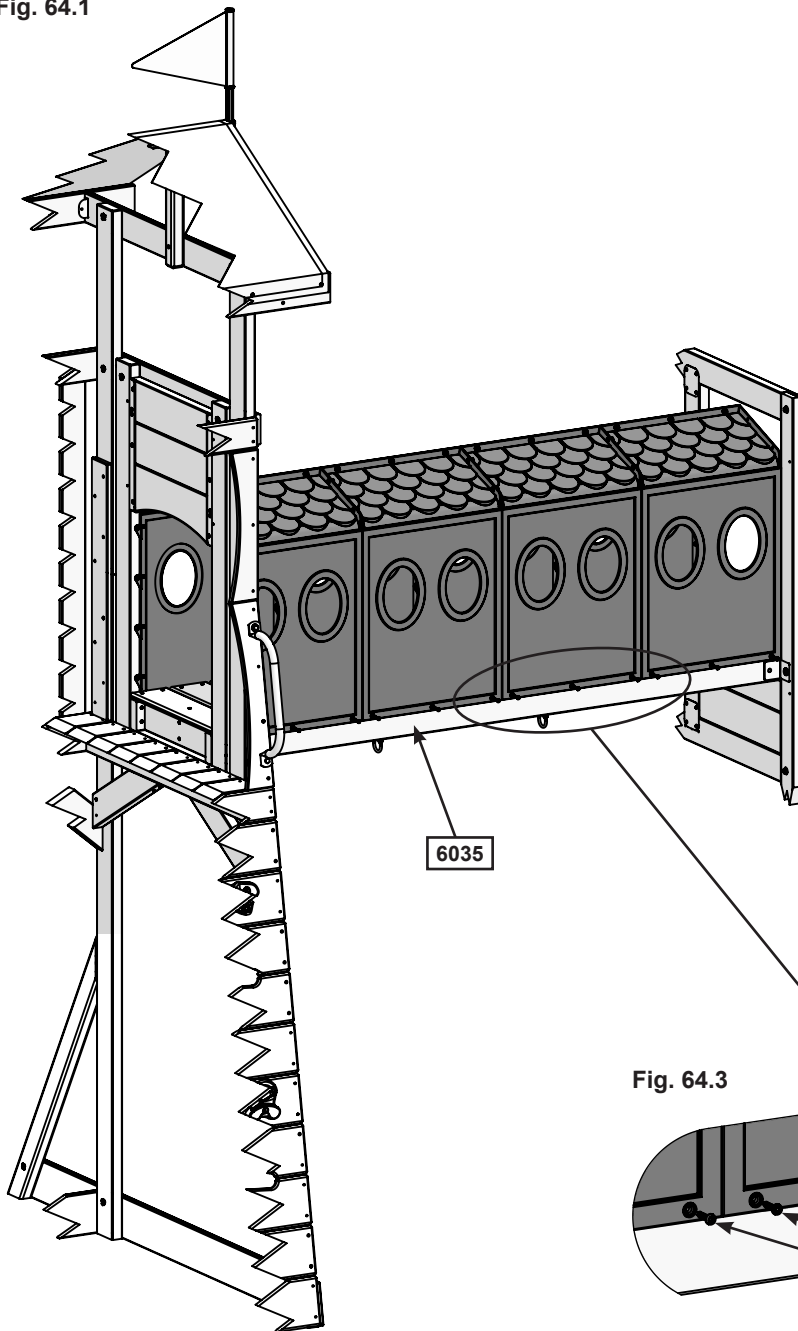


Fig. 64.2  
Side View

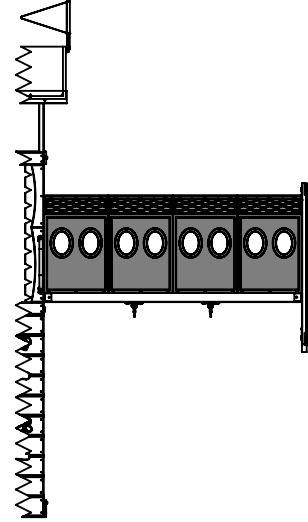
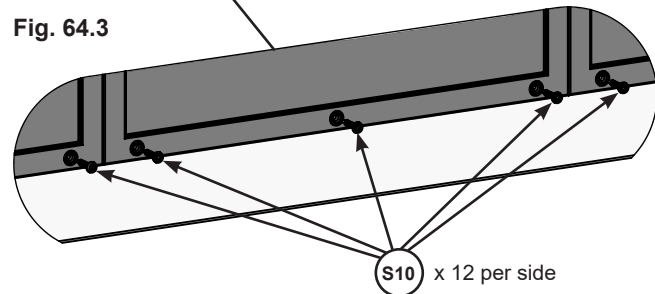



Fig. 64.3



## Hardware

24 x  #8 x 1" Pan Screw

# Step 64: Attach MOD Tunnel Part 2

**B:** From inside the fort attach 1 (6037) Tunnel Top to the Wall Support using 2 Flat Panel Brackets and 8 (S0) #8 x 7/8" Truss Screws. (fig. 64.4 and 64.5)

Fig. 64.4

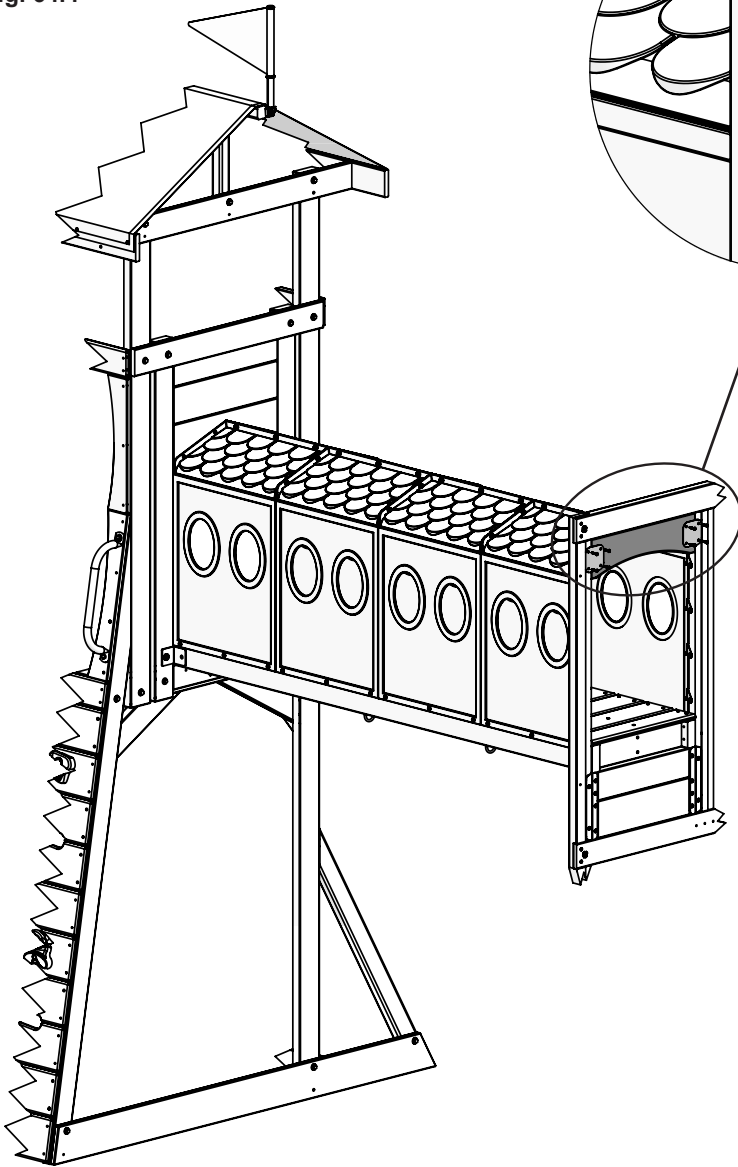
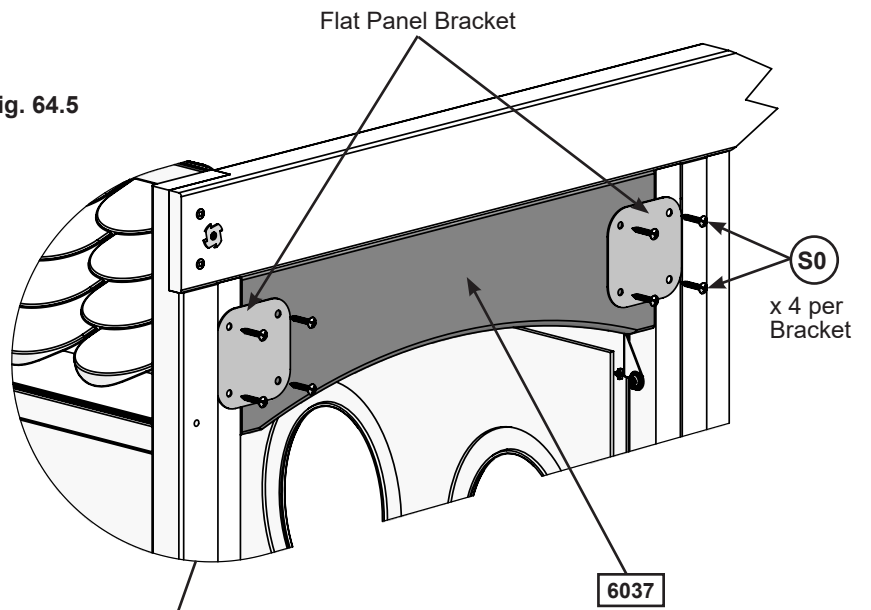


Fig. 64.5



### Wood Parts

1 x 6037 Tunnel Top 5/16 x 4-3/4 x 16-7/8"

### Hardware

8 x S0 #8 x 7/8" Truss Screw

### Other Parts

2 x 3200636

# Step 65: Secure Tunnel to Entrances

**A:** Make sure tunnel is tight to both entrances. From inside the tower and the fort attach the tunnel with 8 (S10) #8 x 1" Pan Screws per side. (fig. 65.1 and 65.2)

**B:** From outside the assembly attach Tunnel to the (6037) Tunnel Top on one side and to the (6038) Upper Tunnel Insert on the other using 4 (S0) #8 x 7/8" Truss Screws per side. (fig. 65.1& 65.3 and 65.4)

Fig. 65.2

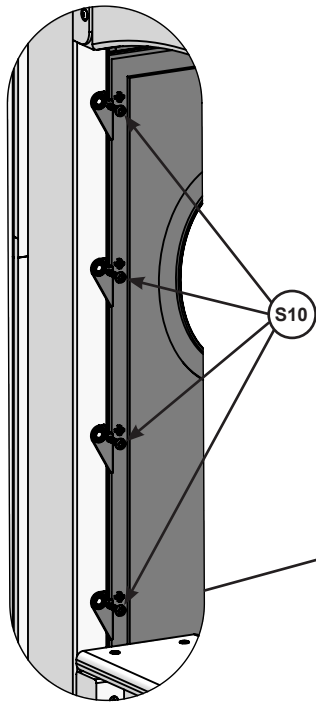


Fig. 65.1

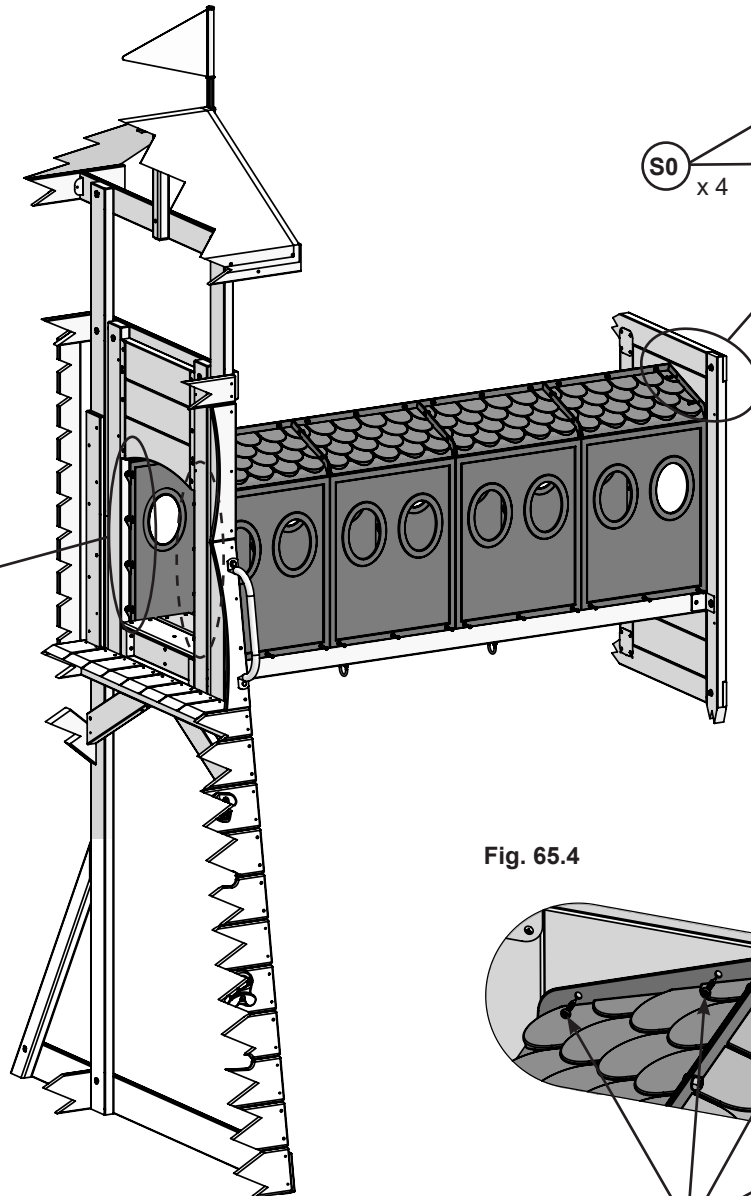


Fig. 65.3

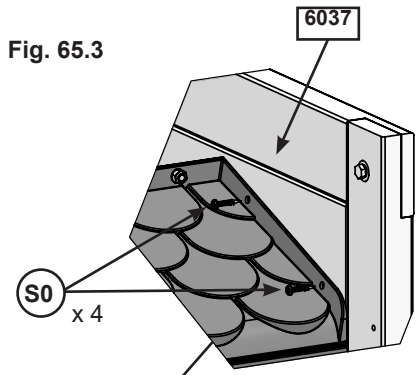
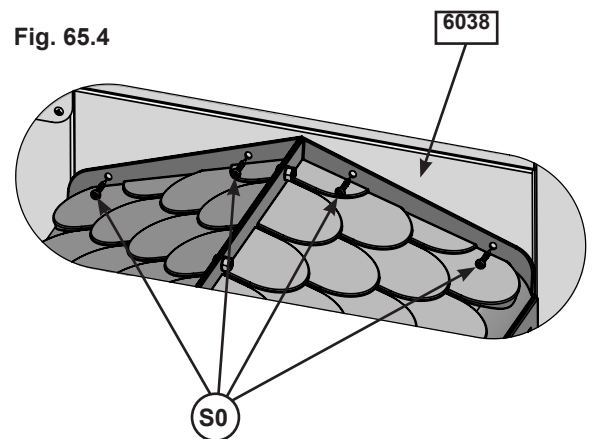


Fig. 65.4



## Hardware

- 16 x (S10) #8 x 1" Pan Screw
- 8 x (S0) #8 x 7/8" Truss Screw

# Step 66: Attach Tire Swing Part 1

**A:** Insert the eyebolts on the Tire Rope and Chains into the tire as shown in fig. 66.1. Attach using 1 flat washer and 1 lock nut per eyebolt. (fig. 66.1 and 66.2)

Fig. 66.1

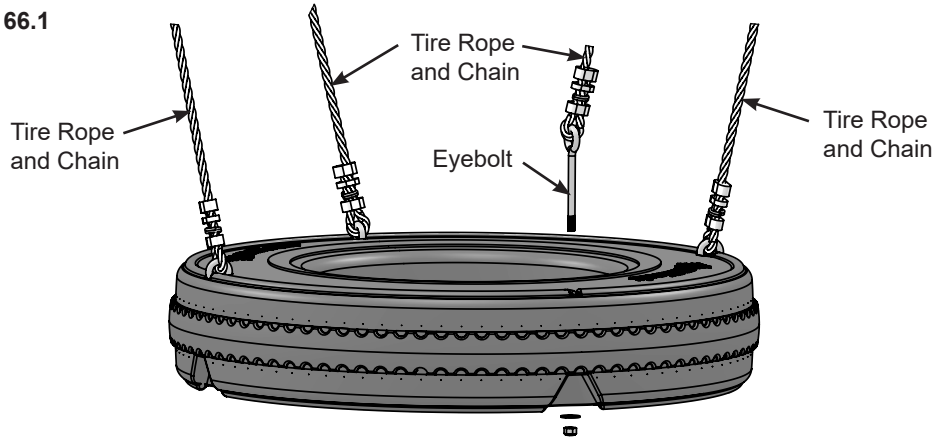
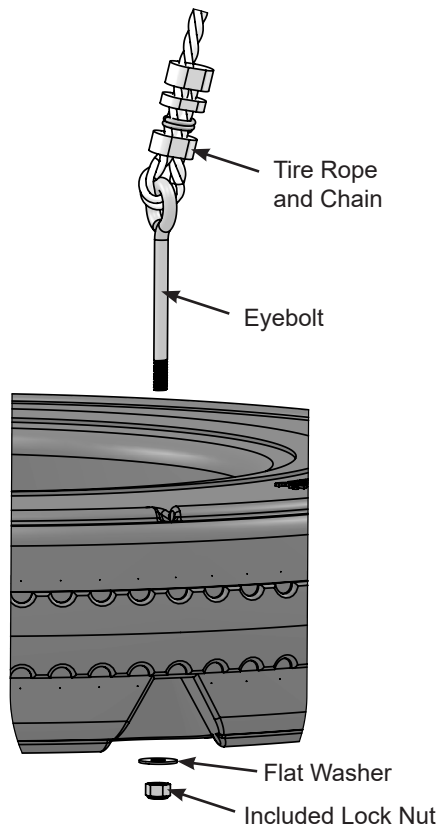


Fig. 66.2



### **Other Parts**

4 x Tire Rope and Chain  
1 x 3320702

# Step 66: Attach Tire Swing Part 2

**B:** Attach Tire Rope and Chain to the swing hangers as shown in fig. 66.3, 66.4 and 66.5.

Fig. 66.3

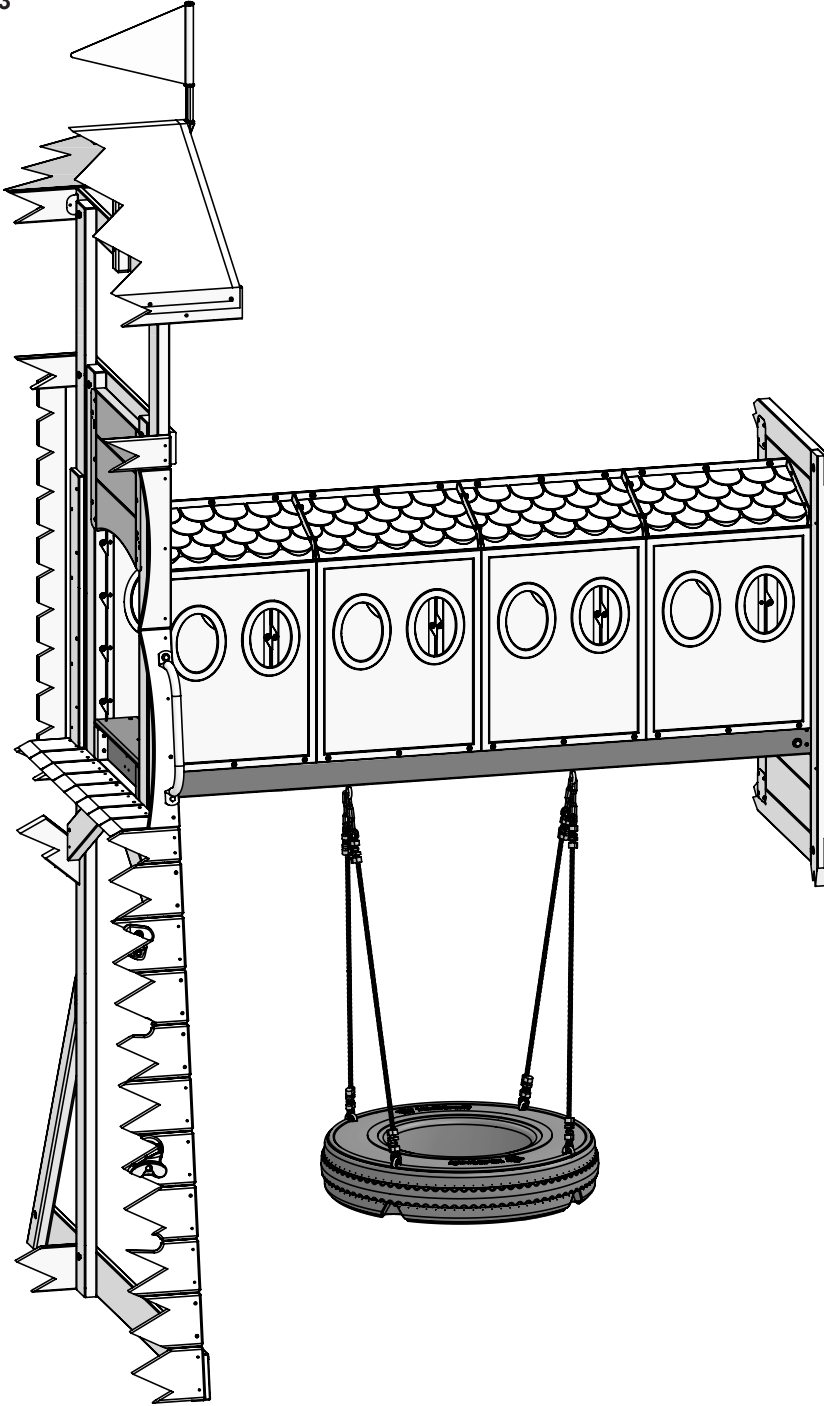


Fig. 66.4

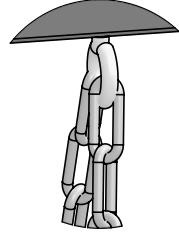
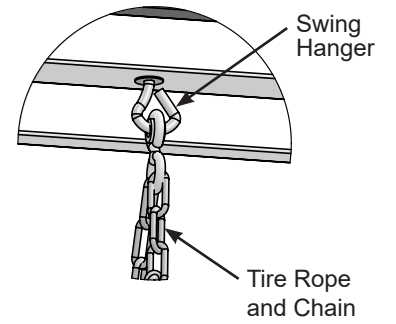


Fig. 66.5



# Step 67: Install Ground Stakes



**A:** In the 4 places shown in (fig. 67.2) drive the Rebar Ground Stakes 13" (330mm) into the ground against the boards. Be careful not to hit the washer while hammering stakes into the ground as this could cause the washer to break off.

**B:** Attach 1 ground stake to each (6026) Rock Rail, the (6002) Long Post and to (0369) Lower Diagonal using 1 (S7) #12 x 2" Pan Screw per ground stake as shown in (fig. 67.1 & 67.2)

**C:** After driving stakes into the ground, check for sharp edges caused by the impact of the hammer. Smooth any sharp edges from impact area and touch up with outdoor paint.

**⚠ Warning!** To prevent tipping and avoid potential injury, stakes must be driven 13" (330mm) into ground. Digging or driving stakes can be dangerous if you do not check first for under-ground wiring, cables or gas lines.

Fig. 67.1

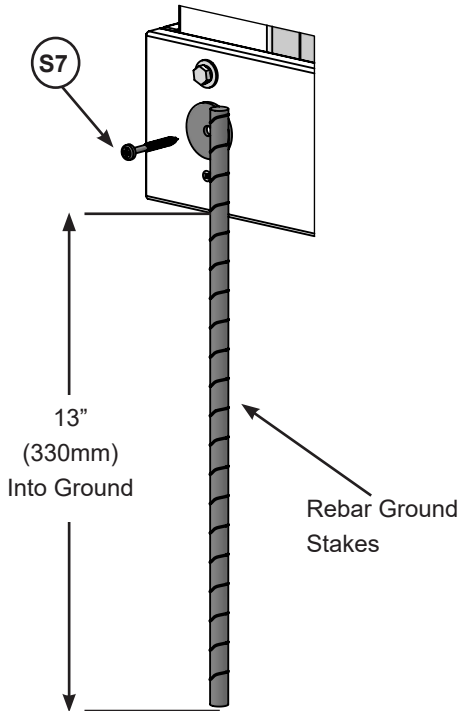
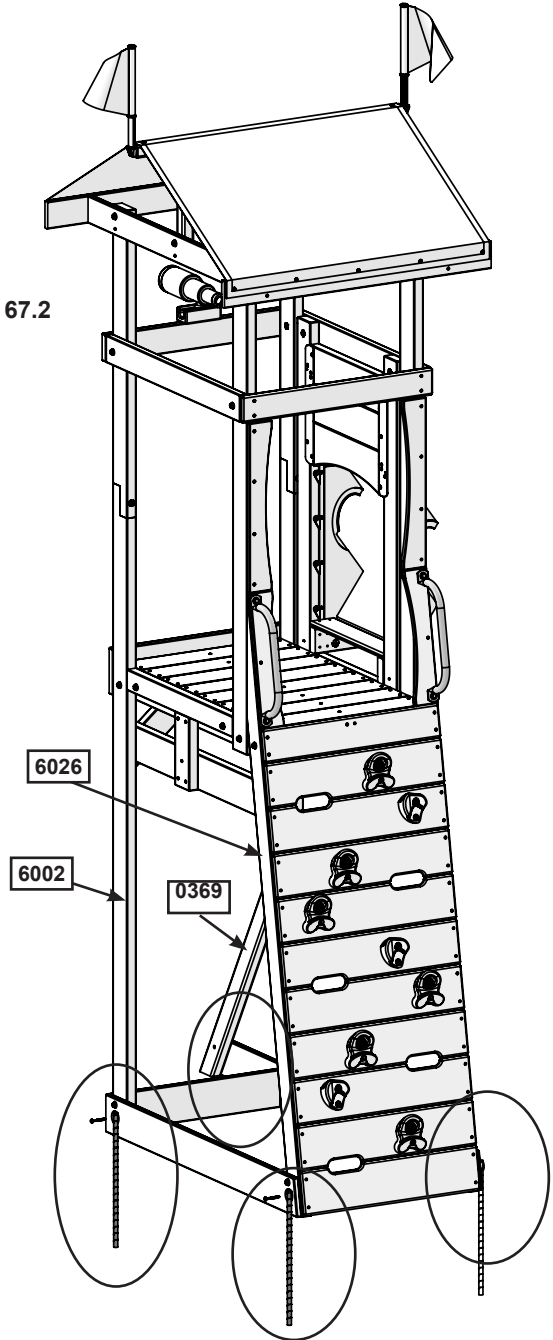


Fig. 67.2



## Hardware

4 x (S7) #12 x 2" Pan Screw

## Other Parts

4 x Rebar Ground Stake

# Adventure Tower Assembly

## Step 68: Sand and Water Table Assembly

### Part 1

**A:** Place 2 (6015) Box Legs so that the cut outs are on the outside and at the bottom. Place 1 (6004) Box Bottom across the top of the boards making sure that all top holes line up. Attach with 4 (H2) ¼ x 2" Hex Bolts (with flat washer, lock washer and t-nut) making sure that the t-nuts are installed into the Box Bottom. (Fig.68.1 & 68.2)

**B:** Fit 1 (6011) Box Side into the cut outs on each (6015) Box Leg and attach with 1 (H12) ¼ x 3" Hex Bolt (with flat washer, lock washer and t-nut) per side. (Fig.68.1 & 68.2).

**C:** From inside the frame place 1 (8832) Box End so that it's pressed up flush to both (6015) Box Legs with the pre-sunk holes at the bottom and towards the outside (Fig.68.3). Attach with 2 (H1) ¼ x 1-1/2" Hex Bolts (with flat washer, lock washer and t-nut), 2 (S15) #8 x 1-3/4" Wood Screws and 2 (S4) #8 x 3" Wood Screws as shown in (Fig.68.1 & 68.2).

Fig. 68.1

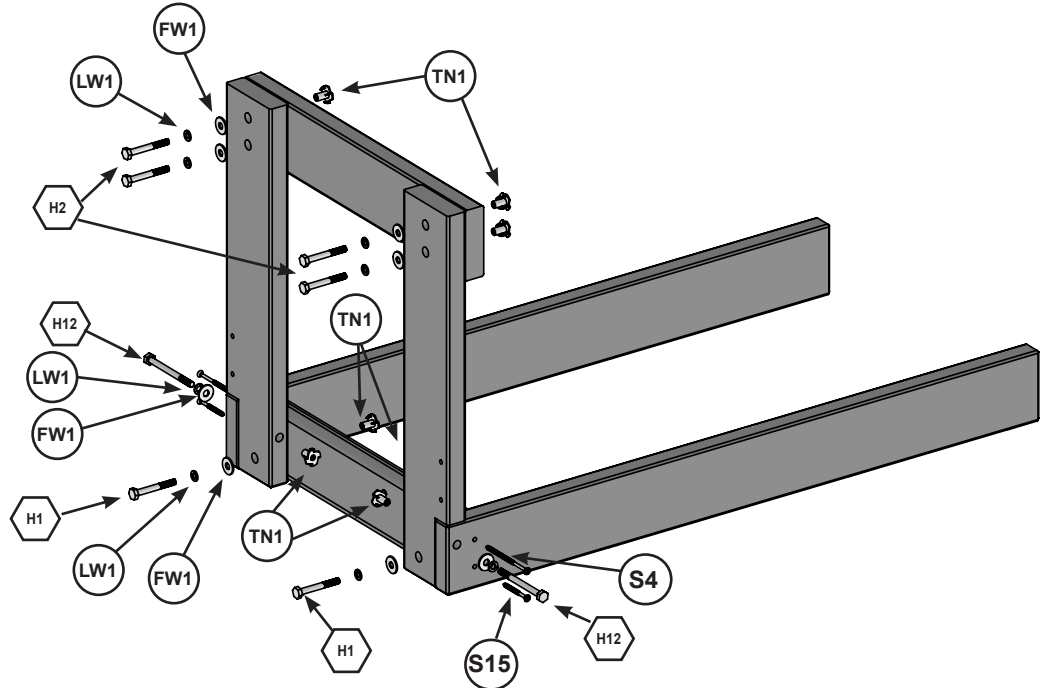
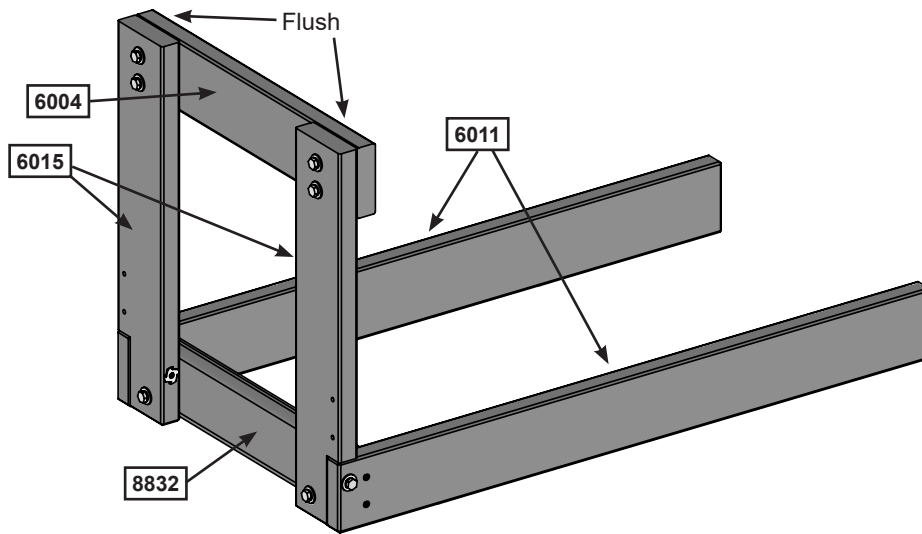


Fig. 68.2



#### Wood Parts

- 1 x **6004** Box Bottom 15/16 x 3-1/4 x 16-1/8"
- 2 x **6015** Box Leg 15/16 x 3-1/4 x 17-1/2"
- 2 x **6011** Box Side 15/16 x 3-1/4 x 30-1/4"
- 1 x **8832** Box End 15/16 x 3-1/4 x 14-1/4"

#### Hardware

- 2 x **S4** #8 x 3" Wood Screw      2 x **S15** #8 x 1-3/4" Wood Screw
- 2 x **H12** ¼ x 3" Hex Bolt (LW1, FW1, TN1)
- 2 x **H1** ¼ x 1-1/2" Hex Bolts (LW1, FW1, TN1)
- 4 x **H2** ¼ x 2" Hex Bolts (LW1, FW1, TN1)



# Step 68: Sand and Water Table Assembly Part 2

**D:** Place 1 (6027) Sand Water Support against the opposite ends of the (6011) Box Sides so that the inside pre-drilled holes line up. Attach using 4 (S4) #8 x 3" Wood Screws. (Fig.68.3 & 68.4)

**E:** Install 1 (8834) Gusset per side so that the short angle is flush to the (6015) Box Legs and the long angles are flush to the (6011) Box Sides. Attach using 1 (S15) #8 x 1-3/4" Wood Screw and 1 (S4) 8 x 3" Wood Screw per side. (Fig.68.3 & 68.4)

Fig. 68.3

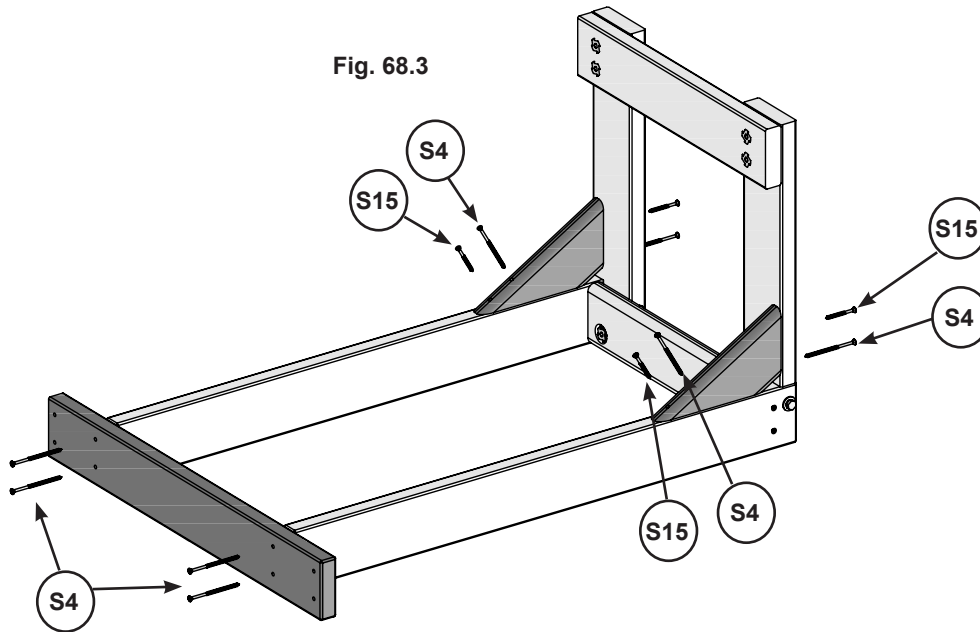
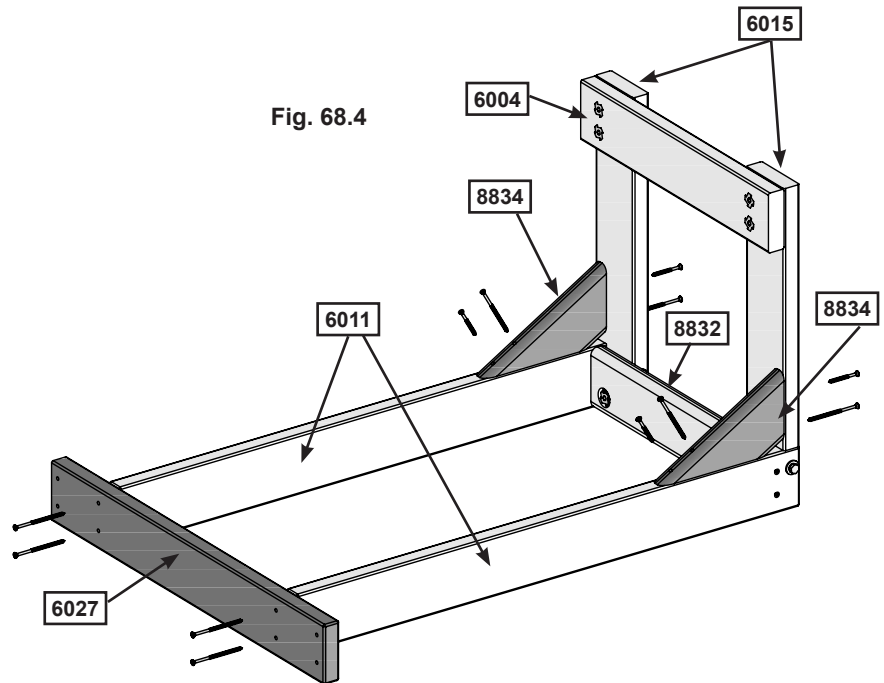


Fig. 68.4



### Wood Parts

- 1 x 6027 Sand Water Support 15/16 x 3-1/4 x 23-1/2"
- 2 x 8834 Box Gusset 15/16 x 3-1/4 x 8-1/2"

### Hardware

- 8 x S4 #8 x 3" Wood Screw
- 4 x S15 #8 x 1-3/4" Wood Screw

# Step 68: Sand and Water Table Assembly Part 3



**F:** Turn the table assembly right side up.

**G:** On the (6002) Long Posts measure 14-1/4" (362mm) up from the ground and attach the (6027) Sand and Water Supports to the (6002) Long Posts using 4 (S7) #12 x 2" Pan Screws (with 3/16" washers). (Fig.68.5 & 68.6 & 68.7).

Fig. 68.5  
right side view

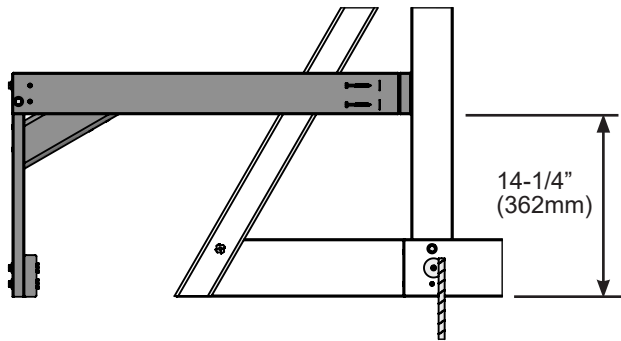


Fig. 68.6

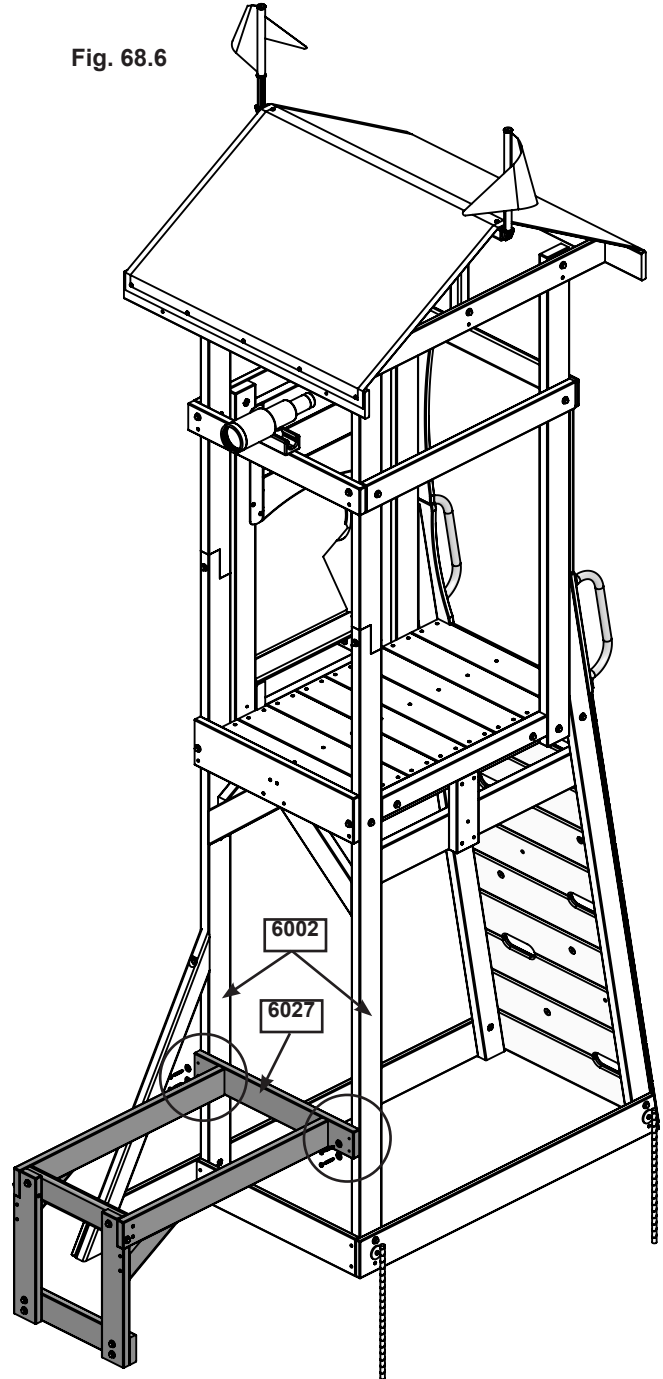
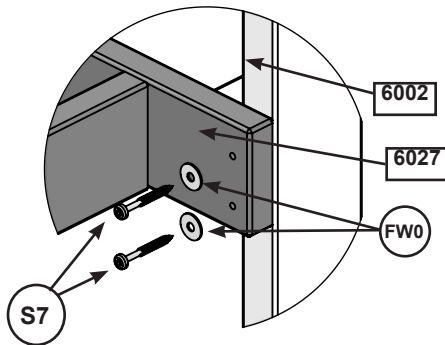


Fig. 68.7



## Hardware

4 x (S7) #12 x 2" Pan Screws (FW0)

# Step 68: Sand and Water Table Assembly Part 4

**H:** Place the Sand and Water Insert into the opening of the assembly then tighten all the bolts.

**I:** Secure the Sand and Water Insert to the assembly using 8 (S37) #7 x 5/8" Pan Screws as shown in. (Fig.68.8 & 68.9 & 68.10)

**J:** Insert plugs into the drain holes and put the shovel into the Sand and water Insert. Place the seat over the Sand and Water Insert. (fig. 68.10)

Fig. 68.8

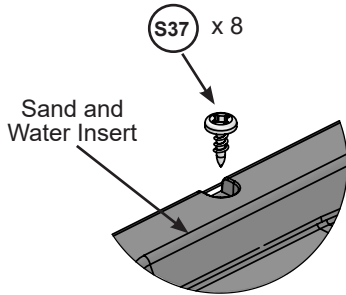


Fig. 68.9

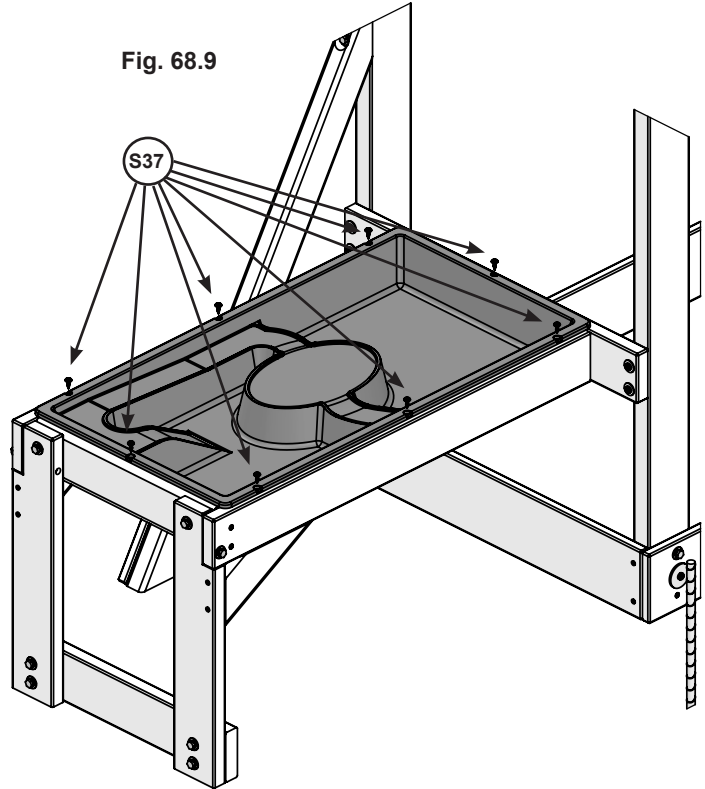
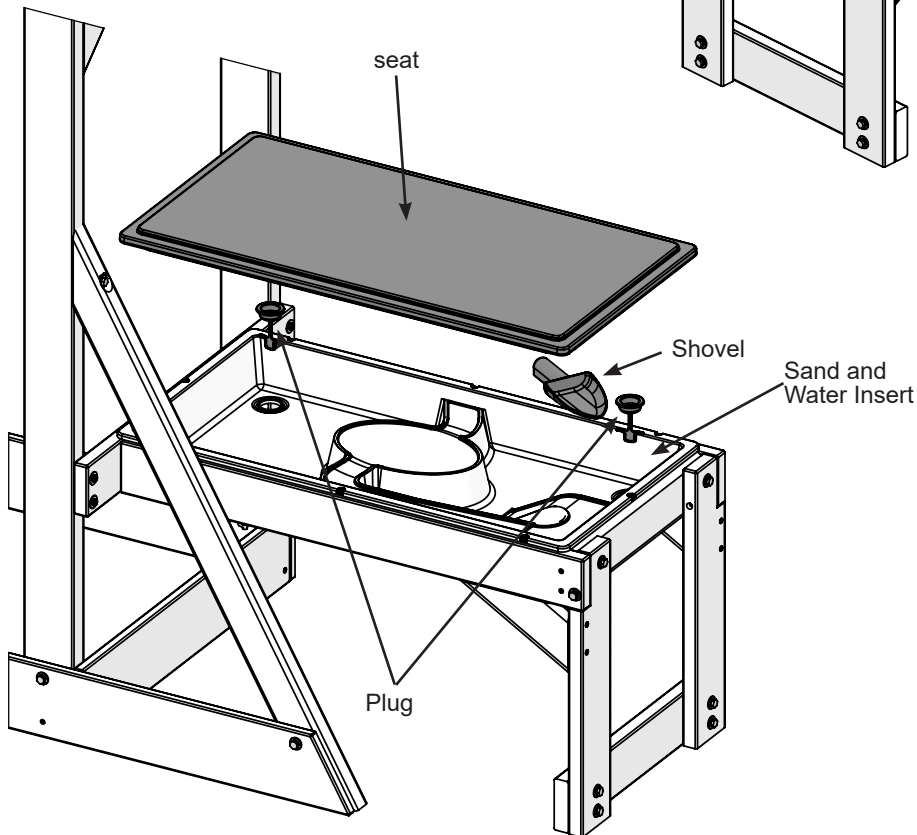


Fig. 68.10



## Hardware

8 x (S37) #7 x 5/8" Pan Screws

## Other Parts

1 x 3 in 1 Bench set ( 1 x 9320326  
2 x 9320703      1 x 93201123  
1 x 9320105 )

# Step 69: Install Window Braces



**A:** From inside the tower place 2 (6031) Window Braces side by side on each side of the Back Wall making sure that there is a 9-1/2" (241.3mm) opening in the center. Attach (6031) Window Braces using 4 (S20) #8 x 1-3/8" Wood Screws per board. (Fig. 69.1 & 69.2)

Fig. 69.1  
Back Wall

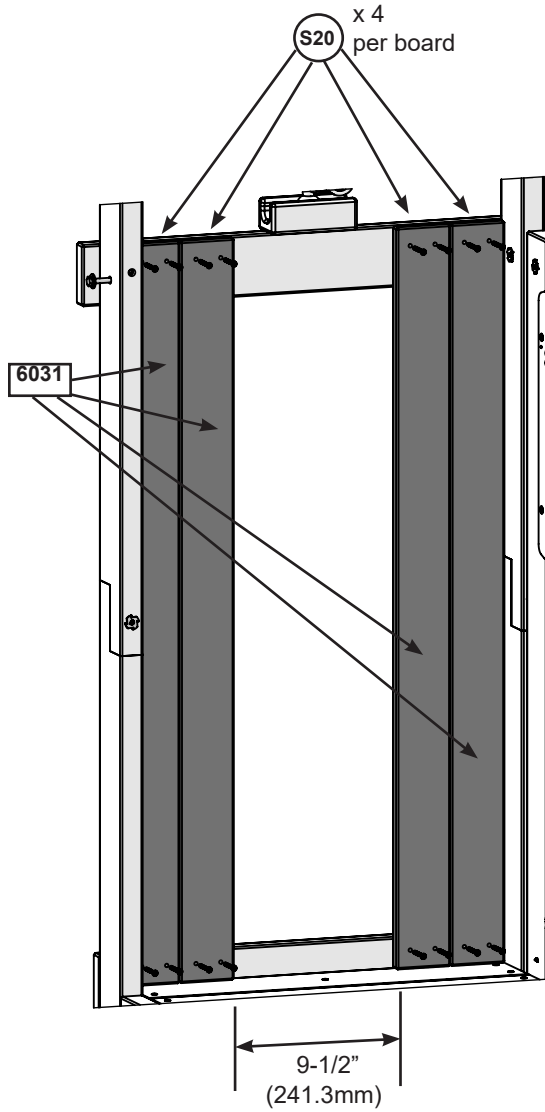
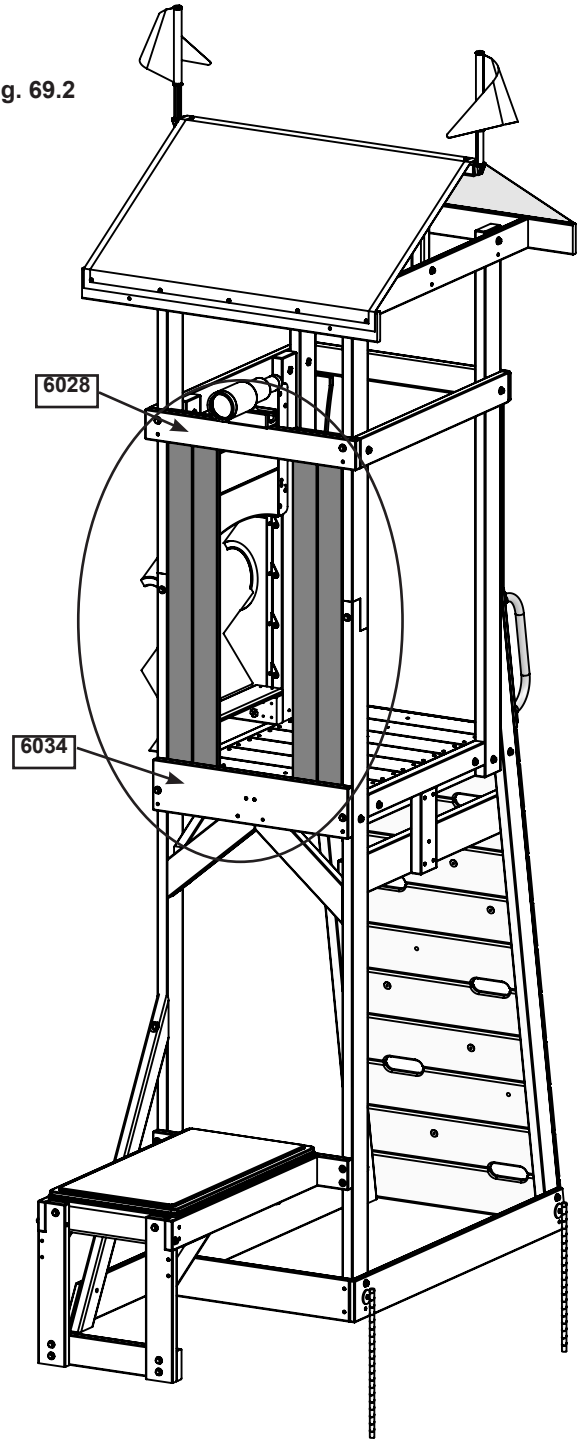


Fig. 69.2



## Wood Parts

4 x **6031** Window Brace 5/8 x 3 x 39-1/4"

## Hardware

16 x **S20** #8 x 1-3/8" Wood Screw

## Step 70: Install MOD Side Lite

**A:** From inside the assembly place the MOD Side Lite into the opening and attach to the (6031) Window Braces using 10 (S37) #7 x 5/8" Pan Screws. (Fig. 70.1 & 70.2)

Fig. 70.1  
Inside view

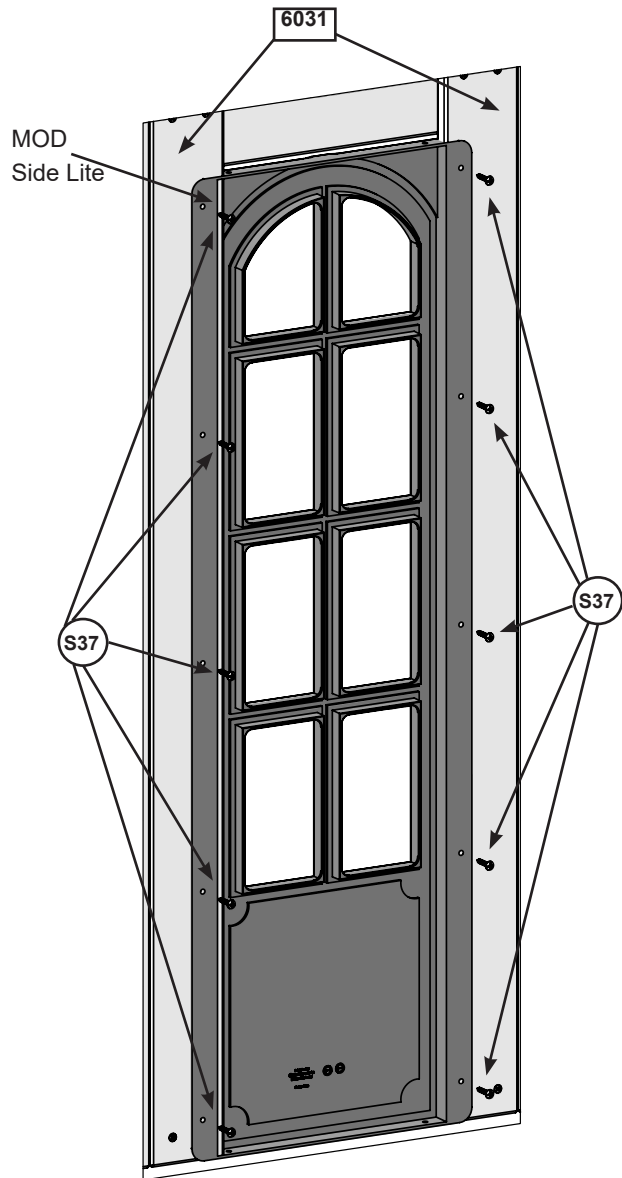
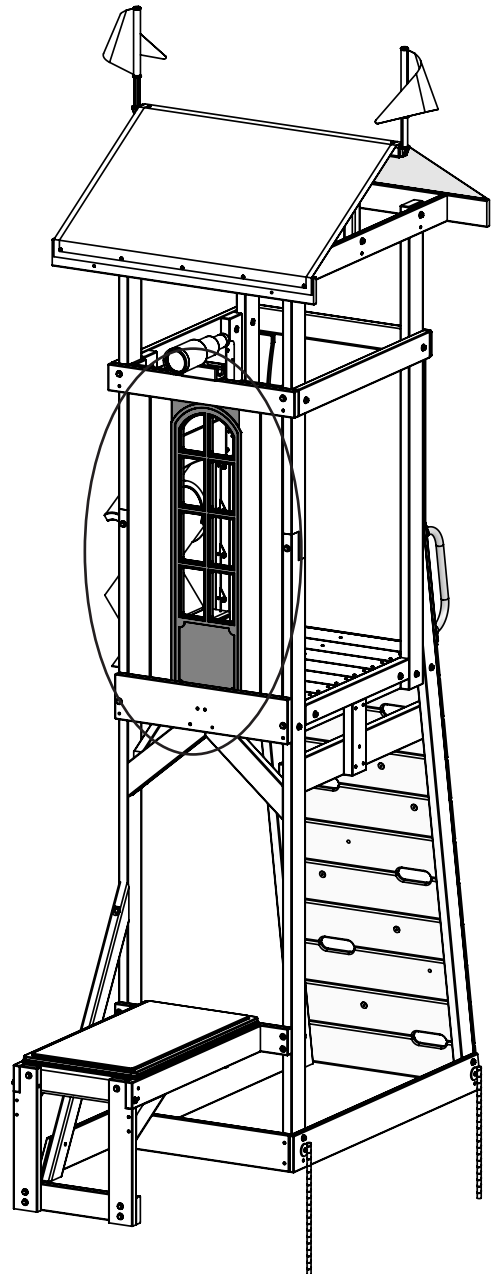


Fig. 70.2



**Note: Do NOT use top/bottom screw hole to attach window, sides only.**

### Hardware

10 x  #7 x 5/8" Pan Screw

### Other Parts

1 x 9320116

# Step 71: Attach SL Insert

**A:** From inside the assembly place the (8935) Lower SL Insert so that the narrow board is at the bottom. Make sure that it's flush with (6029) Side Top and attach using 4 (S0) #8 x 7/8" Truss Screws. (Fig. 71.1 & 71.2)

Fig. 71.1  
Inside view  
Note board  
orientation

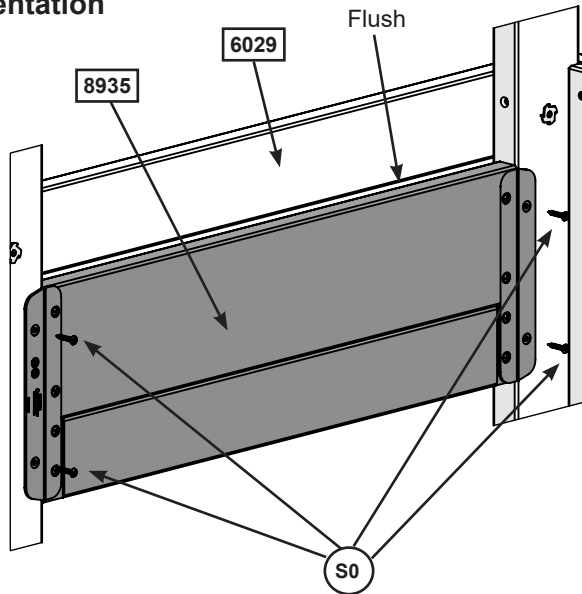
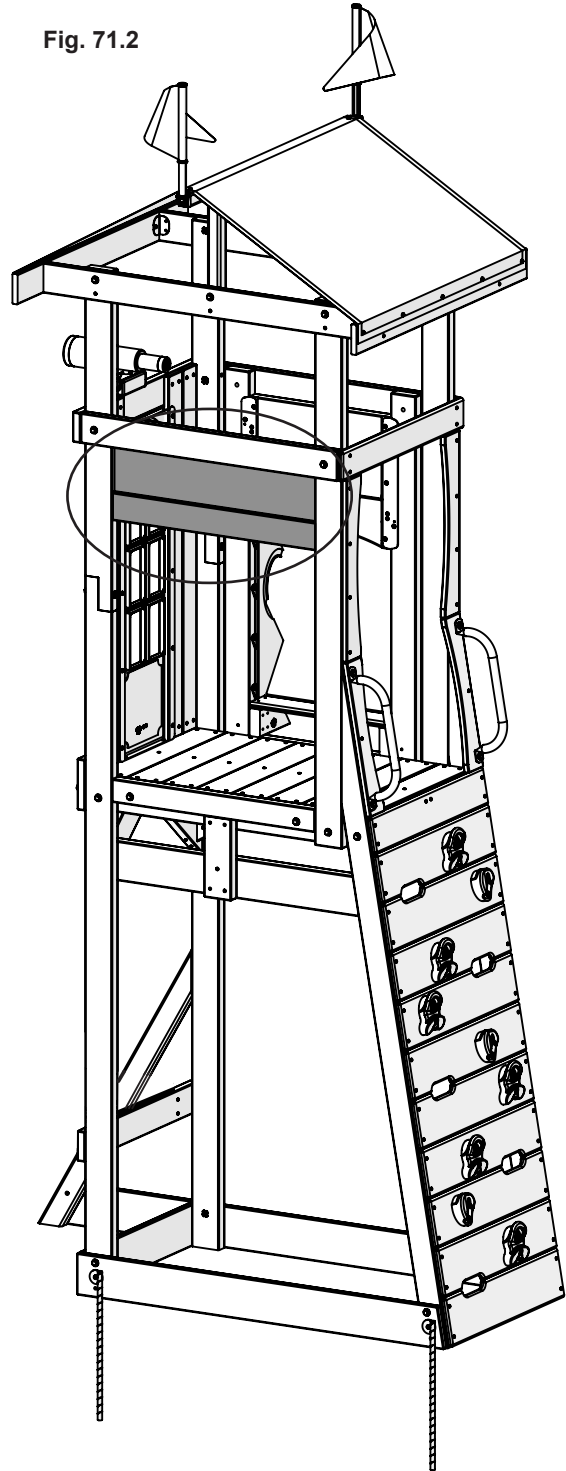


Fig. 71.2



## Wood Parts

1 x **8935** Lower SL Insert 1-1/4 x 8-1/8 x 26-1/4"

## Hardware

4 x **S0** #8 x 7/8" Truss Screws

## Step 72: Install Post Supports

**A:** From inside the tower place 1 (6033) Post Support against the far side of the left and right walls and flush to the (6031) Window Brace as shown in (Fig. 72.1 & 72.2) . Attach (6033) Post Supports to (6012) Short Posts and (6002) Long Posts using 7 (S15) #8 x 1-3/4" Wood Screws. (Fig. 72.1 & 72.2)

Fig. 72.1

**Do Not** install screw on the slide side that would hit the flange on the Lower SL Insert

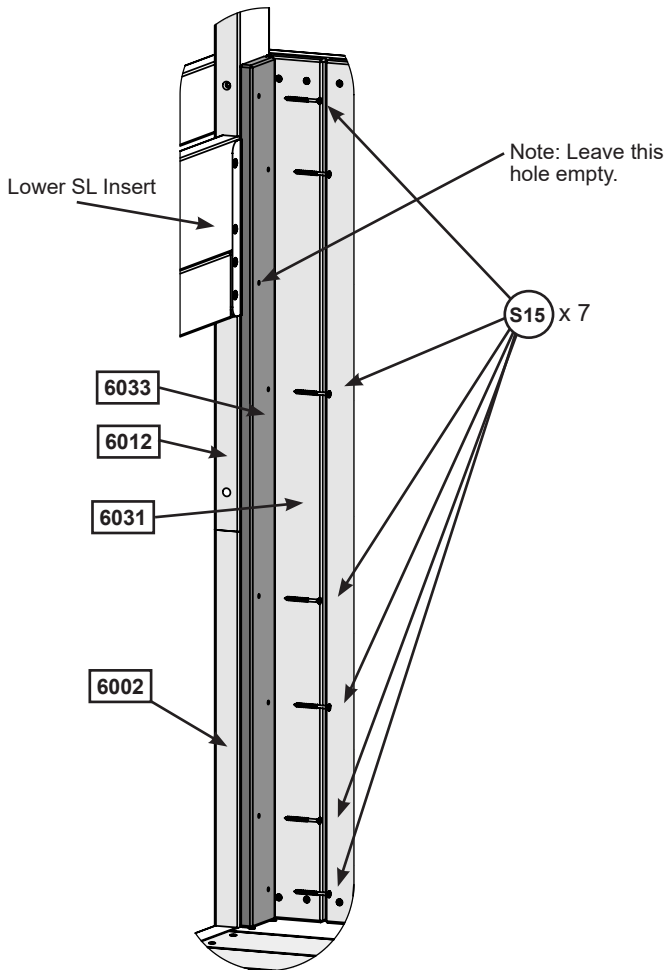
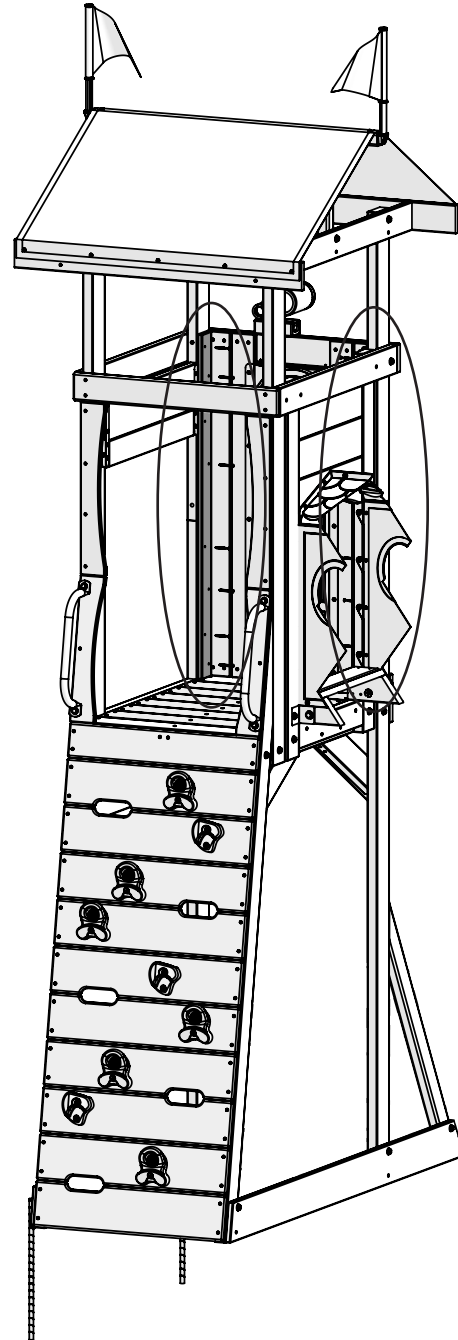


Fig. 72.2



### Wood Parts

2 x **6033** Post Support 5/8 x 2-1/2 x 39-1/4"

### Hardware

14 x **S15** #8 x 1-3/4" Wood Screws

# Step 73: Slide Section Assemblies Part 1



**Note:** When installing Pan Bolts make sure to look at holes so bolts go through the side with the round recess and the lock nuts go through the side with the hexagonal recess. (Fig. 73.3).

**A:** Fit 2 TNR2 Slide Elbows together and attach with 8 (PB1) 1/4 x 3/4" Pan Bolts (with lock nut) as shown in (Fig. 73.1). It is very important to attach bolts as indicated.

**B:** Repeat Step A 3 more times to create 4 Elbow Sections in total.

**C:** Attach TNR3 Extend Flange RT and TNR3 Extend Flange LT together using 9 (PB1) 1/4 x 3/4" Pan Bolts (with lock nut) as shown in (Fig. 73.2). This creates the Flange Assembly.

Fig. 73.1

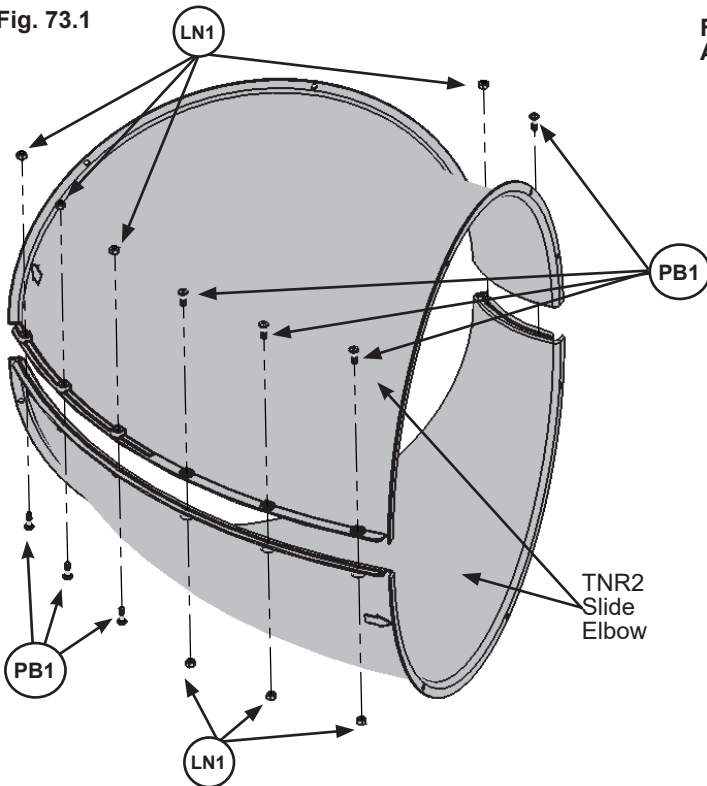


Fig. 73.2  
Flange Assembly

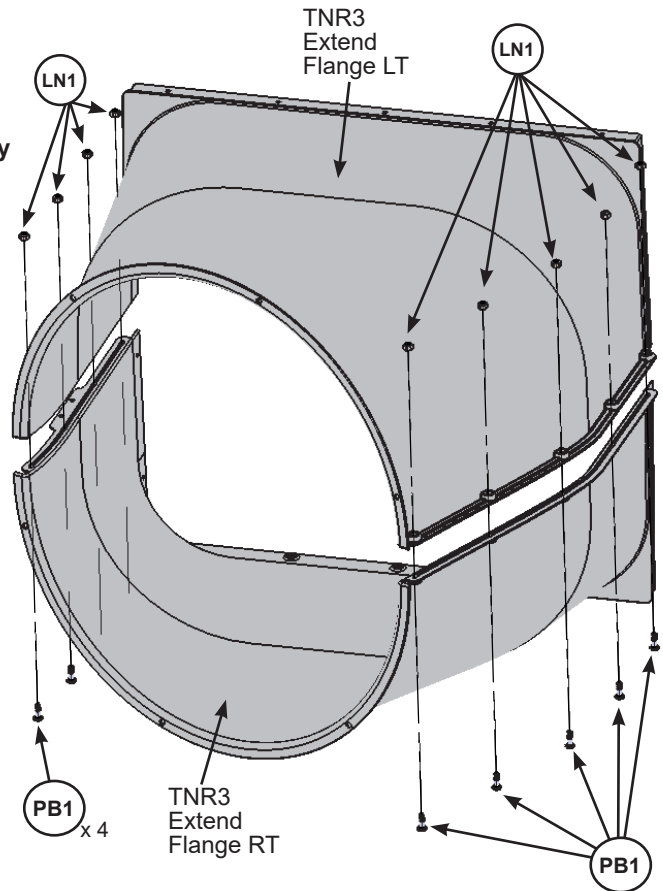
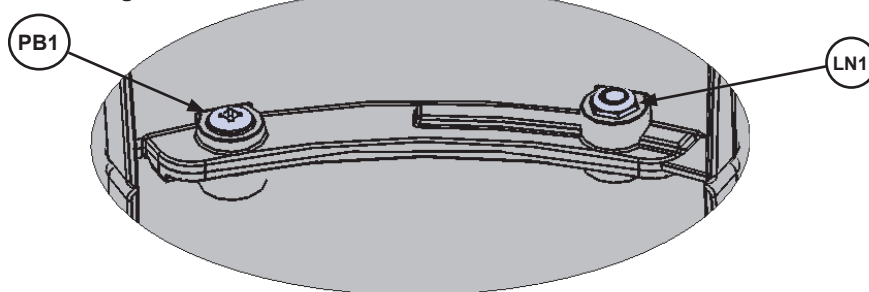


Fig. 73.3



Use a 7/16" open end wrench for nuts

### Hardware

41 x (PB1) 1/4 x 3/4" Pan Bolt (LN1)

### Other Parts

1 x TNR3 Extend Flange RT  
1 x TNR3 Extend Flange LT  
8 x TNR2 Slide Elbow



# Step 73: Slide Section Assemblies Part 2

**Note:** When installing Pan Bolts make sure to look at holes so bolts go through the side with the round recess and the lock nuts go through the side with the hexagonal recess. (Fig. 73.3)

**D:** Attach TNR2 Slide Exit Top and the remaining TNR2 Slide Elbow together using 8 (PB1) 1/4 x 3/4" Pan Bolts (with lock nut) as shown in (Fig. 73.4). It is very important to attach bolts as indicated. This creates the Exit Elbow Assembly.

Fig. 73.4

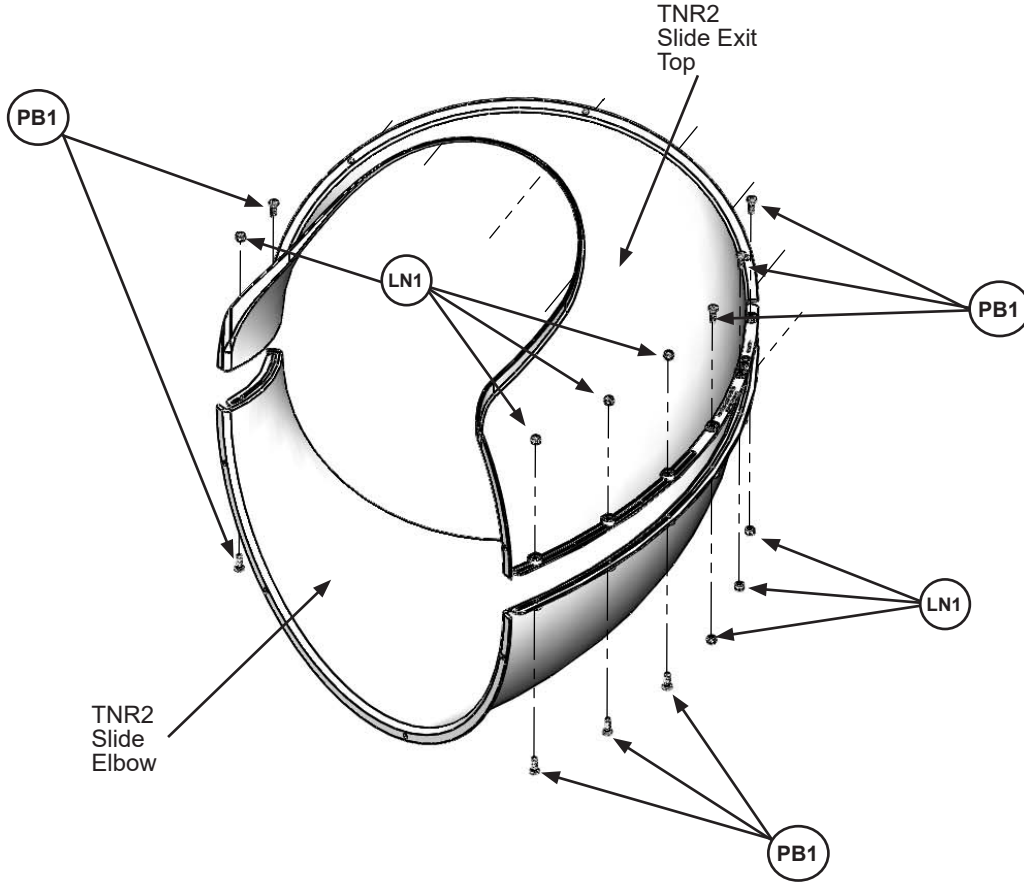
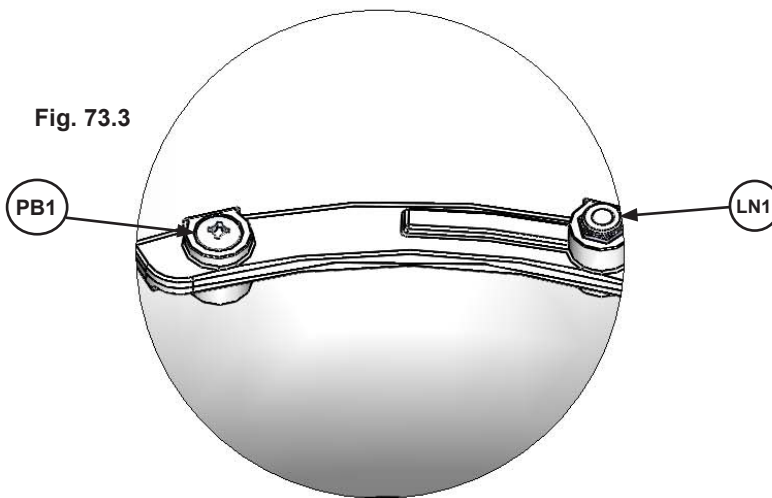



Fig. 73.3



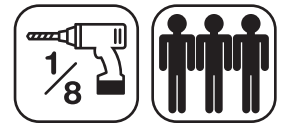
### Hardware

8 x  1/4 x 3/4" Pan Bolt (LN1)

### Other Parts

1 x TNR2 Slide Exit Top  
1 x TNR2 Slide Elbow

# Step 74: Attach Flange Assembly to Adventure Tower Part 1

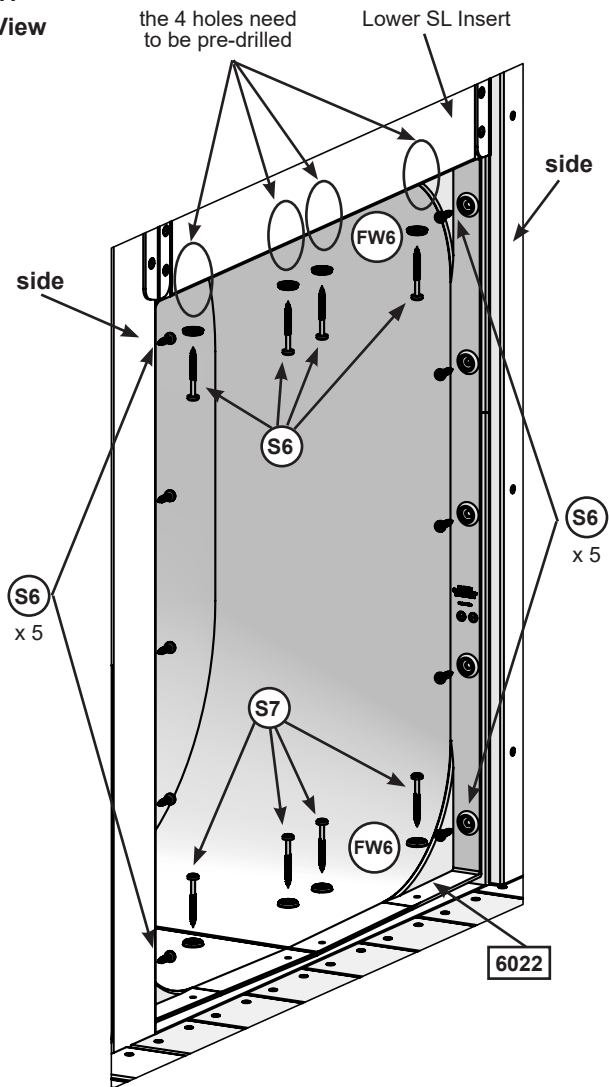


**A:** With a helper place the Flange Assembly flush to Slide Wall as shown in (Fig. 74.2), then attach Flange Assembly to the (6022) SL Brace using 4 (S7) #12 x 2" Pan Screws (with #12 Screw Bezel) (Fig. 74.1) Make sure the flat surfaces of the Flange Assembly are flush to the side wall as shown in (Fig. 74.2)

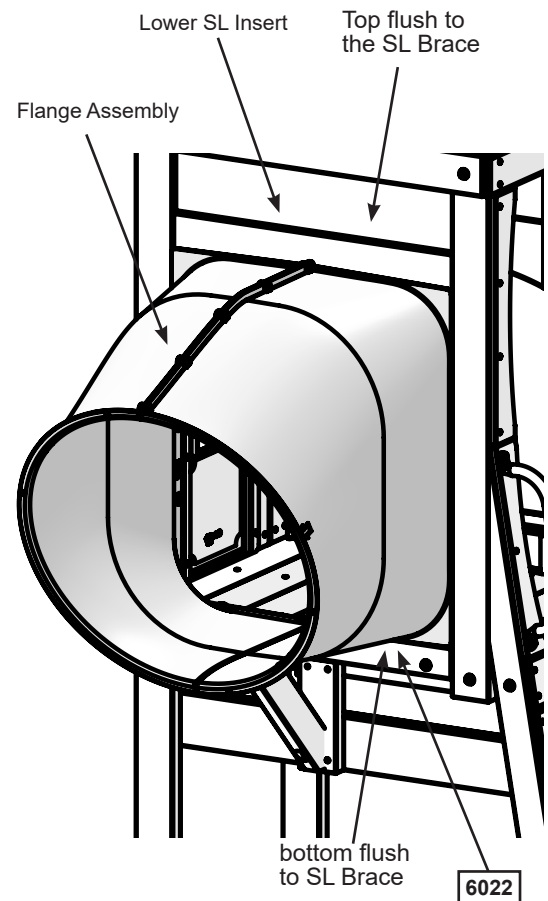
**B:** Pre-drill 1/8" (3.2mm) pilot holes in the mounting locations on Lower SL Insert (approximate spots where circles are on figure), making sure the pre-drilled holes are a minimum of 1" (25.4mm) deep. (Fig. 74.1)

**C:** Attach the Flange Assembly flush to Lower SL Insert using 4 (S6) #12 x 1" Pan Screws (with #12 Screw Bezel) in the pre-drilled holes as shown in (Fig. 74.1) and to both left and right sides using 5 (S6) #12 x 1" Pan Screw per side. (Fig. 74.1)




**Fig. 74.1  
Inside View**



**Fig. 74.2  
Outside View**



**Hardware**

- 14 x  #12 x 1" Pan Screw
- 4 x  #12 x 2" Pan Screw
- 8 x  #12 Screw Bezel

# Step 74: Attach Flange Assembly to Adventure Tower Part 2



**D:** Place (8934) SL Gusset centered and tight to (6005) Slide Block and attach to Flange Assembly with 2 (S6) #12 x 1" Pan Screws. (Fig. 74.3 & 74.4)

**E:** Pre-drill pilot hole with a 3/16" (4.8mm) drill bit then attach (8934) SL Gusset to (6005) Slide Block with 1 (WL5) 1/4 x 2-1/2" Wafer Lag (with flat washer). (Fig. 74.3 & 74.4)

Fig. 74.3

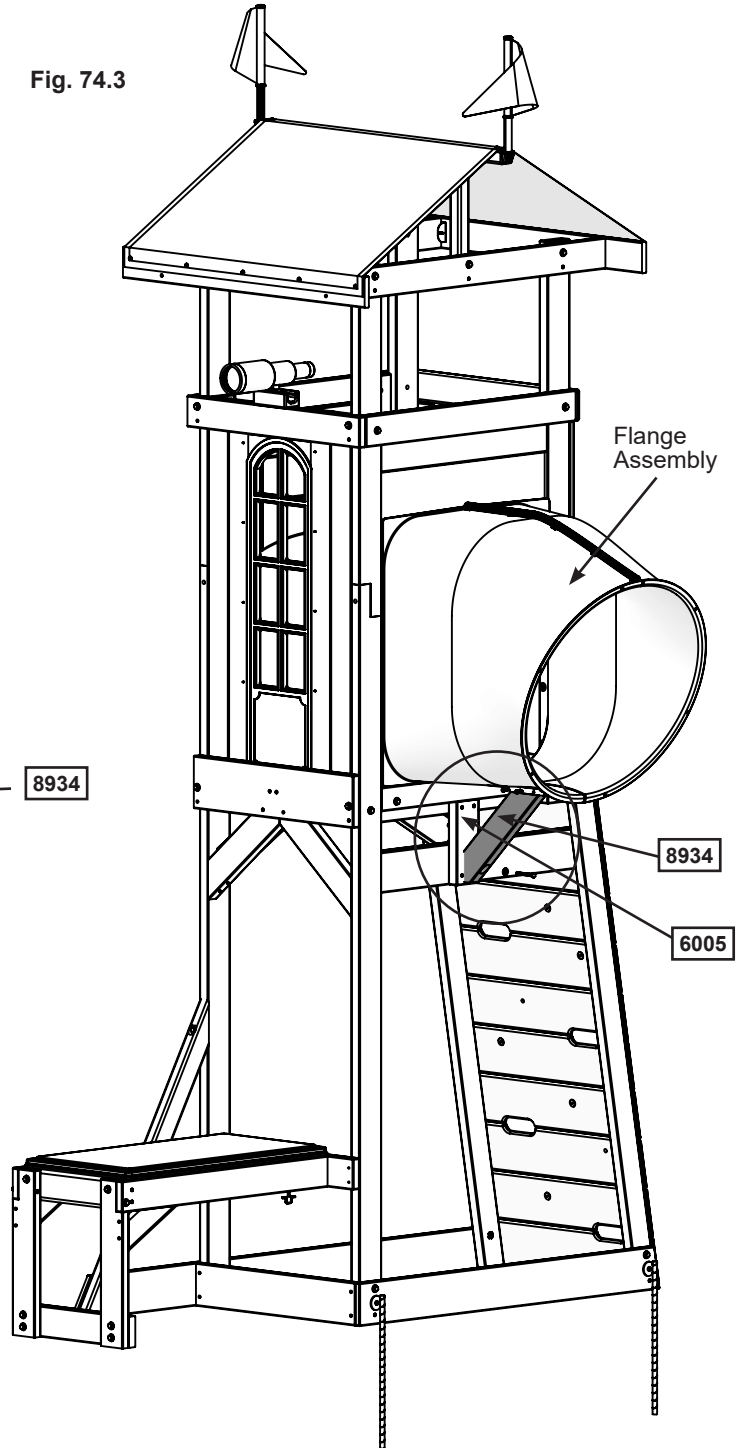
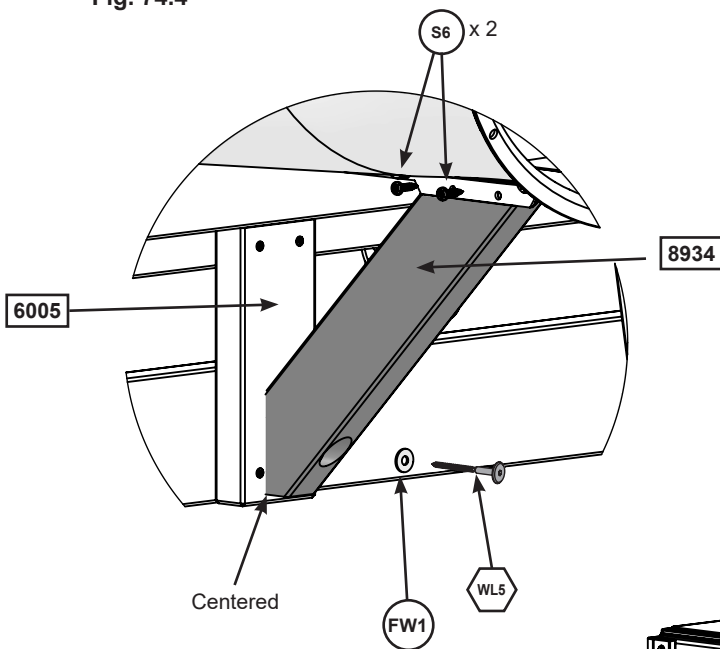


Fig. 74.4



## Wood Parts

1 x 8934 SL Gusset 1-1/4 x 3 x 15-3/4"

## Hardware

2 x S6 #12 x 1" Pan Screws

1 x WL5 1/4 x 2-1/2" Wafer Lag (FW1)

# Step 75: Attach Elbow Assembly to Flange Assembly Part 1



**Note:** When installing Pan Bolts make sure to look at holes so bolts go through the side with the round recess and the lock nuts go through the side with the hexagonal recess. Keep all bolts loose until further step.

**A:** Fit one of the Elbow Assemblies to the Flange Assembly by lining up the arrows on each assembly. (fig. 75.2 and 75.3)

**B:** Attach 1 TNR2 Slide Clamp Ring to the top of the joined Assemblies using 3 (PB1) 1/4 x 3/4" Pan Bolts (with LN1 lock nut), making sure to match the arrows up with the end of the clamp ring (where a seam will be) as shown in fig. 75.2 and 75.3.

Use Quadrex Driver as a guide pin for each hole before inserting bolt. (fig. 75.3)

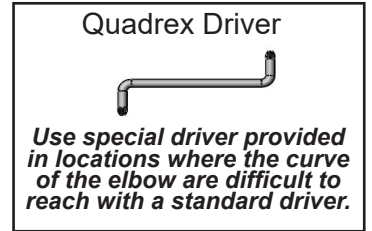


Fig. 75.1

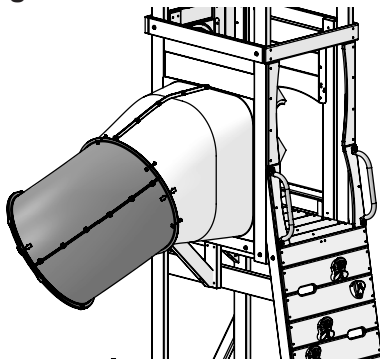
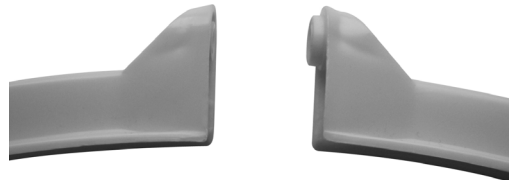
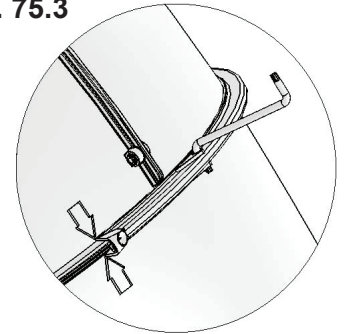


Fig. 75.4



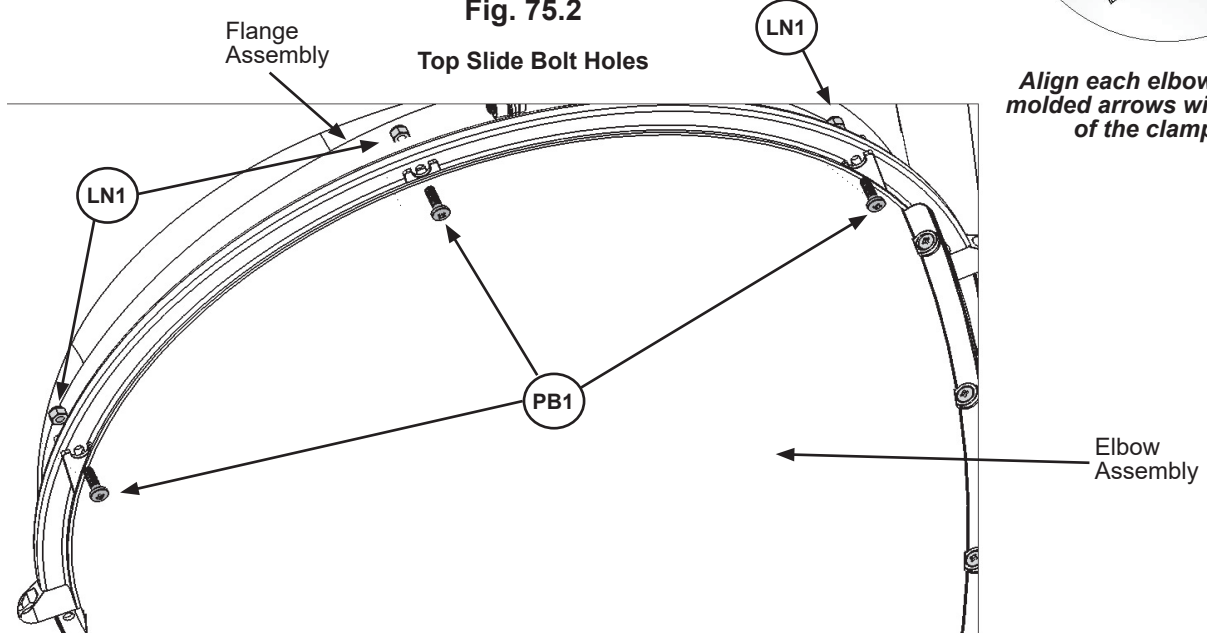
Do not install bolt in Clamp Ring ends until Step 75D

Fig. 75.3




Align each elbow using the molded arrows with the seam of the clamp ring.

Fig. 75.2



### Hardware

3 x  1/4 x 3/4" Pan Bolt (LN1 lock nut)

### Other Parts

1 x Quadrex Driver  
1 x TNR2 Slide Clamp Ring

# Step 75: Attach Elbow Assembly to Flange Assembly Part 2



**Note:** When installing Pan Bolts make sure to look at holes so bolts go through the side with the round recess and the lock nuts go through the side with the hexagonal recess. Keep all bolts loose until further step.

**C:** Attach 1 TNR2 Slide Clamp Ring to the bottom of the joined Assemblies using 2 (PB1) 1/4 x 3/4" Pan Bolts (with LN1 lock nut) on one side and 1 (PB1) 1/4 x 3/4" Pan Bolt (with LN1 lock nut) in the other side, making sure to match the arrows up with the end of the clamp ring (where a seam will be) as shown in fig. 75.5, 75.6 and 75.7.

**D:** Connect the 2 TNR2 Slide Clamp Rings together in 2 spots using 1 (PB1) 1/4 x 3/4" Pan Bolt (with LN1 lock nut) per hole. Make sure seams and arrows line up and then tighten all bolts. (fig. 75.8 and 75.9).

Fig. 31.5

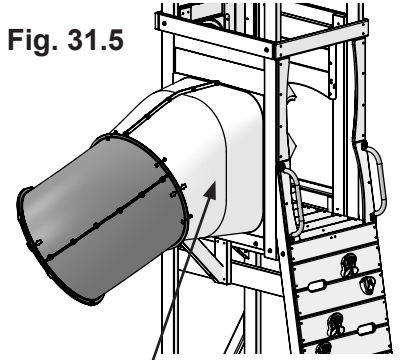


Fig. 75.6

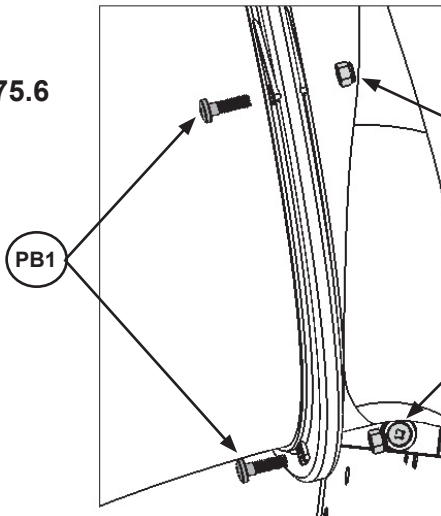


Fig. 75.7 (Side not shown)

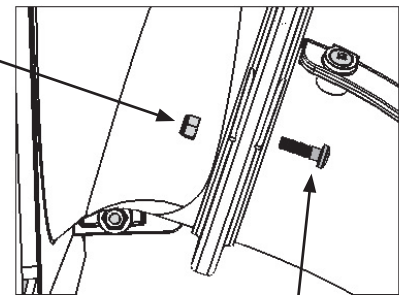


Fig. 75.8

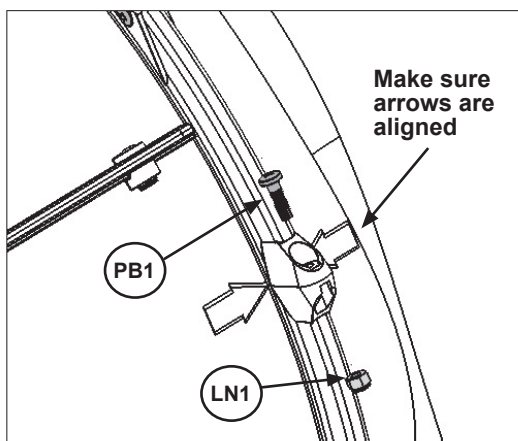
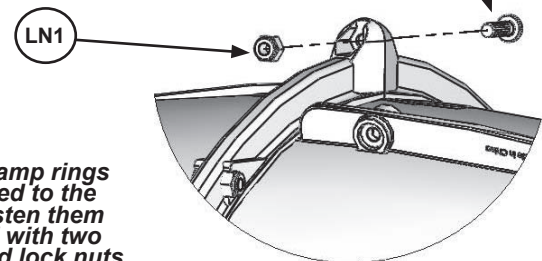


Fig. 75.9



After the clamp rings are attached to the elbows, fasten them end to end with two pan bolts and lock nuts

### Hardware

5 x (PB1) 1/4 x 3/4" Pan Bolt (LN1 lock nut)

### Other Parts

1 x TNR2 Slide Clamp Ring

# Step 76: Attach Elbow Assembly to Elbow Assembly Part 1

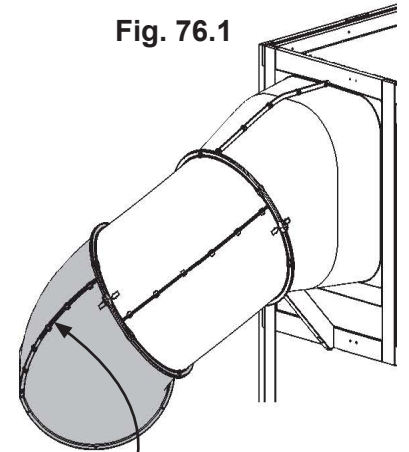


**Note:** When installing Pan Bolts make sure to look at holes so bolts go through the side with the round recess and the lock nuts go through the side with the hexagonal recess. Keep all bolts loose until further step.

**A:** Fit a second Elbow Assembly to the first Elbow Assembly by lining up the arrows on each assembly. Notice the elbow orientation. (fig. 76.1)

**B:** Attach 1 TNR2 Slide Clamp Ring to the top of the joined Assemblies using 3 (PB1) 1/4 x 3/4" Pan Bolts (with lock nut), making sure to match the arrows up with the end of the clamp ring (where a seam will be) as shown in fig. 76.2 and 76.3.

**Use Quadrex Driver as a guide pin for each hole before inserting bolt.**

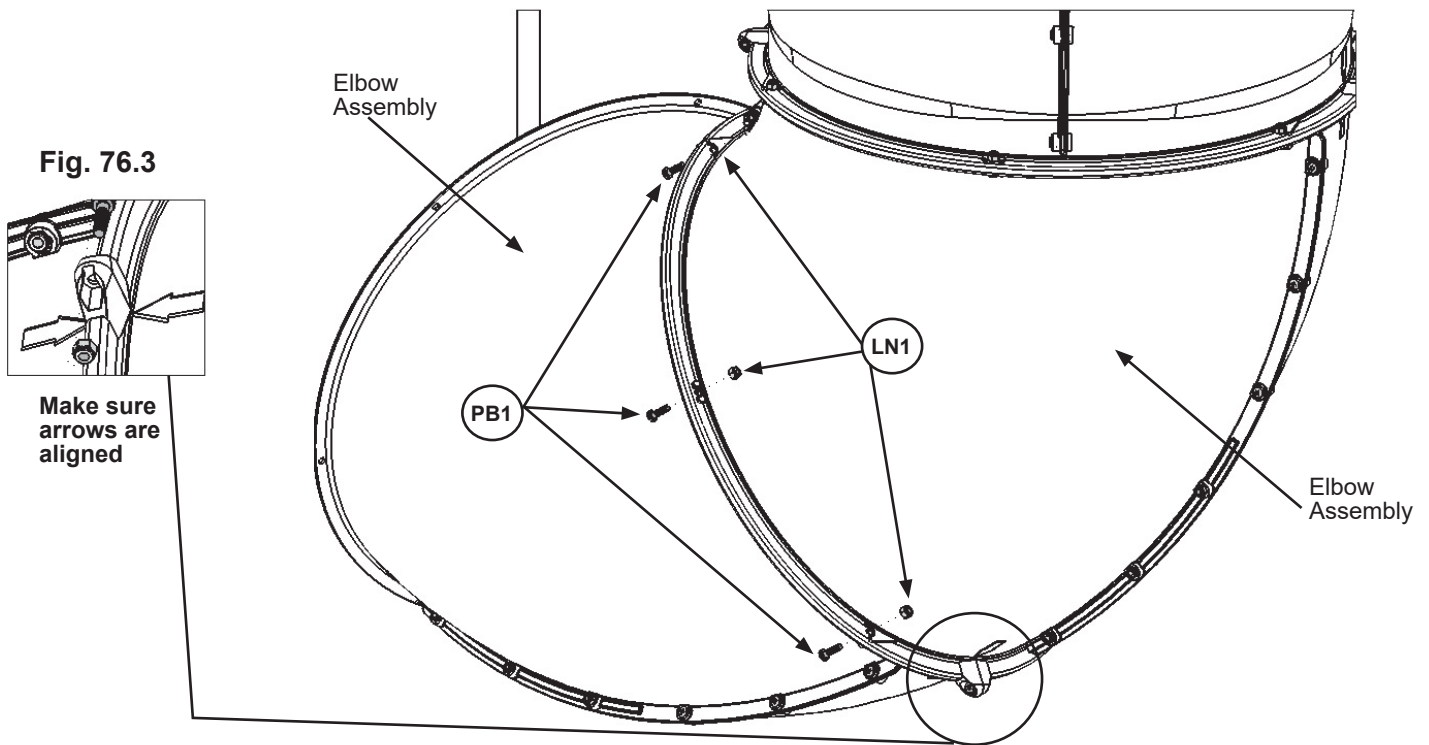


Notice elbow orientation



Do not install bolt in Clamp Ring ends until Step 76D

**Fig. 76.2**  
Top Slide Bolt Holes



**Fig. 76.3**

Make sure arrows are aligned

### Hardware

3 x **(PB1)** 1/4 x 3/4" Pan Bolt (LN1 lock nut)

### Other Parts

1 x TNR2 Slide Clamp Ring

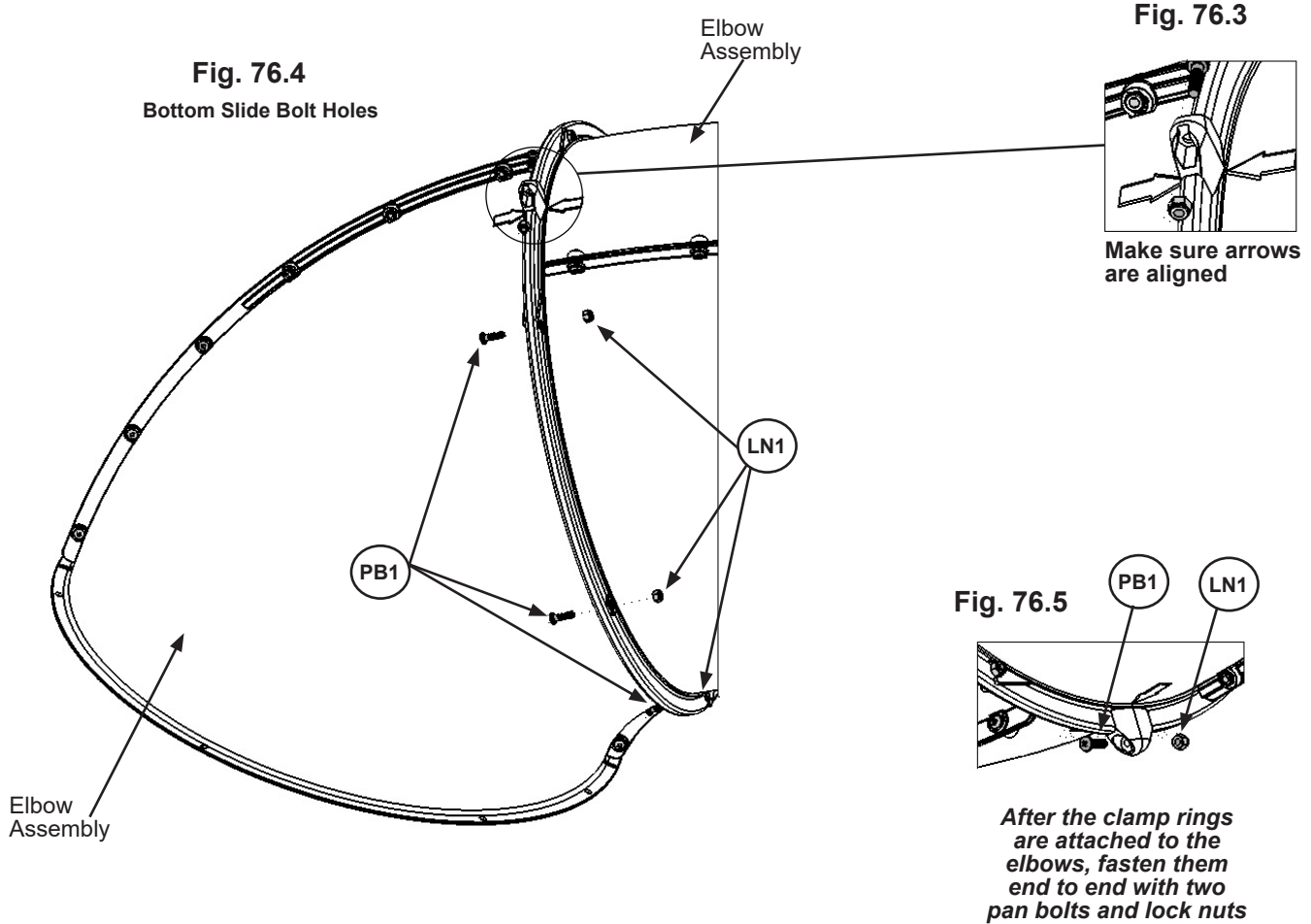
# Step 76: Attach Elbow Assembly to Elbow Assembly Part 2




**Note:** When installing Pan Bolts make sure to look at holes so bolts go through the side with the round recess and the lock nuts go through the side with the hexagonal recess. Keep all bolts loose until further step.

**C:** Attach 1 TNR2 Slide Clamp Ring to the bottom of the joined Assemblies using 3 (PB1) 1/4 x 3/4" Pan Bolts (with LN1 lock nut), making sure to match the arrows up with the end of the clamp ring (where a seam will be) as shown in fig. 76.3 and 76.4.

**D:** Connect the 2 TNR2 Slide Clamp Rings together in 2 spots using 1 (PB1) 1/4 x 3/4" Pan Bolt (with LN1 lock nut) per hole. Make sure seams and arrows line up and then tighten all bolts. (fig. 76.3 and 76.5).



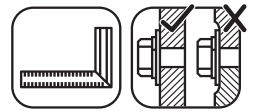
### Hardware

5 x  1/4 x 3/4" Pan Bolt (LN1 lock nut)

### Other Parts

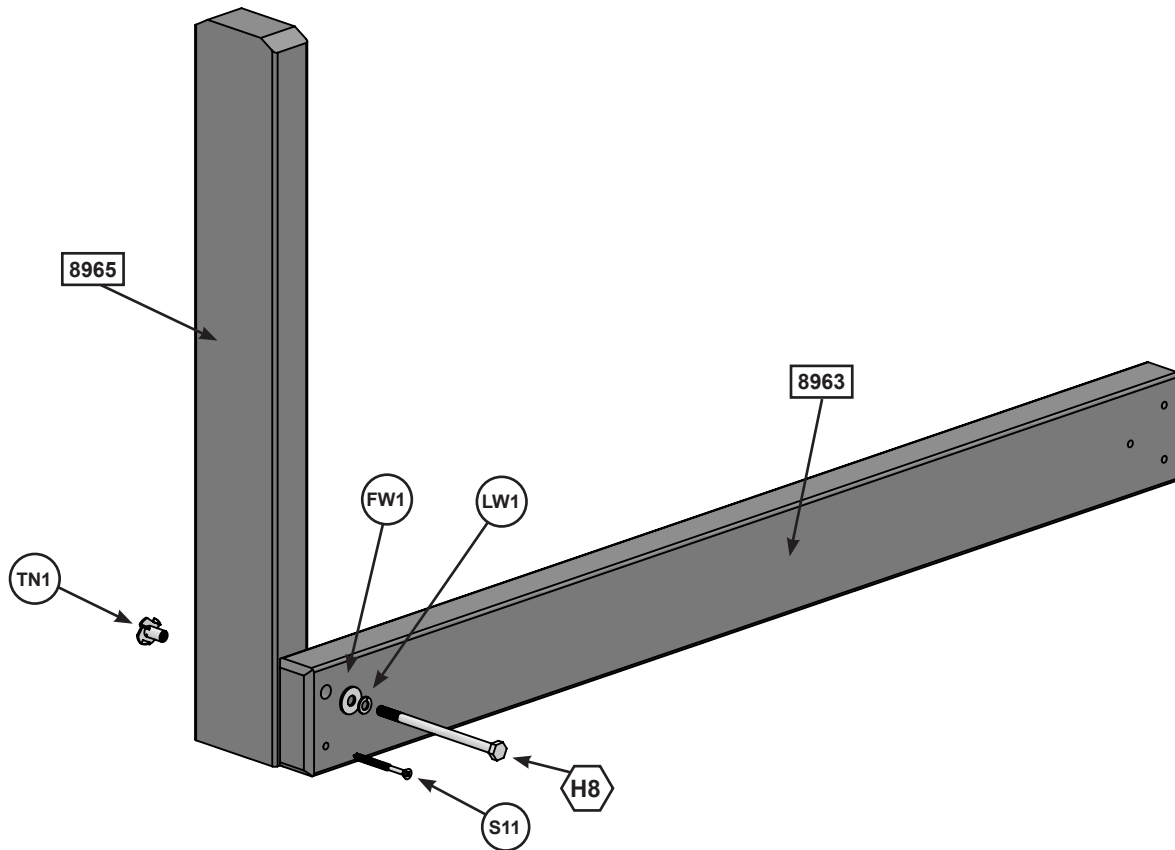
1 x TNR2 Slide Clamp Ring

# Step 77: TNR Brace Assembly





**A:** Attach (8965) TNR Upright to (8963) TNR Ground Brace with 1 (H8) 1/4 x 4-1/4" Hex Bolt (with lock washer, flat washer and t-nut) in the top hole. Make sure both boards are square then attach with 1 (S11) #8 x 2" Wood Screw. (Fig. 77.1)



Fig. 77.1



### Wood Parts

- 1 x  TNR Ground Brace 1-1/4 x 3 x 32-1/4"
- 1 x  TNR Upright 1-1/4 x 3 x 20-1/4"

### Hardware

- 1 x  #8 x 2" Wood Screw
- 1 x  1/4 x 4-1/4" Hex Bolt (LW1, FW1, TN1)



# Step 78: Attach Elbow Assemblies and TNR3 Tube Support



**Note:** When installing Pan Bolts make sure to look at holes so bolts go through the side with the round recess and the lock nuts go through the side with the hexagonal recess. Keep all bolts loose until further step.

**A:** Attach the two remaining Elbow Assemblies as instructed in Steps 75 and 76.

**B:** Place TNR Brace Assembly against (6002) Long Post so it sits under the slide. It is not attached yet. (fig. 78.1)

**C:** On the fourth Elbow Assembly attached remove the pan bolt and nut which is facing the fort (installed in Step 73). (fig. 78.1) **The bolt will no longer be needed, but keep the lock nut.**

**D:** Loosely attach TNR3 Tube Support (at the slightly bent end) to the Clamp Ring using 1 (PB6) 1/4 x 1" Pan Bolt (with FW1 flat washer and the previously removed LN1 lock nut). (fig. 78.2)

**E:** Rotate TNR3 Tube Support and attach to (6002) Long Post using 1 (S6) #12 x 1" Pan Screw as shown in fig. 78.2.

**F:** Fully tighten screw and bolt.

Remove PB1 (1/4 x 3/4" Pan Bolt) first then install PB6 (1/4 x 1" Pan Bolt with flat washer)

Fig. 78.2

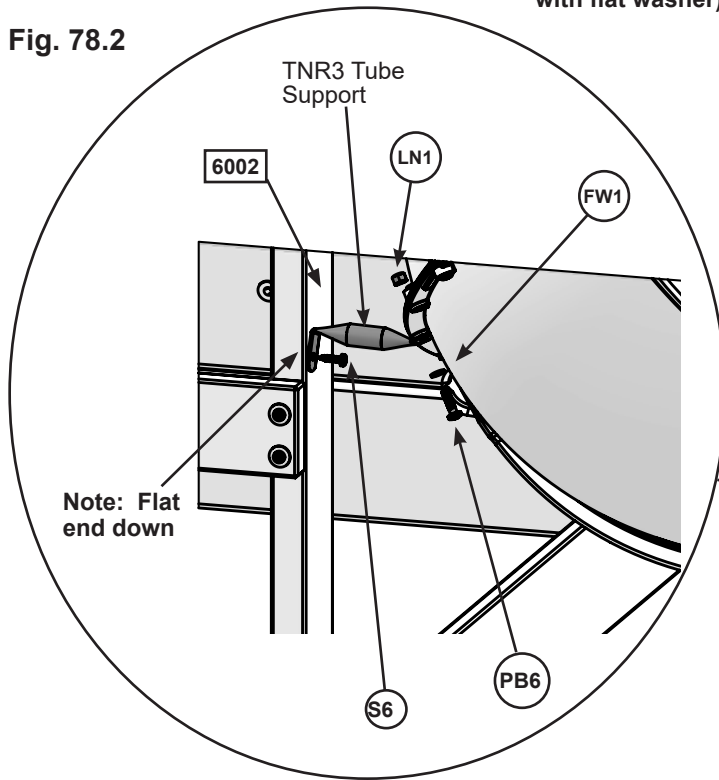
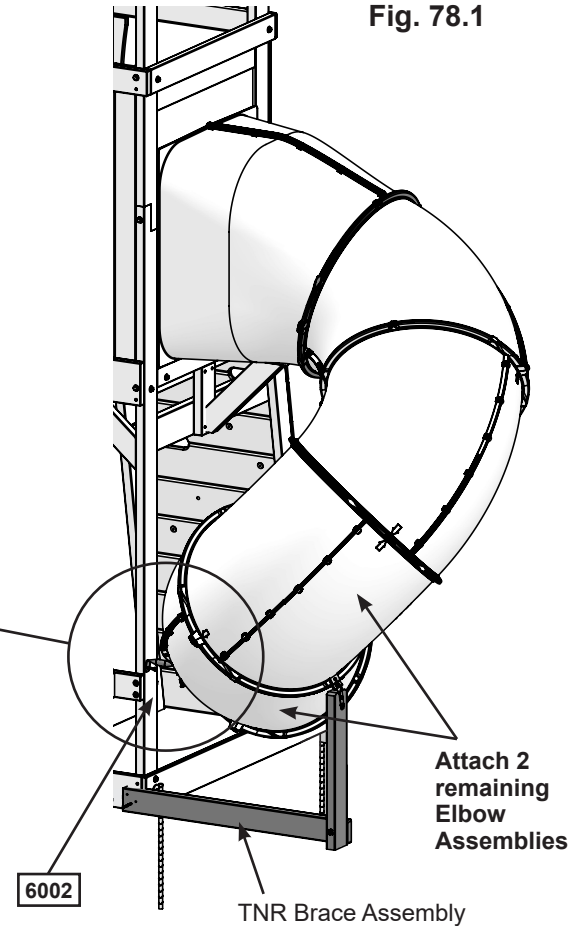


Fig. 78.1



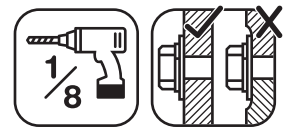
### Hardware

- 1 x (S6) #12 x 1" Pan Screw
- 1 x (PB6) 1/4 x 1" Pan Bolt (FW1 flat washer & LN1 lock nut - previously removed)
- 16 x (PB1) 1/4 x 3/4" Pan Bolt (LN1 lock nut)

### Other Parts

- 1 x TNR3 Tube Support
- 4 x TNR2 Slide Clamp Ring

# Step 79: Attach TNR Brace Assembly



**A:** Use (8965) TNR Upright as a guide to judge the proper bolt location, remove the bottom pan bolt and nut. **The bolt will no longer be needed, but keep the lock nut.** (fig. 79.1 and 79.2)

**B:** Attach the top of the TNR3 Post Mount to TNR2 Slide Clamp Ring using 1 (PB2) 1/4 x 1-1/4" Pan Bolt (with the previously removed TN1 lock nut and 1 FW1 flat washer). (fig. 79.2)

**C:** Insert TNR3 Post Mount on (8965) TNR Upright, pre-drill with a 1/8" (3.2mm) drill bit then attach with 2 (S6) #12 x 1" Pan Screws. (fig. 79.2)

**D:** Attach (8963) TNR Ground Brace flush to the bottom of (6002) Long Post with 2 (S11) #8 x 2" Wood Screws and 1 (S4) #8 x 3" Wood Screw. (fig. 79.1 and 79.3)

Fig. 79.1

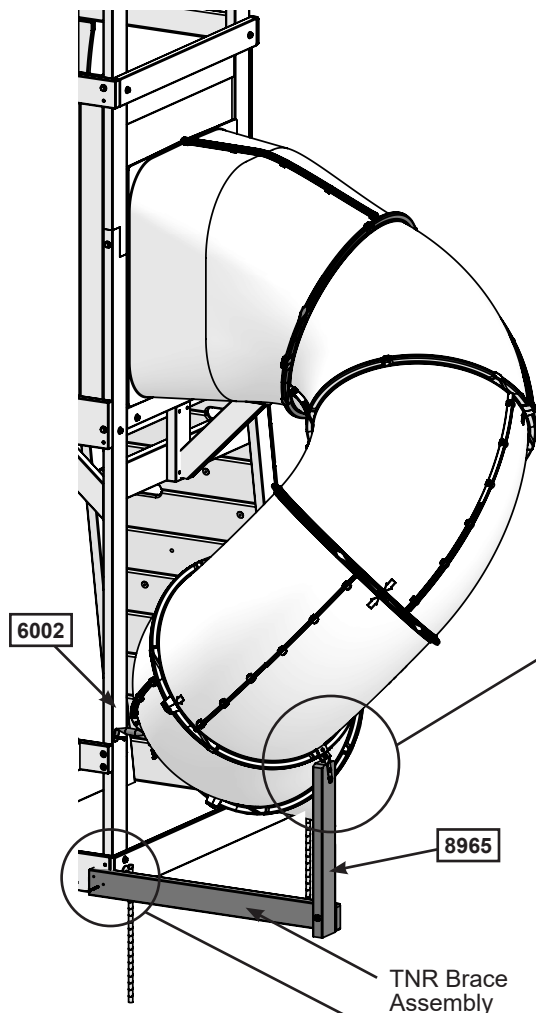


Fig. 79.2

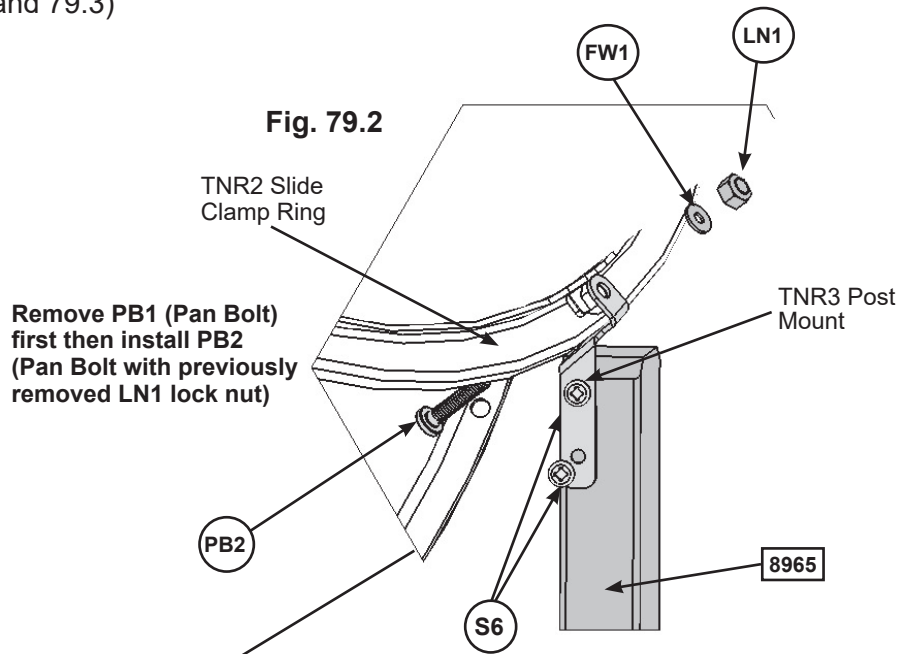
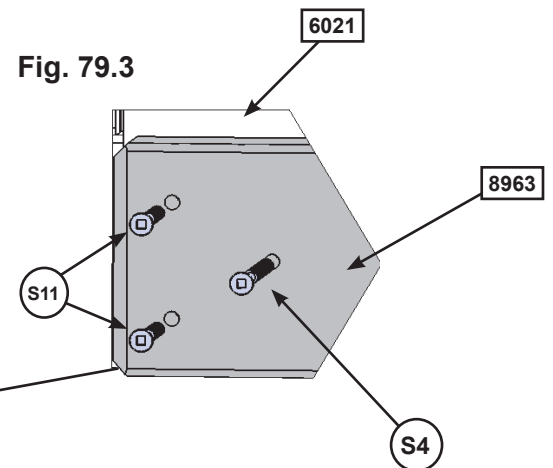


Fig. 79.3



**Hardware**

- 1 x (PB2) 1/4 x 1-1/4" Pan Bolt  
1 - (FW1 flat washer, LN1 lock nut - previously removed)
- 2 x (S6) #12 x 1" Pan Screw
- 1 x (S4) #8 x 3" Wood Screw
- 2 x (S11) #8 x 2" Wood Screw

**Other Parts**

- 1 x TNR3 Post Mount

# Step 80: Attach TNR3 Slide Exit to Exit Elbow Assembly



**A:** Insert flange of Exit Elbow Assembly (slide elbow) into the slots on TNR3 Short Exit. (fig. 80.1)

**B:** Rotate Slide Exit and use Quadrex Driver as a guide pin so the holes are aligned and attach with 5 (PB1) 1/4 x 3/4" Pan Bolts (with TN1 lock nuts) starting with the bottom middle hole and working up each side. (fig. 80.2 and 80.3)

**C:** At this point make sure all the slide bolts are tight. **Use a 7/16" (11mm) open end wrench to hold nut and then tighten bolt with Quadrex Driver on Clamp Rings.**

Fig. 80.1

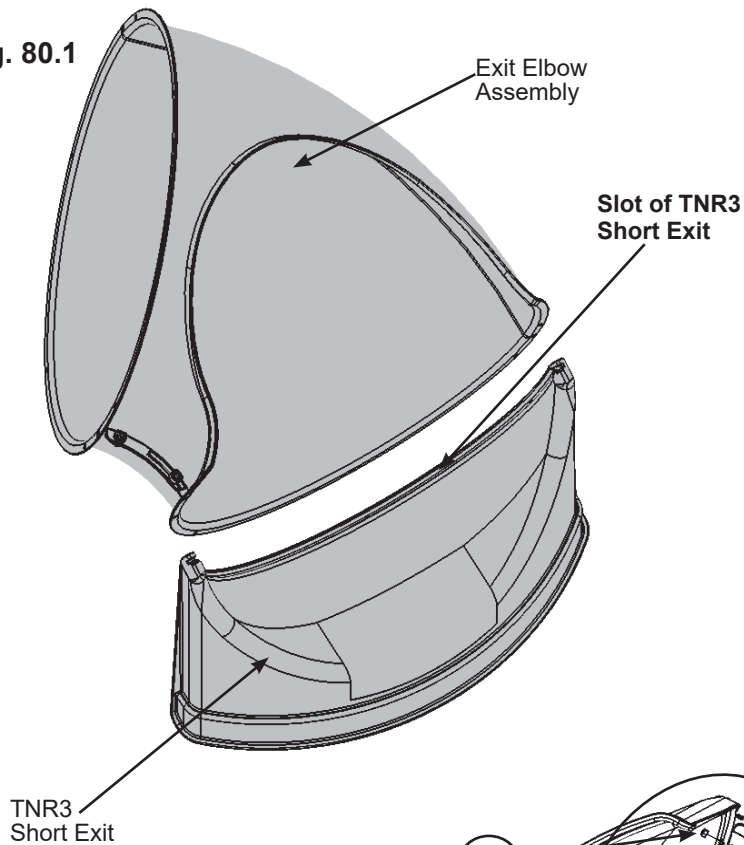


Fig. 80.3

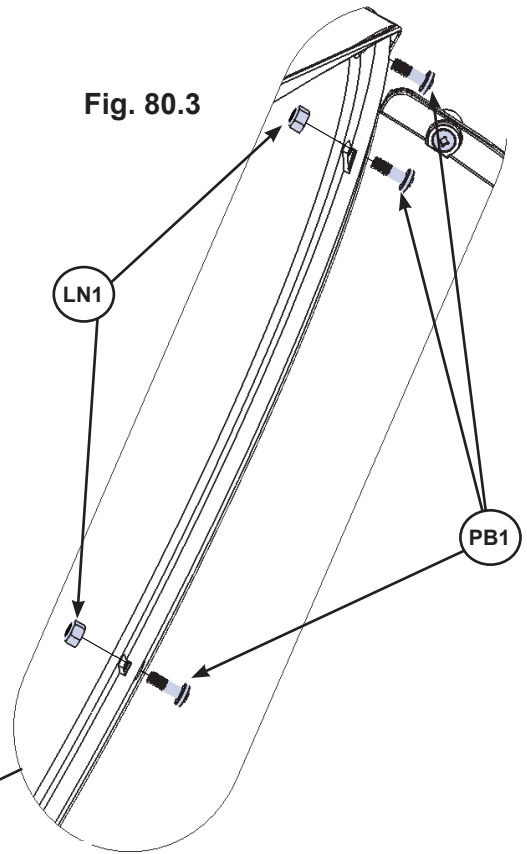
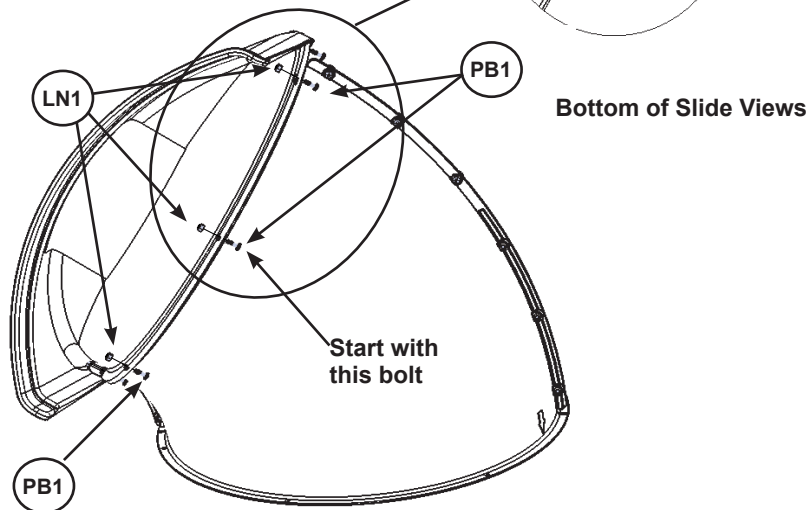



Fig. 80.2



## Hardware

5 x  1/4 x 3/4" Pan Bolt (LN1 lock nut)

## Other Parts

1 x TNR3 Short Exit

# Step 81: Attach Exit End Assembly to Fort



**Note:** When installing Pan Bolts make sure to look at holes so bolts go through the side with the round recess and the lock nuts go through the side with the hexagonal recess. Keep all bolts loose until further step.

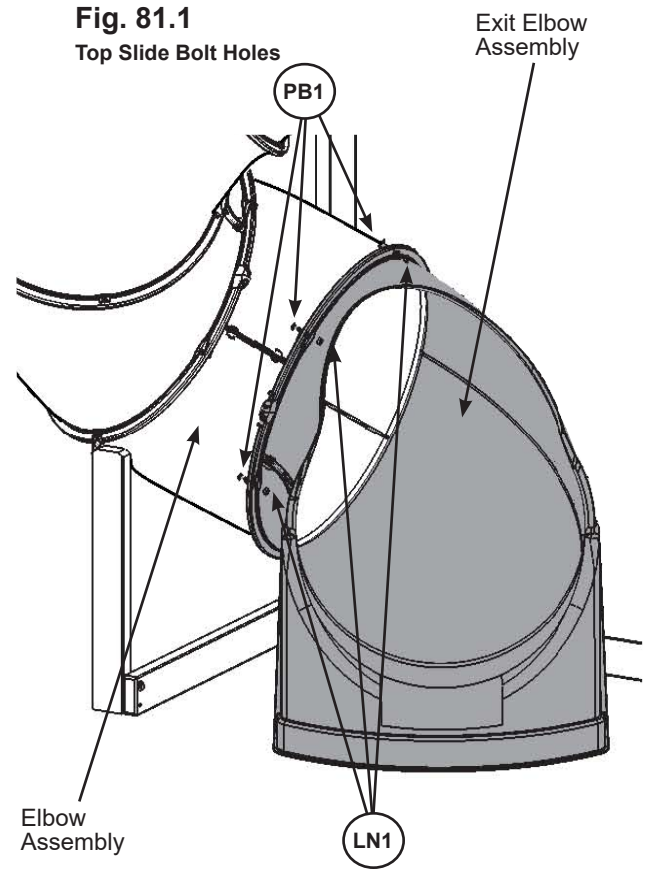
**A:** Fit the Exit End Assembly to the last Elbow Assembly by lining up the arrows on each assembly. Notice the elbow orientation. (fig. 81.1)

**B:** Place 1 TNR2 Slide Clamp Ring to the top of the joined Assemblies, rotate counter clockwise 1 hole location then attach with 3 (PB1) 1/4 x 3/4" Pan Bolts (with LN1 lock nut) as shown in fig. 81.1.

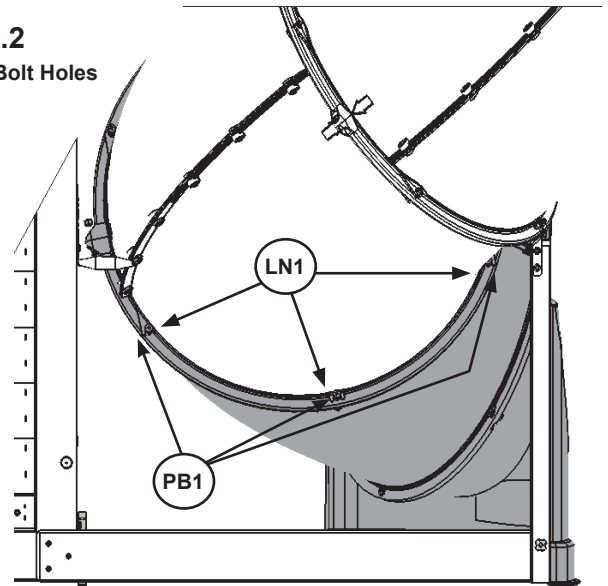
**Use Quadrex Driver as a guide pin for each hole before inserting bolt.**

**C:** Attach 1 TNR2 Slide Clamp Ring to the bottom of the joined Assemblies using 3 (PB1) 1/4 x 3/4" Pan Bolts (with LN1 lock nut) as shown in fig. 81.2.

**D:** Connect the 2 TNR2 Slide Clamp Rings together in 2 spots using 1 (PB1) 1/4 x 3/4" Pan Bolt (with lock nut) per hole. Make sure seams and arrows line up and then tighten all bolts. (fig. 81.3).

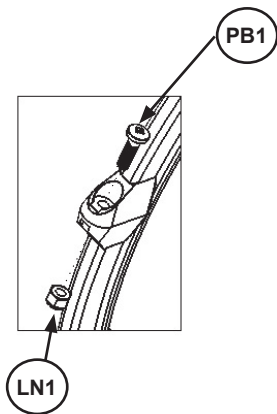


**Fig. 81.2**  
Bottom Slide Bolt Holes



**Fig. 81.3**

After the clamp rings are attached to the elbows, fasten them end to end with two pan bolts and lock nuts



## Hardware

8 x (PB1) 1/4 x 3/4" Pan Bolt (LN1 lock nut)

## Other Parts

2 x TNR2 Slide Clamp Ring

## Step 82: Attach Ground Stake to TNR Upright

**A:** In the spot shown in (Fig. 82.1) drive 1 Rebar Ground Stake 13" (330mm) into the ground against the (8965) TNR Upright. Be careful not to hit the washer while hammering stake into the ground as this could cause the washer to break off.

**B:** Attach the ground stake to (8965) TNR Upright just below the t-nut using 1 (S7) #12 x 2" Pan Screw as shown in (Fig. 82.2).

**C:** After driving stakes into the ground, check for sharp edges caused by the impact of the hammer. Smooth any sharp edges from impact area and touch up with outdoor paint.



**Warning!** To prevent tipping and avoid potential injury, stakes must be driven 13" (330mm) into ground. Digging or driving stakes can be dangerous if you do not check first for underground wiring, cables or gas lines.

Fig. 82.1

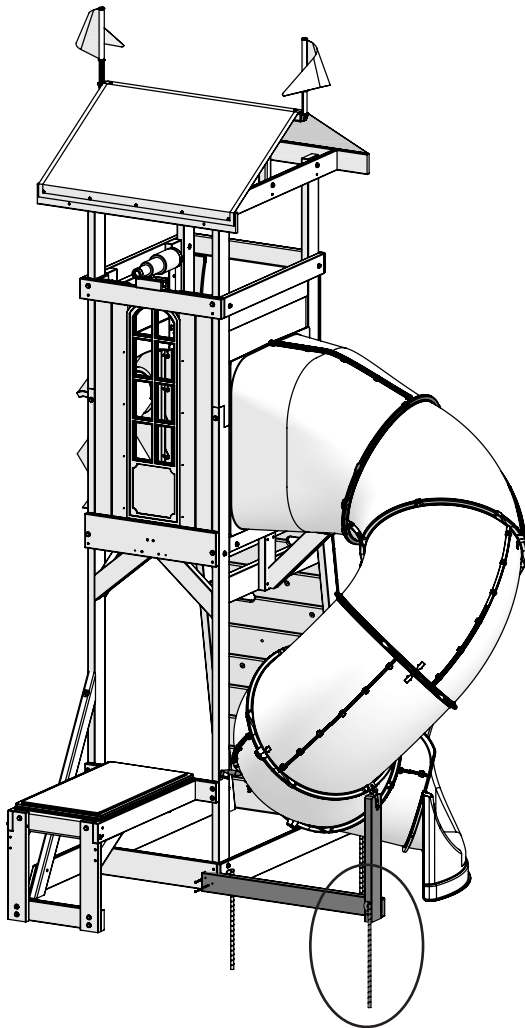
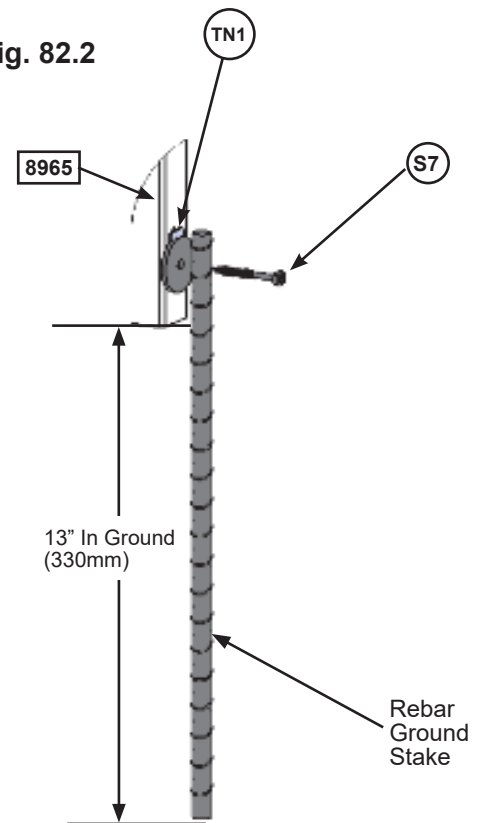


Fig. 82.2



**SEE FRONT COVER FOR  
SAFETY CLEARANCE**

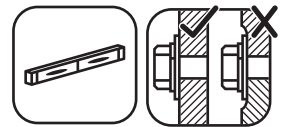
### Hardware

1 x (S7) #12 x 2" Pan Screw

### Other Parts

1 x Rebar Ground Stakes

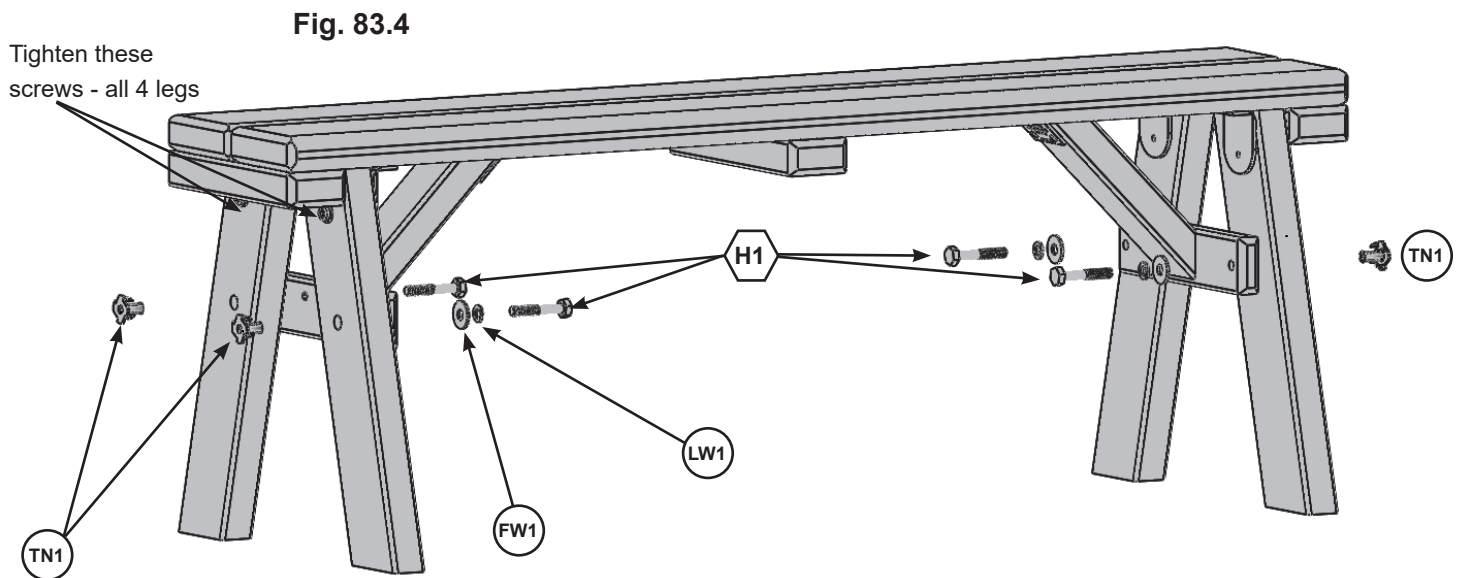
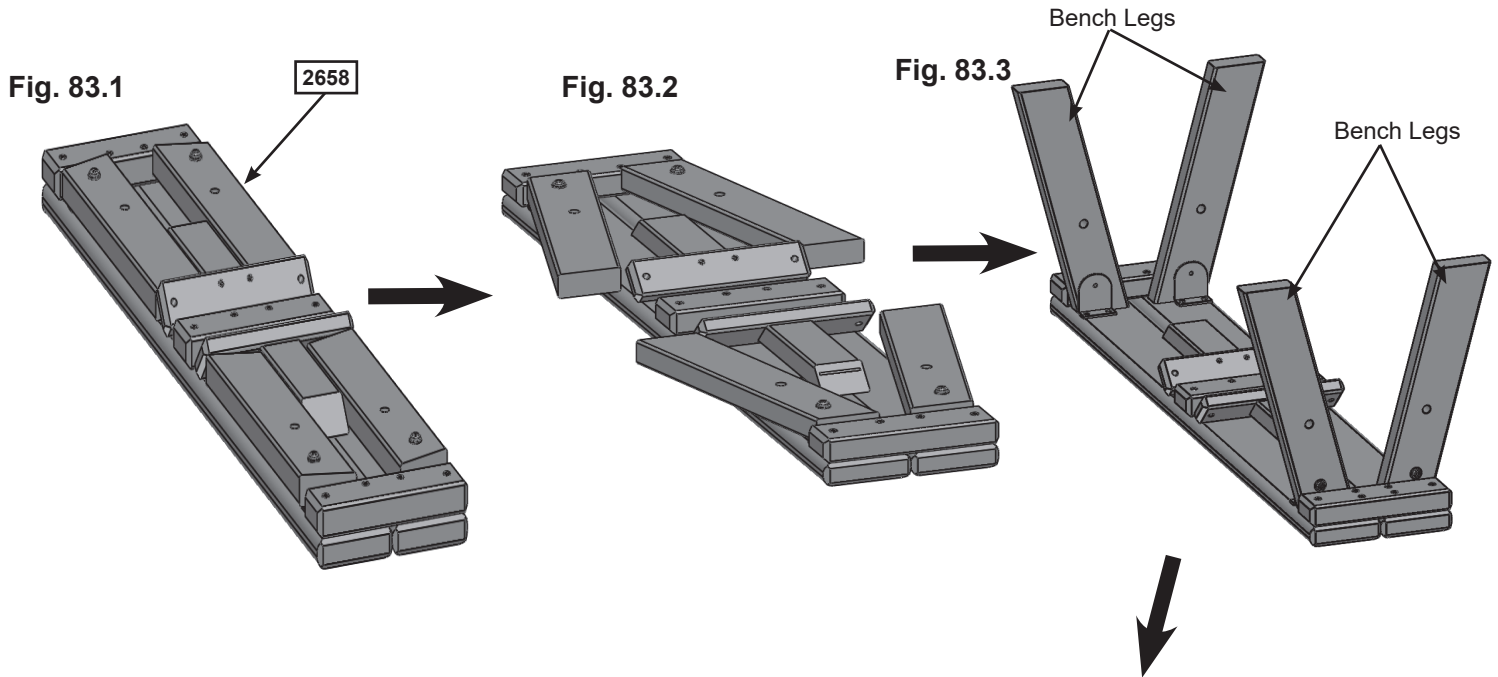
# Step 83: Bench Assembly



**A:** Open the (2658) Folding Bench Assembly. (fig. 83.1, 83.2 and 83.3)

**B:** Make sure assembly is level then secure with 2 (H1) 1/4 x 1-1/2" Hex Bolts (with lock washer, flat washer and t-nut) per side. (fig. 83.4)

**C:** Tighten the top screws in all 4 Bench Legs. (fig. 83.4)



### Wood Parts

1 x **2658** Folding Bench 2-13/32 x 6-3/4 x 34"

### Hardware

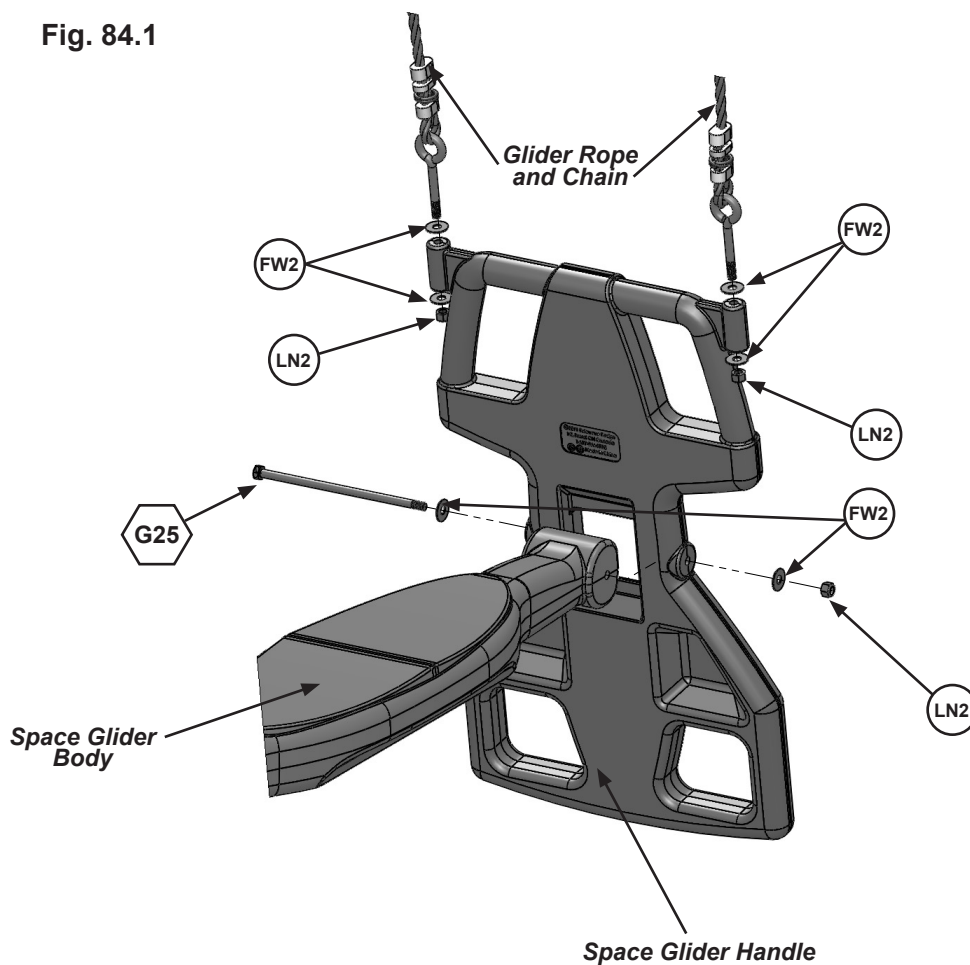
4 x **H1** 1/4 x 1-1/2" Hex Bolt (LW1, FW1, TN1)

# Step 84: Glider Assembly

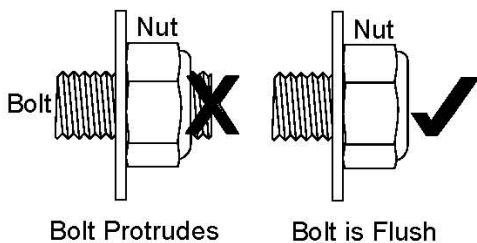
**A:** Attach 1 Space Glider Handle to the Space Glider Body using 1 (G25) 5/16 x 7-1/4" Hex Bolt (with 2 flat washers and 1 lock nut). Repeat for the second Space Glider Handle. (fig. 84.1)

**B:** Install 2 Glider Rope with Chains into each Space Glider Handle using 2 - 5/16" Flat Washers and 1 Lock Nut per rope. (fig. 84.1)


Fig. 84.1



**Warning!** Bolt must not exceed 1/2 thread past the nut



### Hardware

2 x  5/16 x 7-1/4" Hex Bolt  
(FW2 x 2, LN2)

8 x 5/16" FW2

4 x 5/16" LN2

### Other Parts

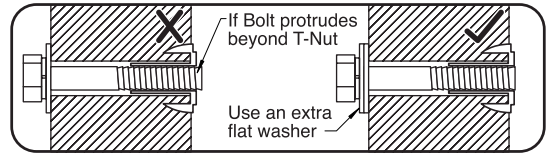
2 x Space Glider Handle

1 x Space Glider Body

1 x Glider Rope and Chain (pkg of 4)

# Step 85: Attach Belt Swings and Glider

**⚠ Warning!** Check entire play centre for bolts protruding beyond t-nuts. Use extra washers to eliminate this condition.



**A:** Attach 2 Belt Swings and assembled Space Glider to the hangers then tighten all Quick Links with an adjustable wrench. (fig. 85.1 and 85.2)

Fig. 85.1

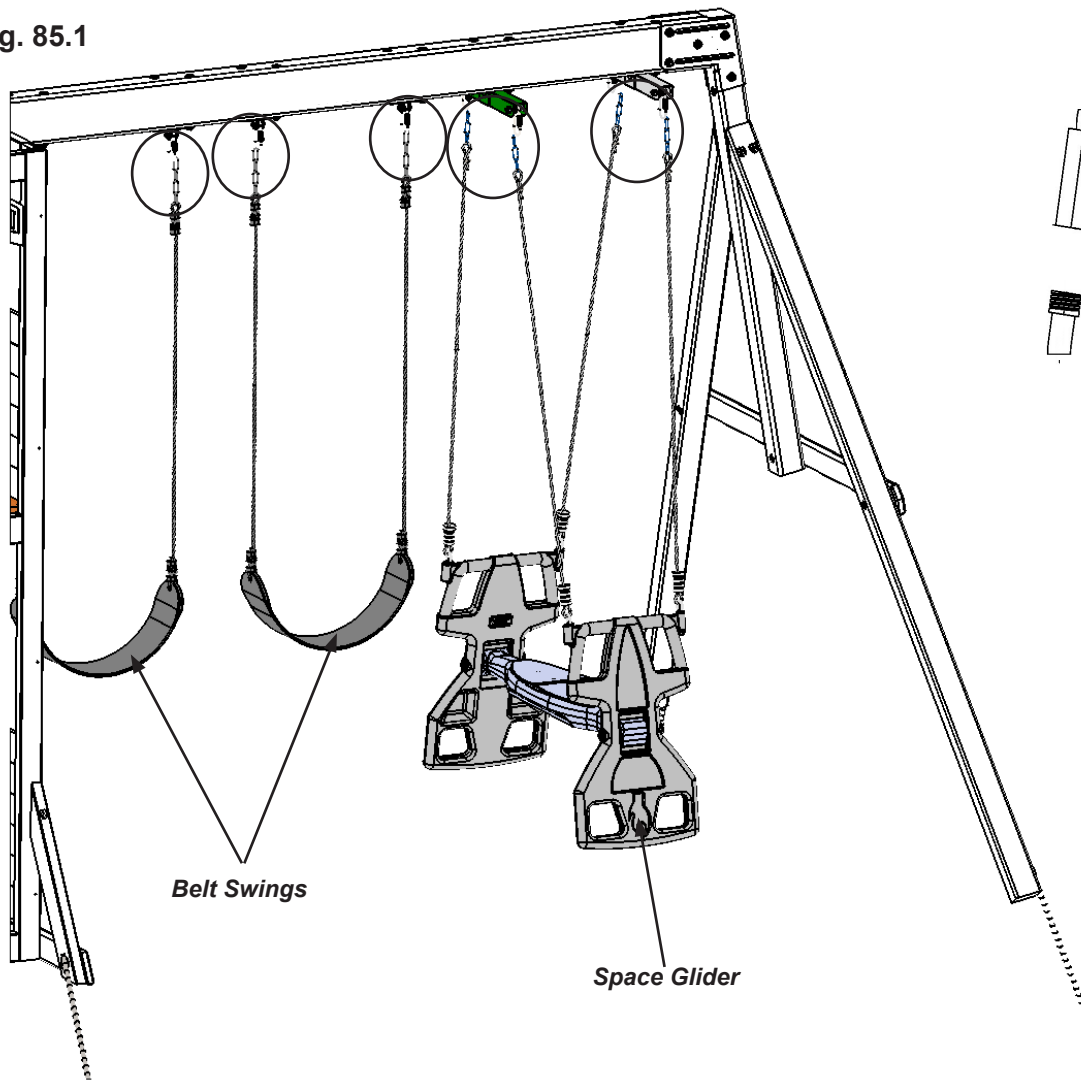
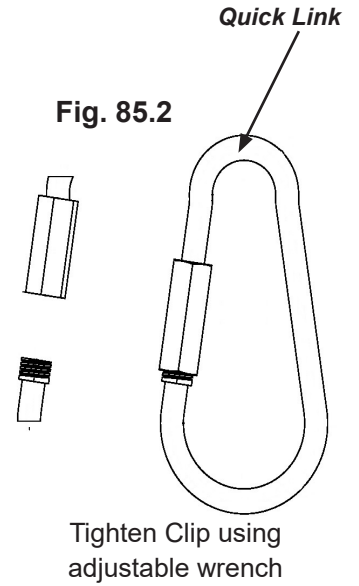


Fig. 85.2



**Other Parts**  
2 x Belt Swings



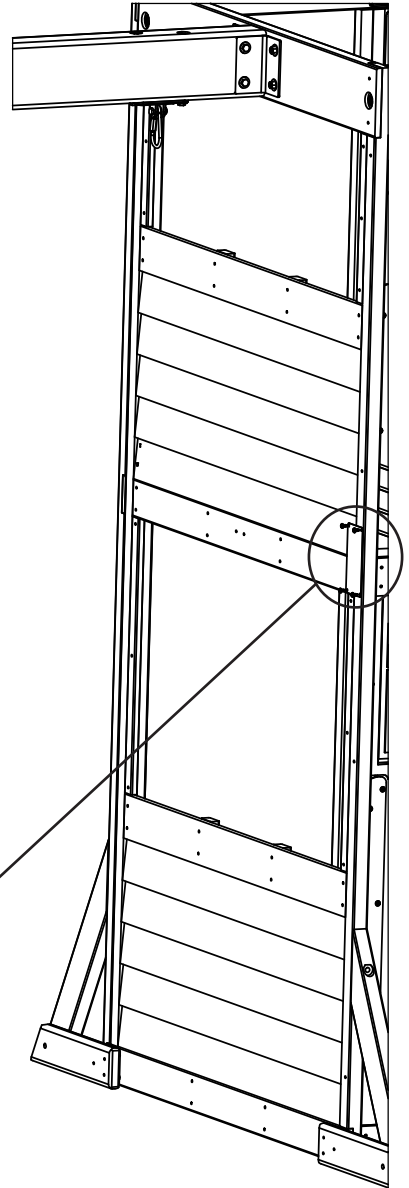
# Final Step: Attach I.D. Plaque

## ATTACH THIS WARNING & I.D. PLAQUE TO THIS LOCATION ON YOUR PLAY EQUIPMENT!

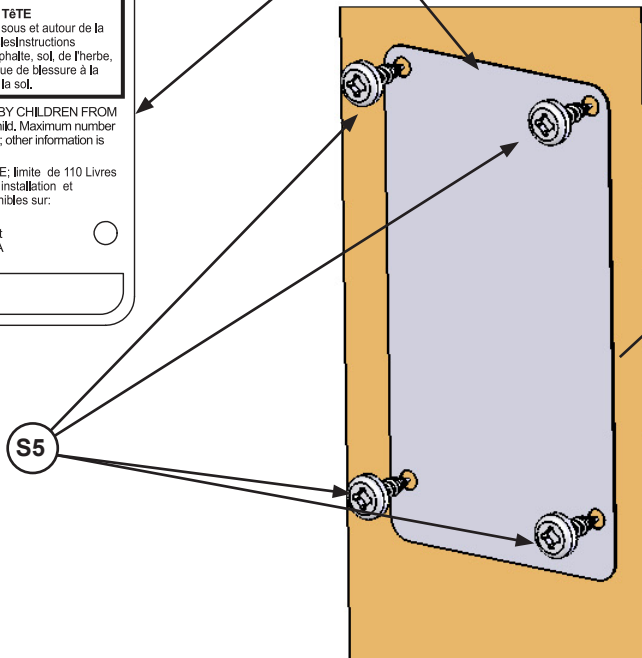
This provides warnings concerning safety and important contact information. A Tracking Number is provided to allow you to get critical information or order replacement parts for this specific model.



A: Attach KidKraft I.D. Plaque to a location on your set that is easily seen and read by a supervising adult using 4 (S5) #8 x 1/2" Pan Screws as shown below.



KidKraft I.D. Plaque



### Hardware

4 x **S5** #8 x 1/2" Pan Screw

### Other Parts

1 x KidKraft I.D. Plaque





# 3 EASY WAYS TO REGISTER YOUR PRODUCT 24/7

- 1) Scan this QR Code with your smart phone to complete your product registration directly from your phone:
- 2) Complete the registration online at: [https://www.kidkraft.com/us\\_en/warranty/](https://www.kidkraft.com/us_en/warranty/)
- 3) Mail this completed form to: KidKraft Inc., 4630 Olin Road, Dallas, Tx 75244 USA  
Make sure to include a copy of your proof of purchase



## KIDKRAFT Consumer Registration Card

First Name \_\_\_\_\_ Initial \_\_\_\_\_ Last Name \_\_\_\_\_

Street \_\_\_\_\_ Apt. No. \_\_\_\_\_

City \_\_\_\_\_ State/Province \_\_\_\_\_ ZIP/Postal Code \_\_\_\_\_

Country \_\_\_\_\_ Telephone Number \_\_\_\_\_

E-Mail Address \_\_\_\_\_

Model Number \_\_\_\_\_ Model Name \_\_\_\_\_

Model Number & Name example  
F2XXXX KidKraft Item Description

Purchased From \_\_\_\_\_ Date Purchase \_\_\_\_\_

MM / DD / YY

Serial Number (on ID Plaque) \_\_\_\_\_



ID Plaque example

Box #: _____ 1 of _____	Box #: _____ 4 of _____	Box # (Ex: BXXXX 1of 6) <b>1 OF 6</b> ITEM # ARTICLE N° N° DE ARTICULO <b>BXXXX</b>
Box #: _____ 2 of _____	Box #: _____ 5 of _____	
Box #: _____ 3 of _____	Box #: _____ 6 of _____	

For common questions or for information on ordering replacement parts:

[https://www.kidkraft.com/us\\_en/warranty/](https://www.kidkraft.com/us_en/warranty/)

Distributed by:  
Costco Wholesale Corporation  
P.O. Box 34535  
Seattle, WA 98124-1535  
USA  
1-800-774-2678  
[www.costco.com](http://www.costco.com)

Costco Wholesale Canada Ltd.\*  
415 W. Hunt Club Road  
Ottawa, Ontario  
K2E 1C5, Canada  
1-800-463-3783  
[www.costco.ca](http://www.costco.ca)

\* faisant affaire au Québec sous  
le nom les Entrepôts Costco

Importado por:  
Importadora Primex S.A. de C.V.  
Blvd. Magnocentro No. 4  
San Fernando La Herradura  
Huixquilucan, Estado de México  
C.P. 52765

RFC: IPR-930907-S70  
(55)-5246-5500  
[www.costco.com.mx](http://www.costco.com.mx)

Costco Wholesale Australia Pty Ltd  
17-21 Parramatta Road  
Lidcombe NSW 2141  
Australia  
[www.costco.com.au](http://www.costco.com.au)

Costco Wholesale UK Ltd /  
Costco Online UK Ltd  
Hartspring Lane  
Watford, Herts  
WD25 8JS  
United Kingdom  
01923 213113  
[www.costco.co.uk](http://www.costco.co.uk)

Costco Wholesale Spain S.L.U.  
Polígono Empresarial Los Gavilanes  
C/ Agustín de Betancourt, 17  
28906 Getafe (Madrid) España  
NIF: B86509460  
900 111 155  
[www.costco.es](http://www.costco.es)

Costco Wholesale Iceland ehf.  
Kaupún 3-7, 210 Gardabaer  
Iceland  
[www.costco.is](http://www.costco.is)

Costco France  
1 avenue de Bréhat  
91140 Villebon-sur-Yvette  
France  
01 80 45 01 10  
[www.costco.fr](http://www.costco.fr)

Costco Wholesale Japan Ltd.  
2 Kakuchi, 2 Gaiku, Kaneda-Nishi  
361 Urakura, Kisarazu shi  
Chiba, 292-0007 Japan  
0570-200-800  
[www.costco.co.jp](http://www.costco.co.jp)

Costco Wholesale Korea, Ltd.  
40, Iljik-ro  
Gwangmyeong-si  
Gyeonggi-do, 14347, Korea  
1899-9900  
[www.costco.co.kr](http://www.costco.co.kr)

Costco Wholesale New Zealand Limited  
2 Gunton Drive  
Westgate  
Auckland 0814  
New Zealand  
[www.costco.co.nz](http://www.costco.co.nz)

Costco (China) Investment Co., Ltd.  
Room 1003, Block 2, 2388 Xiupu Road,  
Pudong New Area, Shanghai  
China 201315  
+86-21-6257-7065

Costco Wholesale Sweden AB  
Box 614  
114 11 Stockholm  
Sweden  
[www.costco.se](http://www.costco.se)