



Intuity Home Automation System

Installation Manual

1308240 REV. H



Compliance

FCC Notice – FCC ID:

These devices comply with part 15 of the FCC Rules. Operation is subject to the following two conditions: (1) These devices may not cause harmful interference, and (2) these devices must accept any interference received, including interference that may cause undesired operation.

Canadian Department of Communications – IC:

These devices comply with Industry Canada license-exempt RSS standard(s). Operation is subject to the following two conditions: (1) these devices may not cause interference, and (2) these devices must accept any interference, including interference that may cause undesired operation of the devices.

These Class B digital apparatus comply with Canadian ICES-003.

TABLE OF CONTENTS

Compliance	ii
1.0 Introduction	1
1.1 Intuity System Overview	1
1.2 Prerequisites	2
1.3 Best Practices	2
2.0 Physical Installation	4
2.1 Network Subsystem	4
2.1.1 Routers	4
2.1.2 Wireless Access Points.....	4
2.1.3 Switches	4
2.2 Intuity System	5
2.2.1 Controller	5
2.2.2 Command Center	5
2.2.3 Bridges	6
2.3 Digital Audio Subsystem	7
2.4 Intercom Subsystem	8
2.5 Security Subsystem	9
2.6 IP Camera Subsystem	12
3.0 App Downloads	13
4.0 Intuity Account Creation	14
4.1 Create Intuity Account.....	14
4.2 Register the System (HA7000 Intuity Controller)	15
5.0 Add/Configure Rooms/Users	16
5.1 Add/Configure Rooms.....	16
5.2 Add/Configure Users.....	17
6.0 Adding Wireless Devices	18
6.1 Adding a WiFi to RFLC Bridge	18
6.1.1 Access Website and Provision Bridge	18
6.1.2 Add a WiFi to RFLC Bridge to Intuity	21
6.1.3 Add RFLC Devices	23
6.1.4 Scene Controllers	25
6.2 Adding a WiFi to Z-Wave Bridge	26
6.2.1 Access Website and Provision Bridge	26
6.2.2 Add WiFi to Z-Wave Bridge to Intuity System	28
6.2.3 Removing Z-Wave Device ID.....	30
6.2.4 Adding a Z-Wave Device to Intuity.....	32
6.3 Adding Wireless Thermostats	33
6.3.1 Add a WiFi Thermostat to the Intuity System.....	33
6.3.2 Add a Z-Wave Thermostat or Garage Door Opener to the Intuity System....	41
6.4 Adding QMotion Shades	42
6.4.1 Prior to Adding Shades.....	42
6.4.2 Adding Shades	42
7.0 Adding Wired Devices	44
7.1 Adding a Security Subsystem	44

7.2 Adding IP Cameras	49
7.2.1 Adding remote viewing to IP Cameras	49
7.3 Adding a Digital Audio Subsystem	50
7.4 Adding Intercom System Door Units	51
8.0 Creating Activities	52
8.1 Creating a Doorbell Notification Activity	52
Appendix A: FAQ	56
Appendix B: Advanced System Commissioning.....	59

1.0 Introduction

This Intuity System Installation Manual (P/N [1308240](#)) provides the information necessary to install a complete Legrand Intuity Home Automation System. There are also individual Installation Sheets that ship with each component of the system to cover that component's physical installation, and a User Guide (P/N [1308241](#)) that provides further information on the operation of the system once installed.

1.1 Intuity System Overview

The Legrand Intuity Home Automation System provides a convenient means for integrating a home's subsystems, such as Digital Audio, Security, Video Door Entry, Lighting Control, Cameras, etc. Monitoring and Control is provided from a built-in Command Center in the home, or remotely from a customer's mobile device or tablet, each with the same consistent, intuitive app.

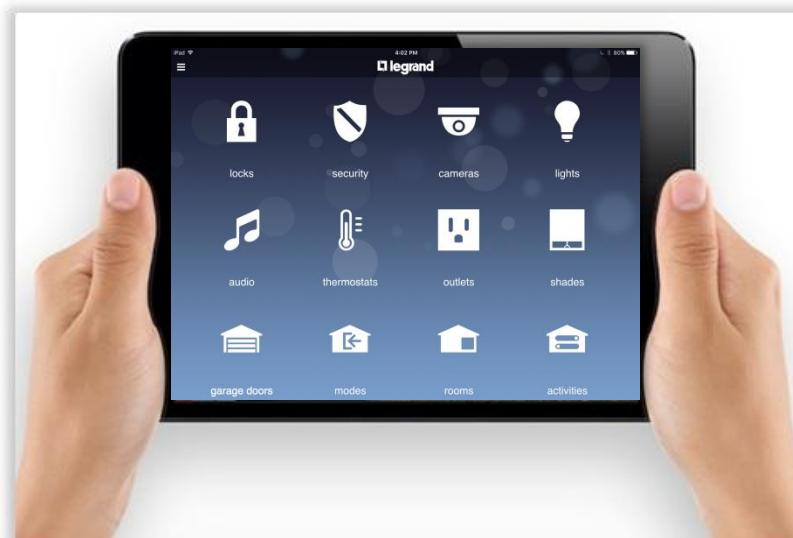

While it is possible that an Intuity System would be installed at the same time as all the other subsystems as part of new-construction, it is meant to be installed after one or more pre-existing subsystems are installed, such as the Legrand Digital Audio System.

1.2 Prerequisites

In order for the Legrand Intuity Home Automation System to function, it requires Internet service and a Wireless Access Point connected to the same LAN as the [HA7000](#) Intuity Controller.

NOTE: Please refer to the Builder IT department on this requirement to ensure the system can be commissioned using the existing network in a Model Home/Design Center environment for demonstration purposes.

It is also required to have all associated Legrand subsystems such as the Digital Audio System, RFLC Lighting System, IP Cameras and WiFi to RFLC and Z-Wave Bridges installed and configured prior to completing the installation of the Intuity System.

1.3 Best Practices

Before beginning the installation of Intuity, the integrator must make sure all subsystems are installed to Legrand standards. This includes: the RFLC Lighting System, the Digital Audio System, IP Cameras, Intercom (Video Door Entry) and Legrand approved security systems, as well as third party products. To see a list of compatible third party peripherals that can be integrated into the Intuity System, please visit the following website: www.legrand.us/home-automation/intuity-third-party-systems

- Follow TIA/EIA-568/569/570 for Cat 5 / Cat 6 wiring.
- T568A standard is recommended for wire termination.
- ANSI/CEA/CEDIA-2030-A and NEC 800.113-A should be observed
- Follow industry recognized standards of
 - 12" separation between high and low voltage wiring in parallel, only crossing at 90 degrees
 - In Wall rated LV cable (Cat5/5e/6/6a, speaker wire, etc...) should be used
- Installers must be trained and well versed with Legrand subsystems, and the Intuity system, before beginning an installation. Legrand provides regularly scheduled webinars, recorded webinar content and online training. Please visit Legrand University for more details: <http://go.bluevolt.com/Legrand/Catalog/On-Q-Training/11773/>
- It is recommended to personalize subsystems (Audio, Security, etc) with Room/Zones names before commissioning an Intuity system. This will make it much easier to identify individual items later, as those names will be automatically transferred during commissioning of the Intuity system.
- It is recommended that the Installer record all IP Camera Port numbers (if Cameras have been port forwarded through a Router for the purpose of Remote viewing)
- High Speed Internet Connection with a minimum speed of 5 Mbps is required. Cable, DSL or Fiber recommended.

- Best practice for commissioning/provisioning the Intuity system is to use a browser (Chrome/Safari) via a Notebook, Tablet, or Laptop Computer. To Log in, or setup an account, please go to: <https://intuity.legrand.us>
- Creating a new Intuity account requires the Homeowners email address and will require the Homeowner to click an activation link in a confirmation email that will be sent to that address. It is recommended that the Homeowner be present and available to access their email at the time of account creation.
- The installer should use a temporary (generic) password for the Homeowner to log into the system (i.e. PASSWORD). This can be change to a preferred password later by the Homeowner, by logging into <https://intuity.legrand.us> with their temporary password. See Appendix B of this document (How do I change my Password)
- The Homes WiFi network (SSID) must be broadcasting (visible) in order to provision WiFi to RFLC and WiFi to Z-Wave bridges to the network
- It is recommended that the installer download and install the Legrand Intuity App (via the Apple App Store or the Google Play Store) on the Homeowners iOS/Android device(s) for them, (for example an iPad Mini 1, 2, or 3 to be used in the HA7110 Command Center). (See Section 3.0 of this manual). See our [Qualified Third Party Peripherals](#) list for more information on compatibility.
- It is recommended the Installer provide the Home Owner with a general demonstration of the system and its capabilities after commissioning is complete.

2.0 Physical Installation

2.1 Network Subsystem

The Network Subsystem consists of an ISP Modem/Router, Switches (Legrand [DA1458](#) and [PW1458](#) recommended), and possibly additional Wireless Access Points (WAPs) (Legrand [DA1104](#) recommended). We realize it is not always possible to utilize Legrand network components, but it is highly recommended, as these products are tested to work with our system and very familiar to our Technical Support staff in the event that support is required in the future.

2.1.1 Routers

Legrand recommends using the homeowner's ISP (Internet Service Provider) WiFi Modem/Router for the Legrand Intuity and Digital Audio Systems. If the ISP supplied Network Appliance is a modem only (no router), a list of compatible routers can be found at <http://www.legrand.us/onq/router-compatibility.aspx> .

2.1.2 Wireless Access Points

If additional WiFi is required, Legrand recommends the use of the Legrand [DA1104](#) AC WAP. The owner's manual for the [DA1104](#) AC (P/N [1308237](#)) is available on the <http://www.legrand.us> website. In addition, a list of compatible Wireless Access Points can be found at <http://www.legrand.us/onq/router-compatibility.aspx> .

2.1.3 Switches

Legrand 8-Port Gigabit switch products ([DA1008](#) and [DA1458](#)) expand the number of switch ports available on the router. The [DA1458](#) provides Power over Ethernet capabilities on 4 of its 8 ports to power devices such as the Legrand IP Cameras. The owner's manual for the [DA1458](#) is P/N [1308145](#) and it is available on the <http://www.legrand.us> website.

NOTE: The [DA1008](#) requires the purchase of a separate power supply which is P/N [PW7760](#). The [DA1458](#) also requires the purchase of a separate power supply which is P/N [PW1458](#).

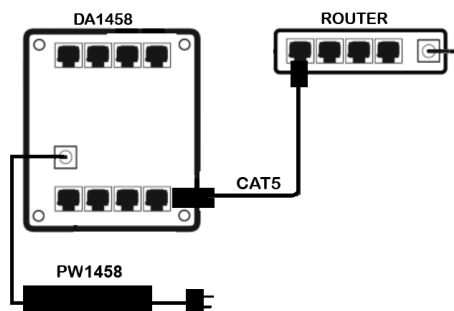

2.2 Intuity System

The Intuity System consists of the [HA7000](#) Intuity Controller, the [HA7110](#) Command Center, the [HA7020](#) WiFi to RFLC Bridge and the [HA7040](#) WiFi to Z-Wave Bridge. These units can be powered using the [PW1013](#) Power Distribution Module and the [PW7760](#) Power Supply.

2.2.1 Controller

The Legrand [HA7000](#) Intuity Controller is the heart of the Intuity Home Automation System. It is installed in the enclosure, and typically powered via the [PW1013](#) and the [PW7760](#). The installation sheet for the [HA7000](#) Intuity Controller (P/N [1507205](#)) comes with the product. The [HA7000](#) Intuity Controller connects with a Cat 5 cable to the security system via the RS232 jack and to the Intercom system via any one of the Intercom 1-8 jacks. A Cat 5 jumper is used to connect to an Internet router/switch port via the LAN jack as shown below.

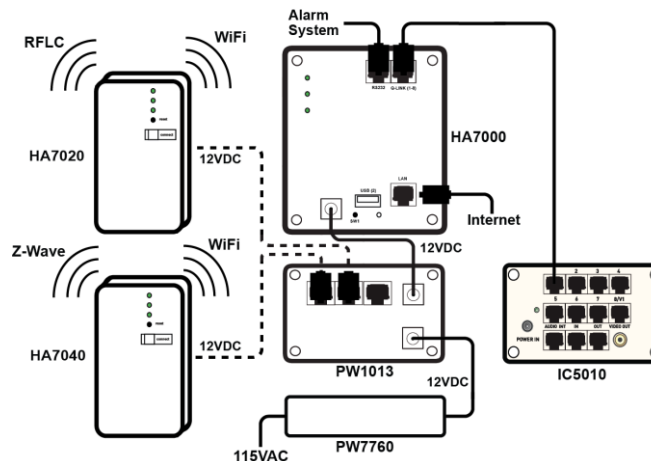

2.2.2 Command Center

The Legrand [HA7110](#) Command Center is the primary fixed user-interface for the Intuity Home Automation System. It is a wall-mounted User Interface, located in a convenient area, which houses the customer supplied iPad Mini. **NOTE: Only the iPad Mini 1, 2 and 3 are compatible with the Legrand HA7110 Command Center. The iPad Mini 4 and other Android tablets are not able to be mounted into this device.**

The instruction sheet supplied with the [HA7110](#) (P/N [1507235](#)) outlines physical installation instructions. The [HA7110](#) Command Center is designed to fit easily into a Pass & Seymour S352W triple gang old work electrical device box, S354RAC triple gang new work electrical device box and the AC1010-03 triple gang LV retrofit bracket. It also requires two Cat 5 cables, plus a 16/2 speaker wire run from the enclosure. The supplied custom USB/audio cable that will be attached to the iPad Mini before it is installed in the Command Center to power the iPad

Mini and provide an audio output. Note that the iPad Mini should not be installed into the Command Center until all other Intuity subsystems have been installed and configured.

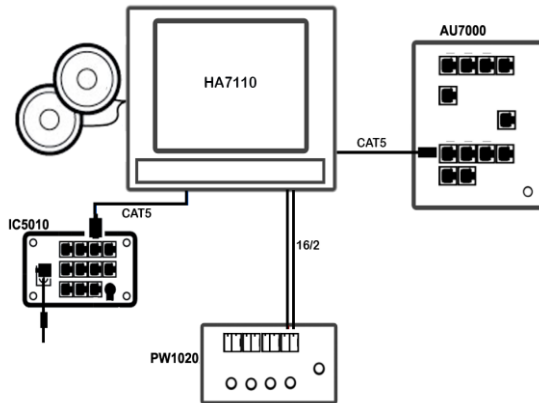

2.2.3 Bridges

The Legrand [HA7020](#) WiFi to RFLC Bridge and [HA7040](#) WiFi to Z-Wave Bridge are typically wall-mounted to single-gang boxes central to the home's WiFi network and near the devices they are wirelessly controlling (typically lighting devices for the [HA7020](#) and thermostats, garage door opener or wireless door locks for the [HA7040](#)). The installation sheets are shipped with the products (P/N [1507221](#)) for the [HA7020](#) and (P/N [1507222](#)) for the [HA7040](#).

NOTE: Bridges require 2.4GHz WiFi (B,G,N or AC) network.

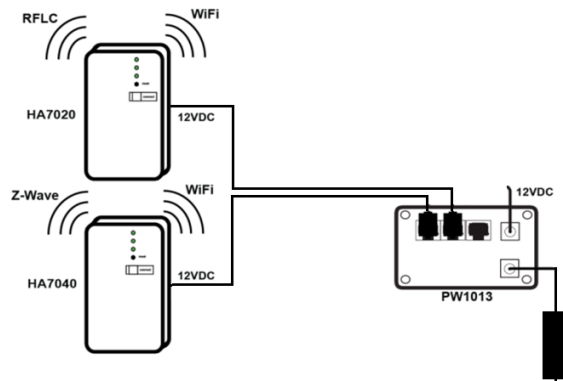

2.3 Digital Audio Subsystem

The Legrand Digital Audio Subsystem consists of several components, including the [AU7000](#) Digital Audio Distribution Module, [AU7004](#) Audio Expansion Module, the [AU7001](#) Digital Audio Input Module, [AU7010](#) and High Performance [AU7050](#) Amplified Keypads, [AU7007](#) Global and [AU7008](#) Local Source Inputs, the [PW1020](#) Digital Audio Power Distribution Module and associated PW1060 Power Supplies and the [PW7760](#) Power Supply for the [AU7000](#). The [AU7000](#), [AU7004](#) and [AU7001](#) components are all installed in the enclosure, while the keypads and source inputs are installed in individual room locations. The installation sheets are included with all these components:

- [AU7000](#) – (P/N [1507204](#)) – Digital Audio Distribution Module
- [AU7001](#) – (P/N [1507203](#)) – Digital Audio Input Module
- [AU7004](#) – (P/N [1507206](#)) – Digital Audio Expansion Module
- [AU7007](#) – (P/N [1507220](#)) – Digital Audio Global Source Input
- [AU7008](#) – (P/N [1507219](#)) – Digital Audio Local Source Input
- [AU7010](#) – (P/N [1507218](#)) – Digital Audio Amplified Keypad
- [AU7050](#) – (P/N [1507217](#)) – Digital Audio High-Performance Amplified Keypad
- [PW1020](#) – (P/N [1507202](#)) – Digital Audio Power Distribution Module

NOTE: All of these Digital Audio components should be installed and configured before installing the Intuity System. The [AU7000](#) in particular should be updated via the Digital Audio App to the latest version of firmware for best functionality with the Intuity System. To check for the latest firmware update from the app:

1. Select the settings cogwheel at the top right of the app
2. Select “General”
3. Select “Software Update”
4. Select “Distribution Module”

The app will display whether you have the latest software version. If an update is required, a prompt will appear to perform the update automatically.

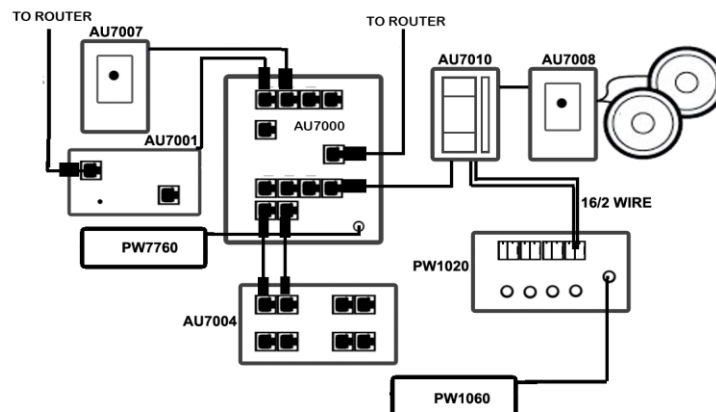

2.4 Intercom Subsystem

The Legrand Intercom Subsystem consists of several components, including the [IC5010](#) Selective Call 8-Location Distribution Module, [IC5000](#) Room Unit, [IC5002](#) Door Unit, [IC5003](#) Video Door Unit, [IC5004](#) Patio Unit and IC7000 Broadcast Room Unit. The [IC5010](#) is installed in the enclosure and is powered by the [PW1030](#) power supply. While the Room, Door and Patio Units are installed in individual room locations. The installation sheets included with all these components are as follows:

- [IC5010](#) – (P/N [1507214](#)) – Selective Call Intercom Module
- [IC5000](#) – (P/N [IS-0386](#)) – Selective Call Intercom Room Unit
- [IC5002](#) – (P/N [IS-0387](#)) – Selective Call Intercom Door Unit
- [IC5003](#) – (P/N [IS-0426](#)) – Selective Call Intercom Video Door Unit
- [IC5004](#) – (P/N [IS-0388](#)) – Selective Call Intercom Patio Unit
- [IC7000](#) – (P/N [1507223](#)) – radiant Broadcast Intercom Room Station
- IC7001 – (P/N 1308003) – radiant Selective Call Intercom Room Station

NOTE: All of these Intercom components should be installed and configured before installing the Intuity System.

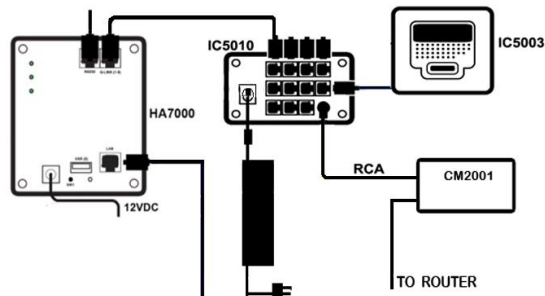

2.5 Security Subsystem

The Legrand Intuity Home Automation System is designed to integrate with multiple third party security systems, including the Interlogix Concord 4 and NetworX systems, Honeywell Vista 15p/20p/21ip systems, DSC Power Series Neo and others (Refer to the third party systems website at www.legrand.us/home-automation/intuity-third-party-systems for more information).

These third party systems utilize an RS232 adapter to interface to third party equipment. This adapter may need to be added to the actual security system if it was not previously installed.

All of the components of these third party security systems should be installed and configured to the specifications set by the manufacture and the security installer before installing the Intuity System. Once the Intuity System is installed, make the following connection to the security subsystem:

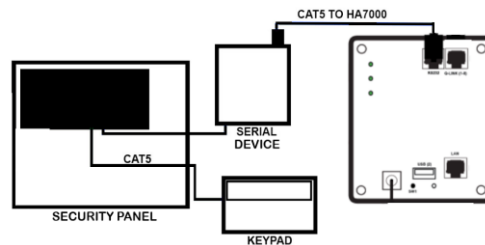

For the Honeywell Vista 15p/20p/21iP, the 4232CBM adapter is required. White/Blue connects to GRD, White/Orange connects to RX (Receive) and Orange connects to TX (Transmit). The CAT5 in this example follows the T568A standard.



For the Interlogix Concord 4 System, the SB2000 Automation Module (Part# 60-783-02) is required. A DB9 to RJ45 plug-in adapter is supplied with the [HA7000](#) Intuity Controller that will allow a direct connection from the Intuity Controller into the SB2000.

For the Interlogix NetworkX Security System, an NX-584 Automation Module is required.

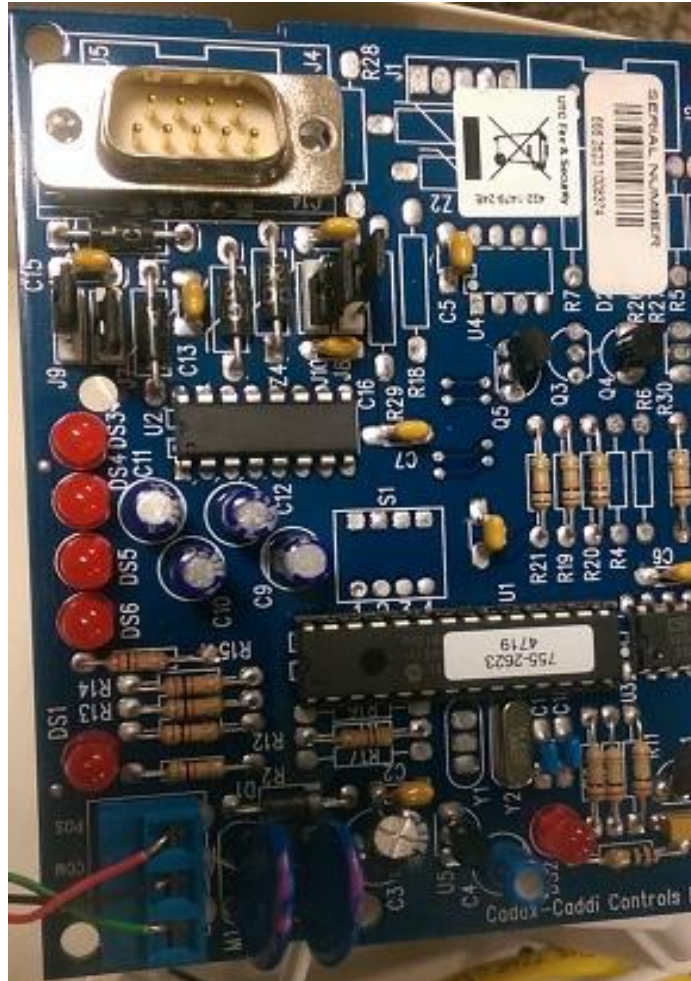

Please refer to the manual that is supplied with the NX-584 Automation Module for further instructions on setup.

The following must be configured on the NX-584:

The Jumper positions need to be set opposite of the default on the NX-584 Automation Module:

- J7 = B
- J8 = A
- J9 = A
- J10 = B

To connect to the Intuity Controller, the RS-232 port (J6) of the NX-584 connects to the supplied [HA7000](#) DB9 Adapter and then to the RS232 port on the HA7000. The pins are as follows:

- J6 DB9 -> Cat5
- Pin 5 -> Pin 5
- Pin 3 -> Pin 3
- Pin 2 -> Pin 6

NOTE: The supplied DB9 to RJ45 adapter will require a serial female to female gender adapter for proper connectivity to the NX-584. Depending on the type of gender adapter being used, the connection to the NX-584 may be loose. An alternate method of connection to the NX-584 would be a custom RJ-45 to Female DB9 adapter created using the pins listed above.

For the DSC Power Series Neo, the TL280 (R) Alarm Panel Communicator is required. ***The R revision is important as it contains the correct serial interface that allows for communication to the Intuity Home Automation System. It is recommended that v5.0 of the communicator is installed. The TL280 (RE) is also compatible but requires additional changes in the setup.***

A CAT5 cable MUST be terminated using the 568A standard. The White/Blue will connect to the GND terminal on the TL280(R). The White/Orange will connect to the RX+ terminal and the Orange will connect to the TX+ terminal.

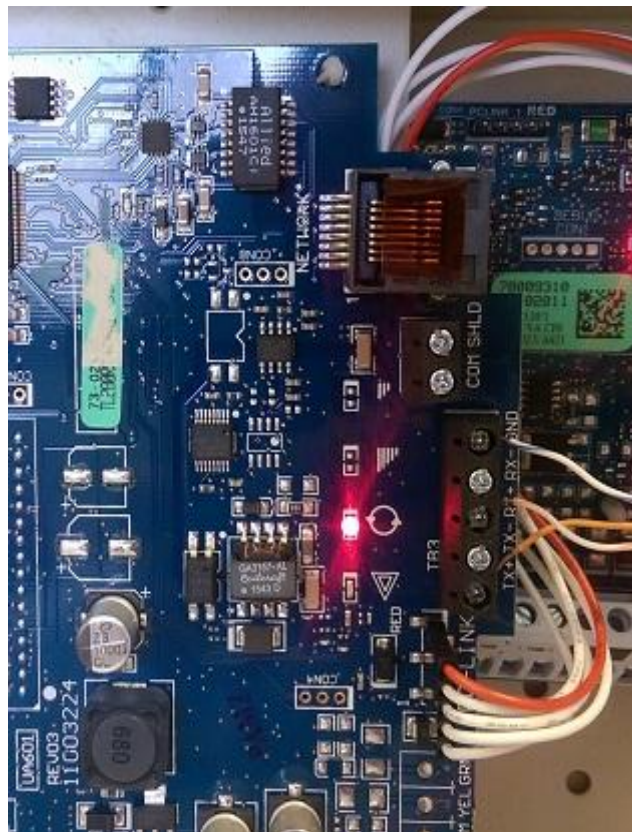

2.6 IP Camera Subsystem

The Legrand Intuity System is designed to support either of the Legrand IP Cameras ([CM7000](#)/[CM7100](#)) and the Legrand [CM2001](#) IP Server. The installation sheets included with these components are as follows: [CM7000](#) – (P/N [1507215](#)), [CM7100](#) – (P/N [1507216](#)) and [CM2001](#) – (P/N [IS-0593](#)).

Important Notes:

- A. All of the IP Camera Subsystem components should be installed and configured before installing the Intuity System.
- B. Once the Intuity System is commissioned, Cameras should automatically appear active on the user interface. There is NO need to use the Device Assistant for device discovery. The Device Assistant can be used to configure the camera names, port settings and assign the cameras to a room.
- C. For external Camera viewing, cameras will need to be port forwarded through the homes router. Refer to section 7.2 for more detail.
- D. A [CM2001](#) Video Door Enabling Kit, and a composite video cable, is for connection to the video output on the IC5010 Intercom Module, in order for the Video Door Camera to be displayed on the Intuity System.

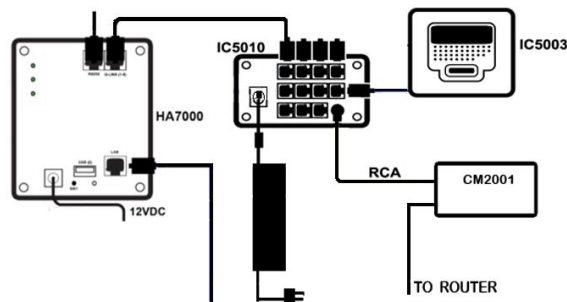

3.0 App Downloads

There are two iOS/Android Apps available from the iTunes Store or the Google Play Store associated with the Intuity System. The apps are as follows:

The Legrand Digital Audio App (this one may have been previously downloaded when the Legrand Digital Audio System was installed and configured).



The Legrand Intuity App



Download the Apps onto the homeowner's mobile device/s and tablet/s. Supported devices include iPad Air (and Air 2), iPad Mini, iPod Touch and iPhones running iOS version 8.3 or later as well as Android devices running Lollipop version 5.1.1 or later.

NOTE: Sign in to the Intuity system from outside the home via the App, or via a Chrome or Safari web browser at <https://intuity.legrand.us>.

4.0 Intuity Account Creation

4.1 Create Intuity Account

After physically installing and configuring Intuity along with all other subsystems, go to <https://intuity.legrand.us> with a Notebook, Tablet, or Laptop Chrome/Safari browser.

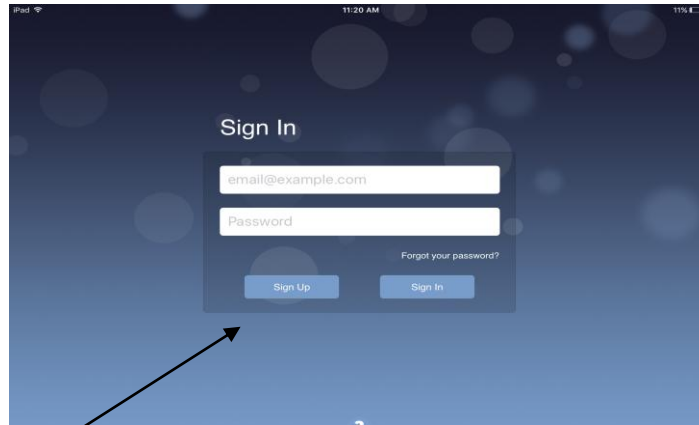

Select "Sign Up" and type in the information requested.

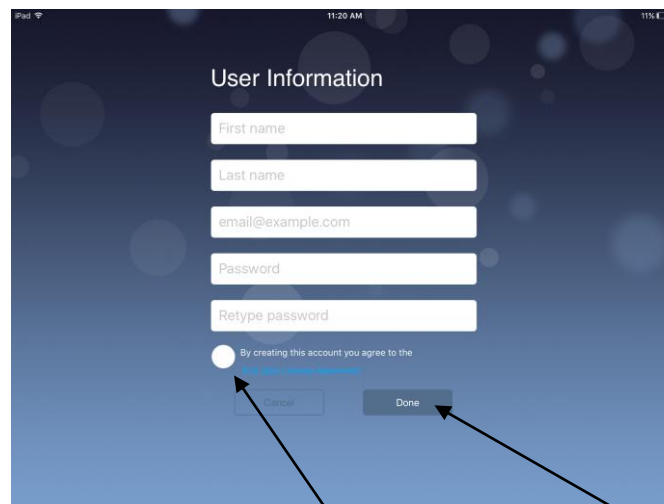

Once complete, agree to the "End User License Agreement" and press "Done".

Legrand will now send a confirmation email to the email address entered with an embedded activation link. Have the customer tap on the link and their account will be activated.

NOTE: System Commissioning cannot continue until the homeowner has clicked the activation link in the confirmation email. If the email does not appear, check to make sure that the confirmation email has not been moved to the customers "Spam" folder.

4.2 Register the System (HA7000 Intuity Controller)

After successfully creating the Intuity account, “sign in” to the account via a web browser.

Follow the on-screen instructions, filling in the required information.

1. The six digit registration number is found on the front of the HA7000.
2. Name the controller and enter the zip code. Then tap “Done”.
3. A screen will appear indicating that “The controller was successfully registered”.
4. Tap “Get Started” to begin configuring the system.

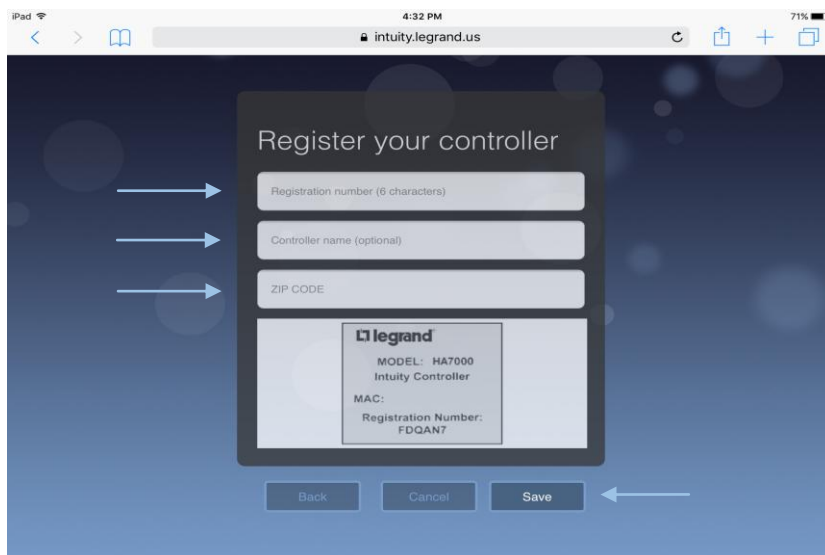
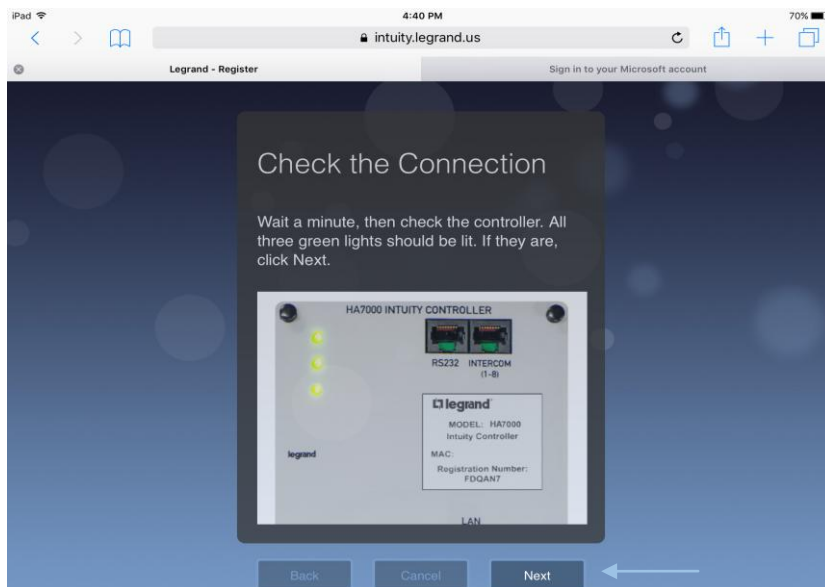

5.0 Add/Configure Rooms/Users

5.1 Add/Configure Rooms

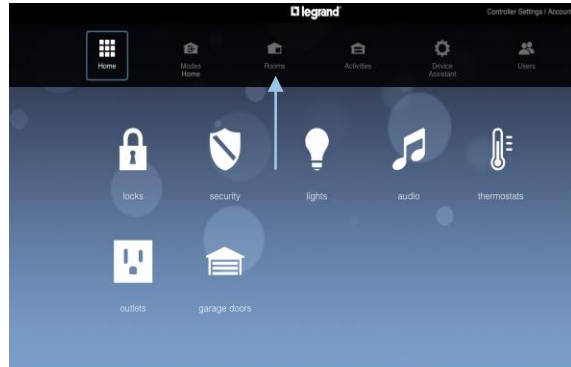

After signing in to the Intuity Systems browser interface, tap the “Rooms” icon from the home screen.

Then, press the “+” icon in the upper right corner to add a new room.

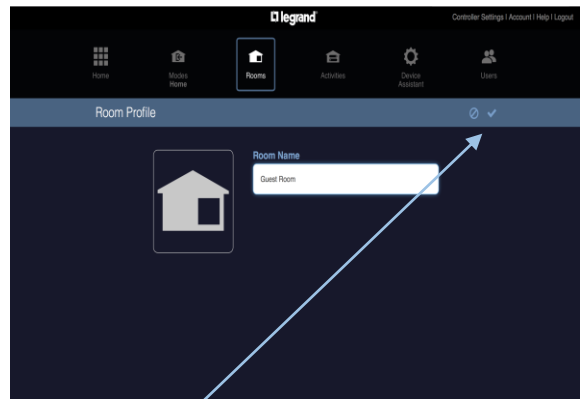

Type in the desired room name and press the check mark in the upper right corner to save. Add as many rooms as needed. It is recommended to have all rooms named before adding devices. Devices can then be assigned to a room as they are added.

5.2 Add/Configure Users

NOTE: Users are ONLY added to the system for email notification of system activities.

From the Home screen of the browser-based controller, click the “Users” icon.

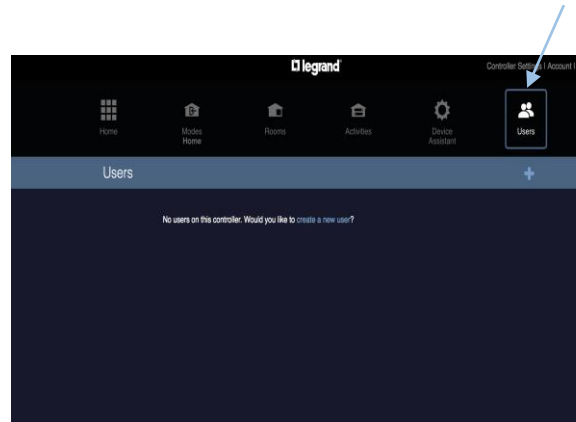

Then, click the “+” icon in the upper right corner to add a user.

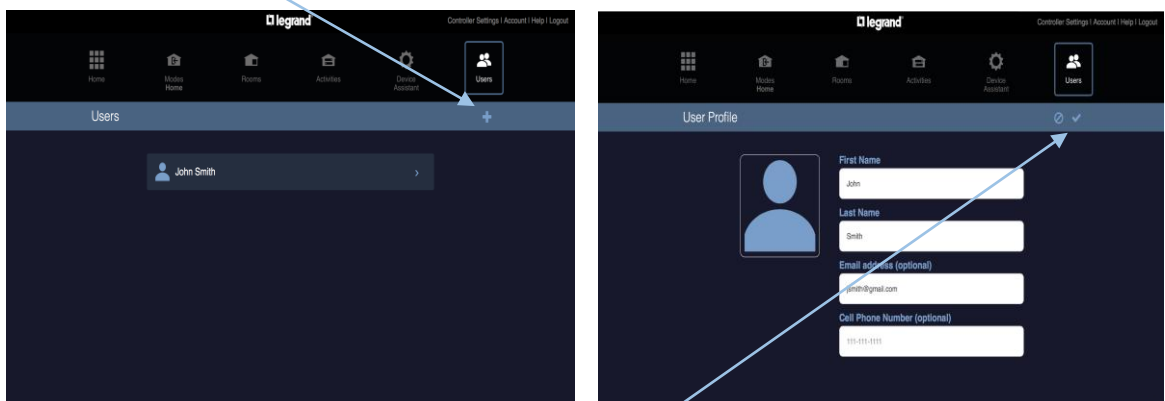

Type in the user’s credentials and click the check mark to save. The result page below will display the new user.

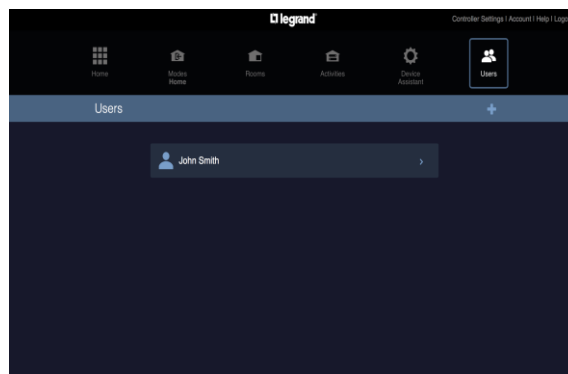

6.0 Adding Wireless Devices

6.1 Adding a WiFi to RFLC Bridge

The WiFi to RFLC Bridge will act as a WiFi Hotspot when first connected to power. Its SSID is Legrand Bridge XXXX (*XXXX are the last 4 digits of its MAC address which can be found on the label on the back of the unit*). The top LED is the power LED and will be on solid (white) when power is applied. The middle LED is WiFi, and it should be blinking slowly at this point. The bottom LED is the Hub LED and will be off at this point.



6.1.1 Access Website and Provision Bridge

Step 1 – Connect the Tablet/Laptop to the home's WiFi network (**Internet access is required**).

Step 2 – Open a browser on the Tablet/Laptop (Safari/Chrome) and go to intuity.legrand.us/provisioning.

Step 3 – Enter the User name (“installer”) and the password as (“PASSWORD”).

Step 4 – Save the webpage (example screen shown below) as a Home Screen link on the Tablet/Laptop (or bookmark the link via the browser). This will make for easy access to this page for future WiFi Bridge installations.

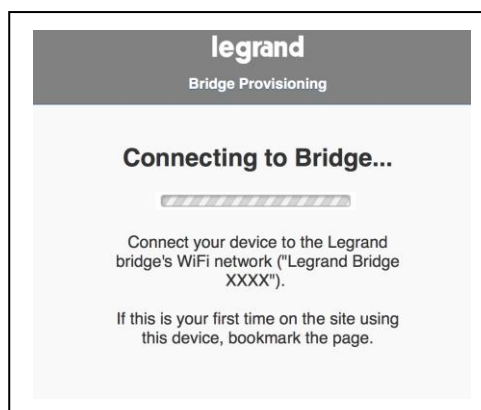

Step 4a - Move the Tablet/Laptop within 10' of the Bridge.

Step 4b – Go to the WiFi settings on the Tablet/Laptop and search for the Legrand Bridge (as shown below). **Note: The Bridges name can be found on the label on the back of the Bridge itself.**



Step 4c – Select the Legrand Bridge and enter the Bridge’s WiFi password (“PASSWORD”) to connect the Tablet/Laptop to the Bridge.



Step 5 – From the Tablet/Laptop, return to the bookmarked webpage from Step 3. The webpage will automatically go to the provisioning page.

Step 6- Select the home’s WiFi network from the list that is displayed (as shown below).

IMPORTANT: The Home’s WiFi (SSID) must be visible in order to pair bridges.

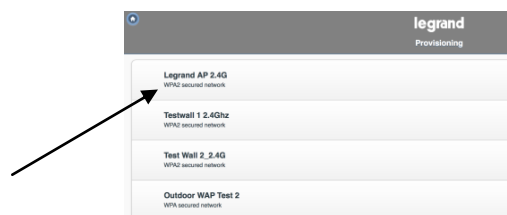

Step 7 - Enter the home’s WiFi password and click “Connect” (as shown below). Select “Unmask Password” if you wish to see the password as you type it.

Step 8 – The Bridge will now be provisioned to the home network and the middle LED on the Bridge will appear solid white once provisioned.

NOTE: If the Home's WiFi password is entered incorrectly, the Bridge will need to be reset to factory default. There is no visual indication on the User Interface (except the middle LED on the Bridge will not change to solid and will continue to blink rapidly). (Refer to Appendix A1)

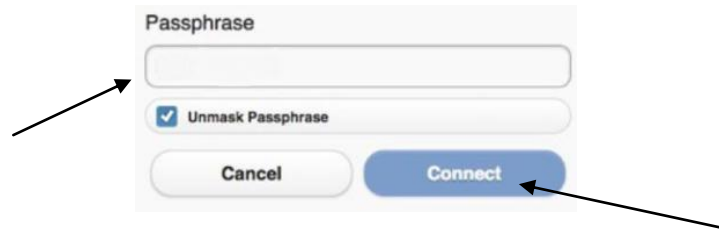

NOTE: Don't forget to change the Notebook, Tablet, or Laptop's WiFi back to the Home's WiFi network once the provisioning process is complete.

NOTE: If the SSID or WiFi Password is changed in the Home, the WiFi Bridge will need to be reset to factory default and re-provisioned with the new SSID or Password. (Refer to [Appendix A1](#))

NOTE: It is highly recommended that the Bridge firmware is updated to the latest version for best WiFi functionality. For directions on how to update the Bridges to the latest firmware, please see Support Bulletin P/N [SB035](#) available on the <http://legrand.us> website. ** As of Intuity release 2.1.1, bridge updates will happen automatically and will not require manual updating. **

6.1.2 Add a WiFi to RFLC Bridge to Intuity

Step 1 - To add the WiFi to RFLC Bridge to the Intuity system, first House Bind and Group Bind all RFLC devices in the home.

Step 2 - Open the home page of the browser and click on “Device Assistant” (1), then click “Add Device” (2) and then click “Add Manually” (3).

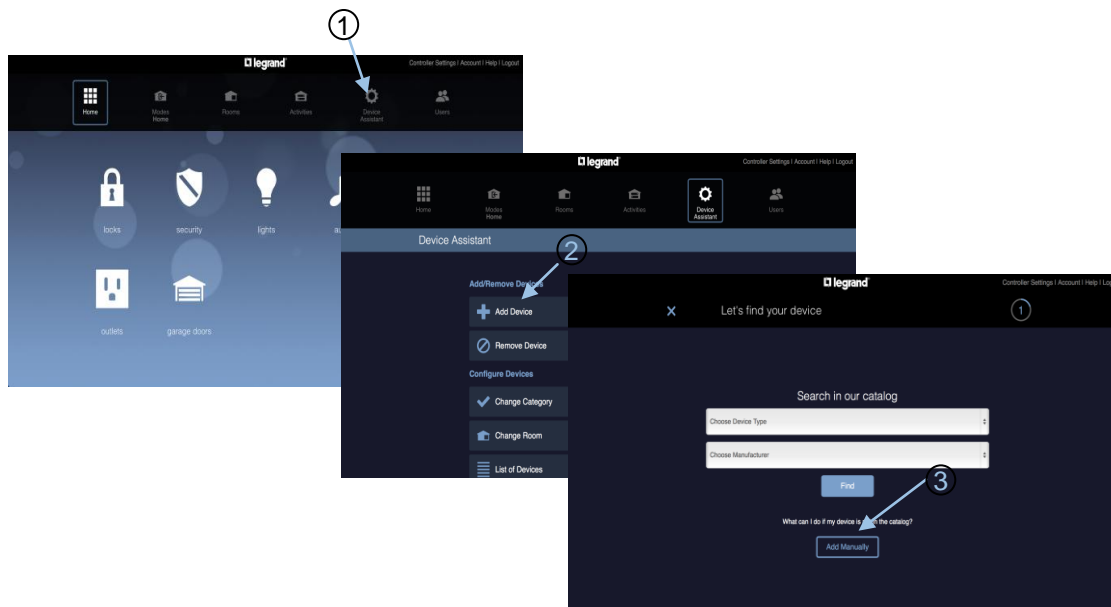

Step 3 - Tap on the “WiFi to RFLC Bridge” Adapter and go to the physical RFLC Bridge and press the Connect button.

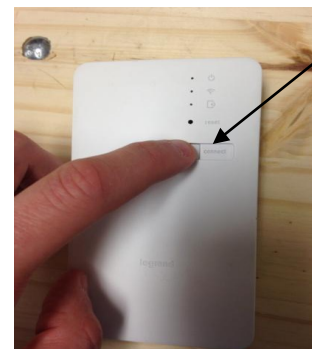
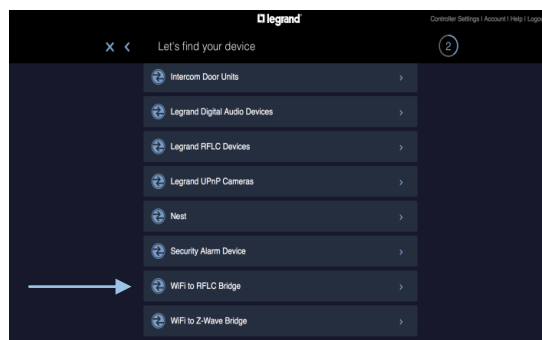

Step 4 - Wait 5 seconds, and click the “Add” button. This will allow time for the WiFi Bridge to announce itself on the network. The discovery process will automatically time out after 60 seconds. If the device does not discover, please wait for the timeout, then try again.

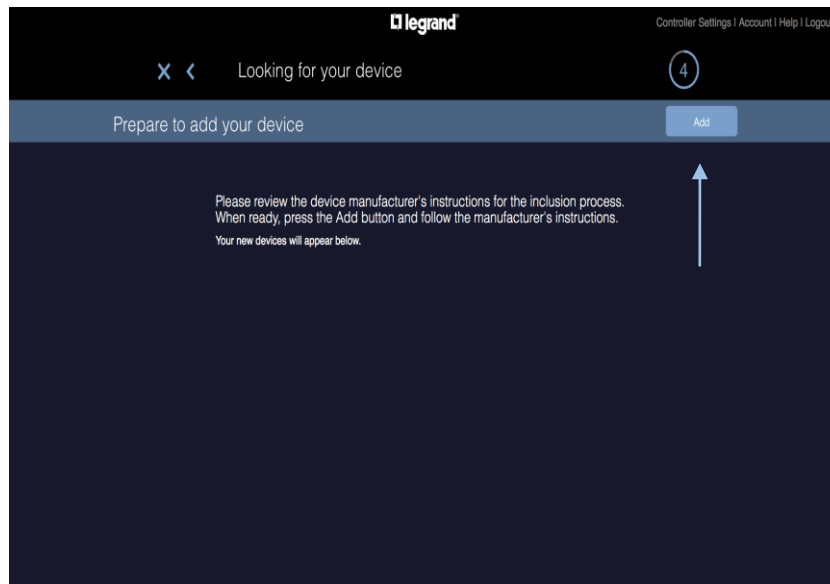

A “Searching for WiFi to RFLC Bridge devices” prompt should appear and within 10 seconds the “Operation Completed Successfully” prompt should appear.

Step 5 - Click “Done”. The bottom “Hub” LED on the Bridge should be lit solid white (Bridge is now paired to the Intuity system).

6.1.3 Add RFLC Devices

Step 1 - Get the House ID for the RFLC lights by clicking “Device Assistant” / “List of Devices” / “Legrand RFLC Device Adapter”.

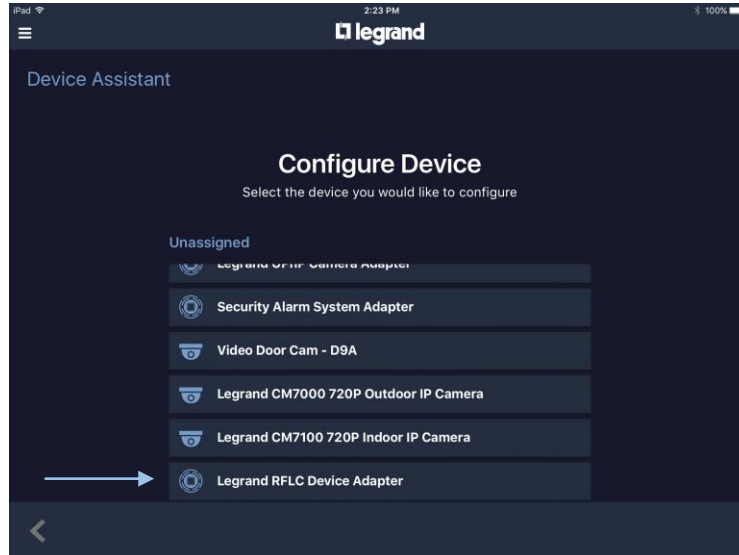

Step 2 - Scroll Down and click on “Get House ID”.

Step 3 - Go to an RFLC Dimmer/Switch and turn it on and off.

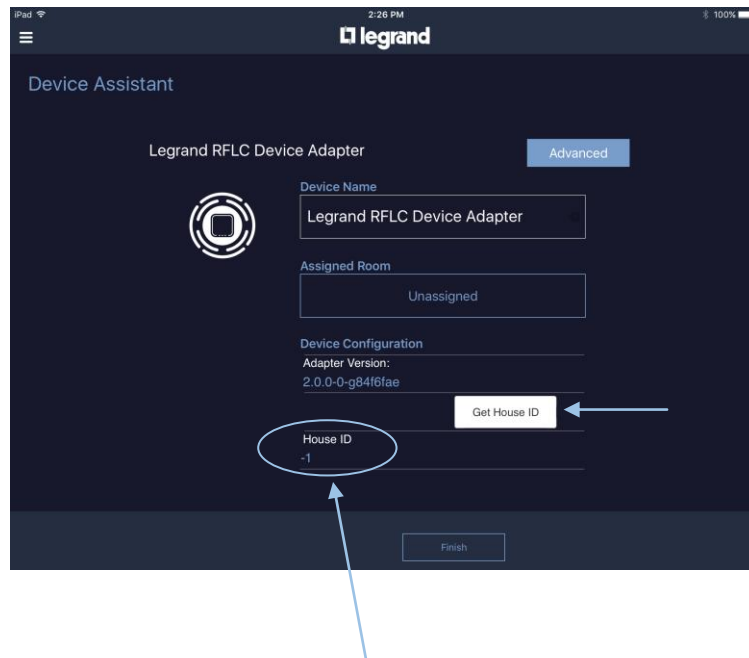

The House ID should have changed from a “-1” to a new number.

Step 4 - Click "Finish" and return to the "Device Assistant".

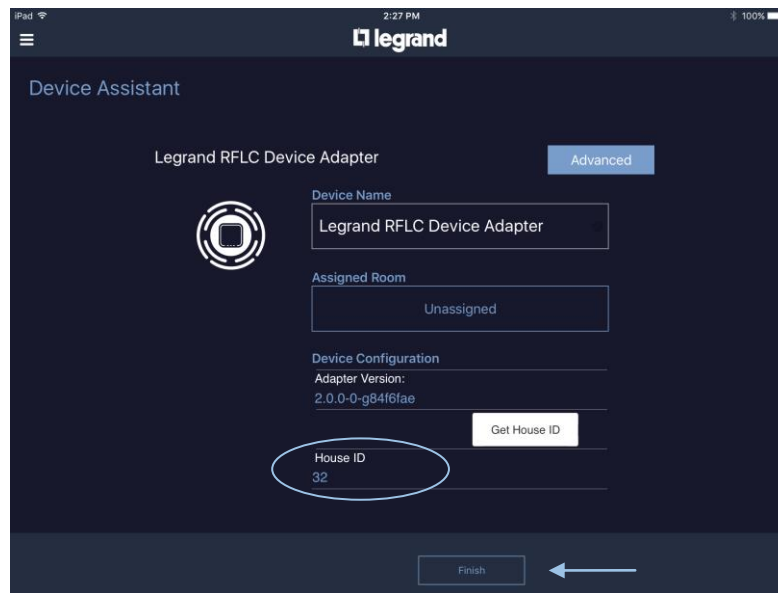

Step 5 - Tap on "List of Devices" and the Dimmer/Switch turned on/off will appear with an ID number XX:XX:XX:XXX. Rename this device and assign it to a room.

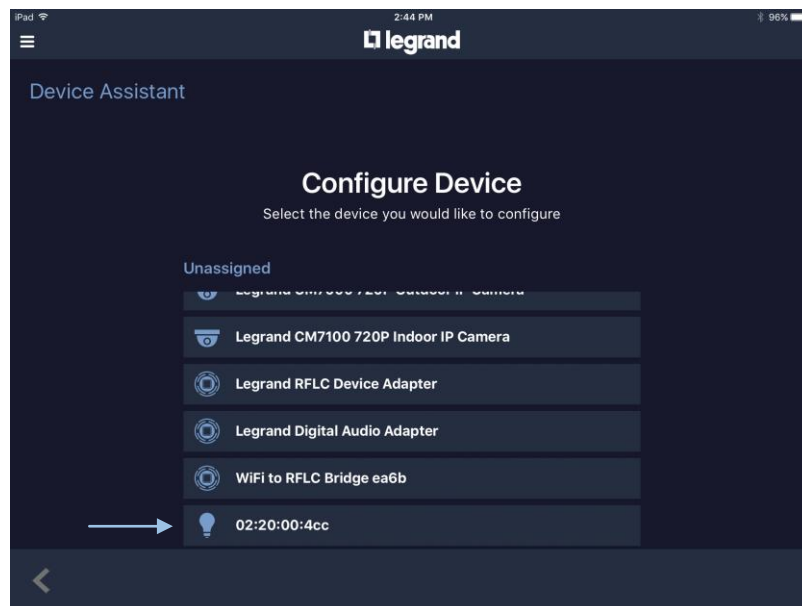

Step 6 - Go to another Dimmer/Switch and tap it two times, then go back to the List of Devices, refresh the screen and it will appear, waiting to be renamed and assigned a room.

Repeat Step 6 for all Master Dimmer/Switches. (Devices connected to a load).

NOTE: 3-Way Dimmer/Switch devices do not need to be added to the system - only Master Dimmer/Switches. 3-Way Dimmer/Switch devices should be group bound to the master switches prior to the addition of any RFLC lighting devices to the Intuity System. If a Remote device is added by accident, simply go to the Device Assistant > Remove Devices and remove that device.

NOTE: Standard On/Off Switches will appear under the “Outlets” page in the Intuity System by default. The device type can be changed by selecting the switch under the list of devices and changing its device type to “Light”. The switch will now appear properly in the “Lights” page.

6.1.4 Scene Controllers

The Intuity Home Automation System is now compatible with the adorne Scene Controller (part numbers ADTPRIWHCW1, ADTPRIWHCM1, ADTHRIWHCW1, ADTHRIWHCM1) and the radiant Scene Controllers (part numbers LC2303-WH, LC2303-LA and LC2303-NI).

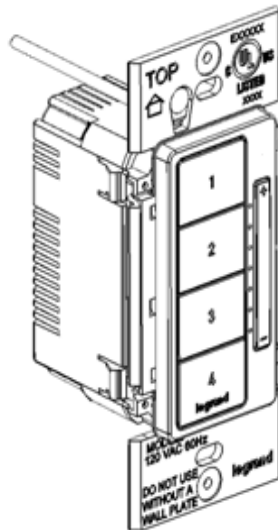

radiant Style

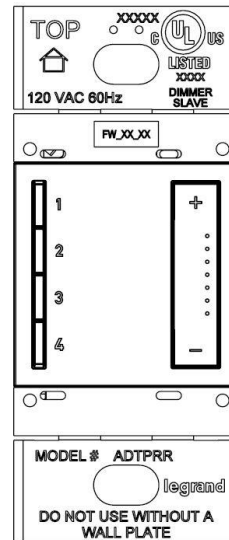

adorne SoftTap

The new Scene Controllers can be added to the Intuity Home Automation System by using the same steps provided in Section [6.1.3 Add RFLC Devices](#) . The addition of a scene controller to the Intuity Home System will allow for the buttons on the device to function as device triggers for an activity. Please refer to Section [8.0 Creating Activities](#) for more information. For further instructions on how to create an activity using the Scene Controller, please refer to the Intuity User Guide (P/N [1308241](#)).

6.2 Adding a WiFi to Z-Wave Bridge

The WiFi to Z-Wave Bridge will act as a WiFi Hotspot when first connected to power. Its SSID is Legrand Bridge XXXX (XXXX are the last 4 digits of its MAC address which can be found on the label on the back of the unit). The top LED is the power LED and will be on solid (white) when power is applied. The middle LED is WiFi, and it should be blinking slowly at this point. The bottom LED is the Hub LED and will be off at this point.



6.2.1 Access Website and Provision Bridge

Step 1 – Connect the Tablet/Laptop to the home’s WiFi network (**Internet access is required**).

Step 2 – Open a browser on the Tablet/Laptop (Safari/Chrome) and go to intuity.legrand.us/provisioning.

Step 3 – Enter the User name (“installer”) and the password as (“PASSWORD”).

Step 4 – Save the webpage (example screen shown below) as a Home Screen link on the Tablet/Laptop (or bookmark the link via the browser). This will make for easy access to this page for future WiFi Bridge installations.

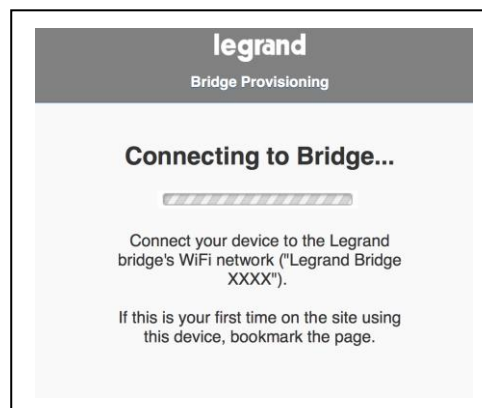

Step 4a - Move the Tablet/Laptop within 10' of the Bridge.

Step 4b – Go to the WiFi settings on the Tablet/Laptop and search for the Legrand Bridge (as shown below). Note: The Bridges name can be found on the label on the back of the Bridge itself.



Step 4c – Select the Legrand Bridge and enter the Bridge’s WiFi password (“PASSWORD”) to connect the Tablet/Laptop to the Bridge.

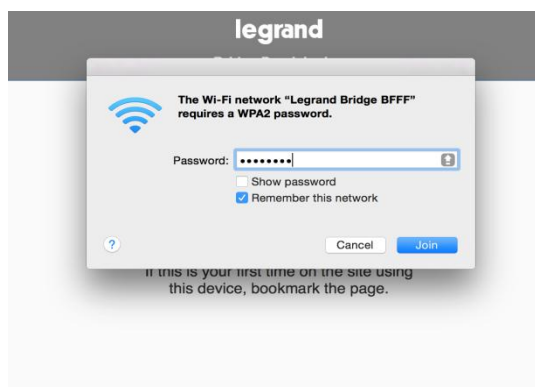

Step 5 – From the Tablet/Laptop, return to the bookmarked webpage from Step 3. The webpage will automatically go to the provisioning page.

Step 6- Select the home’s WiFi network from the list that is displayed (as shown below).

IMPORTANT: The Home’s WiFi (SSID) must be visible in order to pair bridges.

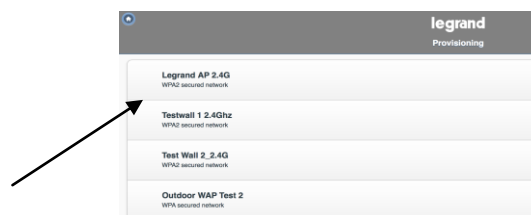

Step 7 - Enter the home’s WiFi password and click “Connect” (as shown below). Select “Unmask Password” if you wish to see the password as you type it.

Step 8 - The Bridge will now be provisioned to the home network and the middle LED on the Bridge will appear solid white once provisioned.

NOTE: If the Home's WiFi password is entered incorrectly, the Bridge will need to be reset to factory default. There is no visual indication on the User Interface (except the middle LED on the Bridge will not change to solid and will continue to blink rapidly). (Refer to Appendix A1)

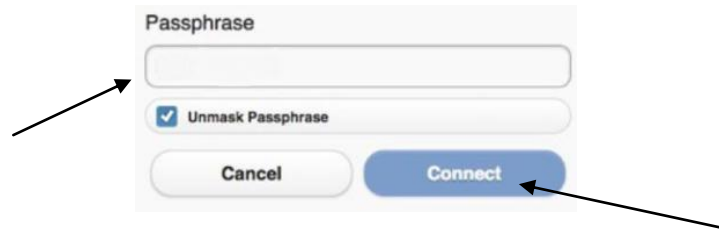

NOTE: Don't forget to change the Notebook, Tablet, or Laptop's WiFi back to the Home's WiFi network once the provisioning process is complete.

NOTE: If the SSID or WiFi Password is changed in the Home, the WiFi Bridge will need to be reset to factory default and re-provisioned with the new SSID or Password. (Refer to Appendix A)

NOTE: It is highly recommended that the bridge firmware is updated to the latest version for best WiFi functionality. For directions on how to update the bridge to the latest firmware, please see Support Bulletin P/N [SB035](http://legrand.us) available on the <http://legrand.us> website. ** As of Intuity release 2.1.1, bridge updates will happen automatically and will not require manual updating. **

6.2.2 Add WiFi to Z-Wave Bridge to Intuity System

Step 1 - To add the WiFi to Z-Wave Bridge to the Intuity System, open the home page of the web browser. Click on "Device Assistant" (1), then click "Add Device" (2), and then click "Add Manually" (3).

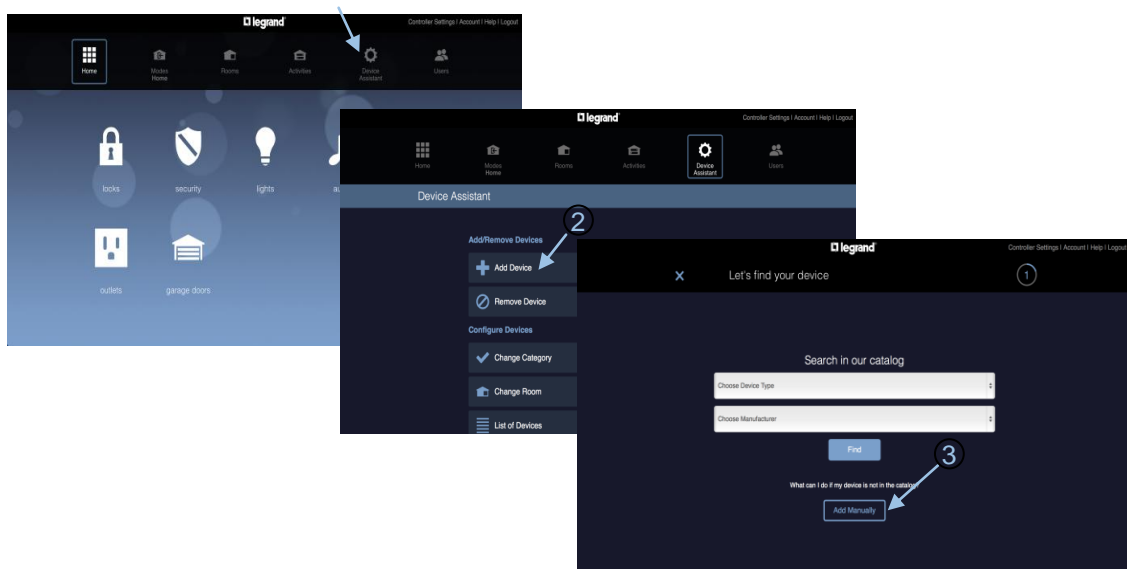

Step 2 – Click on the WiFi to Z-Wave Bridge Adapter and go to the physical Z-Wave Bridge and press the Connect button.

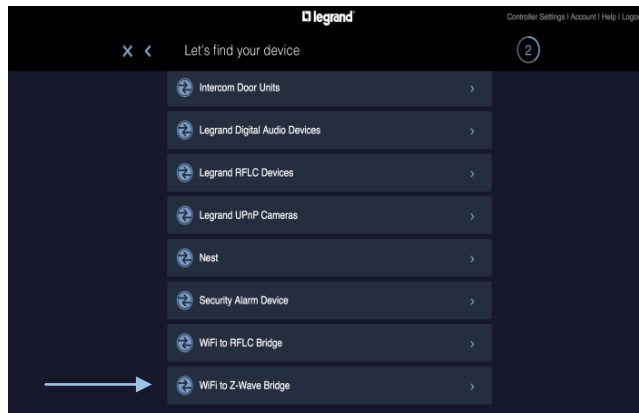

Step 3 - Wait 5 seconds and click the “Add” button. This will allow time for the WiFi Bridge to announce itself on the network. The discovery process will automatically time out after 60 seconds. If the device does not discover, please wait for the timeout, then try again.

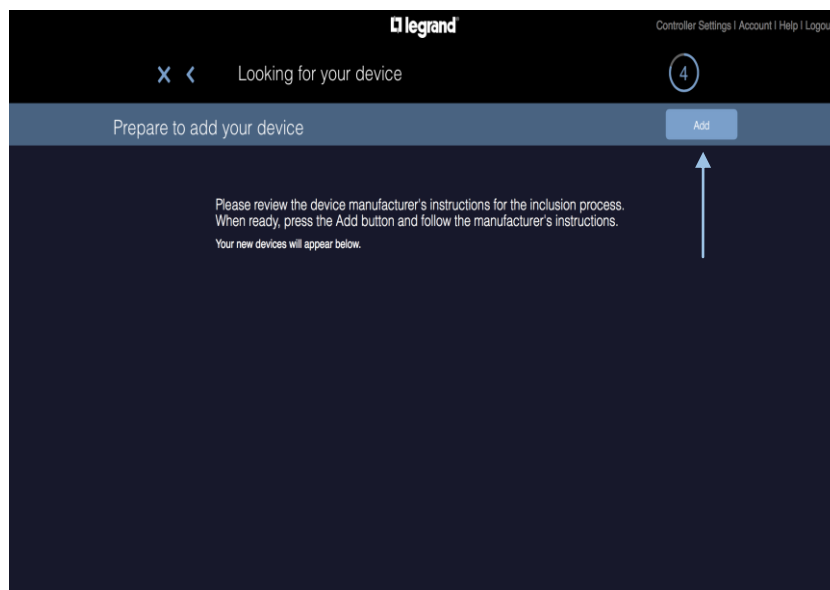

A “Searching for WiFi to Z-Wave Bridge Devices” prompt should appear and within 10 seconds the “Bridge added” prompt should appear.

Step 4 - Just press “Done” and the bottom LED on the Bridge should be lit solid (Bridge is now paired to Intuity system). When completed, all three LED’s on the bridge will be solid white.

6.2.3 Removing Z-Wave Device ID

Step 1 - Before adding Z-Wave devices, it is best practice to first remove any previous Z-Wave ID from the Z-Wave device. Go to “Device Assistant”, select the WiFi to Z-Wave Bridge and scroll down to click on “Begin Remove”.

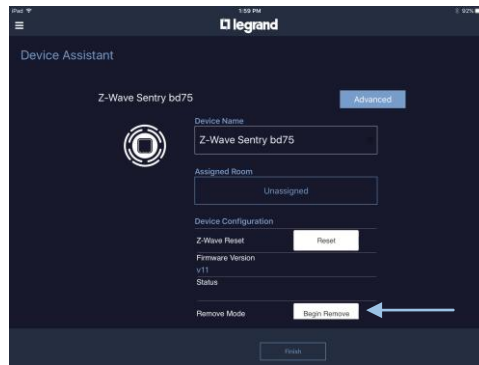

NOTE: It is not uncommon for brand new Z-Wave Locksets to have Z-Wave IDs from the factory that must be cleared, which is why it is important to follow these steps. Each Z-Wave device will have a different method for removing its Z-Wave ID. Below is an example of removing the Z-Wave ID from a popular brand Lockset.

Step 2 - After pressing “Begin Remove”

Notice the prompt “Waiting for device to be Pressed”

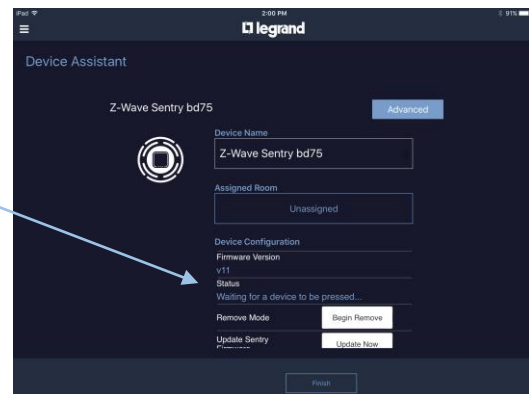

Step 3 - Go to the device and press its pairing button.

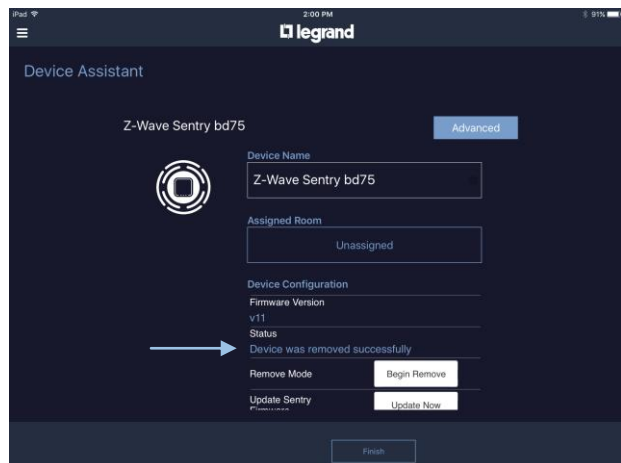

Notice the prompt. The prompt shows that it was successfully removed.

Repeat Steps 1-3 for all Z-Wave devices.

6.2.4 Adding a Z-Wave Device to Intuity

To add Z-Wave devices, first refer to the third party manufacturer documentation on how to put their device (locksets/thermostats/garage door/Z-Wave range extenders) into pairing mode.

1. Prepare to put the third party Z-Wave device into pair mode (do not put it into pairing mode yet).
2. From the Intuity App, select the “Device Assistant” > “Add Device” > “Manual Addition” > “WiFi to Z-Wave Bridge”
3. Press the “Add” button in the Intuity App, then wait for the screen to display “listening for Z-Wave device to add”
4. Put the third party Z-Wave device in pairing mode.
5. A “Searching for Z-Wave Device” prompt should appear.
6. Within 30 seconds the “Z-Wave Device added” prompt should appear.
7. Press Done. Name the new device, and assign it to a Room

NOTE: Z-Wave locks lose their User Passcode after being added to the system or clearing their Z-Wave ID (using “Begin Remove”). If an installer sets up the Z-Wave lock, they will need to have the homeowner program the Passcode back into the Z-Wave lock.

NOTE: If adding a lockset, wait 2 minutes before performing a Lock / Unlock command.

NOTE: For a list of compatible third party Z-Wave devices, please visit our Intuity Third Party Systems page at: <http://www.legrand.us/home-automation/intuity-third-party-systems>

6.3 Adding Wireless Thermostats

6.3.1 Add a WiFi Thermostat to the Intuity System

For Honeywell WiFi Thermostat:

Before beginning, install and configure the WiFi thermostat on the Honeywell website per instructions supplied by Honeywell with the thermostat.

NOTE: Air Conditioning (AC) MUST be enabled in the Honeywell WiFi thermostat settings before it can be properly added to Intuity.

Open the home page of the browser and click on “Device Assistant” (1), then click “Add Device” (2) and click “Add Manually” (3).

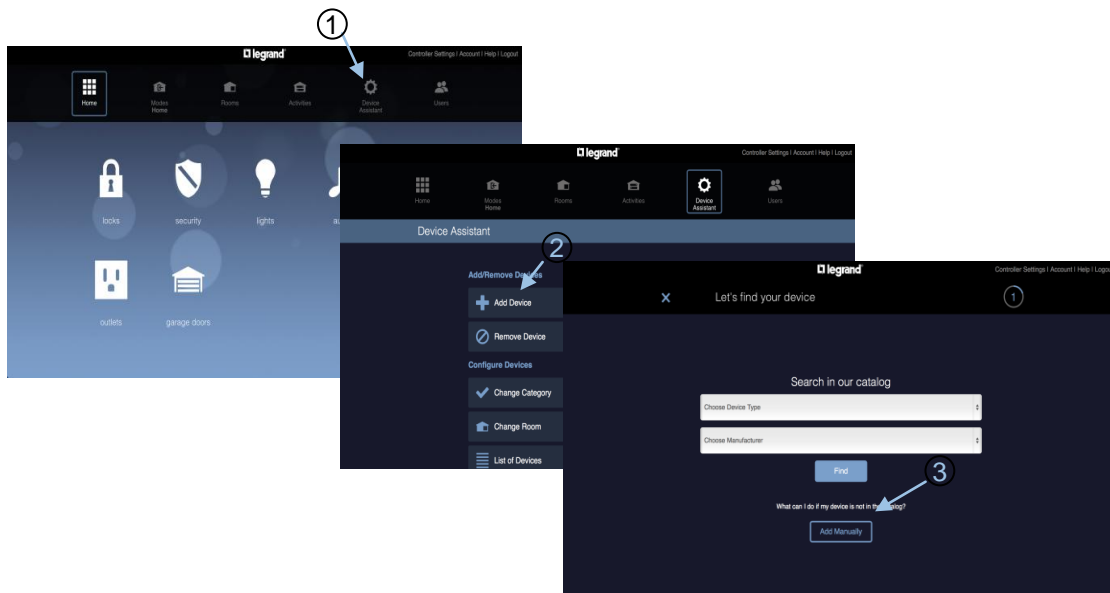

Select the “Honeywell WiFi Thermostat” Adapter, and press the “Add” button.

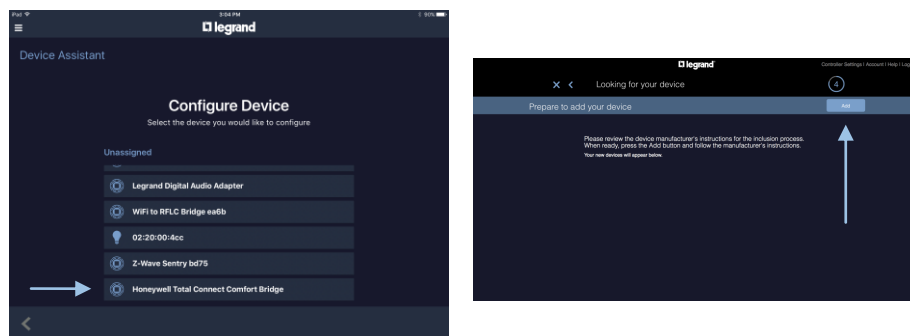

When the Status screen says “Finished Search...” Press “Done”.

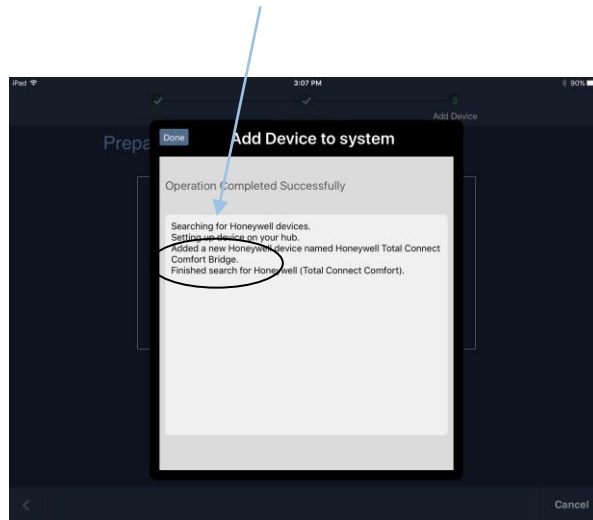

Select “Configure Device”. Enter the login credentials for the Honeywell thermostat and press “Add All”.

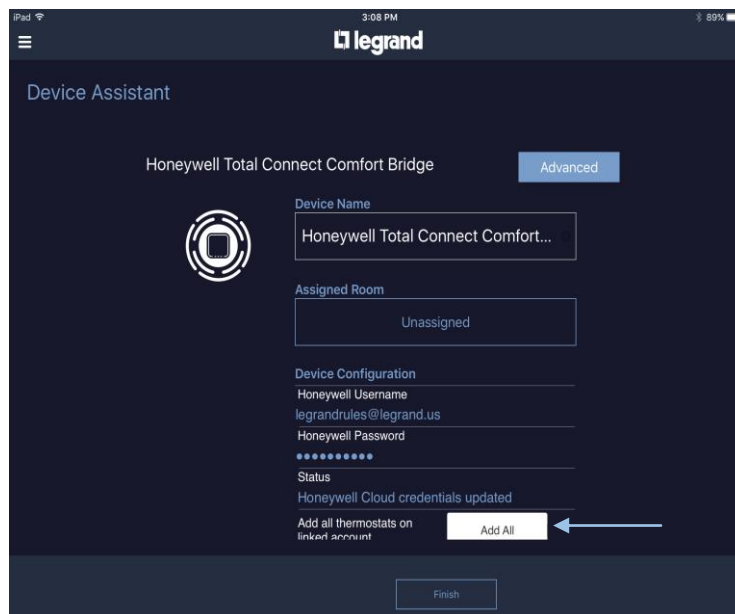

For Honeywell Prestige IAQ 2.0 (RedLINK):

The following procedure outlines the standard configuration of the Honeywell Prestige® IAQ 2.0 Thermostat for use with the Legrand Intuity Home Automation System. Equipment installation will be in accordance with the instructions provided by Honeywell.

Deadband Setup for Intuity:

A/C with Low Speed Fan

Setup 1 (if Overcooling Limit is set to 1°)

1. Menu>Installer options>[Installer Code]>View/Edit Current Setup
2. View/Edit Current Setup>Dehumidification>Dehumidification Equipment>**A/C with Low Speed Fan**>[Done]
3. View/Edit Current Setup>Dehumidification>Dehumidification - Overcooling Limit: X°>**1°**>[Done]
4. View/Edit Current Setup>Heat/Cool Control Options>Deadband: X°>**2°**>[Done]
5. Return to the Main Menu. Setup Complete.

Setup 2 (if Overcooling Limit is set to 0°)

1. Menu>Installer options>[Installer Code]>View/Edit Current Setup
2. View/Edit Current Setup>Dehumidification>Dehumidification Equipment>**A/C with Low Speed Fan**>[Done]
3. View/Edit Current Setup>Dehumidification>Dehumidification - Overcooling Limit: X°>**0°**>[Done]
4. View/Edit Current Setup>Heat/Cool Control Options>Deadband: X°>**3°**>[Done]
5. Return to the Main Menu. Setup Complete.

A/C with High Speed Fan

Setup 3

1. Menu>Installer options>[Installer Code]>View/Edit Current Setup
2. View/Edit Current Setup>Dehumidification>Dehumidification Equipment>**A/C with Low Speed Fan**>[Done]
3. View/Edit Current Setup>Dehumidification>Dehumidification - Overcooling Limit: X°>**1°**>[Done]
4. View/Edit Current Setup>Heat/Cool Control Options>Deadband: X°>**2°**>[Done]
5. Return to the Main Menu. Setup Complete.

Whole House

Setup 4

1. Menu>Installer options>[Installer Code]>View/Edit Current Setup
2. View/Edit Current Setup>Dehumidification>Dehumidification Equipment>**Whole House**>[Done]
3. View/Edit Current Setup>Heat/Cool Control Options>Deadband: X°>**3°**>[Done]
4. Return to the Main Menu. Setup Complete.

Next, create a Honeywell User account. Follow the instructions given in the RedLINK Internet Gateway Instruction manual to create an account at <http://www.mytotalconnectcomfort.com>.

Adding the Honeywell Thermostats to the Intuity Home Automation System:

1. Log into the Intuity account using the Web Browser
2. Go to **Device Assistant>Add Device>Add Manually>Honeywell WiFi Thermostat>Add**
3. Go to **Device Assistant>List of Devices>Honeywell Total Connect Comfort Bridge**
4. Enter the Username and Password credentials for the Honeywell user account.

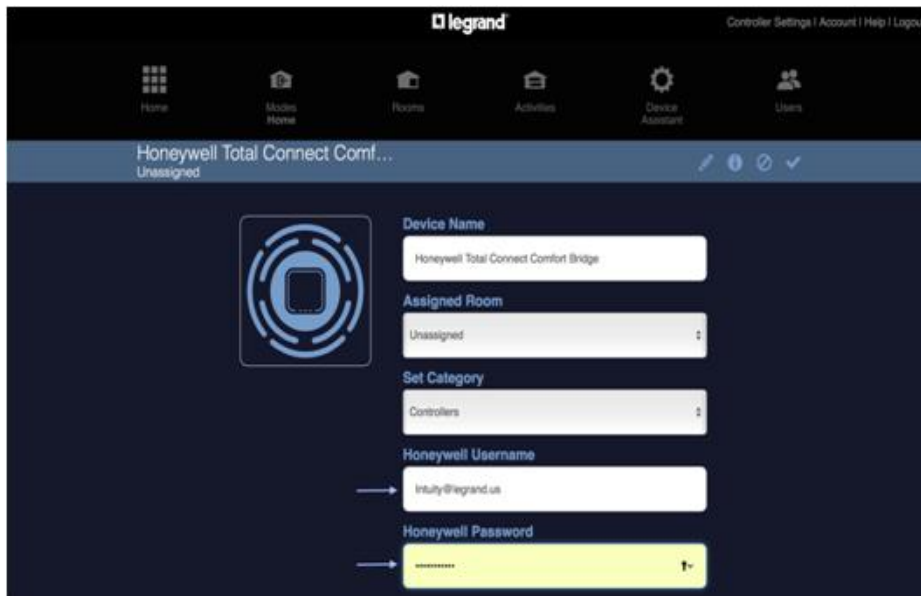

The screenshot shows the Legrand Intuity web interface. At the top, there is a navigation bar with icons for Home, My Home, Rooms, Activities, Device Assistant, and Users. Below this is a header for 'Honeywell Total Connect Comfort Bridge' with a status of 'Unsigned'. The main content area contains a form with the following fields:

- Device Name:** Honeywell Total Connect Comfort Bridge
- Assigned Room:** Unsigned
- Set Category:** Controllers
- Honeywell Username:** Intuity@legrand.us
- Honeywell Password:** [Redacted]

5. At the bottom of the screen, select the “Add All” option. The status will indicate the number of devices added to the Intuity System. All individual thermostats on the Honeywell user account will be added to the system at this time.

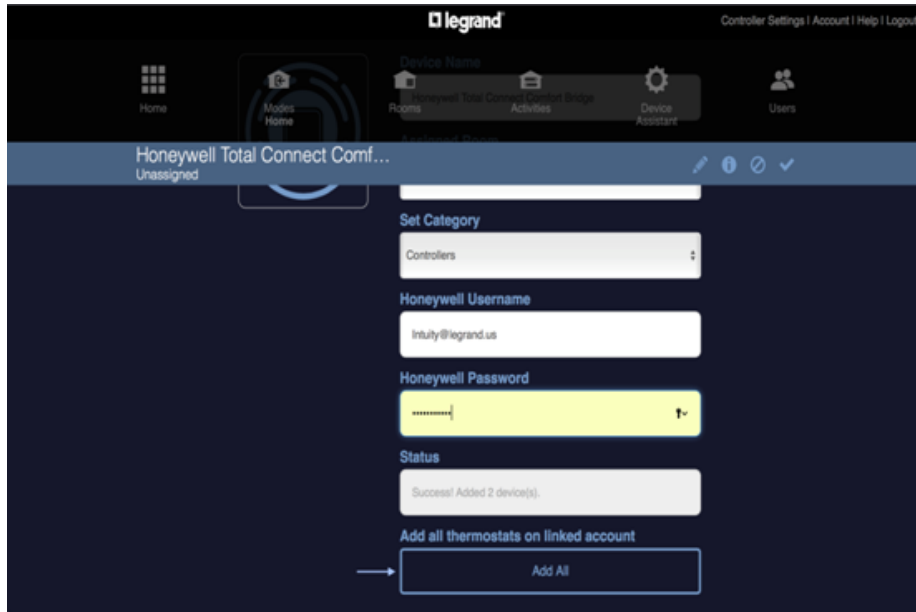

6. Verify that all thermostats have been added under the Thermostats tile from the main page of the app.

7. Individual thermostats that the user does not want to appear in the app can be removed. Go to **Device Assistant>Remove Device>Honeywell WiFi Thermostat>[Thermostat Name]**

NOTE: The Thermostat Temperature Sensor associated with the thermostat will be removed when the thermostat is removed in this step. No further action is required.

For NEST Thermostat:

Before beginning, install and configure the Nest Thermostat(s) according to the instructions included with the device.

NOTE: Make sure that the Nest Thermostat is connected via WiFi to the same network in the home as the Intuity Controller.

Then open the main page of the browser and tap on “Device Assistant” (1), then tap “Add Device” (2) and then tap on “Add Manually” (3).

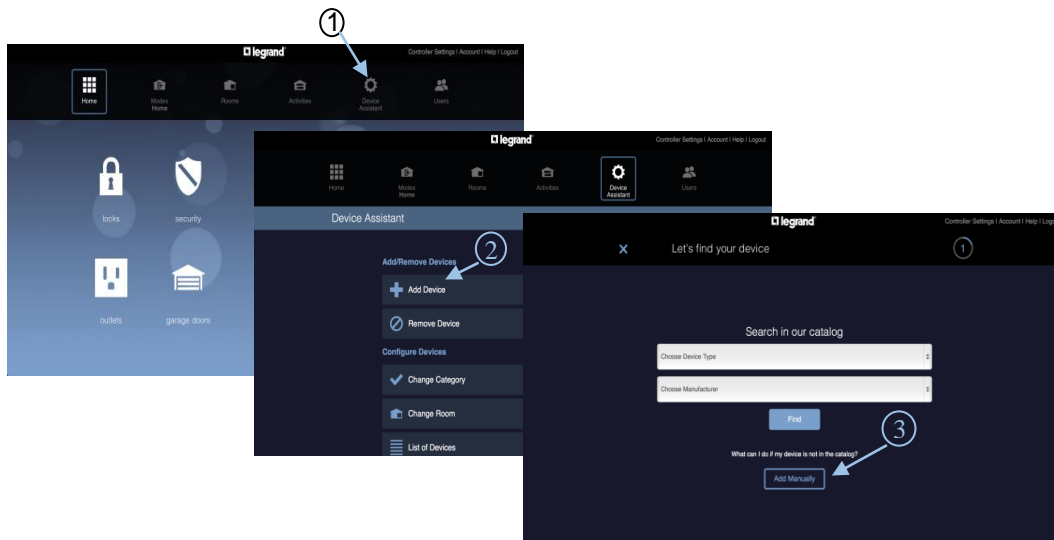

Select the “NEST” Adapter, and press the “Add” button.

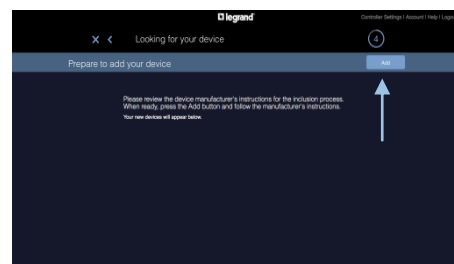

Next, walk through the steps to pair the Nest Thermostat(s) with the Nest app. Instructions on how to do so will be supplied with thermostat. This step will require an account to be created with Nest. Once the username and password has been registered with Nest, press the “Authorize” button in the Intuity app to allow the Intuity Controller to connect to the Nest Thermostat(s).

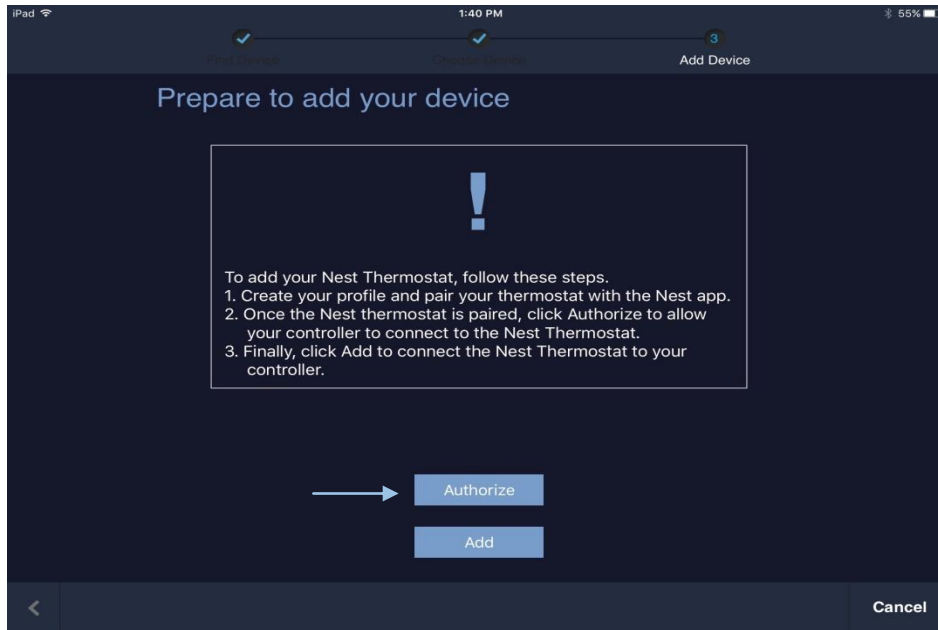

At this time, a prompt will appear in the app asking for authorization to allow for control of the Nest Thermostat(s). Press the “Accept” button to allow for control.

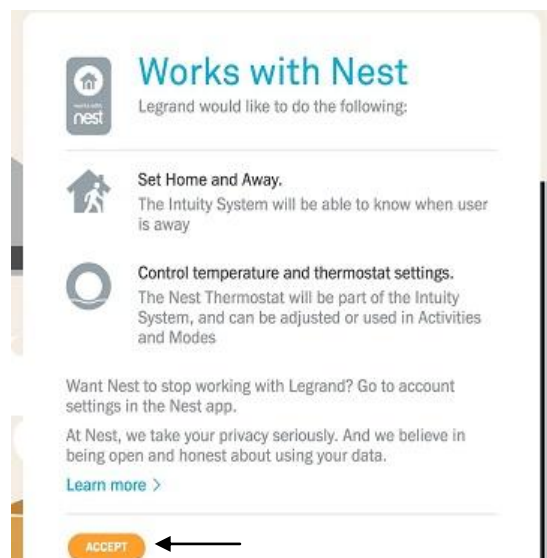

Next, you will be prompted to enter the account information for Nest. Enter the username and password that was created to pair the Nest Thermostat(s) with the Nest app. Press the “Sign In” button to proceed.

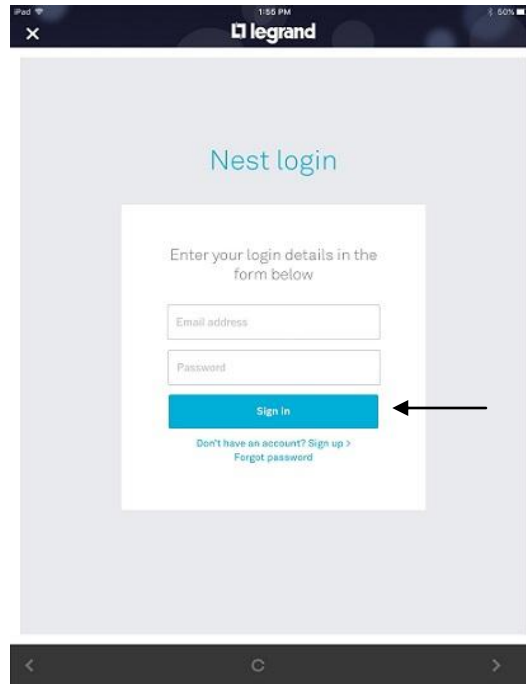

The Intuity system will confirm that the Nest Thermostat has now been authorized to communicate with the Legrand hub (the HA7000). Close the page to complete the authorization process by pressing the “X” icon.

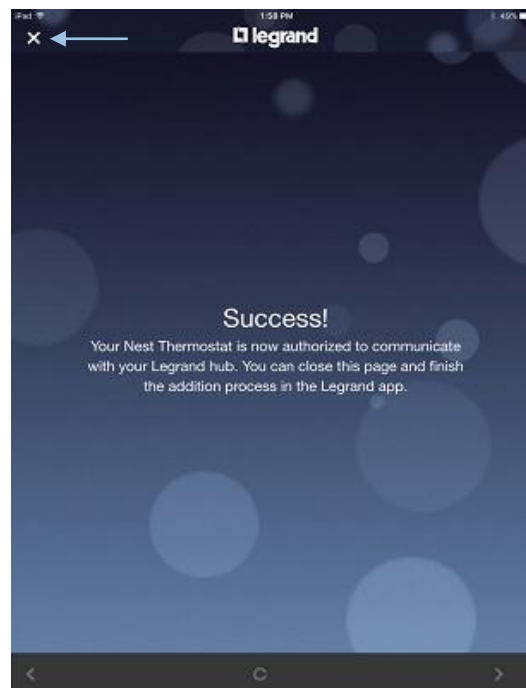

The final step is to add the Nest Thermostat(s) to the Intuity System. Press the “Add” button to begin the search process. The Intuity System will automatically discover the Nest Thermostat(s) on the network. Press the “Done” button to complete the installation.

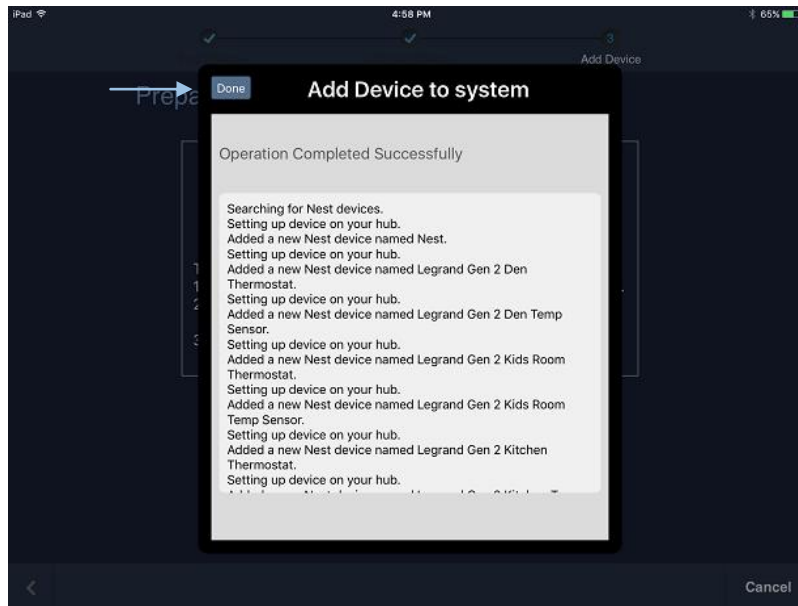
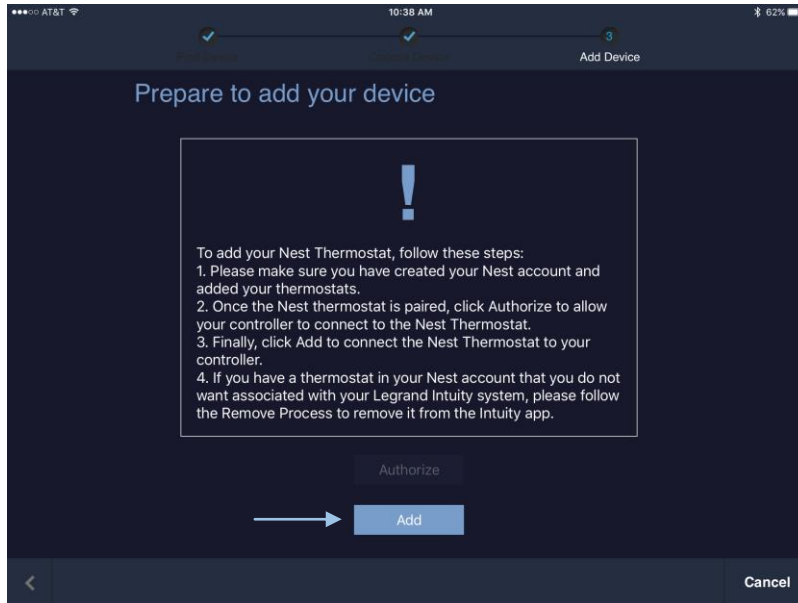

6.3.2 Add a Z-Wave Thermostat or Garage Door Opener to the Intuity System

To add a Z-Wave thermostat or garage door opener to the system, follow the instructions given in section 6.2.4 “Adding a Z-Wave Device to Intuity”.

6.4 Adding QMotion Shades

6.4.1 Prior to Adding Shades

Prior to commissioning the Intuity system, the QMotion shades must be pre-configured using the [QMotion Qube Coordinator](#). For best functionality, the shades should be controllable using the [QMotion Qube](#) app.

NOTE: The QMotion Qube app is only available as an iPhone app download. There is no iPad version of the app available and it will not appear in a search if the parameters are set for only iPad apps.

If you have questions concerning the configuration of the QMotion Shades using the Qube Coordinator, please contact QMotion Technical Support at 877-849-6070.

6.4.2 Adding Shades

Begin by opening the Intuity app. Select the “Shades” icon from the main screen.

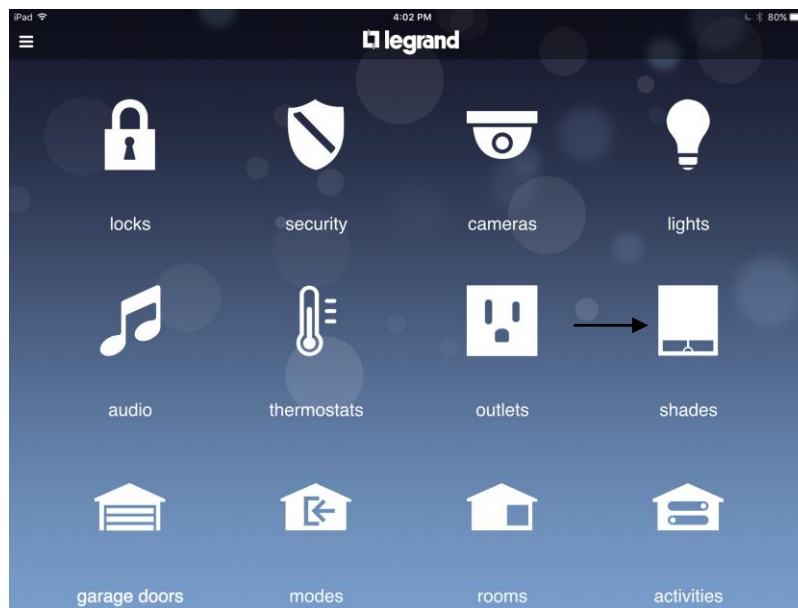

If the QMotion shades have been properly configured prior to Intuity being commissioned, all of the previously configured shades should appear automatically.

Verify that all of the shades are listed and are controllable in the menu screen.

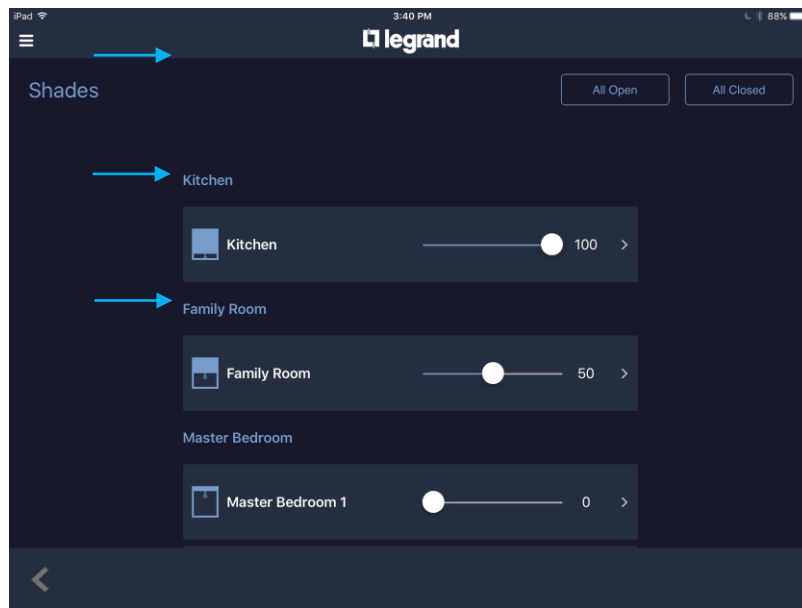

7.0 Adding Wired Devices

7.1 Adding a Security Subsystem

NOTE: Before adding a security system to Intuity, the security system must be installed and commissioned. Consult with your security alarm professional before making any changes to the security panel programming. It is important to understand what impact these programming changes may have on the rest of the security system devices.

Honeywell Vista 15p/20p/21ip:

1. Key in Installer Code (or 4112 by default) plus [800] to enter program and installer mode.
2. Then press [*][189] and then [5100], [*][192] [51], [*][193] [61], [*][91] [82] (not required with Vista firmware 10.23 or newer), [*][21] [11] [00] would keep Quick Arm enable off for both keypads and Intuity.
3. For the Honeywell Vista 15p, the codes would be [*][189] [55], [*][192] [51], [*][193] [51], [*][91] [82] (not required with Vista firmware 10.23 or newer), [*][21] [1] [0] would keep Quick Arm enable off for both keypads and Intuity.

NOTE: The default keypad address for Honeywell Vista series panels is 16. By default, Intuity uses keypad address 19 for partition 1 and keypad address 20 for partition 2. The steps described above will enable Intuity address 19 on partition 1 and Intuity address 20 on partition 2. If they keypad has no text on the display, check the wiring and if correct, set the address by power cycling the system, holding 1 and 3 on startup, then enter the address (16) followed by *.

Interlogix Concord 4:

1. Key in [8][Installer Code] (or 4321 by default), then press [0][0] to enter program and installer mode.
2. Then press [#] for system programming,
3. Press [#] for security, up/down to select the proper partition to configure and [#] to select.
4. Press up/down to select Quick Arm and [#] to select. [1] = off or [2] = on,
5. Press [#] to save, then [*][*][*], and up to select exit system programming and then [#].

Interlogix NetworX:

Program the NX-584 Automation Module according to its user manual (see page 10). To do so, from any keypad enter [*][8] + Go to Program Code (9173 default). Enter the address [72][#] for the NX-584. Use the following settings:

0. Option Flags – Use Default [Off = Binary]
 1. Baud Rate – 6 = 38400 [38.4k]
 2. Enabling the Transitions (2 Segments):

- Segment 1: Select options 2, 5, 6, 7, 8 (2 and 7 will be selected by default)
 - Segment 2: Use Default (1 and 2 will be selected)
3. Programming the Command/Request Enables (4 Segments):
 - Segment 1: Use Default (2, 4, 5, 6, 7 and 8 will be selected)
 - Segment 2: Use Default (1, 2, 3, 4, and 5 will be selected)
 - Segment 3: Use Default (1 will be selected)
 - Segment 4: Select options 4, 5, 6 and 7 (4 and 7 will be selected by default)
 4. LCD Keypad Address (1 Segment) – Use Default (Address 192)

Next, program the security panel according to the user manual. From any keypad enter [*][8] + Go to Program Code (9713 default). Enter the address 0# for the control panel. Finally, Location 23 – Segment 1- Enable option 1 to allow quick arm.

NOTE: For further assistance with Security Configuration, contact Legrand Technical Support or the Security System Installer.

DSC Power Series NEO:

This guide assumes that the programming in the panel is set to the default for all settings. The default installer's code is 5555. It also assumes that v5.0 of the Communicator is being used.

1. Enable the Alternate Communicator
 - From the keypad Enter [*][8][Installer Code]
 - Enter [382] to program communicator option 3
 - Scroll over to option 5 using the arrow keys and hit [*] enable
 - Enter [#] to save settings and back out to the main screen
2. Configure the Alternate Communicator
 - From the main programming screen enter [851] to program the alternate communicator
 - Enter [006] for the subsection System Toggle Option 2
 - Disable option 1 and 2 and enable option 8. Leave all other settings at their default level – The output should show - - 3 - - - - 8
 - Enter [#] to save settings and back out to the alternate communicator programming screen
 - Enter [422] for the subsection Integration Account Code
 - Write down the 12 digit number assigned to this communicator for use in configuring Intuity in the next step
 - Enter [#] to back out to the alternate communicator programming screen
 - Enter [423] for the subsection Integration Access Code
 - Program any 8 digit number in this section bt make sure to write it down for use in configuring Intuity in the next section

- **If using the TL280-RE Communicator Board** – Enter [425] and hit 1 on the keypad to enable Serial Communication.
- Enter [#][#][#] to save all settings and exit programming mode

NOTE: If using an older version of the communicator prior to v5.0, the number selection for accessing the Integration Account Code will be [651] and the selection for accessing the Integration Access Code will be [652].

NOTE: Using an older revision of the communicator may also affect compatibility with certain models of the DSC Power Series Neo Security Panels.

NOTE: After making the changes for the TL280RE Communicator board, it may be necessary to reboot the security controller before adding the security panel to the Intuity System.

To add the security subsystem to Intuity, open the home page of the browser and click on “Device Assistant” (1), then click “Add Device” (2) and then click “Add Manually” (3).

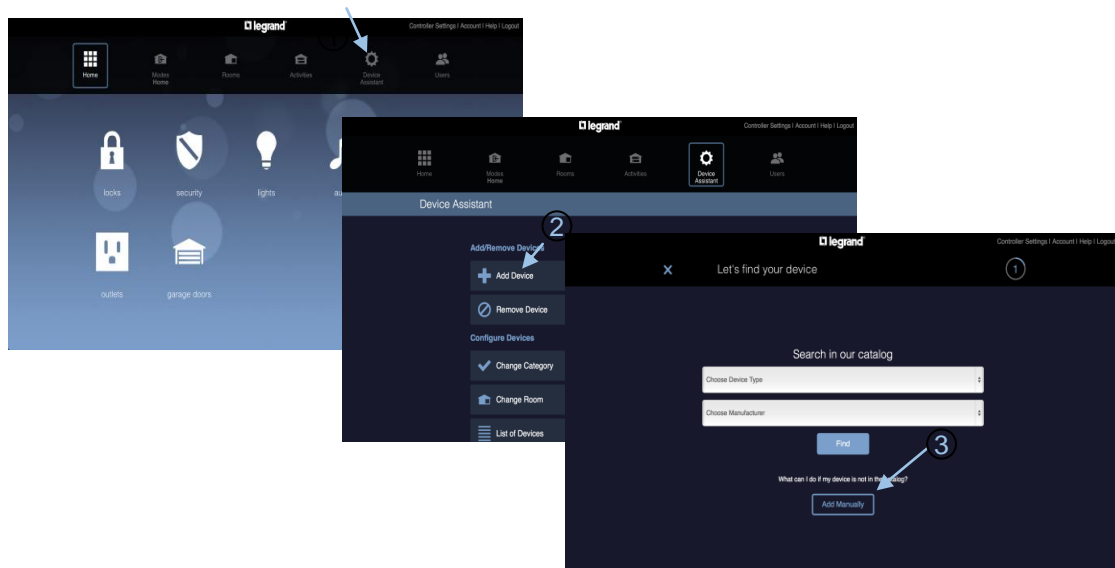

Click on “Security Alarm Device” adapter and then click “Add”.

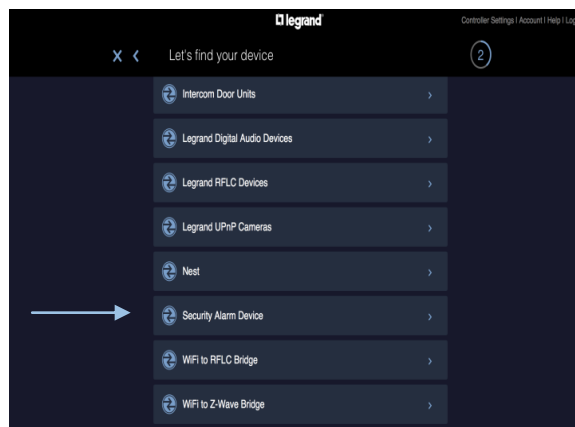

The security system will then be discovered and added to the “List of Devices”. Press “Done” to finish. The Intuity system will automatically configure all partitions and sensors that have been programmed on the Interlogix and Honeywell panels.

NOTE: For the DSC Power Series Neo the adapter will be installed but no zones or partitions will be added automatically. The Integration Account Code and Integration Access Code must be entered in the configuration page of the adapter. To complete the configuration:

1. Go to “Device Assistant” from the home page.
2. Select “List of Devices”.
3. Select the “Security Alarm Adapter”

4. Enter the 12 digit Integration Account Code
5. Enter the 8 digit Integration Access Code

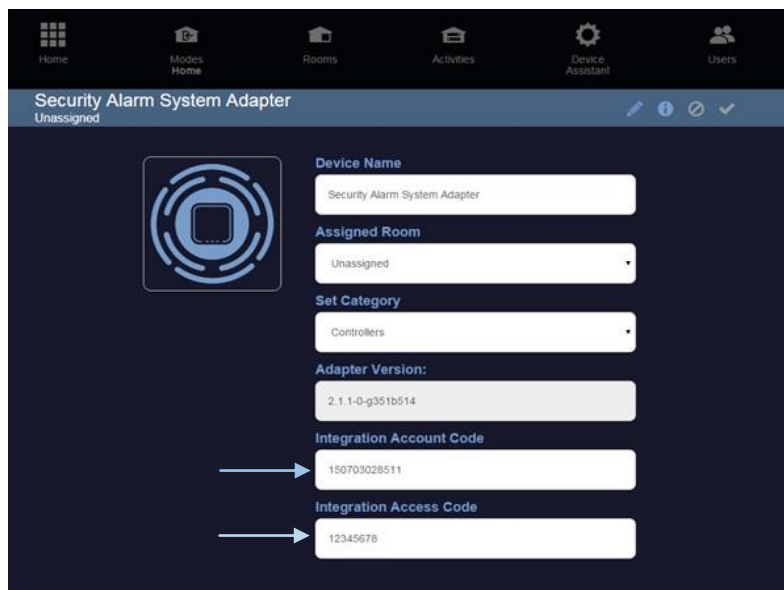

The final step is to add zones and partitions by going to Device Assistant – Add device – Add manually – Security Alarm Device and then selecting “Add”.

Complete the Configuration of the security system by assigning sensors to the rooms in which they reside. To enable “Quick Arm” and/or “Quick Disarm”, go to the “List of Devices” and Select the Partition.

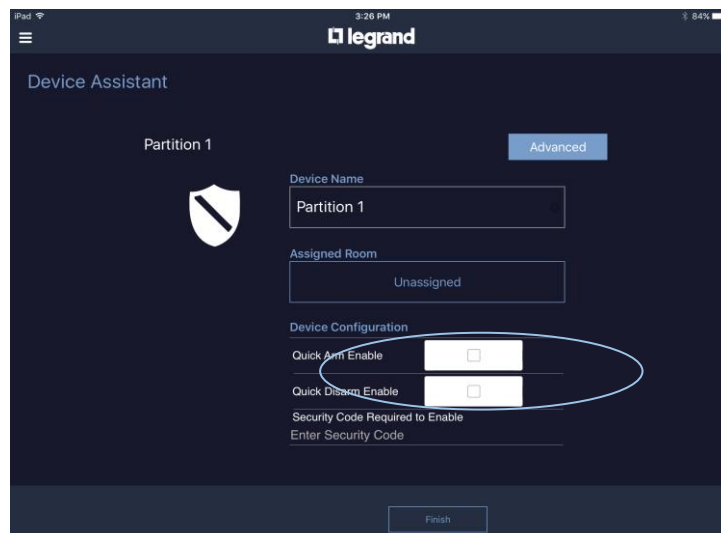

NOTE: If Quick Arm is enabled in the Intuity App, it must also be enabled in the security systems programming.

7.2 Adding IP Cameras

Legrand IP Cameras are UPnP devices. They are discovered and added automatically when attached to the Intuity System after 1-15 minutes.

NOTE: Cameras cannot be viewed from the Intuity web browser Interface.

7.2.1 Adding remote viewing to IP Cameras

To add remote viewing capability, open the home page and click on “Device Assistant”, then click “List of Devices” and select the camera.

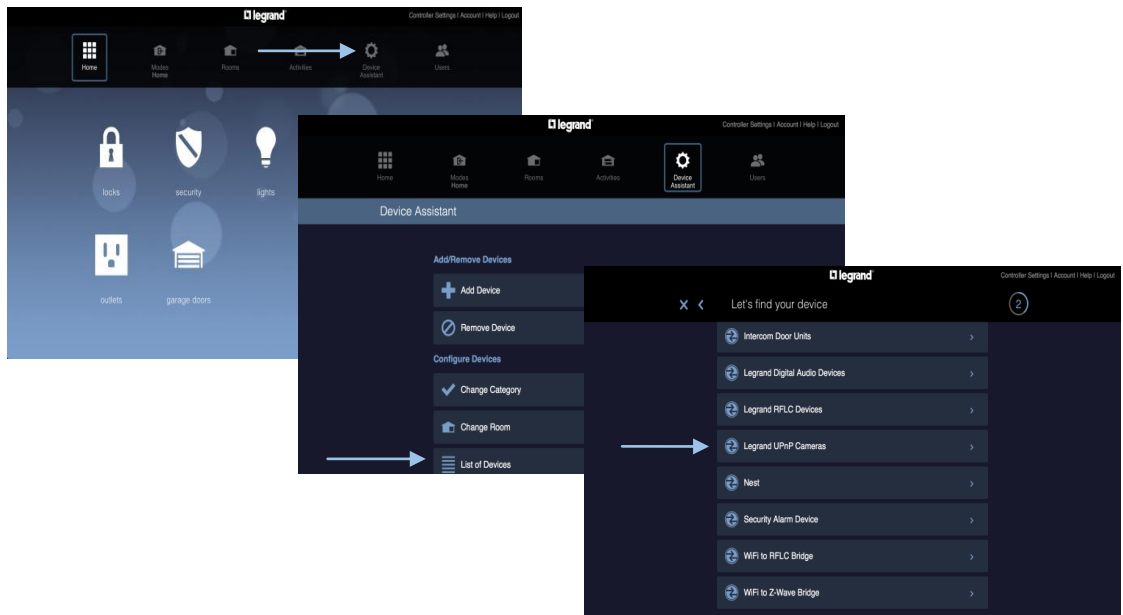

Go to the external port field and type in the port forwarding address (like 4498). This address must match the port forwarding setup in the router and the camera.

NOTE: Once setup for port forwarding, the cameras can be accessed by opening a second browser page and directly entering the Camera’s IP Address (for example 192.168.40.103). Remember to add the router port forwarding number (for example 192.168.40.103:8090).

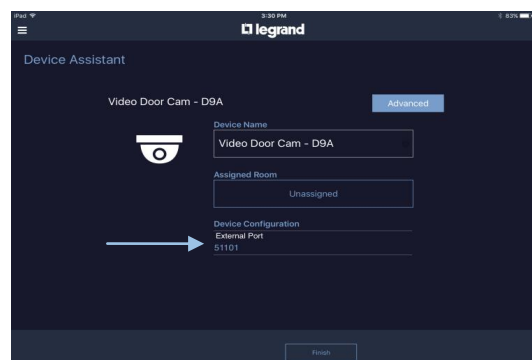

7.3 Adding a Digital Audio Subsystem

To add the Legrand Digital Audio subsystem to Intuity, from the home page of the browser click on “Device Assistant” (1), then click “Add Device” (2) and then click “Add Manually” (3).

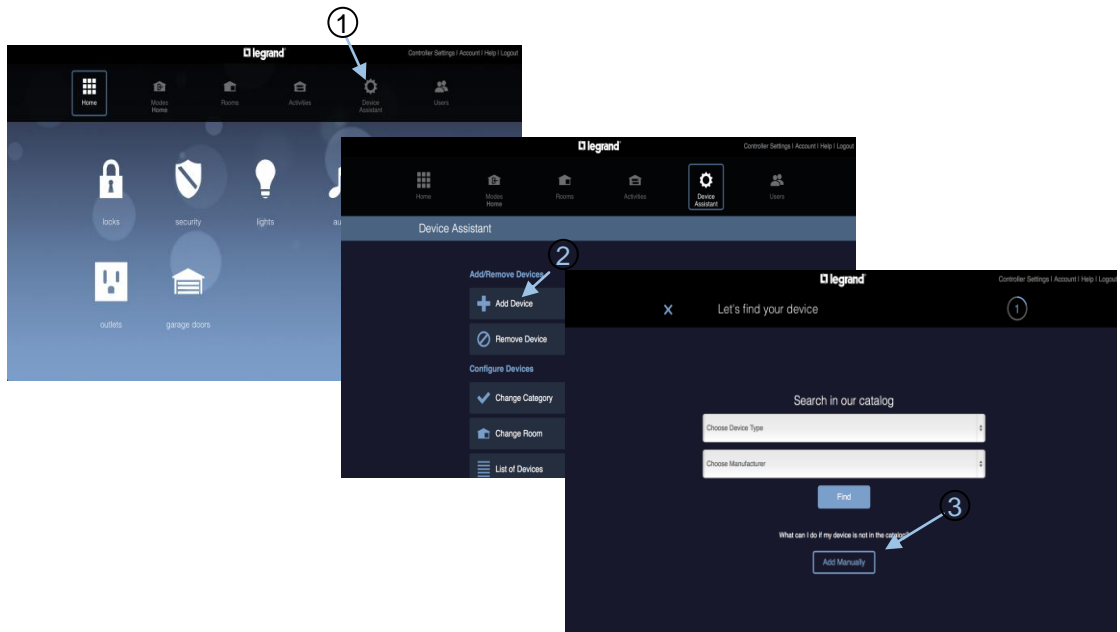

Click on “Legrand Digital Audio Device Adapter” and then click “Add”.

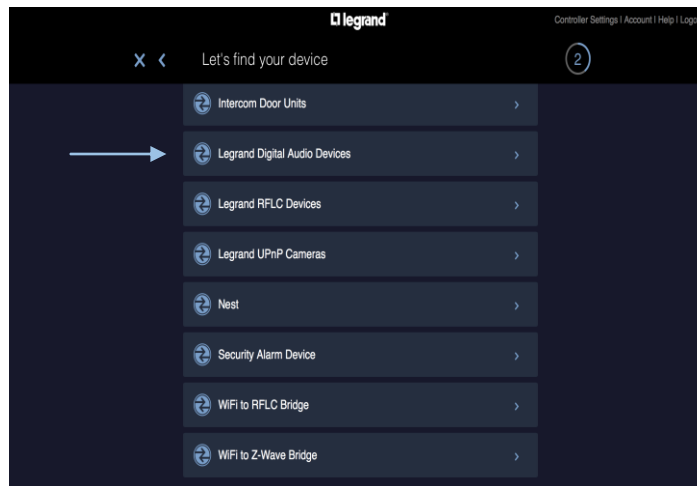

The Legrand Digital Audio system will then be discovered and the zones will be added to the “Device List”.

NOTE: Digital Audio Zone names should be setup through the Digital Audio App first. The zone names will then transfer to the Intuity System when above steps are performed. Should you need to change the zone names in the Digital Audio App after adding them to Intuity, you will need to remove the “Legrand Digital Audio Device Adapter” from the list of devices and then follow the outlined steps above to add the system to Intuity again.

7.4 Adding Intercom System Door Units

To add the Legrand Intercom System Door Units (up to 4), simply ring each door bell, and they will be discovered and added to the “Device List”. Configure the system by naming the door units and assigning them to rooms.

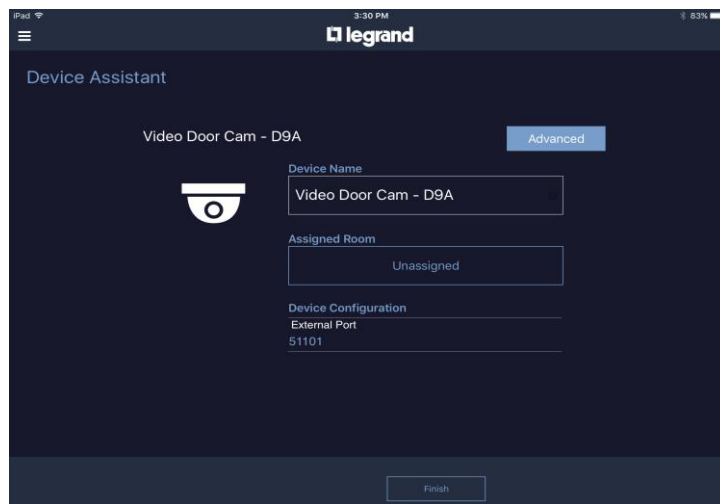
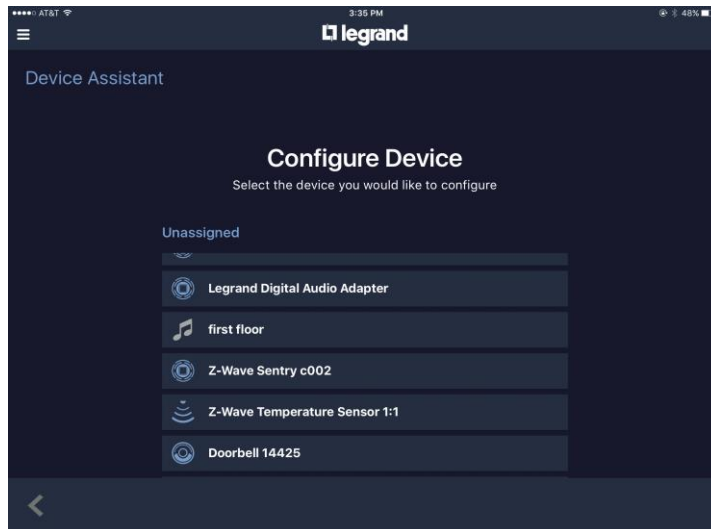

8.0 Creating Activities

Creating Activities allows Intuity to “automate” certain functions like controlling audio zones, controlling lights, locking/unlocking doors and changing thermostat temps. All based upon triggering events such as doorbell rings, door unlocks, or window openings, etc.

The following activity example is based around the triggering event of a doorbell ring. For additional information on activities and many more examples, please refer to the Legrand Intuity User Guide (P/N [1308241](#)).

8.1 Creating a Doorbell Notification Activity

To create an automatic activity based upon the trigger of a doorbell ringing, open the home page of the browser and click on “Activities”.

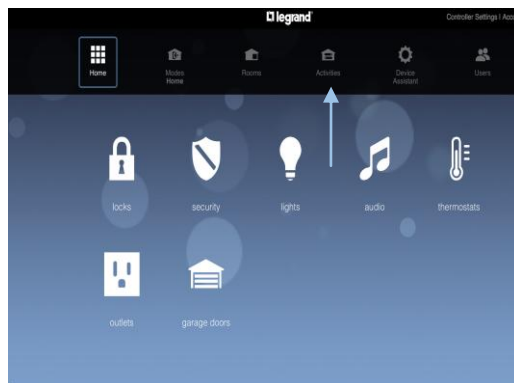

Then click “+” and give the activity a name.

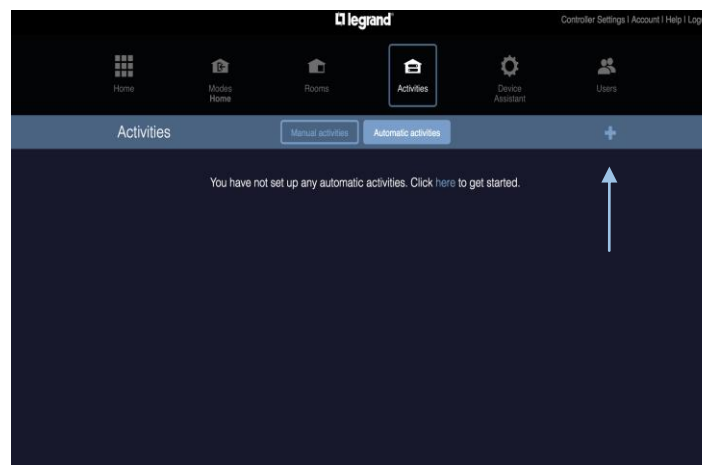

Next select how the activity gets started. In this case we want “I want one of my devices to start the activity”. Click “Next”. Then select the doorbell and click “Next”.

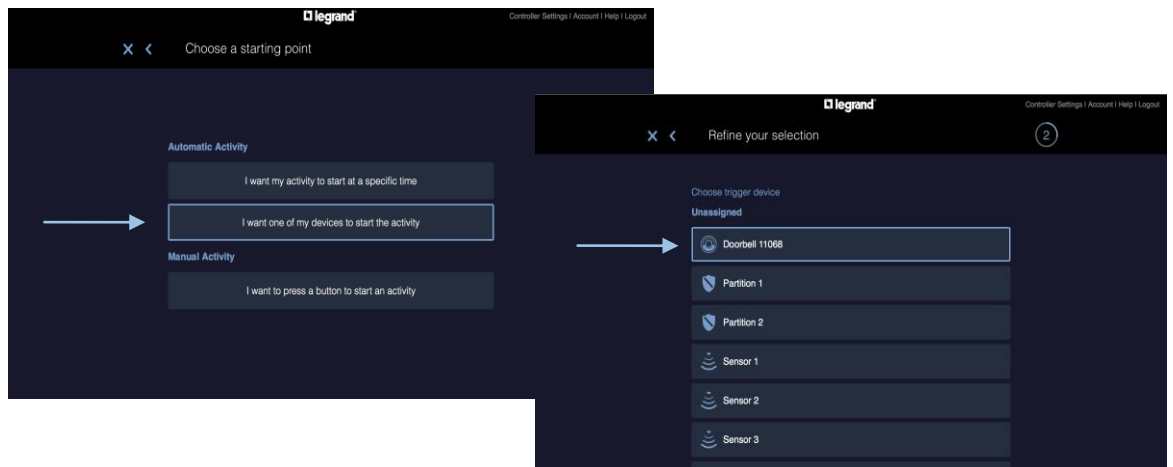

The reason for this activity is “doorbell rings”. Select the days and times (maybe it should happen only while at work for instance) and click “Set”.

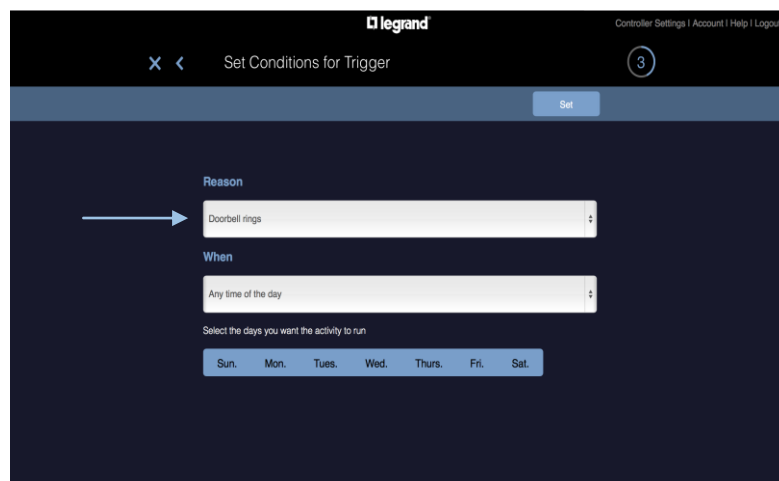

Next select the devices you want to control like turning on the outside light (and maybe the room light for the room the door accesses like the kitchen) then click “Choose”.

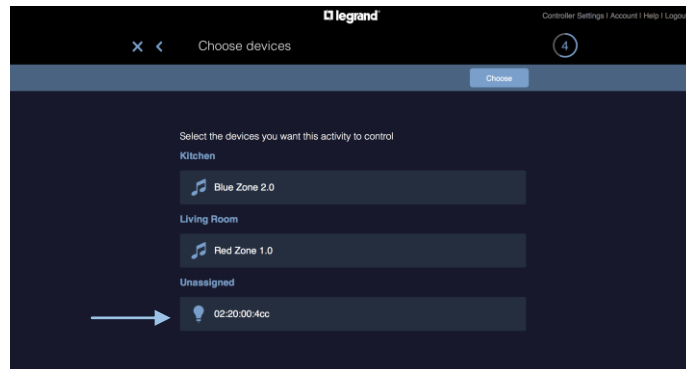

Next set the light that will be part of the activity to “On” (if this is a dimmer, set the light level desired). Then click “Set”.

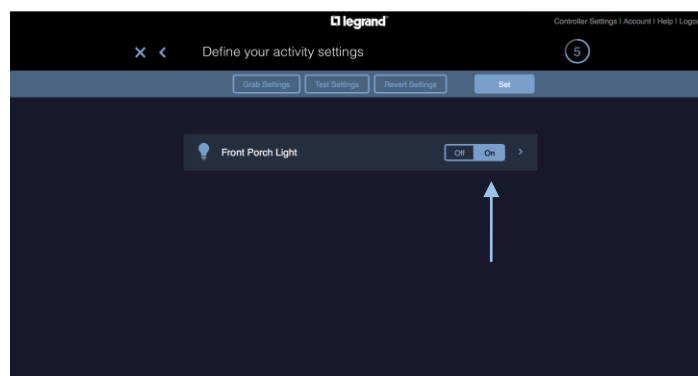

Next select which of the four possible Modes this activity should work under. They are all selected by default. This activity might not be useful when at home, or asleep, but that is really up to the customer to decide. Click “Choose” to continue.

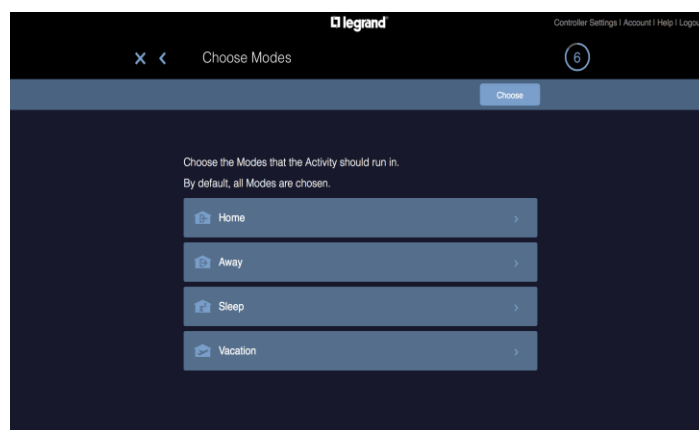

Next, the notification setup screen will appear. Here you can select whether mobile push notifications are enabled when the door bell rings and what message is received when that action occurs (“Someone at the front door” for example). Select “Push” notifications and choose what action occurs when someone opens notification on their mobile device (such as viewing the door camera). Select “Finish” when done.

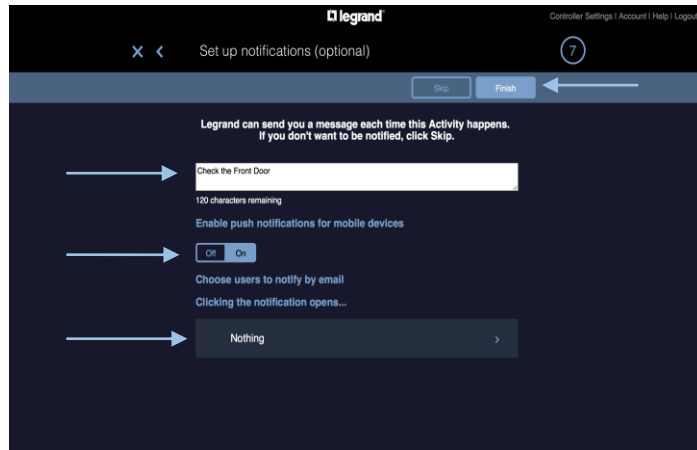

Appendix A: FAQ

1. How do I return a Bridge to Factory Default?

Press the “Connect” button 10 times. LED’s on the Bridge should begin flashing then change to Factory Default after 10 seconds.

Factory Default is signified by the Top LED appearing solid, middle LED blinking slowly, and bottom LED off.

If the Bridge does not appear to Factory Default, press the recessed “Reset” button on the front of the Bridge for 2 seconds with a paper clip. If the Bridge still does not appear to Factory Default, repeat steps above or call Legrand Technical Support for further assistance.

NOTE: Pressing the recessed Reset button on the front of the Bridge for 2 seconds with a paper clip power cycles the Bridge.



2. Can I commission the Intuity system from a tablet?

Yes, however, the recommended method is to use a Notebook, Tablet, or Laptop with a Chrome/Safari browser.

3. Why can't I see cameras from the browser?

This capability will be available in a future software update. Today Cameras can be named and assigned to a room from the browser. We recommend launching a separate browser during commissioning to view the Cameras if needed. Cameras can also be viewed from the Intuity App.

4. How does the user view their cameras?

Homeowners will view their Cameras from the Intuity App. For remote viewing, refer to Section 7.2.1 of this manual.

5. How do I change a Security Subsystem Zone Name?

Zones should be named in the Security subsystem prior to commissioning Intuity. Security Zone names are downloaded from the Alarm Panel to the Intuity system during commissioning of the Security subsystem. Refer to the Security system installer for assistance.

6. How do I set up Quick Arm?

Quick Arm must first be setup on the Security subsystem by the security installer. Refer to Section 7.1 of this manual for changing Quick Arm settings inside of Intuity.

7. How do I change an Audio Zone name?

The Legrand Digital Audio subsystem should be commissioned and Zones named before commissioning the Intuity system. Audio Zone names are downloaded from the Legrand Digital Audio subsystem to Intuity during audio commissioning. To name audio Zones refer to Legrand Digital Audio user documentation.

8. How do I Reset the Intuity Controller back to factory default?

We recommend Intuity system installers only perform a factory reset when instructed by Legrand Technical Support.

9. How do I Reboot the Intuity Controller?

We recommend contacting Legrand Technical Support if it is felt a reboot should be performed. The system can be rebooted via a power cycle or via the web browser (refer to Appendix B4/7). Please allow at least 2 minutes after a system reboot is performed for the system to load settings.

10. How do I see my list of Authorized Mobile Devices?

Refer to the Appendix B3 of this manual.

11. How do I change the Account name/password?

The installer should use the homeowner's email address and a generic password ("PASSWORD") when commissioning the system. The homeowner can then change to their preferred password via logging into their system via the web browser (<https://intuity.legrand.us>). Refer to Appendix B1/2.

12. How do I un-register the Controller (i.e. Homeowner is moving)?

This can be done from the web browser (<https://intuity.legrand.us>). Refer to Appendix B4.

13. How do I change the system Date/Time/Zip code?

This can be performed from the web browser (<https://intuity.legrand.us>). Refer to Appendix B5.

14. How do I add/remove a User?

Users are added to the system in order to receive email notifications of system activities (i.e. "Someone unlocked the Front Door"). A User consists of their name and email address. Users can be added/removed via both the Intuity App and the web browser (<https://intuity.legrand.us>). Refer to Section 5.2 of this manual.

15. How do I setup an Activity for the User?

Refer to Section 8.1 of this manual for an example of creating an activity.

Appendix B: Advanced System Commissioning

The Intuity System is designed to be controlled from “smart” devices such as the iPad Mini based Command Center or a mobile iPhone, Android device, etc. through the use of the Legrand Intuity App. However, there are functions that require a browser-based control method, such as changing the Date and Time, or changing the User ID or Password, or Re-naming an Intuity Account. All of these and other “Advanced System Commissioning” procedures are discussed below.

1. **Re-name an Intuity Account** – Click the down arrow to the right of Account Settings under Account Overview.

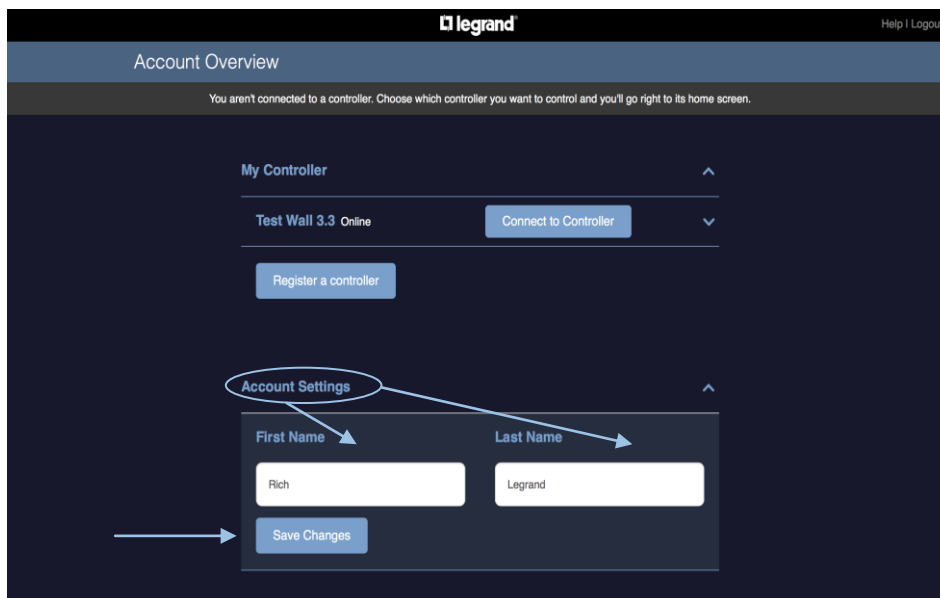

NOTE: This does not change the email/username for account login. This only changes the Homeowner name.

2. **Changing a Password** – Click on the down arrow to the right of Password Settings. You must enter the current password before making a password change in the system.



3. **List of Authorized Mobile Devices** – For a list of devices that have authorization to access the system, simply click on the down arrow – to the right of Authorized Mobile Devices. Notice that any device on the list can have its authorization revoked by pressing the “Disconnect” button.

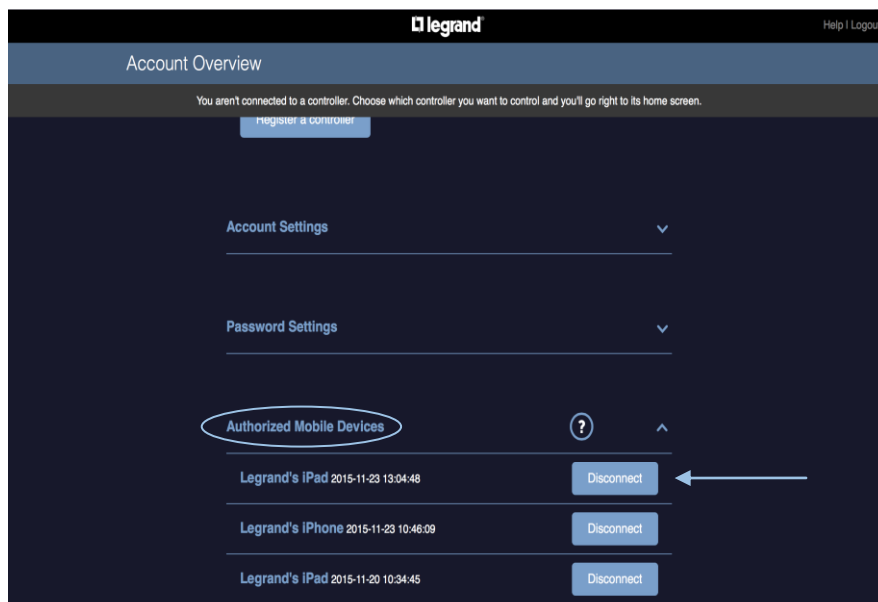

4. **Un-register a Controller** - To un-register a controller (for example, the homeowner is selling their home, or needs to change the email address used on the account) click on the down arrow to the right of the “Connect to Controller” button.

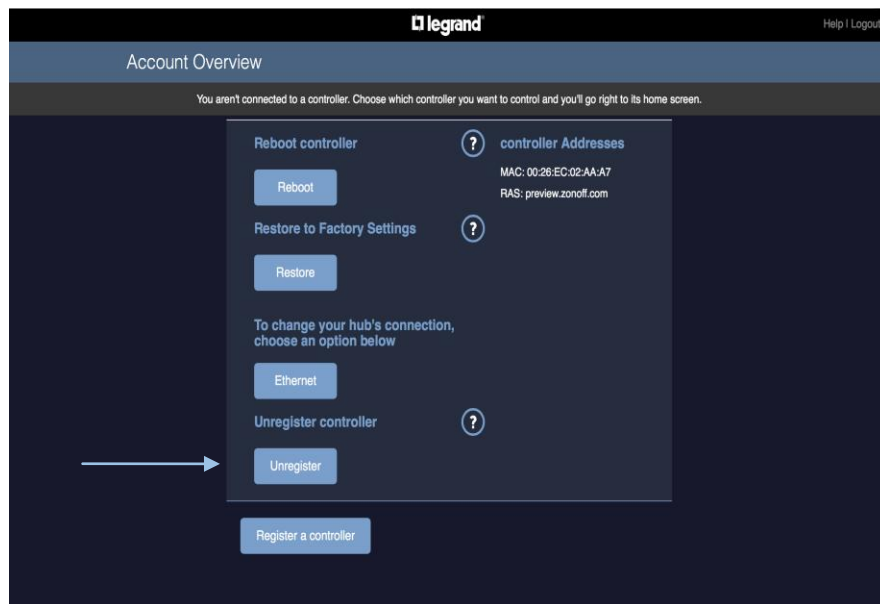

5. **To Change Controller Name/Zip code/Time Zone** – To change the primary credentials of the controller, such as its Name, its Location and even Time Zone, click on “Controller Settings” at the top right of the “Home Screen”.

NOTE: Only US Time Zones (zip codes) are currently supported.

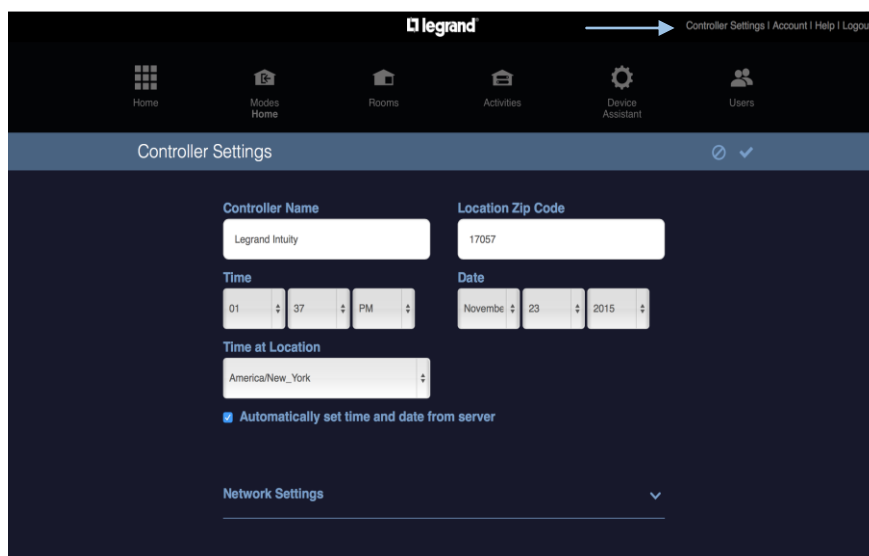

6. **To View Network Parameters** – To view the network parameters associated with the Intuity System, click on the down arrow to the right of Network Settings.

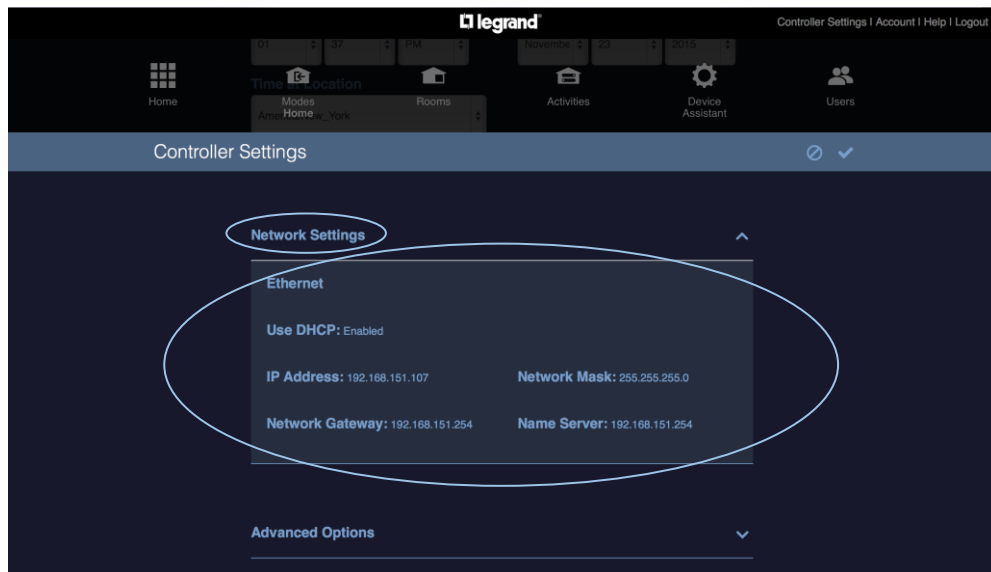

7. **To Remove a Device from the Intuity System** – Select “Device Assistant”, “Remove Device” and you will see a List of all Device Adapters.

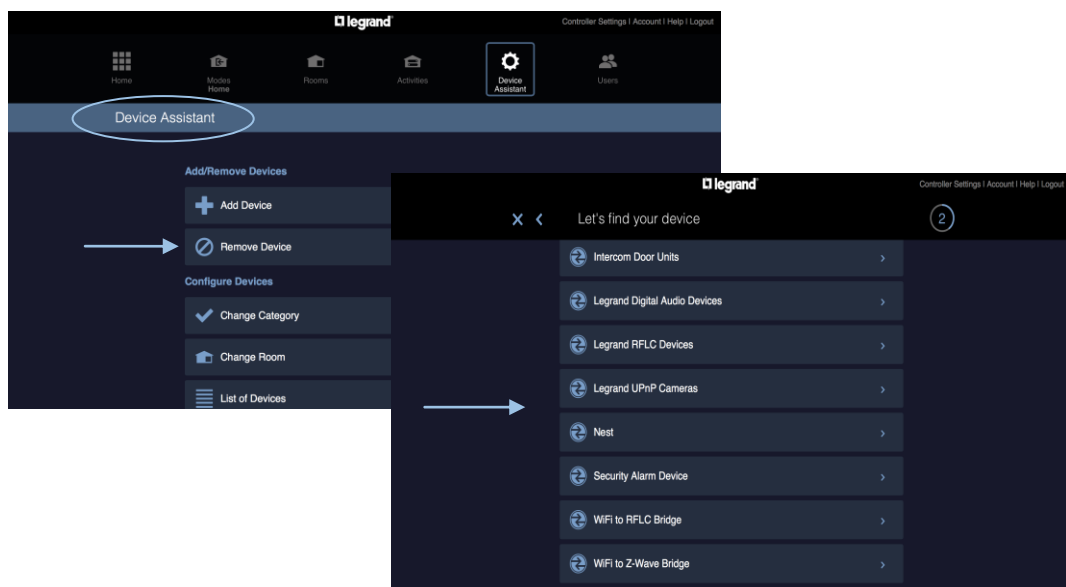

Select the type (Protocol Adapter) of the device you wish to remove and select the actual device to remove on the next screen (we're using the Honeywell WiFi thermostat as an example).

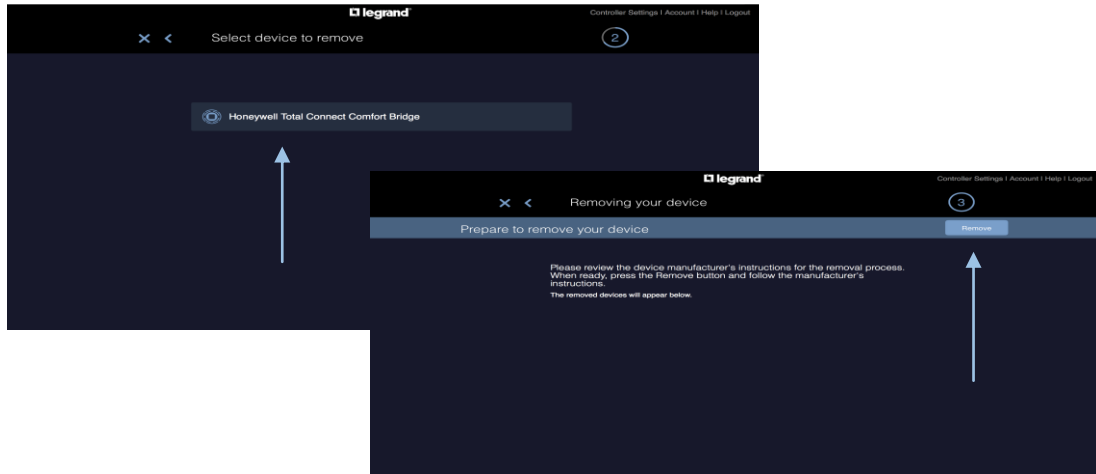

When you select the device, you will see a screen reminding you to review the manufacturer's instructions for device removal. Then press the "Remove" button.

NOTE: Once you select the Category list, you will be presented with a list all devices currently installed on the system pertaining to that Category. At the top of this list is the Device Adapter (software). If you select and Remove the device adaptor all devices under the list will be removed from the system, along with the Adapter software!!

There are two methods to reinstall an Adapter that has been removed,

- 1) Power cycle the system, then wait 2-5 minutes for the adapter to download again.
- 2) From the main menu select "Device Assistant", "Add Device" and "Manual Addition". Then pick the device adapter (without having to power cycle). Using this method will require you to perform this step two times in order to discover devices (once to install the adapter and again to install the devices).

NOTE: Some devices can only be removed by removing the Device Adapter. These devices include:

1. Security System Zones
2. Partitions
3. Audio Zones
4. Thermostat Sensors

NOTE: To remove Z-Wave devices, the pairing button on the device itself must be pressed after the "Remove Device" selection has been made in the WiFi to Z-Wave adapter.

8. **Controlling the Intuity System from a web browser –Sign in and control the Intuity system from a Chrome or Safari web browser at <https://intuity.legrand.us>**

From the account page, click on the “Connect to Controller” button, and a new “Home” screen appears, that is similar to the mobile App “Home” screen.

Notice there is no camera button. Cameras are meant to be viewed via the App only for privacy.

NOTE: IP Cameras can always be viewed by opening a second browser page and directly entering the Cameras IP address and Port (i.e. 192.168.40.103:8090)

Notice at the top right of the screen, there is a Controller Settings button, and an Account button.

