

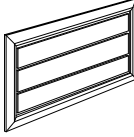

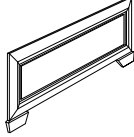

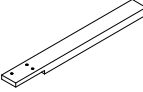
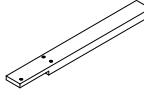
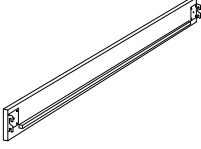
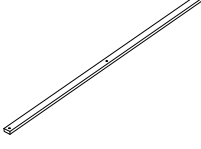
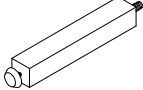
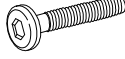

ASSEMBLY INSTRUCTION

BED

| | | | |
|---|--|--|--|
| A Headboard  1 pc | B Footboard  1 pc | C Headboard Leg (L)  1 pc | D Headboard Leg (R)  1 pc |
| E Side Rail  2 pcs | F Bed Slat  4 pcs | G Bed Slat Support  4 pcs | H JCBC Bolt M6 x 30mm  6 pcs |
| I Spring Washer Ø1/4"  6 pcs | J Flat Washer Ø1/4" x 13mm  6 pcs | K CSK Screw M4 x 32mm  8 pcs | L Allen Key M4 x 65mm  1 pc |
| M Allen Key M5 x 65mm  1 pc | | | |

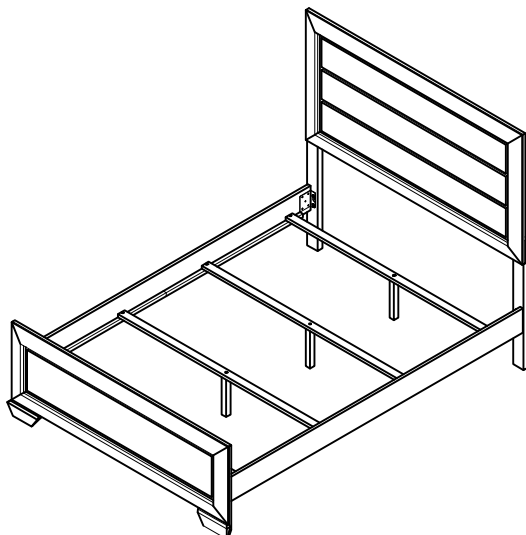

This page lists all the contents included in the box. Please take the time to identify the hardware as well as the individual components to this product. As you unpack and prepare for assembly, place the contents on a carpeted or padded area to protect them from damage.

IMPORTANT NOTE :

1. Do not tighten all screws / bolts until all completely assembled.
2. Keep all hardware parts out reach of children.

- 1** Attach and tighten Headboard Leg (C) & (D) to Headboard (A). Fix Headboard (A) & Headboard Leg (C) & (D) using JCBC Bolt (H), Spring Washer (I), Flat Washer (J) using Allen Key (L).

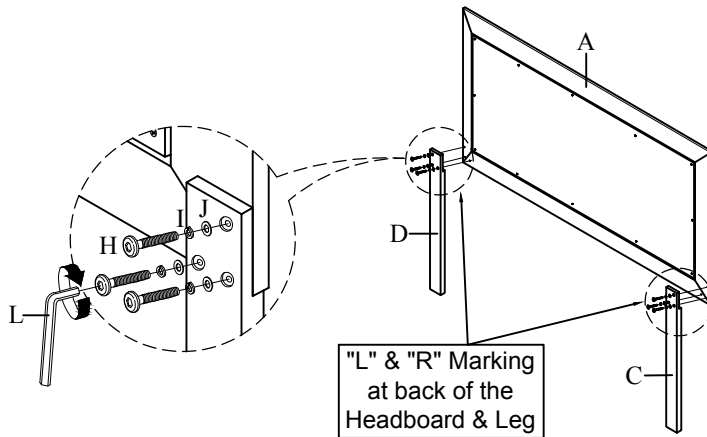

- 2** STEP 2.1: Attach Side Rail (E) to Headboard Leg (C) and (D).
STEP 2.2: Tighten screw on Headboard Leg (C) and (D) by using Allen Key (M) and repeat the same step on Footboard (B).

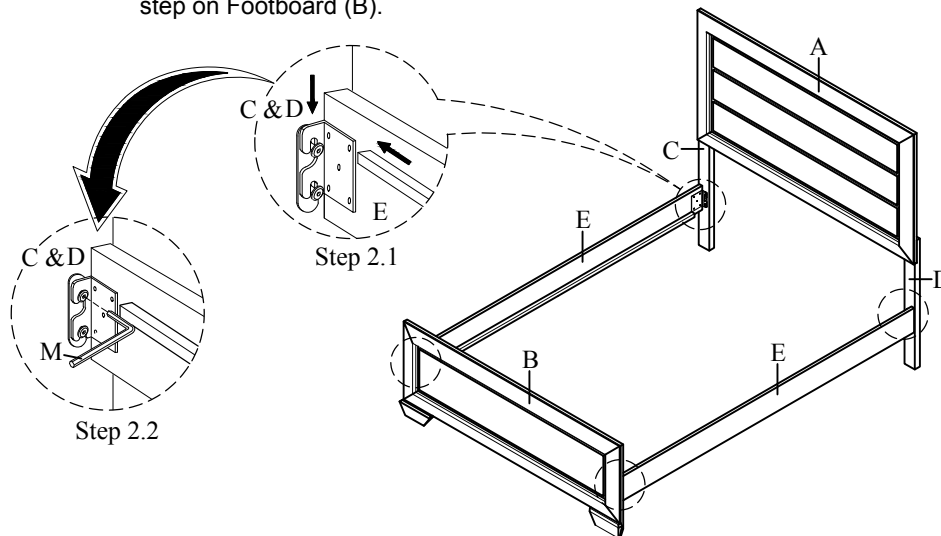

- 3** STEP 3.1: Attach Bed Slat (F) to Bed Slat Support (G). Adjust adjuster until stable.
STEP 3.2: Adjust Bed Slat Support (G) according to the ground level.
STEP 3.3: Attach Bed Slat (F) and tighten to Side Rail (E) with CSK Screw (K).

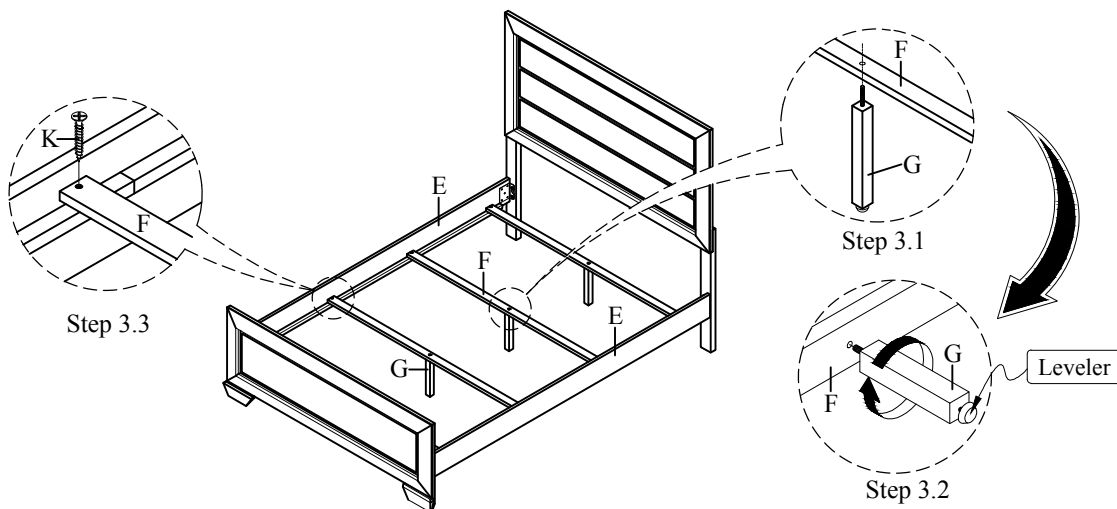

CLEANING & CARE

Treat surface with care. Surface is resistant to scratches but is not scratch resistant. Clean surfaces with a dry or damp soft cloth. Do not use abrasive cleaners. Hardware may loosen over time. Periodically check that all connections are tight.