

Liner Specification

* 35 F-217 WCS

Dimensions in Order of Composition (Mils, Nominal):

Solid PE	2.5
Foamed LDPE Core	30
Solid PE	2.5

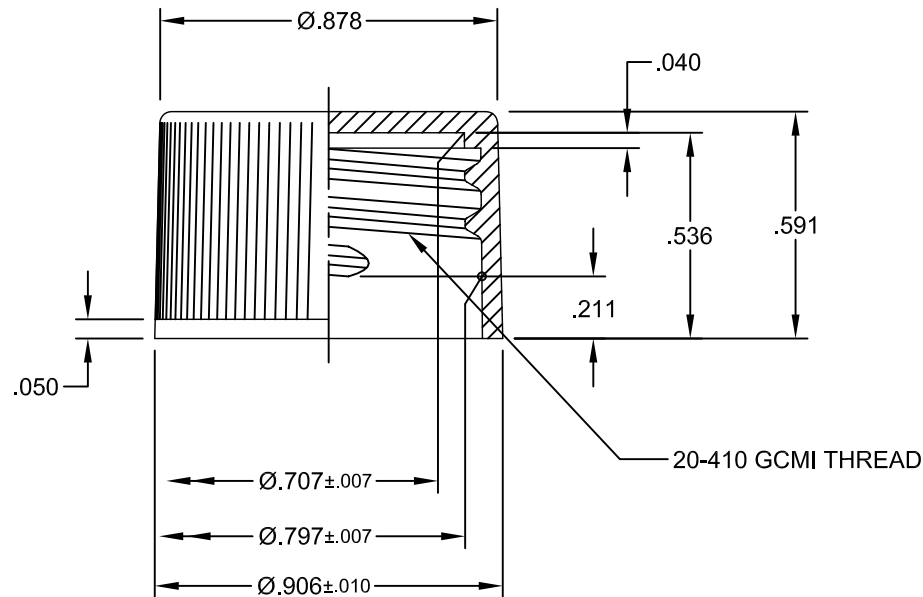

DISCLAIMER

THIS INFORMATION IS PROVIDED AS A GENERAL GUIDE, INCLUDING DIMENSIONS. IT IS THE CUSTOMER'S RESPONSIBILITIES TO SELECT THE PROPER CONTAINER FOR PRODUCT AND APPLICATION COMPATIBILITY.

DISTRIBUTED BY:



REF NO.:

DWG30429

DESCRIPTION:

204-10 Ribbed Plastic Screw Cap with F217 Liner

F-217®

- F-217® is a coextruded primary liner consisting of a foamed Low-Density Polyethylene (LDPE) core with solid Low-Density Polyethylene (LDPE) layers on both sides.
- Does not promote microbial growth.

Typical Product Attributes			
Construction			
Solid LDPE Foamed LDPE Solid LDPE		SI (µm) Total Thickness 508 – 3175	US (mils) Total Thickness 20 - 125
Properties			
Color Opacity Density 508 – 762 µm 20 – 30 mil 889 – 3175 µm 35 – 125 mil Thickness Tolerance 508 – 1524 µm 20 – 60 mil 1650 – 2290 µm 65 – 90 mil 2410 – 3180 µm 95 – 125 mil Available Widths 508 – 1520 µm 20 – 60 mil 1650 – 3180 µm 65 – 125 mil Width Tolerance		White or as specified Opaque 480 ± 30 kg/m ³ 400 ± 30 kg/m ³ ± 127 µm ± 178 µm ± 254 µm 25 – 1016 mm 25 – 228 mm ± 1,6 mm	White or as specified Opaque 30 ± 2 lb./ft ³ 25 ± 2 lb./ft ³ ± 5 mil ± 7 mil ± 10 mil 1 – 40 in 1 – 9 in ± 0.0625 in
Regulatory Compliance			
FDA Compliance Drug Master File (DMF) Other Compliances Safety Data Sheet (SDS) Statement	21 CFR 177.1520 Olefin polymers. 21 CFR 177.1210 Closures with sealing gaskets for food containers. 002434 USFDA Food Allergen Guidelines California Proposition 65 Labeling Requirements Limitations of Heavy Metals in Packaging per CONEG & EU 94/62/EC, Article 11 Meets the compositional requirements of Regulation (EU) 10/2011 on plastic materials and articles intended to come into contact with food Safety Data Sheets (SDS) are not required for articles as defined in 29 CFR 1910.1200, the OSHA Hazard Communication Standard (HazCom). This product is an article as defined by HazCom and is not considered to be, or to contain, a hazardous chemical based on evaluations made by our company.		
Please note that construction does not reflect adhesive or resin bonding layers, if present.			
	VERSION	9	DATE 2021-07-26

<p align="center">DISCLAIMER</p> <p>THIS INFORMATION IS PROVIDED AS A GENERAL GUIDE, INCLUDING DIMENSIONS. IT IS THE CUSTOMER'S RESPONSIBILITIES TO SELECT THE PROPER CONTAINER FOR PRODUCT AND APPLICATION COMPATIBILITY.</p>	DISTRIBUTED BY:	REF NO.:
	DESCRIPTION: 204-10 Ribbed Plastic Screw Cap with F217 Liner	DWG30429