

Product Specifications

5.3-Gallon EZ STOR® Hinged Cover

Multiple Uses

Dry Products

Product Codes

Cover: **ESDH / ESDR**

Description: Dry seal, tamper-evident, hinged EZ open & close cover

Features

Tare weights:

Cover: .39 lbs. / .18 kgs.

Note: *Ratings will be reduced with uneven load distribution.

Colors

Standard: White, Black, Natural and Clear

Custom: Available at manufacturer's discretion

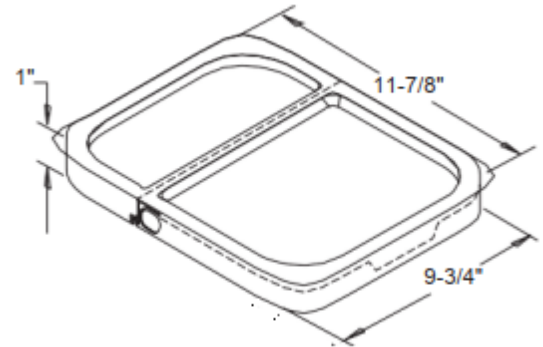

Shipping Data

Qty. per pallet:

Gross Weight (lbs./kgs)*:

Den. (lbs./C.F./kgs./m3):

Length (in./cm.):

Width (in./cm.):

Height (in./cm.):

Covers

1,440 (30 boxes of 48)

561.6/259.2

6.1/99.3

48/121.9

40/101.6

83/210.8

Estimated truckload quantity of 6,336 bodies and covers**

Notes: *Weight does not include pallet / packaging

**Truckload quantity based on 53' trailer

Materials

FDA approved materials

Resin:

Cover: Polypropylene (PP)

DISTRIBUTED BY:



REF NO.:

DWG30568

DESCRIPTION: HDPE EZ Stor Hinged Cover for 5.3 Gallon Pails

DISCLAIMER

THIS INFORMATION IS PROVIDED AS A GENERAL GUIDE, INCLUDING DIMENSIONS. IT IS THE CUSTOMER'S RESPONSIBILITIES TO SELECT THE PROPER CONTAINER FOR PRODUCT AND APPLICATION COMPATIBILITY.