

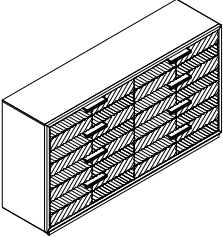

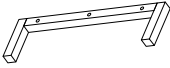
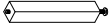

ASSEMBLY INSTRUCTION

DRESSER WITH 3 SETS OF MODULAR DRAWER DIVIDERS

A Dresser  1pc	B Metal Leg  2pcs	C Support Leg  1pc	D Bolt Ø1/4" x 45mm  6pcs
E Spring Washer Ø1/4" x 12mm  6pcs	F Flat Washer Ø1/4" x 16mm  6pcs	G Allen Key M4  1pc	H Tipping Restraint Kit  1set

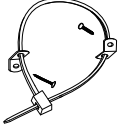
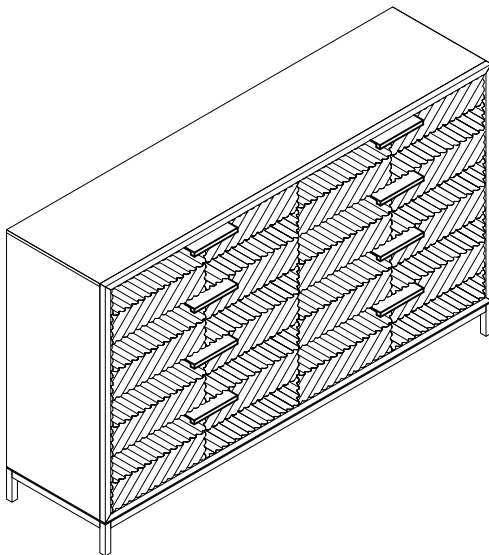

This page lists all the contents included in the box. Please take the time to identify the hardware as well as the individual components to this product. As you unpack and prepare for assembly, place the contents on a carpeted or padded area to protect them from damage.

IMPORTANT NOTE

1. Do not tighten all screws / bolts until all completely assembled.
2. Keep all hardware parts out of reach of children.

- 1** Attach Metal Leg (B) on the bottom of Dresser (A) by inserting Bolt (D), Spring Washer (E) and Flat Washer (F) and tighten with Allen Key (G). Then attach Support Leg (C) under the bottom of Dresser (A).

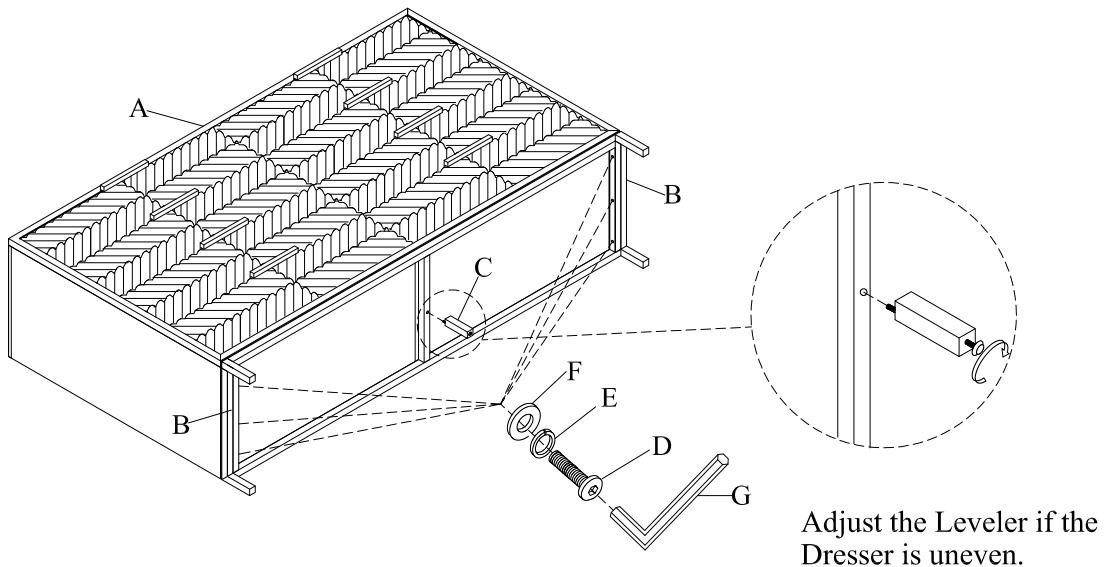

- 2** Staple the Tipping Restraint Kit (H) at the back of the Dresser (A).

Attach Tipping Restraint Kit (H) to wall.

1. Drill holes at wall and Dresser and insert Brackets into holes.
2. Move assembled unit to wall and screw in Steel Cable using Short Screw with Phillips Head Screwdriver (not provided).
3. Screw in Steel Cable at wall using Long Screw with Phillips Head Screwdriver (not provided).

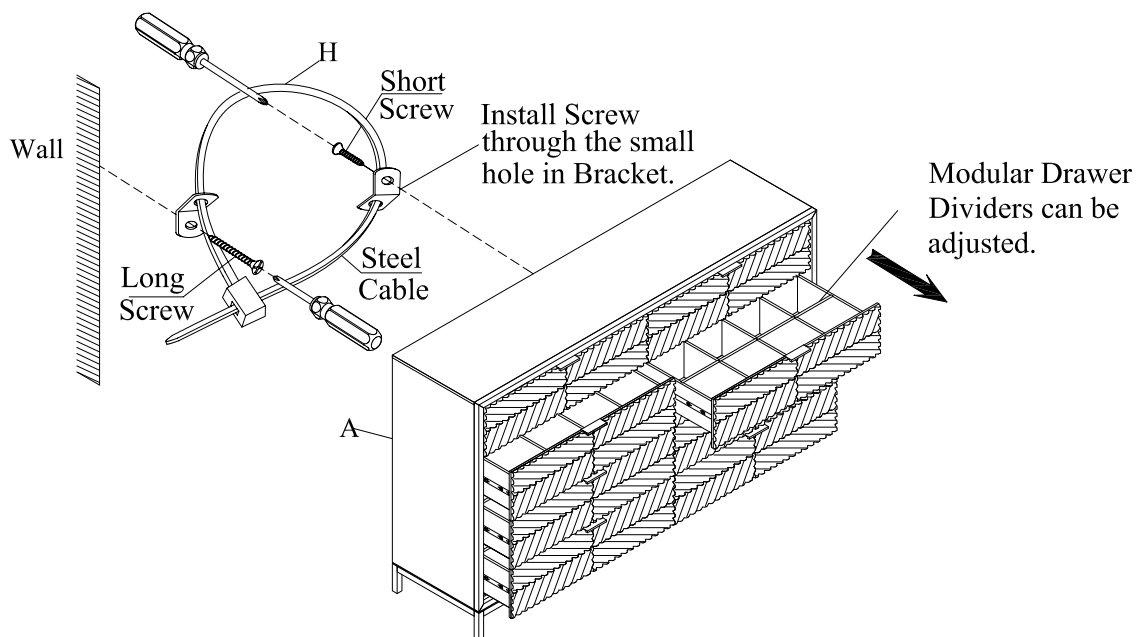

Cleaning & Care:

Treat surface with care. Surface is resistant to scratches but is not scratch resistant. Clean surfaces with a dry or damp soft cloth. Do not use abrasive cleaners. Hardware may loosen over time. Periodically check that all connections are tight.