

Product Uses

Liquid Products

Features

UN Rating: 3H1/Y1.8/100
Nominal capacity: 5.3 USG / 20.0L
Maximum capacity: 5.6 USG / 21.3 L
Tare weights: 2.76 lbs. / 1.25 kgs.

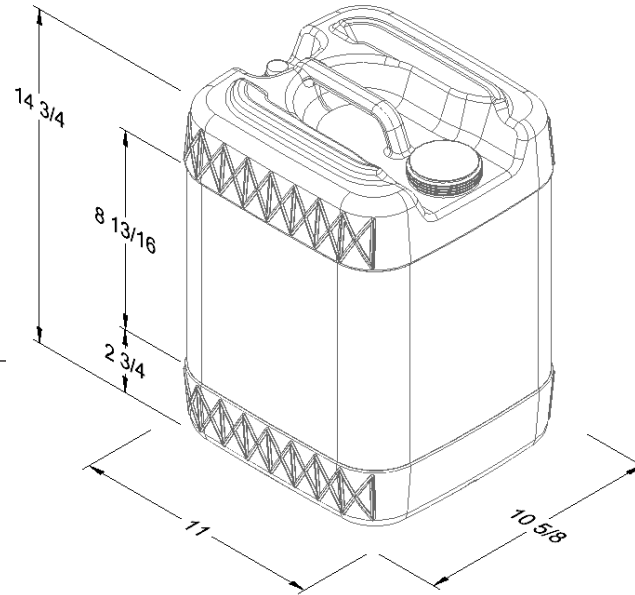

Colors

Standard: White, Black, Natural
Custom: Available at manufacturer's discretion

Decorating Options

Maximum Label Area:
8-1/2" x 8-9/16"
See Salesperson for Options

Shipping Data

Qty. per floor spot:
Gross Weight (lbs./kgs)*:
Length (in./cm.):
Width (in./cm.):
Height (in./cm.):

Containers

56 / 56 = 112
309 / 140
44 / 112
42.5 / 108
101 / 256

Estimated truckload quantity of 3,136 containers**

Notes: *Weight does not include pallet / packaging
**Truckload quantity based on 53' trailer

Materials

FDA approved materials
Resin: High-Density Polyethylene (HDPE)

MSDS Sheets available upon request

Optional Carrying Handle

Integral

DISCLAIMER

THIS INFORMATION IS PROVIDED AS A GENERAL GUIDE, INCLUDING DIMENSIONS. IT IS THE CUSTOMER'S RESPONSIBILITIES TO SELECT THE PROPER CONTAINER FOR PRODUCT AND APPLICATION COMPATIBILITY.

DISTRIBUTED BY:



REF NO.:

DWG30468

DESCRIPTION:

5 Gallon HDPE Tight Head, 70 mm & Closed Vent