

DETAIL A  
SCALE 2 : 1

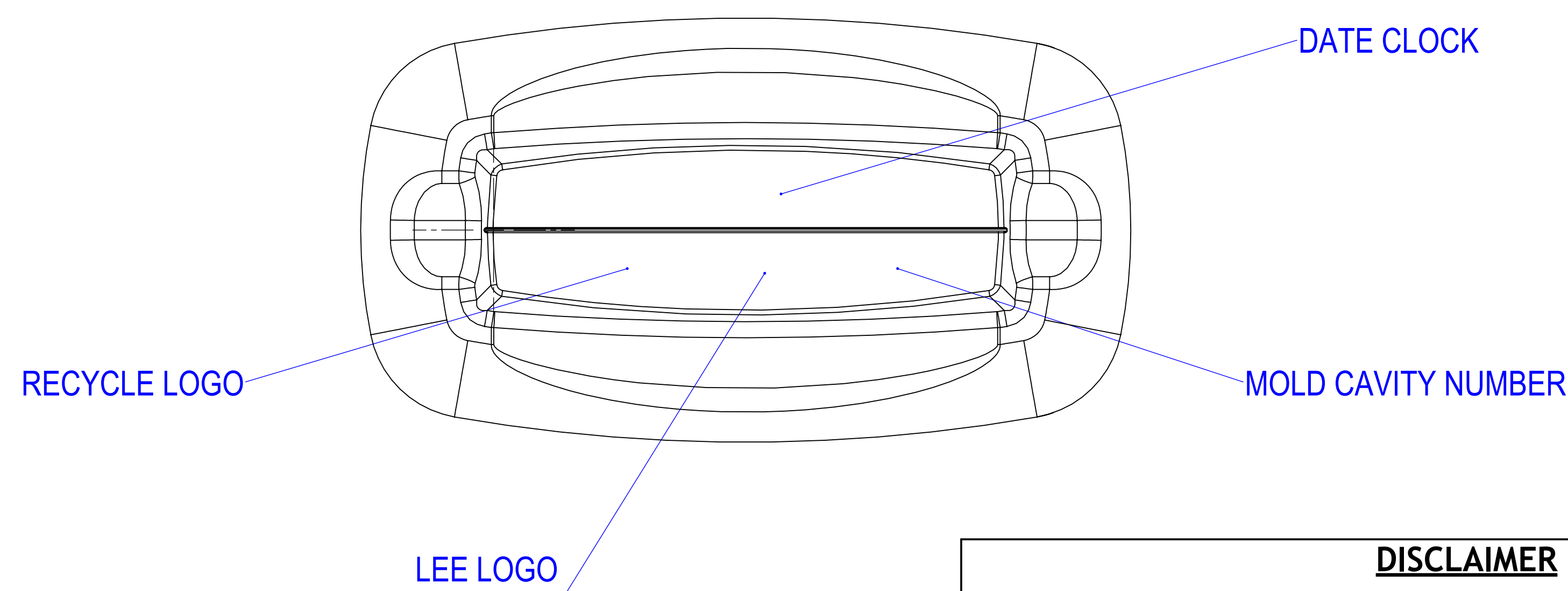
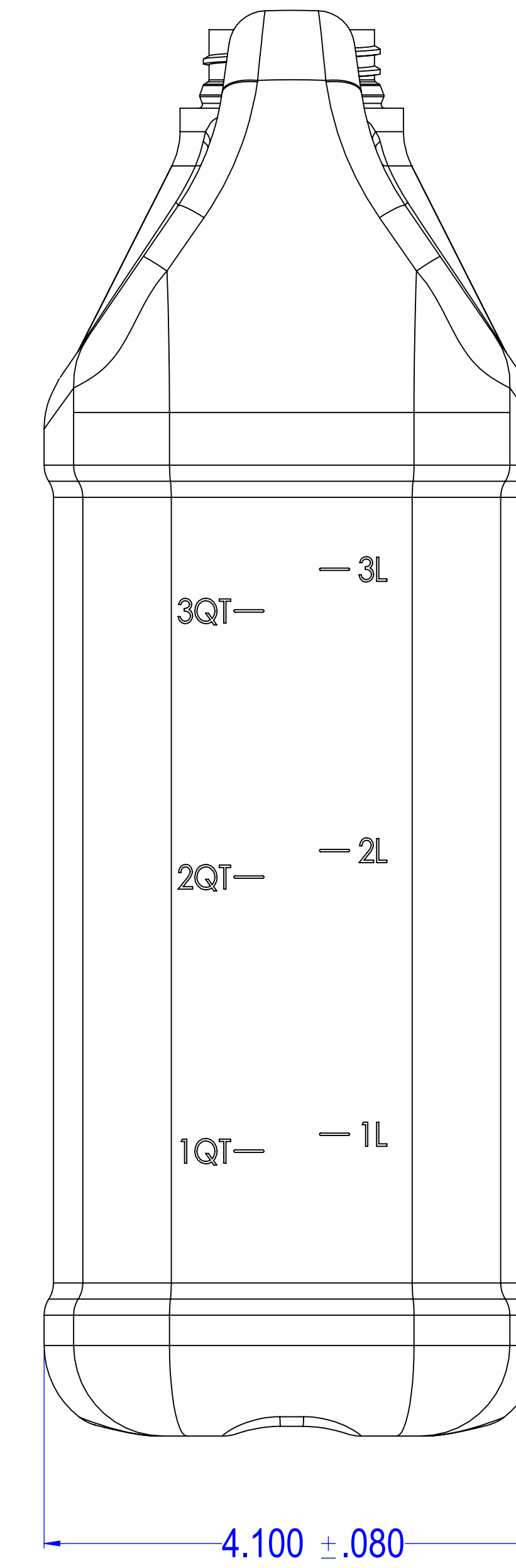
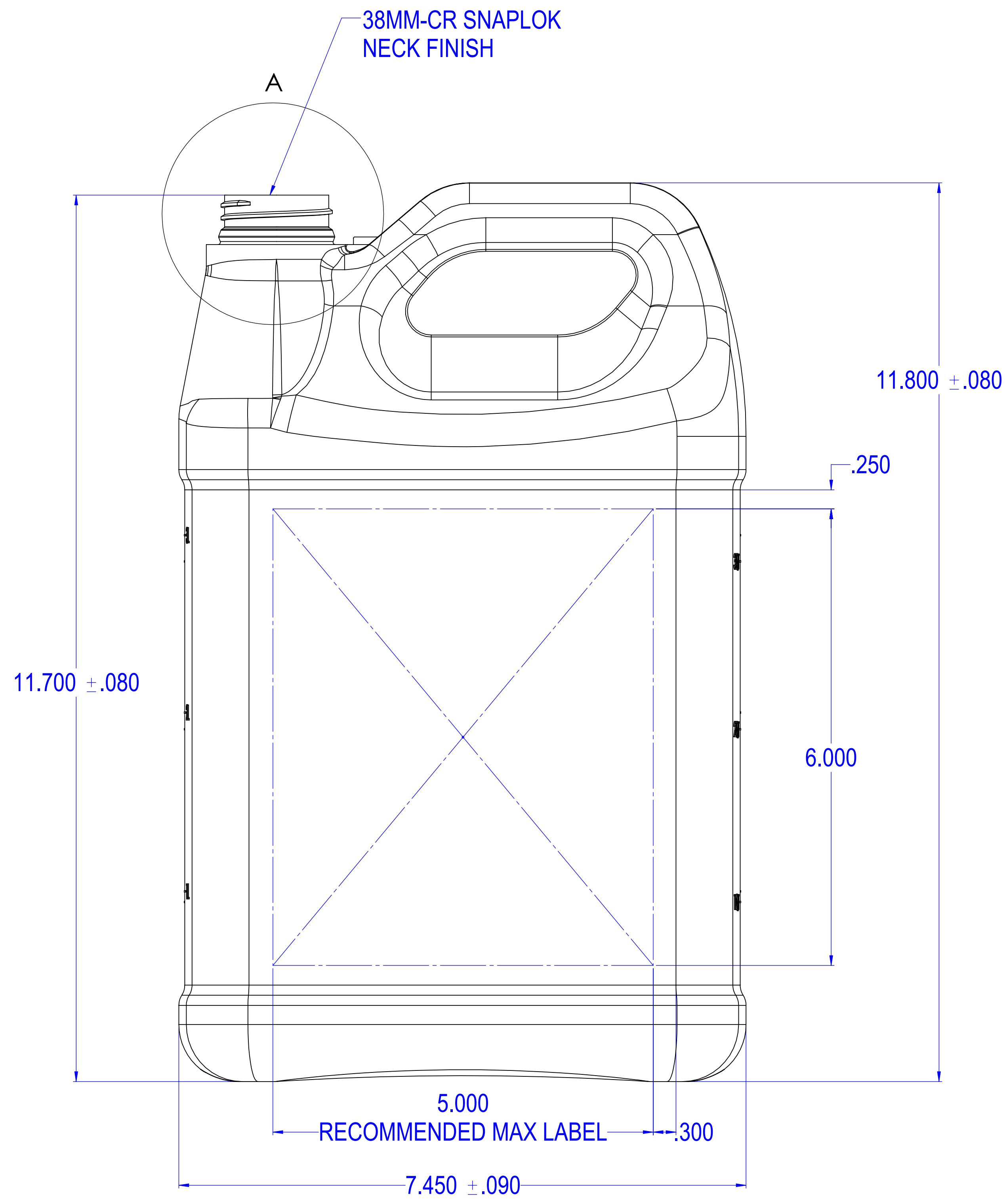
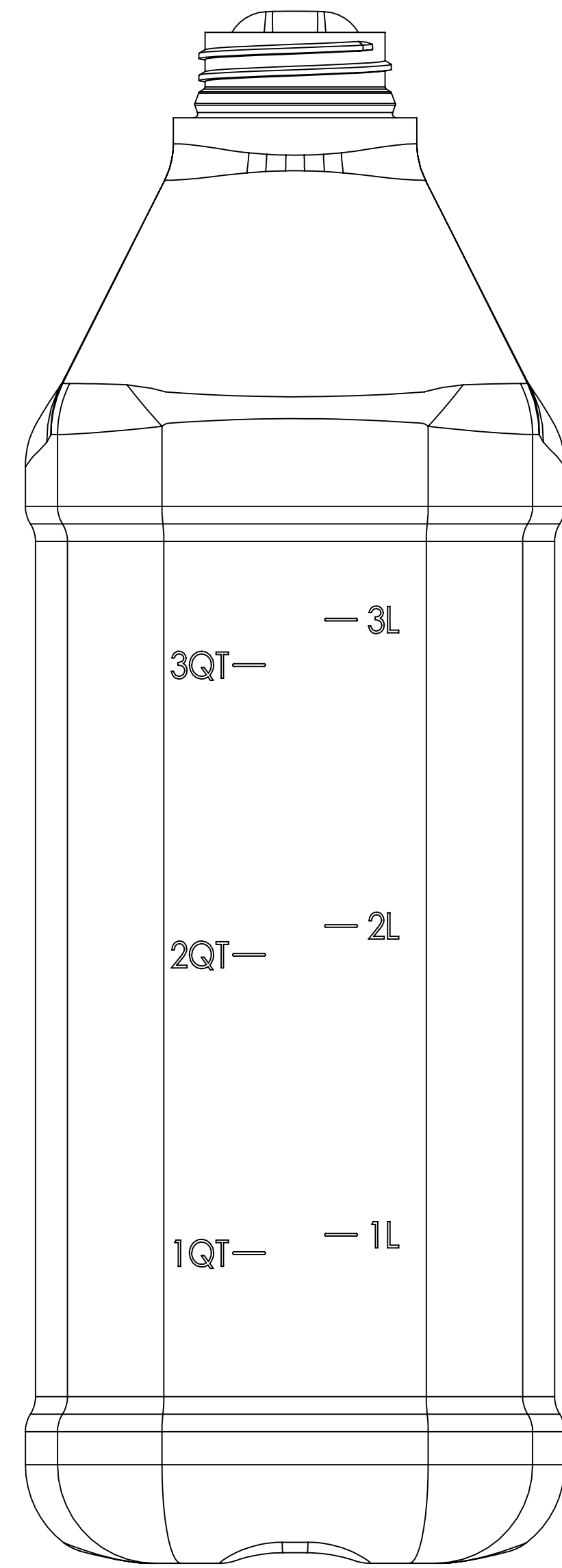
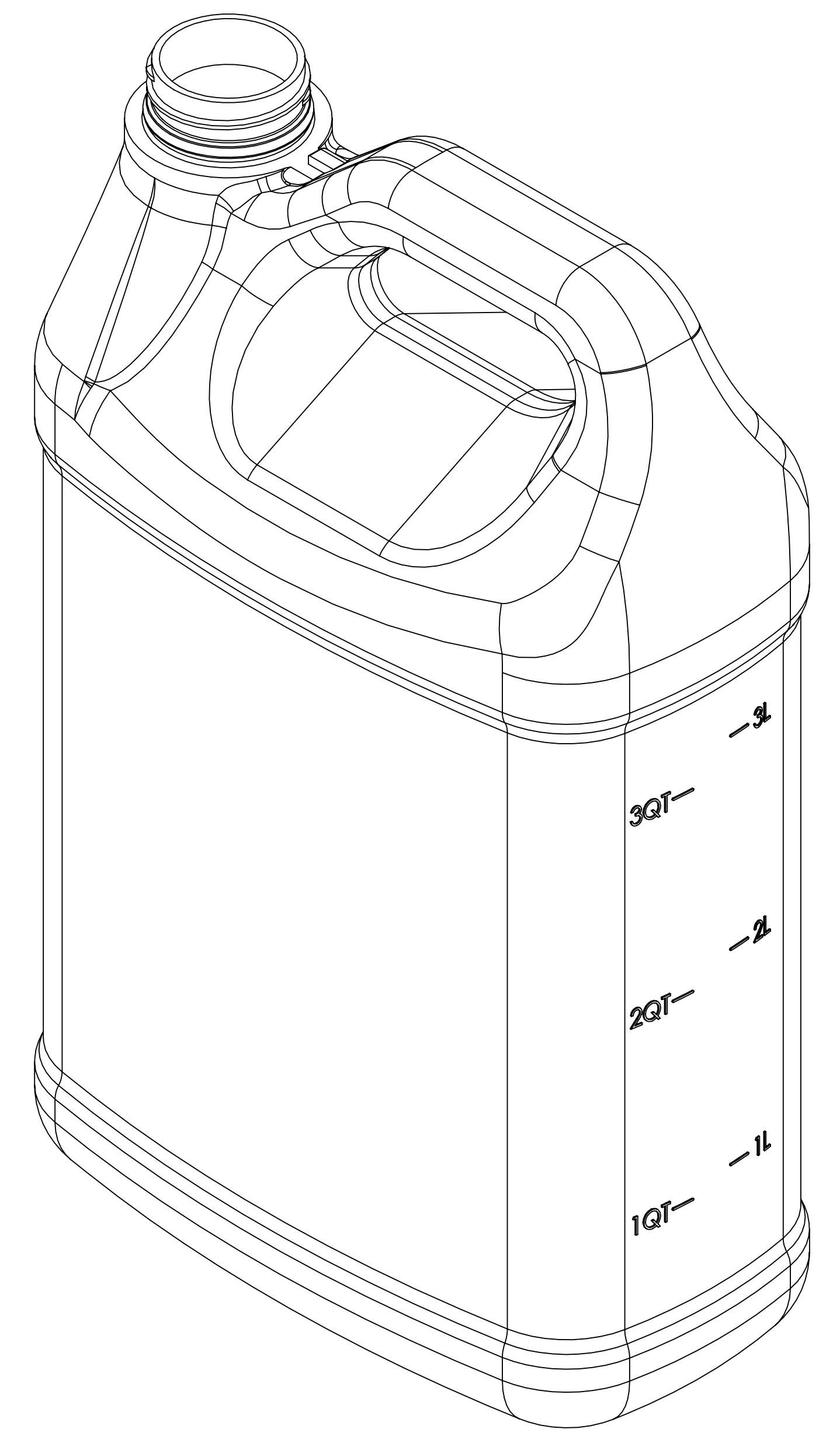
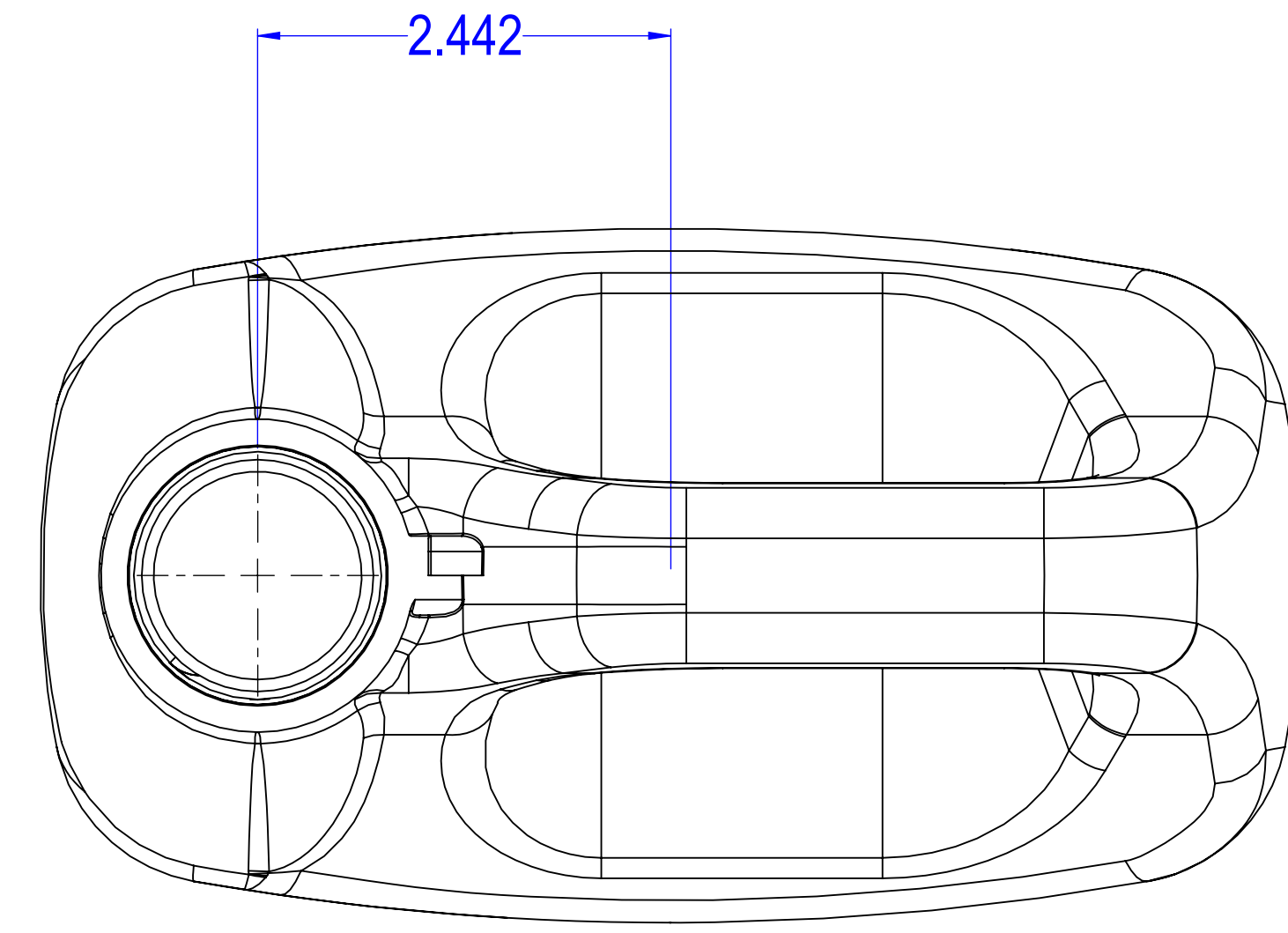

NOTES:  
1. OVERFLOW CAPACITY = 144 FL/OZ (1.12 GAL).

**DISCLAIMER**  
THIS INFORMATION IS PROVIDED AS A GENERAL GUIDE, INCLUDING DIMENSIONS. IT IS THE CUSTOMER'S RESPONSIBILITIES TO SELECT THE PROPER CONTAINER FOR PRODUCT AND APPLICATION COMPATIBILITY.

DISTRIBUTED BY: Pipeline Packaging

REF NO.:  
DWG 31157

DESCRIPTION:  
128 oz HDPE F-Style with View Stripe, 38-400 Rexam