





HEKMAN®

A HOWARD MILLER COMPANY

ASSEMBLY INSTRUCTION FOR 23725 BUFFET

HARDWARE LIST			
NO.	ITEM	DESCRIPTIN	QTY.
1		JCB Bolt M6 X 20 MM	10
2		Flat washer M6X22 MM	10
3		Allen wrench	1
4		Bolt M8X13 MM	4
5		Wrench	1

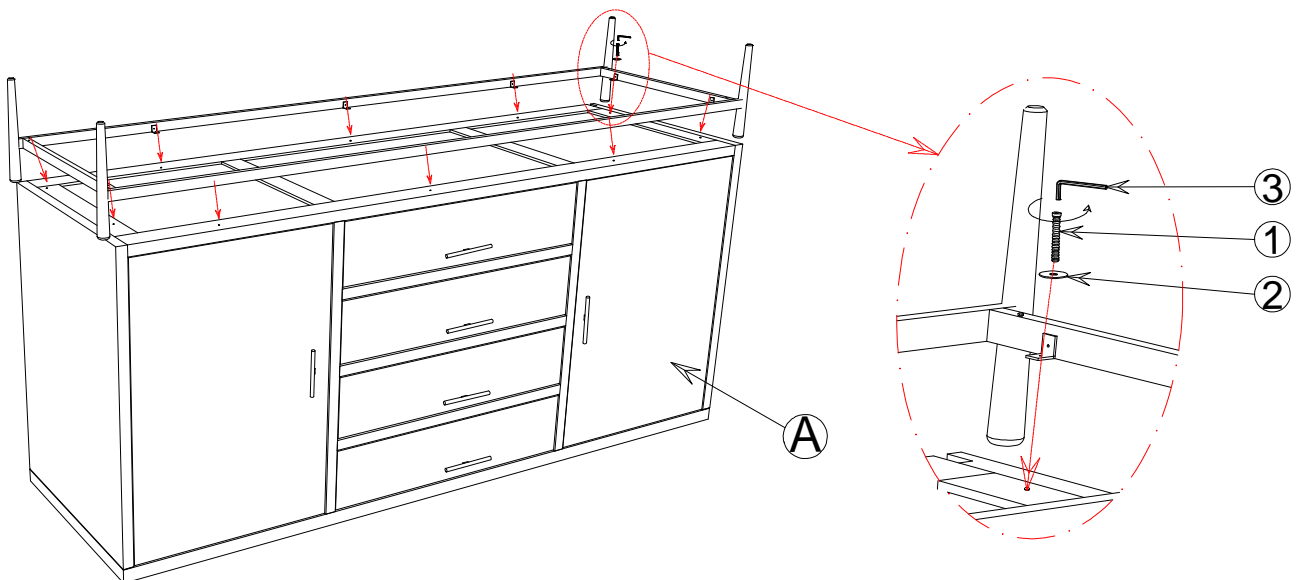
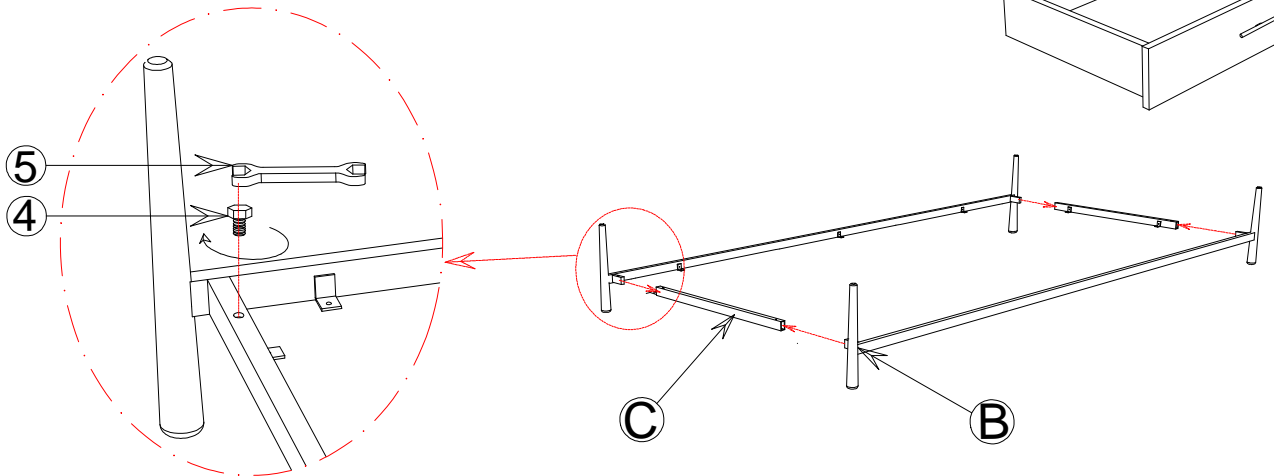
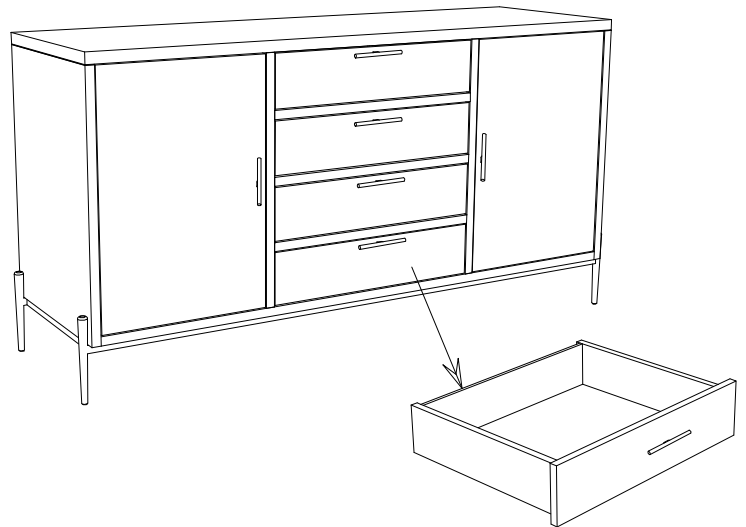

TO ASSEMBLY :

STEP 1 : Unpack buffet and remove drawers.

STEP 2 : Roll buffet on its back, then its top on a clean, soft surface.

STEP 3 : So doors do not swing open and get damaged.

STEP 4 : Thread the JCB bolt(4) to iron leg(B) & iron cross bar(C). tighten end assemblies fully.

STEP 5 : Set base assembly on the upside down case and attach with bolt (1) and washer (2) using allen wrench (3).

STEP 6 : Tighten bolts in step 6 fully with allen wrench (3) & wrench (5) then carefully turn the buffet upright.

STEP 7 : Install drawers.