



63__TP3__

Write purchase model number here for future reference

212191

212191

212191

212191

212191

212191

212191

212191

- 061307A**
Spray Outlet (3/pkg, 1 key)
0.35 GPM (1.3 L/min)
- 061266A**
Laminar Outlet (3/pkg, 1 key)
0.5 GPM (1.9 L/min)
- 061268A**
Laminar Outlet (3/pkg, 1 key)
1.5 GPM (5.7 L/min)
- 063246A / 063246SS**
Proximity Ara
Spout Assembly
0.35 GPM (1.3 L/min)
- 063247A / 063247SS**
Proximity Ara
Spout Assembly
0.5 GPM (1.9 L/min)
- 063248A / 063248SS**
Proximity Ara
Spout Assembly
1.5 GPM (5.7 L/min)

INSTALLATION AND SET-UP INSTRUCTIONS		
Model Number	Description	Page #
631TP3x0	Battery Operated Surface Mount Box #0	2
631TP3x1TR	Battery Operated Control Box #1 Trim	4
631TP3x8TR	Battery Operated Control Box #8 Trim	6
630TP3x0	Hard Wire Operated Surface Mount Box #0	8
630TP3x1TR	Hard Wire Operated Control Box #1 Trim	10
630TP3x8TR	Hard Wire Operated Control Box #8 Trim	12

NOTES:

For optimum performance of this product, the recommended system pressure is between 20 and 80 PSI static. This product will operate up to a maximum of 125 PSI static per ANSI and CSA requirements. However, it is not recommended the pressure go above 80 PSI. Thermal expansion or leaking pressure reducing valves may require the use of expansion tanks or relief valves to ensure your system never exceeds its maximum intended pressure setting.

Control Box #0 and #1
Designed for routine 180°F (82°C) disinfection cycles up to 10 minutes.

Control Box #8
High temperature disinfection cycles not recommended for #8 control box as the thermostatic mixing valve limits the higher temperature water flow output.

- Use 3-conductor 18AWG wire between transformer and hardwire converter / driver board earth ground.
- Use Delta Commercial approved transformers and mount the transformer a minimum of 6" (152 mm) away from the Delta driver board enclosure.
- Refer to **Proximity Application Notes** on SpecSelect for installation best practices, proper grounding and wiring diagrams.

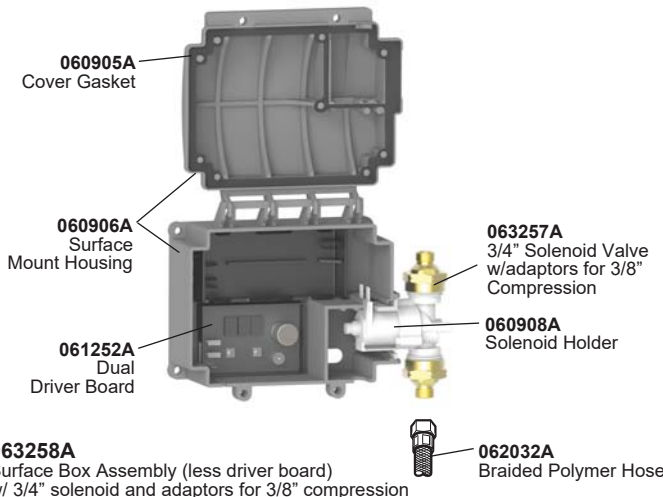
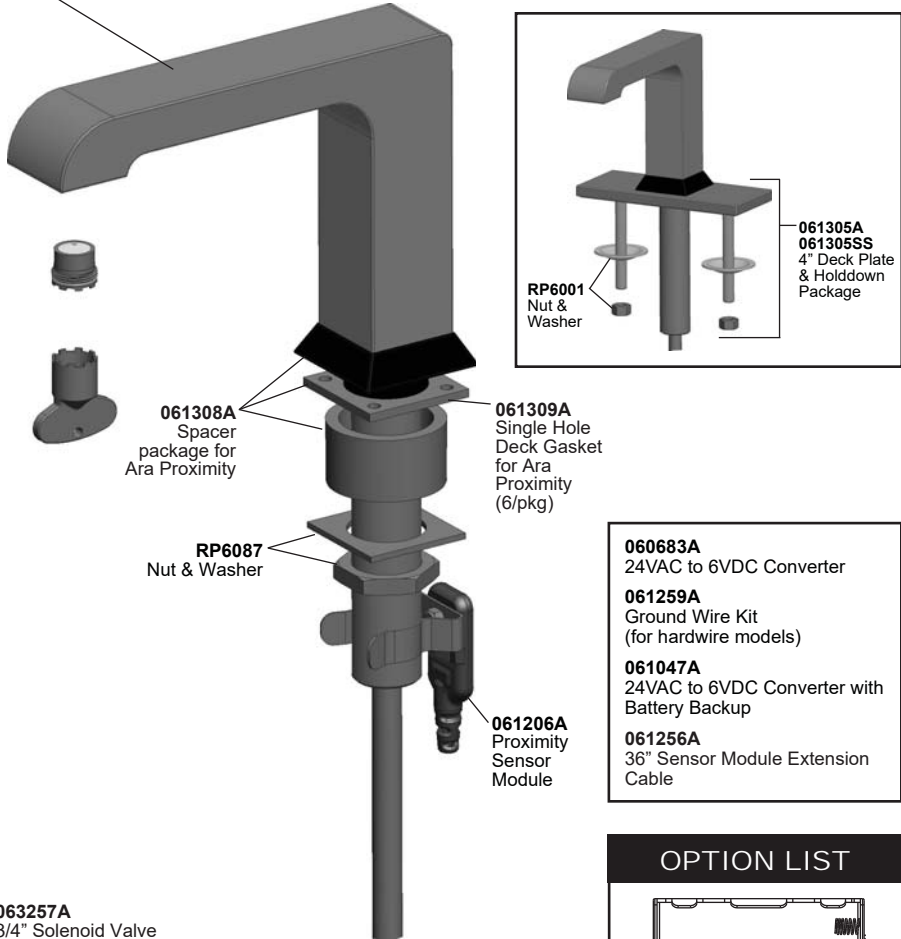

- 060683A**
24VAC to 6VDC Converter
- 061259A**
Ground Wire Kit
(for hardwire models)
- 061047A**
24VAC to 6VDC Converter with
Battery Backup
- 061256A**
36" Sensor Module Extension
Cable

OPTION LIST

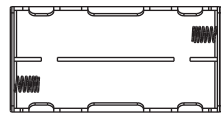
- 
060681A
Battery Holder
- TRANSFORMERS**
- 060704A**
Transformer 110 to 24 VAC 20VA
up to 5 Electronic Valves
- 060771A**
Transformer 110 to 24 VAC 40VA
up to 10 Electronic Valves
- DECK PLATE**
- 061305A / 061305SS**
4" Deck Plate & Hold-Down Pkg

COVER	
060577A 12" Stainless Steel Cover	060073A Screws (4/pkg) and driver bit for covers

TMV Repair Kits	
061137A Adjustment Wrench	063164A Check Valves (2/pkg)

PLEASE LEAVE this M&I Sheet with the owner, maintenance plumber, etc. as items relating to ongoing maintenance suggestions and procedures are included.