

SECTION A-A

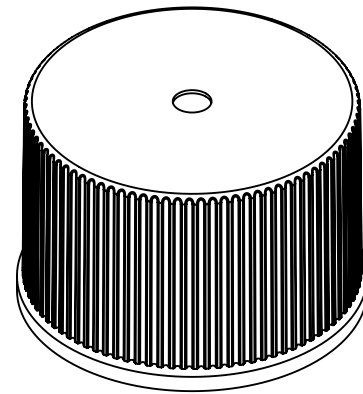

STATIC TORQUE RECOMMENDATION: 8-12in-lbs
 REQUIREMENT MAY VARY DEPENDING UPON CONTAINER MATERIAL,
 NECK FINISH, AND CAPPING EQUIPMENT

REFERENCE	DIMENSION	TOLERANCE	UNITS
E	0.720 [18.29]	±0.007 [0.18]	in [mm]
T	0.803 [20.40]	±0.007 [0.18]	in [mm]
H	0.540 [13.72]	±0.006 [0.15]	in [mm]
OAH	0.595 [15.11]	±0.007 [0.18]	in [mm]
OD	0.902 [22.91]	±0.008 [0.20]	in [mm]
PART WEIGHT	1.30	±0.20	g

THREAD DETAIL INFORMATION: # THREADS PER INCH 0.000" [X.XX] PITCH 000° FULL DEPTH THREADS

DISCLAIMER

THIS INFORMATION IS PROVIDED AS A GENERAL GUIDE, INCLUDING DIMENSIONS. IT IS THE CUSTOMER'S RESPONSIBILITY TO SELECT THE PROPER CONTAINER FOR PRODUCT AND APPLICATION COMPATIBILITY.

DISTRIBUTED BY:



REF NO.:

DWG31814

DESCRIPTION:

20-400 PP Matte Top, Ribbed Sides Cap with F217 Liner

- This data sheet describes F-217® products
- This product is a three-ply co-extruded liner consisting of a foamed Low Density Polyethylene (LDPE) core sandwiched between two layers of solid Low Density Polyethylene

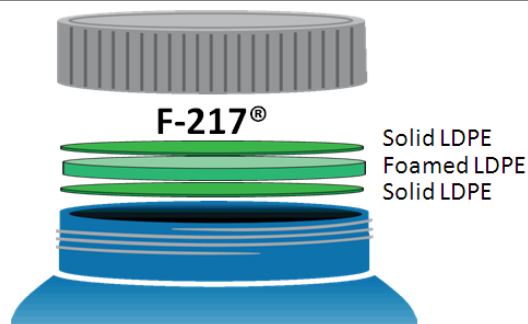

MRP Description - (024)F217.035 PL

Typical Product Attributes

Construction

Structure	Solid LDPE / Foamed LDPE / Solid LDPE	Solid LDPE / Foamed LDPE / Solid LDPE
Color	White or as Specified	White or as Specified
Density		
for 20 ~ 30 mil (0,51 ~ 0,76 mm)	0,48 ± 0,03 g / cm ³	30 ± 2 lbs / ft ³
for 35 ~ 125 mil (0,89 ~ 3,18 mm)	0,40 ± 0,03 g / cm ³	25 ± 2 lbs / ft ³
Thickness Tolerance		
for 20 ~ 60 mil (0,51 ~ 1,52 mm)	± 0,127 mm	± 5 mil
for 65 ~ 90 mil (1,65 ~ 2,29 mm)	± 0,178 mm	± 7 mil
for 95 ~ 125 mil (2,41 ~ 3,18 mm)	± 0,254 mm	± 10 mil
Available Width		
for 20 ~ 60 mil (0,51 ~ 1,52 mm)	22,2 ~ 1016,0 mm	7/8 ~ 40 inch
for 65 ~ 125 mil (1,65 ~ 3,18 mm)	25,4 ~ 228,6 mm	1 ~ 9 inch
Width tolerance	± 1,6 mm	± 1/16 inch

Regulatory Compliance

FDA Compliance	21 CFR 177.1520 (Olefin Polymers) 21 CFR 177.1210 (Closures with Sealing Gaskets for Food Containers) 21 CFR 175.300 (Resinous and Polymeric Coatings)
Drug Master File (DMF)	2434
Other Compliances	USFDA Food Allergen Guidelines; California Proposition 65 Labeling Requirements; Limitations of Heavy Metals in Packaging per CONEG & EU 94/62/EC, Article 11

DISTRIBUTED BY:



REF NO.:

DWG31814

DESCRIPTION:

20-400 PP Matte Top, Ribbed Sides Cap with F217 Liner

DISCLAIMER

THIS INFORMATION IS PROVIDED AS A GENERAL GUIDE, INCLUDING DIMENSIONS. IT IS THE CUSTOMER'S RESPONSIBILITY TO SELECT THE PROPER CONTAINER FOR PRODUCT AND APPLICATION COMPATIBILITY.